



Volume 120

2023

p-ISSN: 0209-3324

e-ISSN: 2450-1549

DOI: <https://doi.org/10.20858/sjsutst.2023.120.12>

Journal homepage: <http://sjsutst.polsl.pl>



Article citation information:

Muradian, L., Shvets, A., Shvets, A. Some dynamic processes at longitudinally-transverse shift of the cargo. *Scientific Journal of Silesian University of Technology. Series Transport*. 2023, **120**, 187-204. ISSN: 0209-3324. DOI: <https://doi.org/10.20858/sjsutst.2023.120.12>.

Leontii MURADIAN¹, Anzhelika SHVETS², Angela SHVETS³

SOME DYNAMIC PROCESSES AT LONGITUDINALLY-TRANSVERSE SHIFT OF THE CARGO

Summary. The purpose of the work is to study the influence of the longitudinally-transverse shift of the cargo's center of mass on the dynamic loading of the wagon in order to solve the problem of predicting the dynamics and stability of an asymmetrically loaded railroad vehicle. During the analytical simulation, a multibody model of the spatial oscillations of the wagon was used. The differential equations of wagon oscillations are compiled using the d'Alembert principle, while the wagon is considered as a system with 42 degrees of freedom. The work presents the results of analytical simulation of some dynamic processes of interaction of railroad vehicles with the rails on the example of flat wagons. The results of the analytical simulation are presented, taking into account the speed of movement along the curved sections of the railway track. The proposed multibody model "heavy cargo – wagon" makes it possible to analytically determine the dynamic characteristics of the system and ensure the development of such methods of transportation of heavy cargo that meet the requirements of train traffic safety. The application of the obtained results will help improve the running safety of freight wagons and enhance the technical and economic performance of railways.

Keywords: heavy cargo, flat wagon, shifting cargo, speed of movement

¹ Faculty of Transport Engineering, Ukrainian State University of Science and Technologies, Lazaryana St., 2, 49010 Dnipro, Ukraine. Email: leontymuradian@gmail.com. ORCID: <https://orcid.org/0000-0003-1781-4580>

² Faculty of Transport Engineering, Ukrainian State University of Science and Technologies, Lazaryana St., 2, 49010 Dnipro, Ukraine. Email: angtiger.am@gmail.com. ORCID: <https://orcid.org/0000-0002-0717-2521>

³ EDSO MBCSS, Ukrainian State University of Science and Technologies, Lazaryana St., 2, 49010 Dnipro, Ukraine. Email: angela_shvets@ua.fm. ORCID: <https://orcid.org/0000-0002-8469-3902>

1. INTRODUCTION

Rail transportation is one of the cheapest, most reliable, and safest ways to transport goods. The running safety of freight trains, the values of acceptable speeds and carrying capacity, the costs of maintaining the railroad vehicle and track facilities, and the increase in the overhaul runs of wagons significantly depends on the design of railway freight wagons [15, 19, 23]. Modernity puts forward new requirements for increasing the level of forces of dynamic interaction between the railroad vehicle and the track, in turn, the technical level of the railroad vehicle of railway transport has a direct impact on the economic performance of the transport industry and the country's economy as a whole [16, 18].

It should not be forgotten that the occurrence of larger forces affects the acceleration of the wearing process, the consequence of which may be sudden damage to the element. Therefore, it is important to monitor the wear of elements, including using non-invasive methods such as vibroacoustic diagnostics [4-6, 10-12].

The technical re-equipment of railway transport is a rather complicated, expensive, but necessary task. In the current crisis period, it is important solution of problems related to more intensive use of the existing railroad vehicle. These problems include resource-saving and safe methods of transporting goods on open railroad vehicle [24].

When choosing the type of railroad vehicle for the transportation of a particular cargo, as a rule, one has to solve a rather important problem: create specialized or use universal wagons. There is no single answer. Only a technical and economic calculation of a specific method of transporting goods using one or another type of universal or specialized railroad vehicle allows us to answer this question [22, 26].

Transportation of metal products by railway is an expensive and sometimes dangerous activity, as well as one of the most important areas of rail transportation. Metal is one of the most common industrial goods, and its transportation by railway transport requires special rules. The advantage of transporting rolled metal products by railways is the low cost, especially over long distances [21, 25].

For railway transportation of metal, universal (flat wagons, gondola cars, covered wagons) and specialized railcars are used. The specialized wagons allow achieving high standards of transportation of different types of cargo. Transportation of large diameter pipes is carried out on universal flat wagons. However, there is a need for additional props for mounting, which is described in the technical conditions.

When using universal wagons only for the transportation of pipe billets, safety shields, racks and attachments after the initial installation can be used repeatedly, which speeds up the processing of wagons, both during loading and unloading, and also makes it more expedient to use the length and carrying capacity of the specified railroad vehicle.

The safety of train traffic and the storage of transported goods also directly depend on the method of placement and securing of goods. For the stability and safety of transportation, special attention is paid to the center of mass, which should be at the intersection of the central longitudinal and transverse lines of symmetry. If you need to transport non-standard cargo, a slight shift in the center of mass is possible. In addition, in the process of transporting goods, sometimes it becomes necessary to arrange them asymmetrically in the wagon. The shift of the cargo's center of mass relative to the central planes of symmetry of the wagon is also possible during transportation [21, 22, 25].

In accordance with the rules for the carriage of goods in open-type wagons, when placing cargo on two mainstays laid symmetrically across the frame of the flat wagon with respect to

the transverse symmetry plane of the flat wagon, depending on the load on the mainstay is determined the location of the mainstays and the width B_ℓ .

If mainstays are located within the base of the flat wagon (Fig. 1), the minimum allowable distance ℓ_g is determined according to Tab. 1.

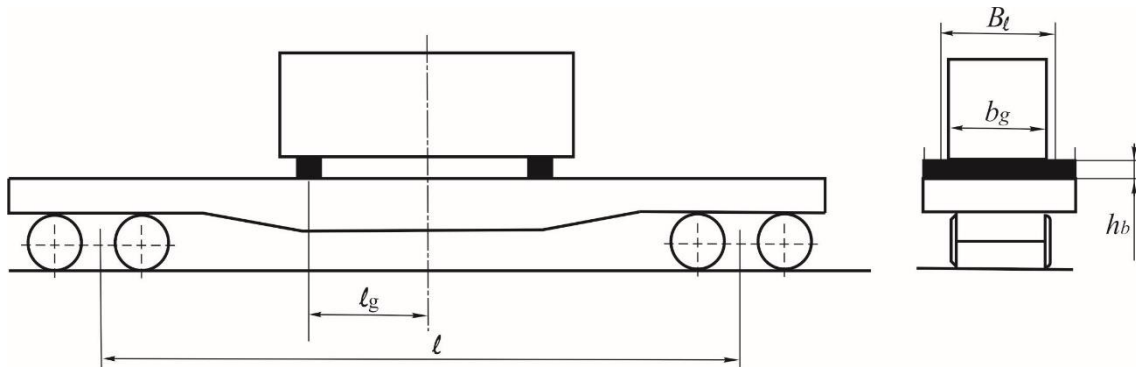

Fig. 1. Placement of mainstays within the base of the flat wagon

Tab. 1

The disposition of the mainstays located within the base of the flat wagon

Load on one mainstay [tf]	Minimum permissible distance ℓ_g [mm] at width B_ℓ [mm] of load distribution		
	880	1 780	2 700
<20	550	325	0
22	950	750	500
25	1 200	1 100	900
27	1 425	1 350	1 200
30	1 675	1 600	1 450
33	2 075	1 885	1 850
36	3 100	2 900	2 400

If the mainstays are located outside the flat wagon base (Fig. 2), the maximum permissible distance ℓ_g is determined in accordance with Tab. 2.

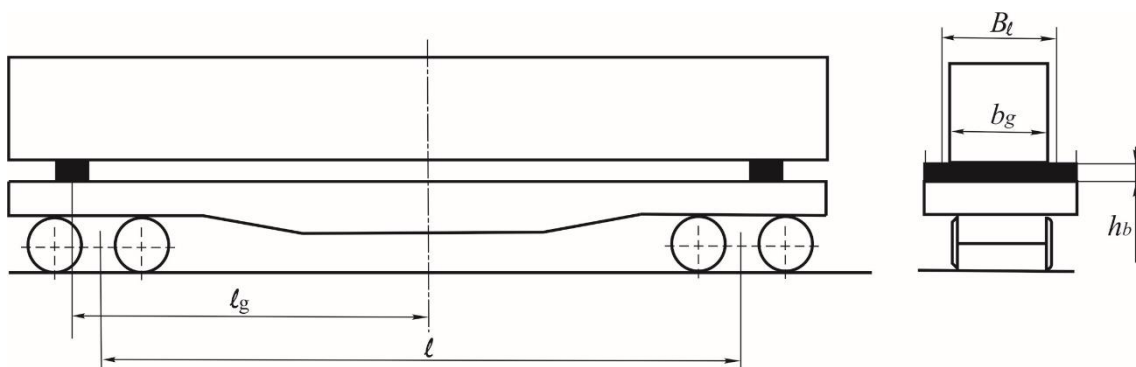

Fig. 2. Placement of mainstays within the base of the flat wagon

Tab. 2

The disposition of the mainstays located outside the base of the flat wagon

Load on one mainstay [tf]	Maximum permissible distance ℓ_g [mm] at width B_ℓ [mm] of load distribution		
	880	1 780	2 700
<12,5	6 250	6 350	6 400
15,0	6 000	6 050	6 150
20,0	5 600	5 650	5 750
25,0	5 400	5 450	5 550
30,0	5 370	5 420	5 520
33,0	5 350	5 400	5 500
36,0	5 330	5 380	5 500

A significant part of the cargo transported on the flat wagons is also heavy equipment with an asymmetrically located center of mass or one-sided lateral oversize, which requires limiting the speed of trains or stopping oncoming traffic on double-track sections. This causes a decrease in the throughput and carrying capacity of the railway and a delivery time extension.

Heavy cargos often have their own elastic-dissipative or elastic fastening elements to the flat wagon frame, which can affect the nature of the vibrations of the flat wagon and cargo, and the resulting dynamic forces. Therefore, the further enhancement of transportation qualities and the development of scientifically reasonable permissible shifts of the cargo's center of mass from the axes of symmetry of the flat wagon are of particular importance. When developing them, special attention should be paid to the problem of traffic safety, since intense oscillations of the flat wagon and large dynamic forces can occur. In this case, it is necessary to develop a general analytical method for researching flat wagon oscillations with the asymmetric placement of heavy cargos of different masses, both with elastic-dissipative elements between the cargo and the flat wagon frame and without them [8].

The article [22] presents the results of the analytical simulation of the dynamic characteristics of a railway vehicle in the example of flat wagons. On the basis of the study, it was obtained: longitudinal displacements of the cargo do not cause an increase in the indicators of vertical and horizontal dynamics, as well as the coefficient of stability from wheel derailment, the limitation of transverse shift, is not caused by an increase in indicators of dynamics, but a sharp decrease in the derailment stability indicator.

The study [21] is devoted to determining the influence of the features of the asymmetric loading of the flat wagon on the value of the wear indicator of a wheel-rail pair when changing parameters that occur during operation. In the analysis of the results obtained, it was noted that the lozengeing of the side frames of the flat wagon bogie in the speed range of 50-80 km/h does not affect the wear factor of wheels and rails, both with longitudinal and transverse shift of the cargo's center of mass. Longitudinal displacements of cargo on flat wagons do not cause an increase in the researched indicators.

The purpose of the theoretical study of the dynamic interaction of the body of a flat wagon and the running gears of the standard model is to study the stability of movement with a longitudinally-transverse shift of the cargo's center of mass and a simultaneous increase in the speed of movement.

2. METHODOLOGY

Analytical simulation for dynamic loading studies of a wagon (coupling of wagons) in operation is reflected in many works [2, 3, 7, 20]. The mathematical models implemented in this case give solutions that are in good agreement with the experimental data [9, 20].

When modeling the spatial oscillations of wagons, the following assumptions were introduced. It is assumed that the flat wagon has a single-stage spring suspension and consists of 12 solid bodies: a heavy cargo, a body, 2 bolsters, 4 side frames and 4 wheelsets (Fig. 3).

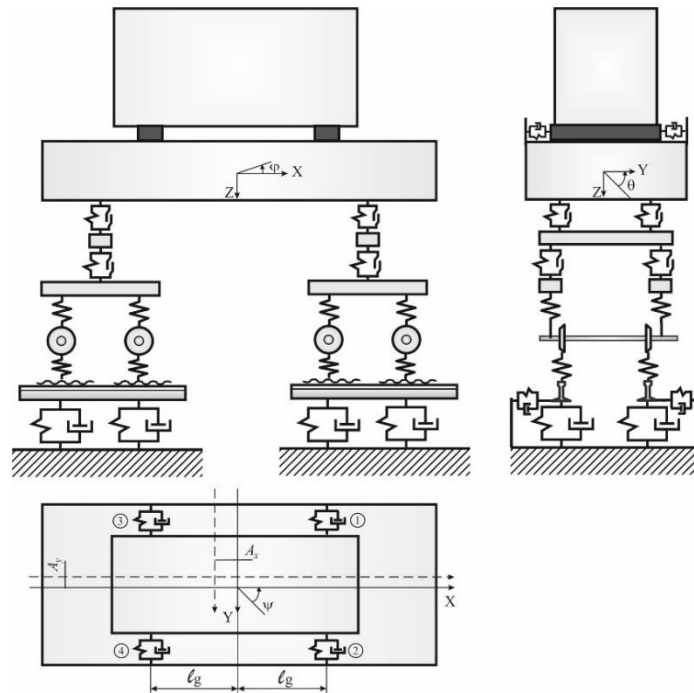

Fig. 3. Schematic view of a four-axle flat wagon with a load

The scheme of the bogie frame is supposed to be articulated. The properties of the track base in both planes are taken into account as elastic-viscous and inertial. The designations of the bodies of the system are given in Tab. 3.

Tab. 3

Elements of the flat wagon and their displacements

Systems bodies	Displacement along the axes					
	Linear			Angle		
	X	Y	Z	X	Y	Z
heavy cargo	x_g	y_g	-	-	-	ψ_g
flat wagon body	x	y	z	θ	φ	ψ
bolsters	x_i	y_i	z_i	θ_i	φ_i	ψ_i
side frames	x_{fij}	y_{fij}	z_{fij}	θ_{fij}	φ_{fij}	ψ_{fij}
wheelsets	x_{kim}	y_{kim}	z_{kim}	θ_{kim}	φ_{kim}	ψ_{kim}
wheels	x_{imj}	y_{imj}	z_{imj}	-	-	-
rails	-	y_{pinj}	z_{pinj}	-	-	-

In Tab. 3, the following index values are given: $i=1, 2$ is a number of a bogie, $j=1$ is the left side of a wagon, $j=2$ is the right side of a wagon, $m=1, 2$ is a number of a wheelset in the bogie [1]. All values for parameters and symbols used are given in the Notations.

The center of mass of the flat wagon body is placed at the origin of the coordinate system, and the center of mass of the cargo is shifted by the values A_x and A_y (Fig. 3).

It is assumed that the following displacements are possible between the wagon bodies:

- heavy cargo – body: lateral displacement y_g and yawing (hunting) ψ_g are possible;
- body – bolster: there are no relative displacements, except for the yawing of the bolster ψ_i , which coincides with the yawing of the wheelsets of the bogies ψ_{ki} ;
- bolster – side frame: relative translational (Δ_{cyi} along the Y and Z axes – Δ_{czi}) and angular $\Delta_{c\psi i}$ (when yawing) displacements of these bodies are possible;
- side frame – wheel set: in this compound, there are also possible relative translational (Δ_{fyimj} along the Y and Z axes – Δ_{fzimj}) and angular $\Delta_{f\psi imj}$ (when yawing) displacements of these bodies.

The constraint equations are written as follows [1]:

- based on the above assumptions about the relative displacements of the body and bolsters, the constraint equations correspond to:

$$x_i = x + h_w \cdot \varphi \quad (1)$$

$$y_i = y - (-1)^i \cdot \ell \cdot \psi - h_w \cdot \theta \quad (2)$$

$$z_i = z + (-1)^i \cdot \ell \cdot \varphi \quad (3)$$

$$\varphi_i = \varphi \quad (4)$$

$$\theta_i = \theta \quad (5)$$

- longitudinal gaps between bolsters and side frames are neglected, therefore:

$$x_{fij} = x_i - (-1)^j \cdot b \cdot \psi_{kij} = x_i - (-1)^j \cdot b \cdot \psi_{ki} \quad (6)$$

- lateral motion and yawing of the side frames of one bogie coincide with each other:

$$y_{fi1} = y_{fi2}, \quad \psi_{fi1} = \psi_{fi2} \quad (7)$$

- there is no lateral rolling of the side frames $\theta_{fij} = 0$,
- the translational displacement of the heavy cargo and wheelsets coincides with the translational displacement of the body $x_{kij} = x_g = x$;
- the angles of rotation of the wheelsets relative to the horizontal transverse axis Y will be determined without taking into account the creepage of the wheels:

$$\varphi_{kim} = \frac{x_{kim}}{r} \quad (8)$$

- the yawing of the wheelsets coincides with the yawing of the corresponding bolster:

$$\psi_{ki1} = \psi_{ki2} = \psi_i \quad (9)$$

- compound between vertical movements of wheels and rails, assuming that all wheels move without separation from the rails:

$$z_{pimj} = z_{imj} + \Delta r_{imj} - \eta_{vimj} = z_{kim} + (-1)^j \cdot b_2 \cdot \theta_{kim} + \Delta r_{imj} - \eta_{vimj} \quad (10)$$

The system has $12 \cdot 6 + 8 \cdot 2 - 46 = 42$ degrees of freedom, and the following values are accepted as generalized coordinates: $z, \varphi, \theta, y, y_g, \psi, \psi_g, \psi_{fi}, y_{fi}, z_{fij}, \varphi_{fij}, \psi_{ki}, y_{kim}, z_{kim}, \theta_{kim}, y_{pimj}, x$.

To compile differential equations for oscillations of a loaded wagon, expressions are used for the relative displacements of all bodies of the system:

- heavy cargo – wagon body:

$$\Delta_{g1} = \Delta_{g2} = y_g + \ell_g \cdot \psi_g - y - (\ell_g + A_x) \cdot \psi_g \quad (11)$$

$$\Delta_{g3} = \Delta_{g4} = y_g - \ell_g \cdot \psi_g - y + (\ell_g - A_x) \cdot \psi_g \quad (12)$$

- wagon body – bolster when yawing:

$$\Delta_{\psi i} = \psi - \psi_{ki} \quad (13)$$

- bolster – side frame in vertical, horizontal transverse directions and when yawing:

$$\Delta_{cyi} = y - (-1)^i \cdot \ell \cdot \psi - h_w \cdot \theta - y_{fi} \quad (14)$$

$$\Delta_{czi} = z + (-1)^i \cdot \ell \cdot \varphi + (-1)^j \cdot b \cdot \theta - z_{fij} \quad (15)$$

$$\Delta_{c\psi i} = \psi_i - \psi_{fi} \quad (16)$$

- side frame – wheel set in vertical, horizontal transverse directions and when yawing:

$$\Delta_{fyimj} = y_{fi} - y_{kim} - (-1)^m \cdot \ell_1 \cdot \psi_{fi} \quad (17)$$

$$\Delta_{fzimj} = z_{fij} - z_{kim} + (-1)^m \cdot \ell_1 \cdot \varphi_{fij} - (-1)^j \cdot b_1 \cdot \theta_{kim} \quad (18)$$

$$\Delta_{f\psi imj} = \psi_{fi} - \psi_{ki} \quad (19)$$

- wheelset – rail in vertical Eq. (10), transverse and longitudinal directions:

$$x_{ij} = x - (-1)^j \cdot b_2 \cdot \psi_{ki} \quad (20)$$

$$y_{imj} = y_{ki} - r_{imj} \cdot \theta_{kim} - y_{pimj} - \eta_{himj} \quad (21)$$

Wheels creepage on rails in this case take the form [1]:

$$\mathcal{E}_{ximj} = - \left[(-1)^j \cdot b_2 \cdot \frac{\dot{\psi}_{kim}}{v} + \frac{\Delta r_{imj}}{r} \right] \quad (22)$$

$$\mathcal{E}_{yimj} = \frac{1}{v} \left[\dot{y}_{fi} - (-1)^m \psi_{fi} \right] - \psi_{ki} \quad (23)$$

Where $\Delta r_{imj} = f(y_{imj})$ are wheel rolling circle radius changes:

$$\Delta r_{imj} = (-1)^j \mu_0 y_{imj} + \alpha_1 \left[(-1)^j y_{imj} - \delta \right]^3 \sigma_0 \left[(-1)^j y_{imj} - \delta \right] \quad (24)$$

Parameter r_{imj} will allow exploring different levels of wear of bogies' wheelsets. With horizontal transverse movements of the wheels relative to the rails, the radii of the rolling circles of the wheels Δr_{imj} and the tangents of the angles $\tan \alpha_{imj}$ of inclination of the rolling surface of the wheels to the horizontal change, which depend on the displacements y_{imj} . They can be determined approximately by analytical expressions or set based on calculations of the real profile of the wheel tread surface and the profile of the rail head [1, 20]:

$$\tan \alpha_{imj} = \frac{d}{dy_{imj}} (\Delta r_{imj}) = (-1)^j \mu_0 + 3\alpha_1 \left[(-1)^j y_{imj} - \delta \right]^2 \sigma_0 \left[(-1)^j y_{imj} - \delta \right] \quad (25)$$

Friction forces arise between the wheels and rails, the components of which along the X and Y axes are determined according to the Carter theory [2, 3, 13, 14]:

$$T_{ximj} = -F_{ximj} \cdot \mathcal{E}_{ximj}, \quad T_{yimj} = -F_{yimj} \cdot \mathcal{E}_{yimj} \quad (26)$$

The coefficients of pseudosliding are determined from the expression [1, 20]:

$$F_{ximj} = F_{yimj} = \frac{f_{imj}}{\sqrt{1 + h_{imj}^2 \cdot \mathcal{E}_{imj}^2}}; \quad h_{imj} = \frac{f_{imj}}{P_{imj} \cdot f_{fr}} \quad (27)$$

The coefficient f_{imj} depends on the total wheel pressure on the rail P_{imj} . The total relative slippage of the wheel on the rails is:

$$\mathcal{E}_{imj}^2 = \mathcal{E}_{ximj}^2 + \mathcal{E}_{yimj}^2 \quad (28)$$

The coefficient f_{imj} , depending on the total wheel pressure on rail P_{imj} , is determined as in [1, 2, 20]:

$$f_{imj} = 235 \cdot P_{imj} - 2.4 \cdot P_{imj}^2 + 0.01 \cdot P_{imj}^3 \quad (29)$$

$$P_{imj} = P_{st} \cdot \left(0.5 \pm \frac{A_x}{2\ell} \pm \frac{A_y}{2b_2} \right) + S_{pzimj} \quad (30)$$

In the Eq. (30) the interaction forces S_{pzimj} are equal to:

$$S_{pzimj} = a_{pz} \cdot \ddot{z}_{pimj} + \chi \cdot k_z \cdot \dot{z}_{pimj} + k_z \cdot z_{pimj} \quad (31)$$

$$S_{pyimj} = a_{py} \cdot \ddot{y}_{pimj} + \chi \cdot k_y \cdot \dot{y}_{pimj} + k_y \cdot y_{pimj} \quad (32)$$

Differential equations of wagon oscillations, compiled using the d'Alembert principle:

$$\left(m + m_g + 2m_{bl} + 4m_f + 4m_k + 4 \frac{I_{xk}}{r^2} \right) \cdot \ddot{x} + 2m_{bl} h_w \cdot \ddot{\varphi} - \sum_{i=1}^2 \sum_{m=1}^2 \sum_{j=1}^2 T_{ximj} = 0 \quad (33)$$

$$(m + 2m_{bl}) \cdot \ddot{y} + \sum_{i=1}^2 \sum_{j=1}^2 S_{cyij} - \sum_{n=1}^4 S_{gn} = 0 \quad (34)$$

$$(m + 2m_{bl}) \cdot \ddot{z} + \sum_{i=1}^2 \sum_{j=1}^2 S_{czij} - (m + 2m_{bl}) \cdot g = 0 \quad (35)$$

$$(I_x + 2m_{bl} \cdot h_w^2 + 2I_{xbl}) \cdot \ddot{\theta} - h_w \cdot \sum_{i=1}^2 \sum_{j=1}^2 S_{cyij} + b \cdot \sum_{i=1}^2 \sum_{j=1}^2 (-1)^j \cdot S_{czij} = 0 \quad (36)$$

$$(I_y + 2m_{bl} \cdot \ell^2 + 2m_{bl} \cdot h_w^2 + 2I_{ybl}) \cdot \ddot{\varphi} + 2m_{bl} \cdot h_w \cdot \ddot{x} + \ell \cdot \sum_{i=1}^2 \sum_{j=1}^2 (-1)^i \cdot S_{czij} = 0 \quad (37)$$

$$m_g \cdot \ddot{y}_g + \sum_{n=1}^4 S_{gn} = 0 \quad (38)$$

$$I_{zg} \cdot \ddot{\psi}_g + \ell_g \left(\sum_{n=1}^2 S_{gn} - \sum_{n=3}^4 S_{gn} \right) = 0 \quad (39)$$

$$(I_z + 2m_{bl} \cdot \ell^2) \cdot \ddot{\psi} - (\ell_g + A_x) \sum_{n=1}^2 S_{gn} + (\ell_g - A_x) \sum_{n=3}^4 S_{gn} - \ell \cdot \sum_{i=1}^2 \sum_{j=1}^2 (-1)^i S_{cyij} + \sum_{i=1}^2 S_{\psi i} = 0 \quad (40)$$

$$2m_f \cdot \ddot{y}_{fi} - \sum_{j=1}^2 S_{cyij} + \sum_{m=1}^2 S_{fyimj} = 0 \quad (41)$$

$$2I_{zf} \cdot \ddot{\psi}_{fi} - \sum_{j=1}^2 S_{cyij} - \sum_{i=1}^2 S_{\psi i} - \ell_1 \cdot \sum_{m=1}^2 S_{fyimj} + \sum_{m=1}^2 \sum_{j=1}^2 S_{fyimj} = 0 \quad (42)$$

$$m_f \cdot \ddot{z}_{fij} - S_{czij} + \sum_{m=1}^2 S_{fzimj} - m_f \cdot g = 0 \quad (43)$$

$$I_{yf} \cdot \ddot{\phi}_{fij} + \ell_1 \cdot \sum_{m=1}^2 (-1)^m S_{fzimj} = 0 \quad (44)$$

$$2I_{zk} \cdot \ddot{\psi}_{ki} + \sum_{j=1}^2 S_{c\psi ij} - \sum_{m=1}^2 \sum_{j=1}^2 S_{f\psi imj} + b_2 \cdot \sum_{m=1}^2 \sum_{j=1}^2 (-1)^j \cdot T_{ximj} = 0 \quad (45)$$

$$m_k \cdot \ddot{z}_{kim} - \sum_{j=1}^2 S_{fzimj} + \sum_{j=1}^2 S_{pzimj} - m_k \cdot g = 0 \quad (46)$$

$$I_{xk} \cdot \ddot{\theta}_{kim} - b_1 \cdot \sum_{j=1}^2 (-1)^j \cdot S_{fzimj} + \sum_{j=1}^2 [(-1)^j b_2 - r_{imj} \cdot f'(y_{imj})] \cdot S_{pzimj} + \sum_{j=1}^2 r_{imj} \cdot T_{yimj} = 0 \quad (47)$$

$$m_k \cdot \ddot{y}_{kim} - \sum_{j=1}^2 (T_{yimj} + S_{fyimj}) + \sum_{j=1}^2 f'(y_{imj}) \cdot S_{pzimj} = 0 \quad (48)$$

$$m_p \cdot \ddot{y}_{pimj} + T_{yimj} + S_{pyimj} - f'(y_{imj}) \cdot S_{pzimj} = 0 \quad (49)$$

Transverse horizontal forces in elastic-dissipative elements between the cargo and the body of the flat wagon (linear elastic-viscous connection):

$$S_{gn} = k_{gn} \cdot \Delta_{gn} + \beta_{gn} \cdot \dot{\Delta}_{gn}, \quad (n = 1 \div 4) \quad (50)$$

The following forces act on the bolsters, corresponding to the relative displacements of the bolsters and side frames [1, 20]:

$$S_{csij} = k_{cs} \cdot \Delta_{csij} + \beta_{cs} \cdot \dot{\Delta}_{csij} + F_{cs} \cdot \text{sign} \dot{\Delta}_{csij}, \quad (s = y, z, \psi) \quad (51)$$

Here, displacements Δ_{csij} are determined by Eqs (14-16).

The forces that arise between the side frames and wheelsets are determined by the following expressions:

$$S_{fsimj} = k_{fs} \cdot \Delta_{fsimj} + \beta_{fs} \cdot \dot{\Delta}_{fsimj} + F_{fs} \cdot \text{sign} \dot{\Delta}_{fsimj}, \quad (s = y, z, \psi) \quad (52)$$

Displacements Δ_{fsimj} are determined by Eqs (15-18).

When the body rolls relative to the bolster, there are moments caused by forces in the side bearings acting on the body and the bolster $S_{\psi i}$ [1, 20]:

$$S_{\psi i} = S_{\psi} \cdot \text{sign} \Delta_{\psi i} \quad (53)$$

The Eqs (33–49) describe the wagon movement along a straight railway track section. When movement is along a curved section, the coordinates in a stationary system are [1, 17]:

$$q^a = q + q^e \quad (54)$$

The coordinate q^e and its derivatives are determined by a curve equation. They also depend on the parameters of the curve and the railway track traversed by the center of mass of the flat wagon.

Based on the mathematical model by Eqs (33-49), a package of applied programs has been developed. The system of differential equations is reduced to the Cauchy normal form. A combined method is used to integrate the motion equations of a freight wagon. The beginning of the solution (acceleration) was carried out using the Runge-Kutta method, and the continuation using the iterative Adams-Bashforth method [20, 22].

3. MODELLING RESULTS

The speed of movement of the railway railroad vehicle when following curves is limited by the lateral pressure of the wheels of railway vehicle on the rails, the magnitude of the transverse acceleration, the possibility of unloading the wheels and derailing them. In this regard, it is necessary to research the oscillations of rail vehicles when they move along curved sections of railway tracks.

The study was carried out during the movement of the flat wagon model 13-4012 with standard side bearings and the running gears of the standard model at speeds of movement in the interval of 50-90 km/h. The stationary mode of movement of freight wagons was studied in order to establish the influence of only the considered factor, namely, the longitudinally-transverse shift of the cargo's center of mass. It was assumed that the running gear of the wagon and the rails are in a normal technical condition.

The payload capacity of flat wagons is 60-75 tons. Analytical studies were carried out, taking into account the mass of a heavy cargo of 63 tons. The longitudinally-transverse shift of the cargo's center of mass is taken into account in accordance with the regulatory and technical requirements for the placement and securing of cargo on an open railroad vehicle.

Fig. 4 shows the results of modeling the processes of lateral motion (Fig. 2) and vertical movement of the body (Fig. 4b) of the wagon body. The value of jerking displacements is insignificant. Therefore, it is not considered.

From Fig. 4a it can be seen that in the entire range of speeds, the lateral motion of the wagon body occurs in the direction of shifting the center of mass. With a negative value of the shift (Fig. 3), the lateral motion of the wagon's body occurs to the incoming wheelset (outer rail), with a positive value – to the inner rail. The vertical movements of the body are negligible and increase with the increasing shift of the center of mass (Fig. 4b).

Fig. 5 shows the results of modeling the processes of yawing (Fig. 5a), galloping (pitch) (Fig. 5b) and rolling motion of the flat wagon body (Fig. 5c).

The results of analytical simulations demonstrate that when the wagon moves in a curve, the yawing of the body ψ (Fig. 5a) at speeds of 50-80 km/h has a positive value and is directed in the plane of the track along the direction of the curve (Fig. 3). At a speed of 90 km/h, the wagon's body yawing process gets unstable, and reaches significant values, and also has a negative value. That is, the body turns in the plane of the path against the direction of the

curve. Body galloping φ (Fig. 5b) is insignificant and cannot have a significant impact on the loss of stability of the wheelset.

Superelevation of the outer rail excites roll oscillations θ . The results of analytical simulation demonstrate that the rolling motion (Fig. 5c) of the flat wagon body is much more dependent on the shift of the center of mass. An analysis of the values of θ shows that in the entire range of movement speeds, when the center of mass is shifted towards the outer rail, the side roll oscillations occur towards the inner one and vice versa.

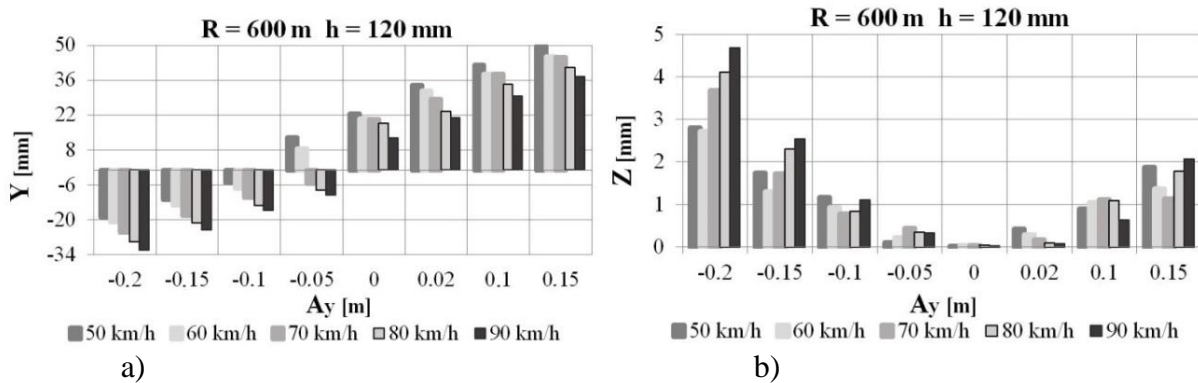

Fig. 4. Dependencies on the longitudinally-transverse shift of the cargo's center of mass: a – lateral motion of the wagon's body; b – vertical movement of the wagon's body

Let us analyze the yawing of the front ψ_{bg1} (Fig. 6a) and rear ψ_{bg2} (Fig. 6b) bogies in the direction of wagon movement.

The front and rear bogies are yawing in opposite directions, and ψ_{bg2} exceeds the similar values of ψ_{bg1} for the front bogie. The yawing of the wagon body coincides in direction with the yawing of the rear bogie ψ_{bg2} (Fig. 5a) except for the speed of 90 km/h. Body yawing oscillations occur in antiphase to the front bogie in the direction of movement.

The disadvantage of the base model of a running gear is the imperfection of mechanical connections, which worsens its driving performance and contributes to the occurrence of intense oscillations of yawing of wheelsets. Fig. 7 shows the results of modeling the processes of yawing of the first wheelset of the front bogie (Fig. 7a) and the directional force at the wheel-rail contact point (Fig. 7b).

The nature of the yawing of the front bogie (Fig. 6a) coincides with the yawing process of the first wheel set of the front bogie (Fig. 7a). The yawing angles have a negative value and are directed against the direction of the curve. The directional force at the wheel-rail contact point acting on the wheel from the side of the track (Fig. 5b), when the center of mass is shifted towards the inner rail, on average, decreases by 30-50%. The lateral motion of the body increases while the directional force at the wheel-rail contact point is reduced.

4. CONCLUSIONS

An analytical model of the dynamic interaction of a flat wagon with a heavy cargo is proposed, taking into account the longitudinally-transverse shift of the center of mass. The study contains the development of methods for analytical simulation of dynamic processes of interaction between railroad vehicle and rails. Similar analytical simulations can be applied when performing a quantitative and qualitative assessment of the effect of the mass center's

shift on the dynamic characteristics of the railroad vehicle when moving along track sections with irregularities.

Based on the results of the analytical simulations carried out on the dynamic processes of interaction between a flat wagon and a railway track structure, it is possible to conclude the following:

- in the entire range of speeds, the lateral motion of the wagon body with a heavy cargo weighing 63 tons occurs in the direction of shifting the center of mass;
- at a speed of 90 km/h, the wagon body yawing process gets unstable and reaches significant values. That is, the wagon body turns in the plane of the path against the direction of the curve;
- in the entire range of speeds, when the center of mass is shifted towards the outer rail thread, the rolling motion of the wagon body occurs towards the inner one, and vice versa;
- the directional force at the wheel-rail contact point, when the center of mass is shifted towards the inner rail, on average decreases, while the lateral motion of the body increases.

Significant amounts of lateral motion and yawing of the wagon body with heavy cargo when a longitudinally-transverse shift of the cargo's center of mass are mainly due to the fact that the load from the cargo is transferred to a greater extent to the front bogie, and the rear bogie is unloaded. This, combined with a reduction in directional force at the wheel-rail contact point, leads to a possible loss of wheel derailment stability.

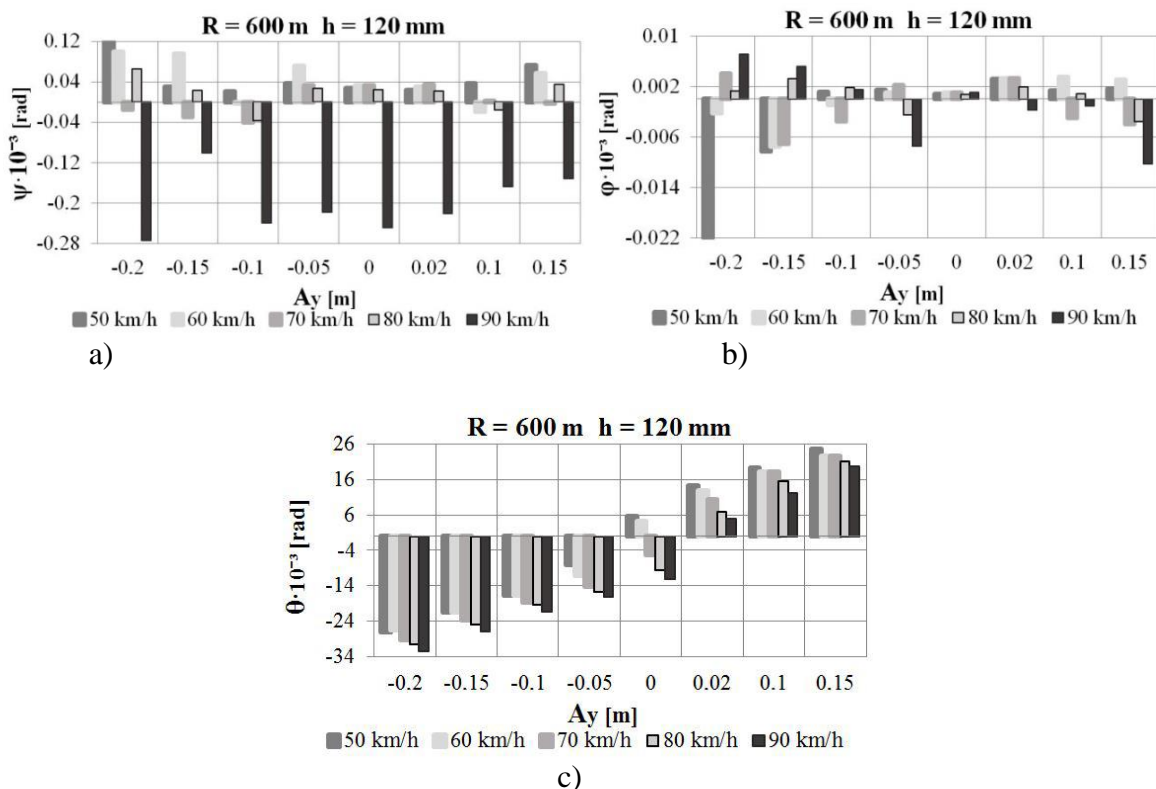

Fig. 5. Dependences on the longitudinally-transverse shift of the cargo's center of mass: a – yawing of the wagon body; b – galloping (pitch) of the wagon's body; c – rolling motion of the wagon's body

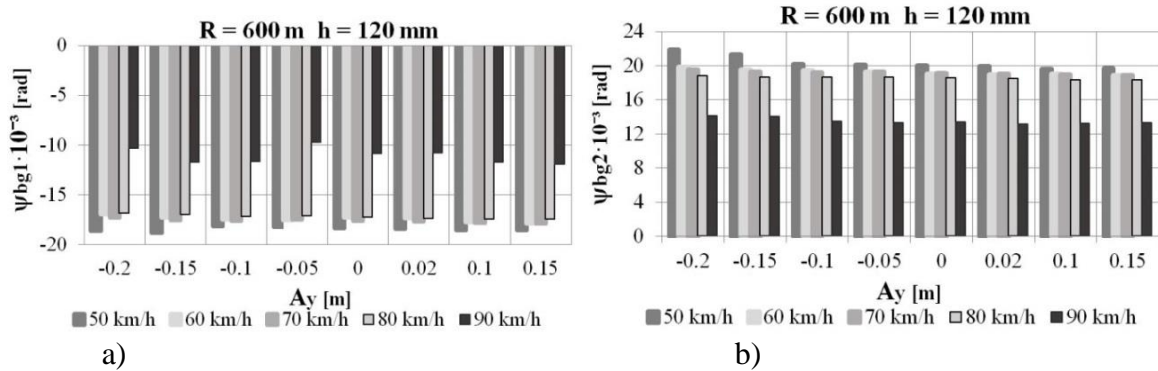

Fig. 6. Dependences on the longitudinally-transverse shift of the cargo's center of mass: a – yawing of the front bogie; b – yawing of the rear bogie

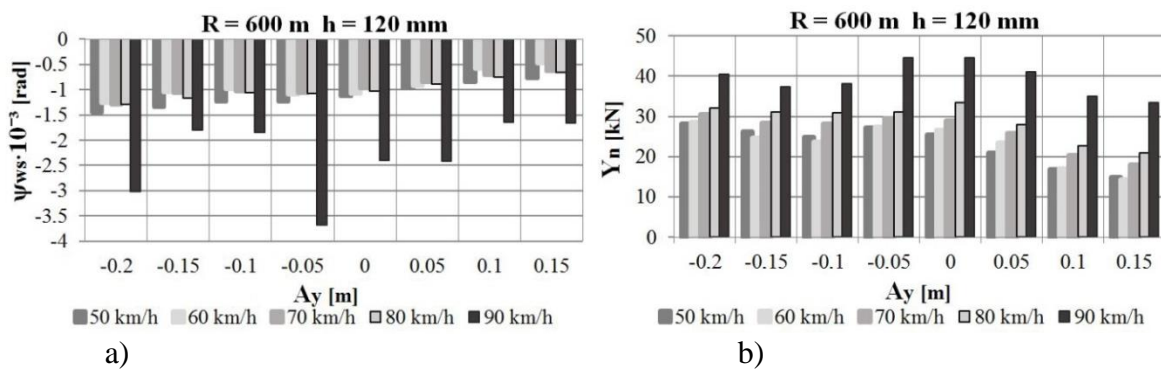

Fig. 7. Dependences on the longitudinally-transverse shift of the cargo's center of mass: a – yawing of the first wheelset of the front bogie; b – directional force at the wheel-rail contact point

References

1. Blokhin Evgen, Oleksandr Pshinko, Viktor Danovich, Mykhailo Korotenko. 1998. „Effect of the state of car running gears and railway track on wheel and rail wear”. In: *Railway Bogies and Running Gears: Proceedings of the 4th International Conference*: 313-323. Budapest, Hungary, 21-23 September 1998.
2. Blokhin Evgen, Viktor Danovich, Mykolay Morozov. 1986. *Mathematical model of spatial oscillations of a four-axle rail vehicle*. Dnepropetrovsk: Dnepropetrovsk Institute of Railway Engineers. Dep. in TsNIITEI MPS 09/29/86, No. 7252 railway.
3. Blokhin Evgen, Viktor Danovich, Mykolay Morozov. 1987. „Mathematical model of spatial oscillations of a train of cars as part of a train moving along a straight section of the track”. *Dynamics, strength and reliability of railway rolling stock* 252(34): 4-19.

4. Czech Piotr. 2012. „Determination of the Course of Pressure in an Internal Combustion Engine Cylinder with the Use of Vibration Effects and Radial Basis Function - Preliminary Research”. *Communications in Computer and Information Science* 329: 175-182. DOI: https://doi.org/10.1007/978-3-642-34050-5_21. Springer, Berlin, Heidelberg. ISBN: 978-3-642-34049-9; 978-3-642-34050-5. ISSN: 1865-0929. In: Mikulski Jerzy (eds), Telematics in the transport environment, 12th International Conference on Transport Systems Telematics, Katowice Ustron, Poland, October 10-13, 2012.
5. Czech Piotr. 2012. „Identification of Leakages in the Inlet System of an Internal Combustion Engine with the Use of Wigner-Ville Transform and RBF Neural Networks”. *Communications in Computer and Information Science* 329: 175-182. DOI: https://doi.org/10.1007/978-3-642-34050-5_47. Springer, Berlin, Heidelberg. ISBN: 978-3-642-34049-9; 978-3-642-34050-5. ISSN: 1865-0929. In: Mikulski Jerzy (eds), Telematics in the transport environment, 12th International Conference on Transport Systems Telematics, Katowice Ustron, Poland, October 10-13, 2012.
6. Czech Piotr. 2013. „Intelligent Approach to Valve Clearance Diagnostic in Cars”. *Communications in Computer and Information Science* 395: 384-391. DOI: https://doi.org/10.1007/978-3-642-41647-7_47. Springer, Berlin, Heidelberg. ISBN: 978-3-642-41646-0; 978-3-642-41647-7. ISSN: 1865-0929. In: Mikulski Jerzy (eds), Activities of transport telematics, 13th International Conference on Transport Systems Telematics, Katowice Ustron, Poland, October 23-26, 2013.
7. Danovich Viktor, Angela Malysheva. 1998. „Mathematical model of spatial oscillations of the coupling of five cars moving along a rectilinear section of the track”. *Transport. Stress Loading and Durability of a Rolling Stock* 1: 62-69.
8. Danovich Viktor, Peter Anisimov. 1989. „Oscillations in the horizontal plane of a 4-axle flat wagon with an asymmetrically located heavy cargo”. *Vestnik of the Railway Research Institute* 3: 5-9. ISSN: 2223-9731.
9. Dižo Ján, Miroslav Blatnický, Denis Molnár, Anatolij. 2022. „Calculation of basic indicators of running safety on the example of a freight wagon with the Y25 bogie”. *Communications – Scientific Letters of the University of Zilina* 24(3): B 259-B 266299307. ISSN: 1335-4205. DOI: <https://doi.org/10.26552/com.C.2022.3.B259-B266>.
10. Figlus T. 2019. “A Method for Diagnosing Gearboxes of Means of Transport Using Multi-Stage Filtering and Entropy”. *Entropy* 21(5). DOI: <https://doi.org/10.3390/e21050441>.
11. Figlus T., Lisak S. 2014. “Assessment of the vibroactivity level of SI engines in stationary and non-stationary operating conditions”. *Journal of Vibroengineering* 16(3): 1349-1359.
12. Figlus T., Gnap J., Skrucany T., Sarkan B., Stoklosa J. 2016. “The Use of Denoising and Analysis of the Acoustic Signal Entropy in Diagnosing Engine Valve Clearance”. *Entropy* 18(7). DOI: <https://doi.org/10.3390/e18070253>.
13. Kalker J.J. 1991. “Wheel-rail rolling contact theory”. *Wear* 144: 243-261. ISSN: 0043-1648.
14. Kalker J.J. 1967. „On the rolling of two elastic bodies in the presence of dry friction”. *Doctoral Thesis*. Delft, Netherlands: Delft Technological University.
15. Kampczyk Arkadiusz, Katarzyna Dybeł. 2021. „Integrating surveying railway special grid pins with terrestrial laser scanning targets for monitoring rail transport infrastructure”. *Measurement* 170: 108729. ISSN: 0263-2241. DOI: <https://doi.org/10.1016/j.measurement.2020.108729>.

16. Kovalchuk Vitalii, Mykola Sysyn, Yuriy Hnativ, Artur Onyshchenko, Maksym Koval, Oleksii Tiutkin, Mariana Parneta. 2021. „Restoration of the bearing capacity of damaged transport constructions made of corrugated metal structures”. *The Baltic journal of road and bridge engineering* 16(2): 90-109. ISSN: 1822-4288. DOI: <https://doi.org/10.7250/bjrbe.2021-16.529>.
17. Kurhan Mykola, Dmytro Kurhan, Marina Husak, Nelya Hmelevska. 2022. „Determination of the type and the length for the transition curves on the directions of high-speed train operation”. *Acta Technica Jaurinensis* 15(2): 117-124. ISSN: 2064-5228. DOI: <https://doi.org/10.14513/actatechjaur.00658>.
18. Kurhan Mykola, Dmytro Kurhan, Marina Husak, Nelya Hmelevska. 2022. „Increasing the efficiency of the railway operation in the specialization of directions for freight and passenger transportation”. *Acta Polytechnica Hungarica* 19(3): 231-244. ISSN: 1785-8860. DOI: <https://doi.org/10.12700/APH.19.3.2022.3.18>.
19. Kurhan Mykola, Dmytro Kurhan. 2019. „Providing the railway transit traffic Ukraine - European union”. *Pollack Periodica* 14(2): 27-38. ISSN: 1788-1994. DOI: <https://doi.org/10.1556/606.2019.14.2.3>.
20. Myamlin Serhiy. 2002. *Simulation of railway vehicles dynamics*. Dnepropetrovsk: New ideology. ISBN: 966-8050-04-05.
21. Shatunov Oleksandr, Angela Shvets, Oleg Kirilchuk, Anzhelika Shvets. 2019. „Research of wheel-rail wear due to non-symmetrical loading of a flat car”. *Science and Transport Progress* 4(82): 102-117. ISSN: 2307-3489. DOI: <https://doi.org/10.15802/stp2019/177457>.
22. Shatunov Oleksandr, Angela Shvets. 2019. „Study of dynamic indicators of flat wagon with load centre shift”. *Science and Transport Progress* 2(80): 127-143. ISSN: 2307-3489. DOI: <https://doi.org/10.15802/stp2019/165160>.
23. Sysyn Mykola, Michal Przybylowicz, Olga Nabochenko, Jianxing Liu. 2021. „Mechanism of sleeper-ballast dynamic impact and residual settlements accumulation in zones with unsupported sleepers”. *Sustainability* 13(14): 7740. ISSN: 2071-1050. DOI: <https://doi.org/10.3390/su13147740>.
24. Ye Yunguang, Jing Ning. 2019. „Small-amplitude hunting diagnosis method for high-speed trains based on the bogie frame’s lateral-longitudinal-vertical data fusion, independent mode function reconstruction and linear local tangent space alignment”. *Proceedings of the Institution of Mechanical Engineers, Part F: Journal of Rail and Rapid Transit*. ISSN: 2041-3017. DOI: <https://doi.org/10.1177/0954409718825412>.
25. Zhang Duo, Yinying Tang, Zhongyang Sun, Qiyuan Peng. 2020. „Optimising the location of wagon gravity centre to improve the curving performance”. *Vehicle System Dynamics* ISSN: 1744-5159. DOI: <https://doi.org/10.1080/00423114.2020.1865546>.
26. Zhang Hai, Chenyu Zhang, Fengtao Lin, Xiugang Wang, Gengzhe Fu. 2021. „Research on simulation calculation of the safety of tight-lock coupler curve coupling”. *Symmetry* 13(11): 1997. ISSN: 2073-8994. DOI: <https://doi.org/10.3390/sym13111997>.

Notations

Parameters, variables and functions

- v – movement speed of the wagon;
 R – radius of a curved track section;

y_{pimj}, z_{pimj}	– rail displacement;
η_{vimj}, η_{himj}	– current ordinates of vertical and horizontal irregularities;
h	– superelevation;
q, q^e	– coordinates in relative and transferable motion;
b_g	– width of the cargo mainstay at the place of mainstay;
h_b	– mainstay height;
$2\ell_g$	– distance between elastic-dissipative cargo securing elements;
B_ℓ	– width of the load assignment on the flat wagon frame;
2ℓ	– wagon base;
$2\ell_1$	– bogie base;
h_w	– height of a wagon's body center of mass above the plane of bolster resting on elastic elements;
$2b$	– distance in the lateral direction between the axles of spring assemblies;
$2b_1$	– distance in the lateral direction between the axles of axle boxes;
$2b_2$	– distance between wheel rolling circles;
r	– average wheel rolling circle radius, respectively r_{imj} is the imj -th wheel rolling circle radius;
A_x, A_y	– shifts of the cargo's center of mass in the longitudinal and transverse directions;
T_{ximj}, T_{yimj}	– friction forces arise between the wheels and rails, the components of which are along the X and Y axes;
F_{ximj}, F_{yimj}	– coefficients of pseudosliding in the directions along the axis of the track;
P_{st}	– static pressure of the wheel on the rail with a symmetrical arrangement of cargo on a flat wagon;
$m, m_g, m_{bl}, m_f, m_k, m_p$	– respectively, masses of the body, heavy cargo, bolster, side frame, wheelset, and linear mass of the rail;
I_x, I_y, I_z	– moments of inertia of the body relative to the main central axes;
$I_{xbl}, I_{ybl}, I_{zbl}$	– moments of inertia of bolsters relative to the main central axes;
I_{yf}, I_{zf}	– moments of inertia of the side frames relative to the main central axes;
I_{xk}, I_{zk}	– moments of inertia of the wheelset relative to the main central axes;
k_g	– transverse horizontal stiffness of the corresponding elastic elements between the cargo and the body of the flat wagon;
β_g	– coefficient of viscous friction of the corresponding elastic elements between the cargo and the body of the flat wagon in the transverse horizontal plane;
k_{cs}	– stiffness of the spring set of the central suspension of the bogie when bending (k_{cy}), compressed (k_{cz}), and twisting ($k_{c\psi}$);
β_{cs}	– coefficients of viscous friction of the corresponding dampers (if viscous friction dampers are present);
F_{cs}	– amplitude values of the dry friction forces of the corresponding dampers;

k_{fs}	– rigidity of sets of springs of axle box suspension stage in bending k_{cy} , compressed k_{cz} , and twisting $k_{c\psi}$ side frames;
β_{fs}	– coefficients of viscous friction of the corresponding dampers (if viscous friction dampers are present);
F_{fs}	– amplitude values of the dry friction forces of the corresponding dampers;
f_{fr}	– coefficient of friction of the wheel on the rail;
S_{ψ}	– amplitude value of the moment caused by forces in the side bearings acting on the body and the bolster;
a_{pz}, a_{py}	– inertial track coefficients;
k_z, k_y	– quasi-elastic track coefficients;
χ	– coefficient characterizing the dissipation in the base;
μ_o	– wheel tread surface conicity;
$\alpha_1 = 6 \cdot 10^4$	– coefficient obtained by approximating the nonlinear part of the wheel rolling profile by a cubic parabola;
σ_o	– Heaviside step function.

Received 21.01.2023; accepted in revised form 29.04.2023



Scientific Journal of Silesian University of Technology. Series Transport is licensed under a Creative Commons Attribution 4.0 International License