

## Impact Factor:

ISRA (India) = 6.317  
ISI (Dubai, UAE) = 1.582  
GIF (Australia) = 0.564  
JIF = 1.500

SIS (USA) = 0.912  
ПИИИ (Russia) = 3.939  
ESJI (KZ) = 8.771  
SJIF (Morocco) = 7.184

ICV (Poland) = 6.630  
PIF (India) = 1.940  
IBI (India) = 4.260  
OAJI (USA) = 0.350

SOI: [1.1/TAS](#) DOI: [10.15863/TAS](#)

### International Scientific Journal Theoretical & Applied Science

p-ISSN: 2308-4944 (print) e-ISSN: 2409-0085 (online)

Year: 2022 Issue: 08 Volume: 112

Published: 21.08.2022 <http://T-Science.org>

Issue

Article



**Denis Chemezov**

Vladimir Industrial College

M.Sc.Eng., Corresponding Member of International Academy of  
Theoretical and Applied Sciences, Lecturer, Russian Federation

<https://orcid.org/0000-0002-2747-552X>

[vic-science@yandex.ru](mailto:vic-science@yandex.ru)

## DEMO EXAM AS A FORM OF FINAL CERTIFICATION OF STUDENTS STUDYING IN THE «MECHANICAL ENGINEERING TECHNOLOGY» SPECIALTY

**Abstract:** Information on conducting a demo exam according to WorldSkills standards is given in the article. The features of the task performance at the demo exam in the "Mechanical Engineering CAD" skill by students studying in the "Mechanical Engineering Technology" specialty at the Vladimir Industrial College in 2021 were presented.

**Key words:** Demo exam, WorldSkills, drawing, Mechanical Engineering Technology, Mechanical Engineering CAD.

**Language:** English

**Citation:** Chemezov, D. (2022). Demo exam as a form of final certification of students studying in the «Mechanical Engineering Technology» specialty. *ISJ Theoretical & Applied Science*, 08 (112), 331-335.

**Soi:** <http://s-o-i.org/1.1/TAS-08-112-33> **Doi:**  <https://dx.doi.org/10.15863/TAS.2022.08.112.33>

**Scopus ASCC:** 3304.

### Introduction

A demo exam is a public performance of a practice-oriented special task by students of secondary specialized and higher educational institutions. The special task is developed in accordance with the standards of the WorldSkills Championship [1-2]. One developed task can be used in exams for the final certification of students studying in several related specialties. The essence of the demo exam is to assess the ability of a student of the educational institution to perform the task in real practical conditions.

The demo exam in the Russian Federation has been carried out since 2017. The pilot demo exams were implemented in various skills, which are classified into several blocks: construction and building technology; information and communication technology; creative arts and fashion; manufacturing and engineering technology; social and personal services; transportation and logistics; education. The final certification of graduates in all skills is being implemented as the number of approved demo exam centers increases. The demo exam center is a specially

equipped workshop created within the framework of the national project ("Education").

The main problem in the implementation of the demo exam is the insufficient equipment of the educational institutions with the necessary devices to prepare for the final certification. This is especially true for those exams where special equipment is used. The problem is solved by signing contracts with the enterprises and the educational institutions, where students are trained for the demo exam. The experience of conducting the demo exam in various skills was described in the works [3-9].

In this paper, based on the experience of participation in the WorldSkills Russia Championships, the issues of conducting the demo exam in the "Mechanical Engineering CAD" skill were disclosed and the features of completing the task by students of the Vladimir Industrial College studying in the "Mechanical Engineering Technology" specialty were described.

## Impact Factor:

ISRA (India) = 6.317  
ISI (Dubai, UAE) = 1.582  
GIF (Australia) = 0.564  
JIF = 1.500

SIS (USA) = 0.912  
ПИИЦ (Russia) = 3.939  
ESJI (KZ) = 8.771  
SJIF (Morocco) = 7.184

ICV (Poland) = 6.630  
PIF (India) = 1.940  
IBI (India) = 4.260  
OAJI (USA) = 0.350

### The demo exam

The workshop in the "Mechanical Engineering CAD" skill was opened at the Vladimir Industrial College in 2021. The workshop was created as part of the implementation of the "State support of professional educational organizations in order to ensure that their material and technical base meets modern requirements" event of the federal project ("Young Professionals") of the national project ("Education"). The workshop is designed for ten

workplaces of the exam participants and two expert workplaces. Two monitors, a system unit, a mouse, a keyboard and a 3D printer are installed at each workplace. There is a briefing table in the center for briefing and explaining the task to the participants. There are a color plotter, a multi-function printer, two demo interactive whiteboards and an acoustic speaker. A general view of the workplace in the workshop for the "Mechanical Engineering CAD" skill is presented in the Fig. 1.

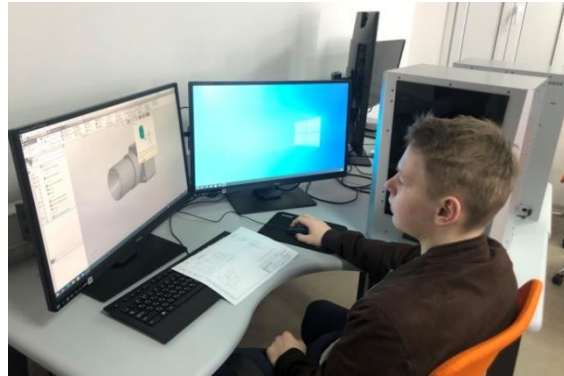

Figure 1 – The general view of the workplace of the participant in the demo exam for the "Mechanical Engineering CAD" skill.



Figure 2 – The demo exam expert certificate.

## Impact Factor:

ISRA (India) = 6.317  
ISI (Dubai, UAE) = 1.582  
GIF (Australia) = 0.564  
JIF = 1.500

SIS (USA) = 0.912  
ПИИЦ (Russia) = 3.939  
ESJI (KZ) = 8.771  
SJIF (Morocco) = 7.184

ICV (Poland) = 6.630  
PIF (India) = 1.940  
IBI (India) = 4.260  
OAJI (USA) = 0.350

The pilot demo exam was implemented in the workshop in December 2021. The task was given 6 hours with breaks, which are negotiated earlier. The demo exam is organized by the chief expert. To assess completed tasks, at least three experts are invited, who must have the certificate giving the right to participate in the evaluation of the demo exam according to the WorldSkills standards. The certificate is valid for two years after successfully passing the exam. The certificate of the author of this article is presented in the Fig. 2.

The demo exam in the "Mechanical Engineering CAD" skill is organized like the WorldSkills Championship. Protocols are drawn up on safety measures, drawing lots, changing the task by 30 percent, etc. The points obtained from the results of the verification of the completed tasks are entered into the CIS system. The difference is the performance of only one module on the demo exam. The participants perform 3-4 different modules in the Championship.

The task is performed using the KOMPAS-3D and Autodesk Inventor Professional software

products. The task is compiled on the basis of the professional modules for students studying in the "Mechanical Engineering Technology" specialty. The similar task can be used for the certification of students studying in the "Special Machines and Devices", "Drafter-Designer", "Aircraft Production" and "Additive Technologies" specialties.

The participants in the demo exam perform the mechanical assembly of a mechanism or unit and the drawings for production. The evaluation of the work performed is carried out according to the following criteria: organization and management of the work; materials, software and technical support; 3D modeling and creating animation; creation of toned images of photographs (2D); the drawings and measurements; reconstruction of the design (reverse engineering) of physical models. The demo exam participant's Skills Passport is generated after scoring [10]. The Skills Passport of one of the participants in the demo exam for the "Mechanical Engineering CAD" skill is presented in the Fig. 3.



Figure 3 – The Skills Passport of a student of the Vladimir Industrial College after completing the task at the demo exam.

Let us consider monitoring the results of the demo exam in the "Mechanical Engineering CAD" skill in the Vladimir region and the Russian Federation. A total of 1,215 students took the demo exam in the "Mechanical Engineering CAD" skill in 2021. Of these, 724 students took the exam in the

"Mechanical assembly and drawings for production" module. A student of the Vladimir Industrial College passed the exam (scored 10.15 points) better than 43% of those who took it in the Russian Federation (313 out of 724 students scored less than 10.15) or better than 90% of those who took it in the Vladimir region

## Impact Factor:

ISRA (India) = 6.317	SIS (USA) = 0.912	ICV (Poland) = 6.630
ISI (Dubai, UAE) = 1.582	ПИИИ (Russia) = 3.939	PIF (India) = 1.940
GIF (Australia) = 0.564	ESJI (KZ) = 8.771	IBI (India) = 4.260
JIF = 1.500	SJIF (Morocco) = 7.184	OAJI (USA) = 0.350

(9 out of 10 students scored less than 10.15). The average result for the Russian Federation was 11.02 points, which is 0.87 points more than the result of a student of the Vladimir Industrial College. The average result for the Vladimir region was 7.51 points. After analyzing the results, we can conclude that the allocated time is not enough to complete the task in full. Therefore, in order to improve performance, it is

necessary to focus on the high-quality implementation of the electronic models of parts, and for the remaining time to produce the drawings, since the significant number of points are also given for them. Comparison of the results of the demo exam in the "Mechanical Engineering CAD" skill in the secondary specialized and higher educational institutions for 2021 is given in the table 1.

**Table 1. The results of the demo exam in the "Mechanical Engineering CAD" skill in the secondary specialized and higher educational institutions for 2021.**

Level of education	Type of learner	Type of certification	Vladimir region		Russian Federation	
			Maximum score	Average score	Maximum score	Average score
Secondary vocational education	Students	Intermediate	-/10.15/25	-/10.15/25	20.97/10.15/25	9.52/10.15/25
	Graduates	Intermediate	10.15/10.15/25	7.51/10.15/25	20.92/10.15/25	12.26/10.15/25
		Final	-/10.15/25	-/10.15/25	23.12/10.15/25	11.14/10.15/25
Higher education	Graduates	Intermediate	-/10.15/25	-/10.15/25	14.2/10.15/25	10.76/10.15/25

*Index/The result of the participant of the Vladimir Industrial College/Maximum score*

### Features of the task

Let us consider the task proposed for execution at the demo exam in the "Mechanical Engineering CAD" skill. It is necessary to create the electronic model of the capture mechanism according to the task. To create this mechanism, the participant is given the drawings of parts that need to be made in three-dimensional view and assemblies, according to which the assembly of the mechanism is carried out. The number of the models of parts (mainly standard parts) included in the mechanism are located in a specific folder. In the task, it may be stipulated to select the required standard part from the corresponding library of the software product.

The following must be created to successfully complete the task:

1. Modeling of the parts and their assembly (the isometric image of the finished mechanism is given with the specification, but without indicating positions);
2. Creation of the drawings (the isometric spaced drawing of the mechanism with the specification and the applied position numbers).

The electronic model of the capture mechanism, created by the participant in the demo exam, is shown in the Fig. 4. The main part of the mechanism (body) is made transparent to show other parts of the assembly. The task was completed in the KOMPAS 3-D software product.

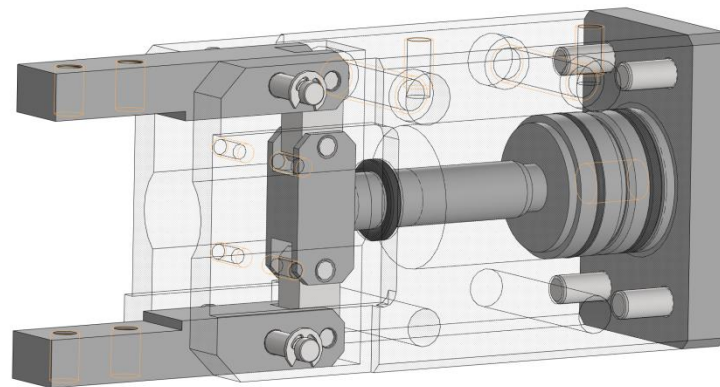

**Figure 4 – The completed 3D model of the mechanism, made by the participant in the demo exam.**

For each part model being created, it is necessary to specify the material, which is indicated on the part drawing in the title block. Threaded elements on the parts are depicted conditionally by means of the corresponding operation. Some part drawings do not

include dimensions. In this case, it is necessary to determine the size yourself from the mating part. Intersections of the part models in the assembly are not allowed.

## Impact Factor:

ISRA (India) = 6.317  
ISI (Dubai, UAE) = 1.582  
GIF (Australia) = 0.564  
JIF = 1.500

SIS (USA) = 0.912  
ПИИИ (Russia) = 3.939  
ESJI (KZ) = 8.771  
SJIF (Morocco) = 7.184

ICV (Poland) = 6.630  
PIF (India) = 1.940  
IBI (India) = 4.260  
OAJI (USA) = 0.350

The evaluation of the finished work is carried out according to criteria that are known only to experts. Each created part model is evaluated in the points. Only the number of linear, diametrical, angular, and other dimensions according to the part drawing are subject to evaluation. The correct assembly of the parts is evaluated in the mechanism. The points are deducted for the absence of some parts in the assembly. The assembly is a connection of the part models through mates.

### Conclusion

Thus, the new form of the certification of graduates in the educational institutions allows assessing the number of important professional skills:

the ability to read the drawings of parts, assemblies, specifications and other technical documentation; the ability to perform three-dimensional modeling in the computer-aided design systems; the ability to create animated videos and photorealistic images; the ability to design elements and parts. The employer will receive the reliable public information about the level of readiness of the young specialist based on the results of the demo exam. Monitoring the databases of the WorldSkills Academy, where graduates' Skills Passports are uploaded, ensures the high-quality selection of candidates for the positions of the technician, mechanic, engineer, designer for machine-building production and related industries.

### References:

1. (n.d.). *Methodology of organizing and conducting a demonstration exam. Appendix No. 1 to the order of the WorldSkills Russia Union dated November 30, 2016 № PO/19*. Retrieved from <https://worldskills.ru>
2. (n.d.). *Demonstration exam on WorldSkills Russia standards*. Retrieved from <https://irorb.ru/files/WS/infode.pdf>
3. Karpenko, L. A. (2018). Demonstration exam on WORLDSKILLS RUSSIA standards: experience of Chelyabinsk radio technical College. *Innovative development of professional education*, № 4 (20), 54-59.
4. Ivanova, M. A. (2018). Demonstration exam on WORLDSKILLS RUSSIA standards as a tool to ensure that the quality of graduate training meets the needs of the Russian economy and an element of independent assessment of the quality of education in the system of secondary vocational education. *Education Management: theory and practice*, №4(32), 87-100.
5. Kurdyumov, S. S. (2019). Problems of the demonstration exam as a tool for determining the level of readiness for professional activity. *Scientific notes of the Orel State University*, No. 4 (85), 246-248.
6. Udod, S. A., Mitina, N. S., & Kopalina, T. V. (2019). *Imperfection of the organization of the demonstration exam in the system of secondary vocational education*. Scientific works of the Central Research Institute of Russian Sign Language. (pp.69-74). Moscow.
7. Lvova, L. S. (2017). Demonstration exam as a stage of sequential transition to the new FGOS SPO. *Accreditation in education*, No. 4 (96), 58-60.
8. Smolina, O. A. (2017). On the formation of a popular qualification assessment system in the WorldSkills forma. *Scientific notes Trans-Baikal State University*. Pedagogical sciences, Vol. 12, No. 2, 32-40.
9. Degterenko, L. N., Bannikov, V. S., & Bannikova, A. N. (2018). Technology of demo exams under Worldskills standards by the example of "Interior Design" professional competence. *Contemporary Higher Education: Innovative Aspect*, Vol. 10, No. 4, 129-139.
10. (n.d.). *Skills Passport*. Retrieved from [https://en.wikipedia.org/wiki/Skills\\_Passport](https://en.wikipedia.org/wiki/Skills_Passport)