

TOOL CONTROL THE CONCENTRATION OF CARBON DIOXIDE IN THE FLUE GAS BOILERS BASED ON THE OPTICAL ABSORPTION METHOD

Oleksandr Vasilevskyi, Ihor Dudatiev, Kostyantyn Ovchynnykov

Vinnytsia National Technical University, Vinnytsia, Ukraine

Abstract. The methodology for controlling the concentration of carbon dioxide in flue gases from boilers is an optical absorption method with improved metrological characteristics. Studies done in the article, provided the new, scientifically-based theoretical and practical results that are essential for improving the accuracy at the required speed process, control the carbon dioxide concentration in dual gas boilers based on the optical absorption method with compensation effect on the factors optical converter.

Keywords: vehicle control, optical measuring transducer, concentration of carbon dioxide absorption spectrum, uncertainty of measurement, reliability of control

NARZĘDZIE KONTROLI STĘŻENIA DWUTLENKU WĘGLA W SPALINACH KOTŁÓW PRACUJĄCE NA PODSTAWIE METODY ABSORPCJI OPTYCZNEJ

Streszczenie. Metodologia kontroli stężenia dwutlenku węgla w spalinach kotłowych wykorzystuje zjawisko absorpcji optycznej przy ulepszonych charakterystykach metrologicznych. Zaprezentowane w artykule badania dostarczyły nowych wyników, opartych na podstawach naukowych i praktycznych, które są niezbędne do poprawy dokładności przy wymaganej szybkości przebiegu procesu kontroli stężenia dwutlenku węgla w podwójnych kotłach gazowych odbywającej się na podstawie metody absorpcji optycznej z kompensacją czynników w przetworniku optycznym.

Słowa kluczowe: sterowanie pojazdem, optyczny przetwornik pomiarowy, stężenie widma absorpcji dwutlenku węgla, niepewność pomiaru, niezawodność sterowania

Introduction

The common disadvantage of most existing methods, with the exception of optical ones, is their low selectivity, that is, often the definition of the concentration of gas hinders the presence of other components. A low threshold of sensitivity, that is, the ability to determine small concentrations of gases, is characteristic only for electrochemical methods of gas analysis. The conducted analysis shows that the best use is the use of optical methods, among which the optical-absorption method [18] is best for solving the problems. Therefore, an important goal of further work is to improve the optimal method for controlling the concentration of components of gases and its unification of the indicative features of the object of control. To do this, it is necessary to solve a number of theoretical and practical tasks [1, 15]:

- To develop a mathematical model for determining the concentration of carbon dioxide in flue gases of boiler installations, which takes into account and compensates for the influence of influence factors (temperature, pressure, humidity) on the parameters of the meter, which will allow to assess the metrological characteristics of the means of control for real operating conditions [3, 4];
- To develop algorithmic organization of adaptation of the control of concentration of carbon dioxide in flue gases of boiler plants to real operating conditions [2, 17].

1. Method

Flue gases of boiler installations with an average concentration of more than 0.1 vol% and their main oscillation-rotational characteristics are presented in Fig. 1.

Analysis of the absorption spectrum [15] shows that the most active region is within the range of 2200–2500 cm^{-1} . In Fig. 1. The absorption of the main components of flue gases of boiler installations in the range of 4–4.5 microns (2200–2500 cm^{-1}) is presented [5, 8, 16].

At the same time, virtually all absorption bands are adjacent to each other (in some cases overlap). In addition, water vapours present in gases occupy a wide range of absorption band lengths. Therefore, the necessary condition is not only the choice of the lengths of absorption of gases in such a way that they are not superimposed on each other, but also to use high-precision radiation sources and receivers (whose breadth of spectrum does not allow the "adjacent" gases to enter). After analysing the lengths of absorption of flue gases, it is necessary to select infrared emitters and receivers according to already known input data [6, 7].

Thus, it is possible to determine the parameters of photodiodes and photodetectors, taking into account the interconnection of the absorption lines. That is, the control points for each gas are such that there are no other absorption lines of other gases that could affect the measurement results.

Graphic modelling of a fragment of the HITRAN database is presented in Fig. 2.

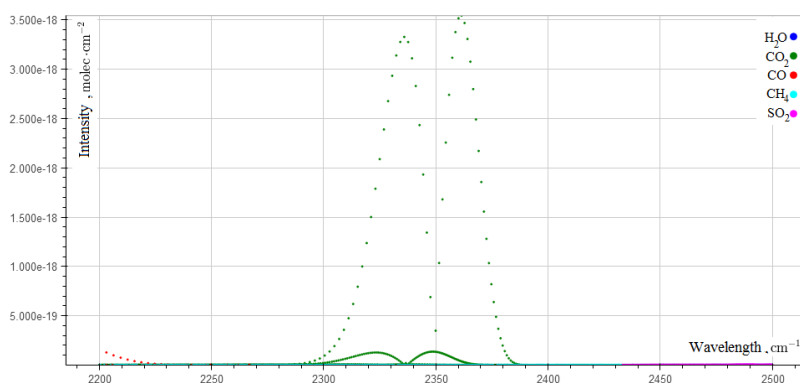

Fig. 1. Absorption spectrum of main components of flue gases of boiler plants in the range of 4–4.5 microns

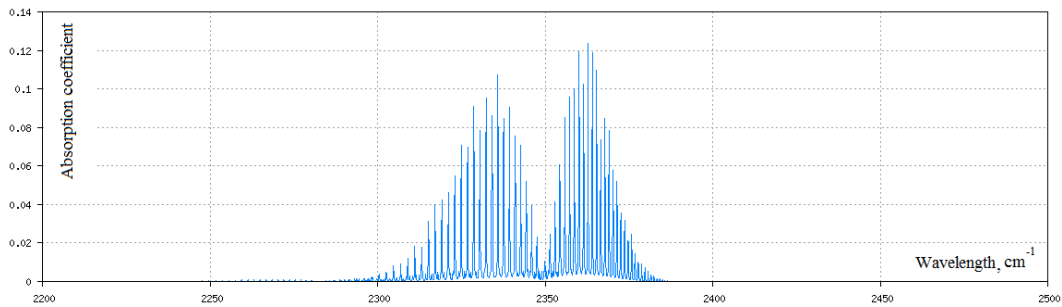

Fig. 2. Fragment of the HITRAN database

As shown on Fig. 2, the absorption spectrum of carbon dioxide in the given range has a complex structure due to overlap of the spectra of gases that are part of its composition, so the absorption coefficient $k(\lambda)$ of the band is expressed by the sum of the absorption coefficients of the individual lines [12, 13]

$$k(\lambda) = \sum_i \frac{S(\lambda_i)}{\pi} \cdot \frac{\sigma}{\sigma^2 + \left(\frac{1}{\lambda} - \frac{1}{\lambda_0}\right)^2}, \quad (1)$$

where S – intensity of the absorption band; λ_i and λ_0 – length and centre of absorption band; σ – absorption band width.

An analytical model of the spectral distribution of gas absorption coefficients calculated on the basis of tables of the intensity of the lines $S(\lambda_0)$ of the radiation of the gases in the indicated spectral range, which corresponds to the calculation of the absorption value in the range 4.1–4.3 microns (2300–2400 cm^{-1}), was used the following approximation [10, 11, 14]:

- The spectrum of the absorption coefficient of gas is described by the sum of the Lorentz distributions with different λ_0 and $S(\lambda_0)$, but the same values of σ L;
- The spectra of absorption coefficients of all gases are given in the spectral band of 2300–2400 cm^{-1} (wavelengths of 4.1–4.3 microns) in increments of 0.01 cm^{-1} . The fulfilment of this condition is necessary for the convenience of analysing gas mixtures and taking into account the influence of influent gases;
- The model takes into account only the lines having the intensity $S \geq 0.1$ [$\text{cm} \cdot \text{atm}$] under normal conditions of measurement.

Model of attenuation of radiation in the environment of flue gases of boiler plants is presented in Fig. 3.

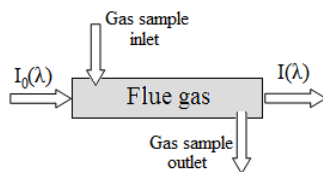

Fig. 3. Model of attenuation of radiation in the environment of flue gases of boiler installations

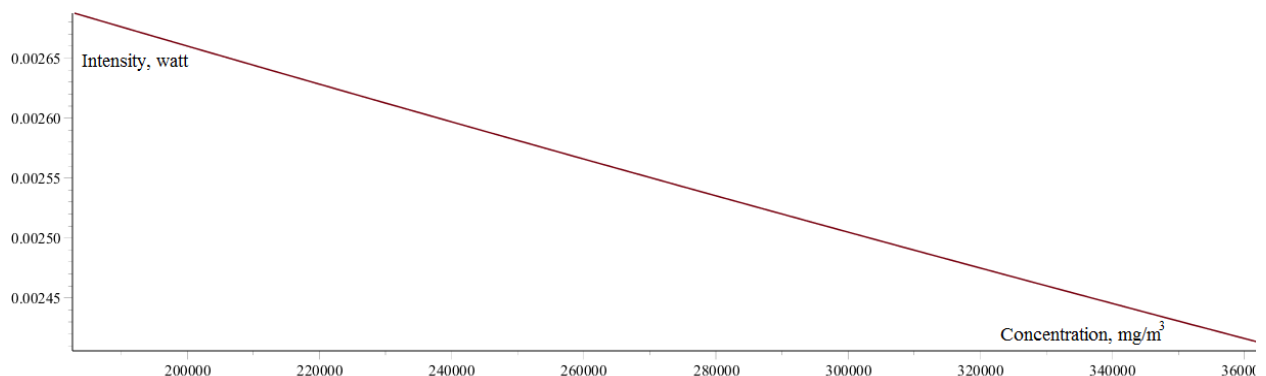

Fig. 4. Simulation of the dependence of the concentration of flue gas on the intensity (in the operating range)

On the basis of Bouguer-Lambert-Beer's law a mathematical model is presented that describes the process of attenuation of radiation in an optical measuring converter and takes into account the main factors that are associated with the features of an object of control that affect its correctness

$$I_l = I_0 \cdot e^{-\int_0^l k_s(\lambda) d\lambda} = I_0 \cdot e^{-\frac{\sigma}{\pi} \cdot \frac{-0,0083 \cdot T}{\sigma^2 + \left(\frac{1}{\lambda} - \frac{1}{\lambda_i}\right)^2} \cdot \frac{M_M \cdot g \cdot h}{R \cdot T} \cdot \frac{C}{M} \cdot l} \quad (2)$$

where I_l – the intensity of the radiation that passed through the gas to be studied; I_0 – initial intensity of radiation; M_M – the molar mass of dry air (0.029 kg/mol); g – acceleration of free fall; h – height, which is the sum of the height of the chimney and the surface of its base above sea level; C – gas concentration (mg/m^3); l – length of the absorption path; σ – absorption band width; M – molar mass of investigated gas; T – temperature of flue gas; R – universal gas became; P_0 – pressure at sea level; P_d – pressure of dilution.

Graphically, the intensity dependence on concentration is depicted in Fig. 4.

A mathematical model [1] of the measuring converter of carbon dioxide concentration in flue gases of boiler plants was also developed.

$$U_F = I_0 e^{-\int_0^l k_s(\lambda) d\lambda} \cdot S_{I0} \cdot S_{RZZ} \quad (3)$$

where S – area of the photosensitive layer of the photodetector, which is illuminated; S_{I0} – integral current sensitivity of the photodiode at unmodulated irradiation; R_{ZZ} – resistance in the feedback loop of the operating amplifier; U_F – output voltage of the photodetector based on a pair of photodiode-operational amplifier.

The simulation was carried out at an input intensity of 3 mW, a feedback resistance of 9.88 M Ω , an integral current sensitivity of the photodiode 5.06 A/m², an area of a photosensitive layer of a photodetector of 26 mm².

The simulation of the dependence of the CO₂ concentration on the voltage in the working and full range is shown in Fig. 5

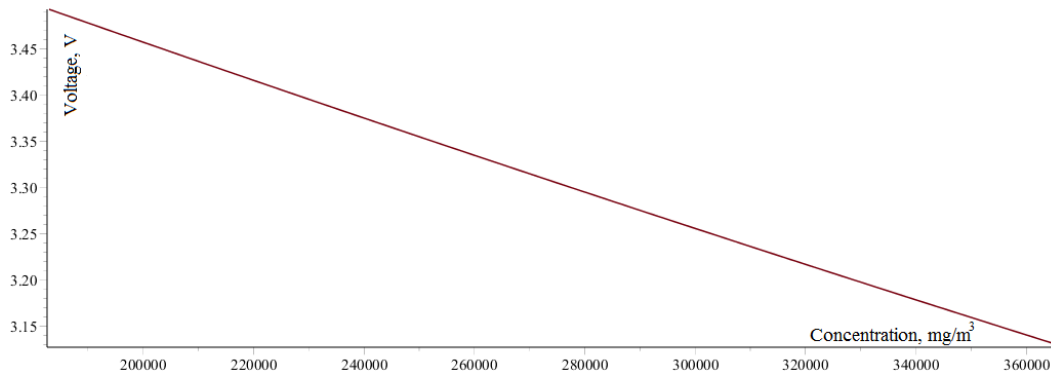

Fig. 5. Dependence of the concentration of CO₂ on the voltage

A device that converts the input value C into a measurable value $U(L, C, \lambda)$ is a measuring transducer. In the control of the composition of flue gases, the function of the measuring transducer is performed by an optical sensor.

The block diagram of the developed optical sensor [2, 3, 4] is shown in Fig. 6

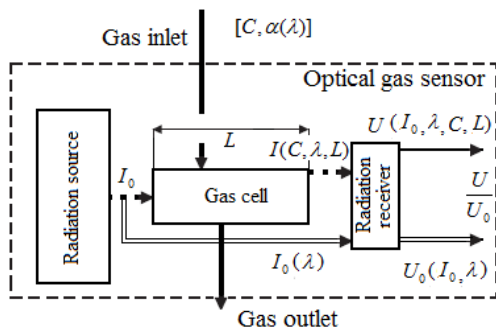

Fig. 6. The block diagram of the developed optical gas sensor

As the output signal of the optical sensor, we will represent the irradiance transmittance in the cuvette with the gas

$$k_{trans}(C, L, \alpha(\lambda)) = \frac{U(I_0, \lambda, C, L)}{U_0(I_0, \lambda)} \quad (4)$$

Using a light emitting diode and a photo diode with spectral characteristics that overlap some band of frequencies $\lambda = \lambda_2 - \lambda_1$. The shifting of the spectral characteristics of the source and the receiver of radiation due to changes in temperature and pressure is inherent in all light emitting diodes and photo-diode. To evaluate the influence of temperature and pressure on the optical sensor and, consequently, on the gas concentration value, we introduce parameters T and P in the function of the spectral characteristics of the source and the receiver of infrared radiation. The photoconductor measures the integral signal and the transfer function of the optical sensor is described by an integral expression

$$k_{trans}(C, L, P, T) = \frac{\int_{\lambda_1}^{\lambda_2} S_{phD}(\lambda, T, P) \cdot I_{LED}(\lambda, T, P) \cdot \exp[-\alpha(\lambda) \cdot L \cdot C] d\lambda}{\int_{\lambda_1}^{\lambda_2} S_{phD}(\lambda, T, P) \cdot I_{LED}(\lambda, T, P) d\lambda} \quad (5)$$

where $S_{phD}(\lambda, T)$ – spectral sensitivity of the photodetector; $I_{LED}(\lambda, T)$ – spectral power of the source; $\alpha(\lambda)$ – spectrum of the absorption coefficient of the gas; L – length of the optical path (the length of the interaction of the radiation with the gas).

The study of the reference and working wavelength for an optical gas sensor was developed and the method of additive-multiplicative compensation of influential factors was developed. It is determined that absorption of carbon dioxide in the 1900 cm⁻¹ range is almost zero. Therefore, as a source (IR) radiation for a reference optical channel, a laser with a working length $\lambda = 1900$ cm⁻¹ was used. It should be noted that in this absorption range CO, NO₂, SO₂, CH₄ is from 10–21 to 10–23 cm/mole, which is several orders of magnitude higher than the absorption of CO₂ in this range.

The length of the working and reference waves and the absorption sensitivity are presented in Fig. 7.

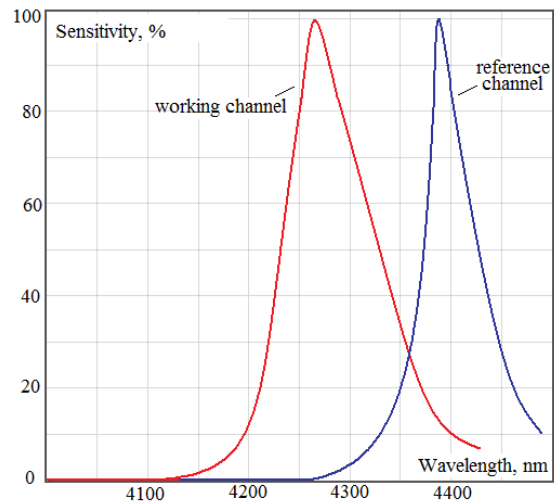

Fig. 7. Dependence of absorption sensitivity on wavelength

Simulation of the intensity of radiation from pressure and temperature is presented (at constant concentration) in Fig. 8.

Development of the method of additive-multiplicative compensation of influential factors.

2. Modelling and experimental results

In work [17], two variants of the algorithm of compensating destabilizing factors for the parameters of the optical converter – linear and nonlinear are considered. Based on research data, algorithms of additive and multiplicative compensation of influencing factors, which are adapted to the object of control, have been developed.

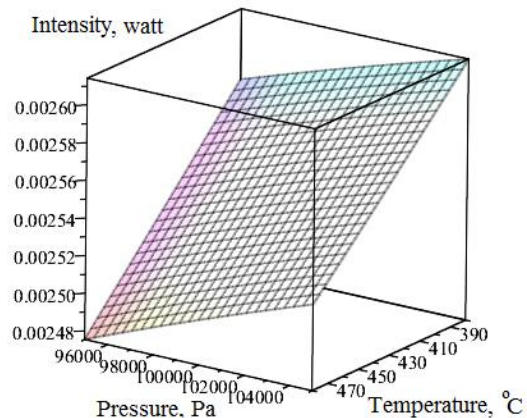

Fig. 8. Dependence of intensity of radiation on pressure and temperature

Intensity at the output of the working optical channel according to the model

$$I_{output.w.ch} = I_{LEDw.ch} e^{k_1} e^{k_2} e^{k_3}, \quad (6)$$

where $k_1 = k_{dis.}$, $k_2 = k_{dissip.CO_2}$, $k_3 = k_{dissip.H_2O+CO+SO_2+CH_4+NO_2}$.

Voltage at the output of the working optical channel according to the model

$$U_{output/w.ch.} = I_{LEDw.ch.} e^{k_1} e^{k_2} e^{k_3} S_{I0w.ch.} S_{w.ch.} R_{zww.ch.} \quad (7)$$

Intensity at the output of the reference optical channel according to the model

$$I_{output.o.ch.} = I_{LEDo.ch.} e^{k_1} e^{k_3} \quad (8)$$

Voltage at the output of the reference optical channel according to the model

$$U_{output.o.ch.} = I_{LEDo.ch.} e^{k_1} e^{k_3} S_{I0o.ch.} S_{o.ch.} R_{zwo.ch.} \quad (9)$$

Let's accept that

$$\begin{cases} S_{I0w.ch.} \approx S_{I0o.ch.} \\ S_{w.ch.} = S_{o.ch.} \\ R_{zww.ch.} = R_{zwo.ch.} \end{cases} \quad (10)$$

Additive compensation of influential factors is expressed due to the intensity of the form

$$\begin{aligned} Add &= I_{out.o.ch.} - I_{output.w.ch.} = \\ &= I_{LEDo.ch.} - \Delta I_{dis.LEDo.ch.} - \Delta I_{k3o.ch.} - I_{0LEDw.ch.} - \\ &- \Delta I_{co_2w.ch.} - \Delta I_{k3w.ch.} - \Delta I_{dis.LEDw.ch.} = \Delta I_{co_2w.ch.} \end{aligned} \quad (11)$$

The additive compensation of the influential factors expressed through the voltage has the form

$$\begin{aligned} Add &= U_{output.o.ch.} - U_{output.w.ch} = \\ &= I_{LEDo.ch.} e^{k_{poz.}} e^{k_3} S_{I0o.ch.} S_{o.ch.} R_{zwo.ch.} - \\ &- I_{LEDp.k} e^{k_{dis.}} e^{k_{dissip.CO_2}} e^{k_3} \times \\ &\times S_{I0w.ch.} S_{w.ch.} R_{zww.ch.} = \Delta U_{co_2w.ch.} \end{aligned} \quad (12)$$

The multiplicative compensation of influential factors is expressed due to the intensity of the form [17, 18]

$$\begin{aligned} Mul &= \frac{I_{output.w.ch}}{I_{output.o.ch.}} = \\ &= \frac{I_{LEDw.ch.} e^{k_1} e^{k_2} e^{k_3}}{I_{LEDo.ch.} e^{k_1} e^{k_3}} = e^{k_{dissip.CO_2}} \end{aligned} \quad (13)$$

The multiplicative compensation of the influential factors expressed due to the voltage has the form

$$\begin{aligned} Mul &= \frac{U_{outputw.ch.}}{U_{output.o.ch.}} = \\ &= \frac{I_{LEDw.ch.} e^{k_1} e^{k_2} e^{k_3} S_{I0w.ch.} S_{w.ch.} R_{zww.ch.}}{I_{LEDo.ch.} e^{k_1} e^{k_3} S_{I0o.ch.} S_{o.ch.} R_{zwo.ch.}} = e^{k_2} \end{aligned} \quad (14)$$

Based on the above equations

$$k_{dissip.CO_2} = \ln Mul.$$

Graphical dependence of the *Add* and *Mul* parameters on the concentration of CO₂ in the range from 0 to 10 vol% shown in Fig. 9

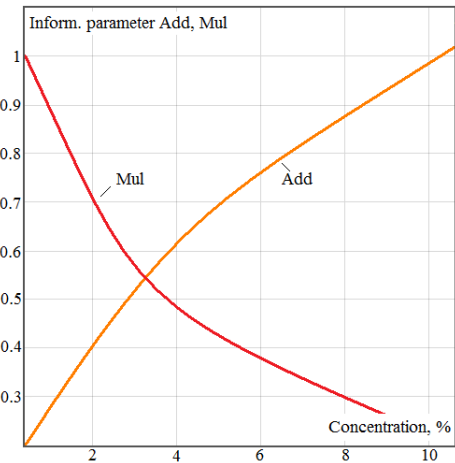

Fig. 9. Dependence of the *Add* and *Mul* parameters on the CO₂ concentration

The modelling of the *Add* and *Mul* parameters from the CO₂ concentration was performed on the basis of experimental data with a 2.5 vol%. Theoretically, the models take into account the intensity at the output of the working and reference channels, but practically in these dependencies, voltage was used, that is

$$\begin{aligned} Add &= U_{output.w.ch.} - U_{output.o.ch.} \Rightarrow Mul = \frac{U_{output.w.ch.}}{U_{output.o.ch.}} \\ Mul &= \frac{U_{output.w.ch.}}{U_{output.o.ch.}} \end{aligned} \quad (15)$$

Having analysed the characteristic in Fig. 9 it is concluded that at concentration of CO₂ up to 3 vol%. It is optimal to use an additive compensation algorithm, and at more than 3 vol% – multiplicative.

3. Discussion of results

To test the mathematical model (3), experimental design studies have been carried out on a model installation (Fig. 10) for determining the concentration of carbon dioxide in flue gases with known content of CO₂ (10–12–14–16 vol%). At a wavelength of 4.267 micron. As a source of radiation, a laser diode based on 1.5 mW InAsSbP was used as a radiation detector – a thin-film thermoelectric receiver (working without cooling).

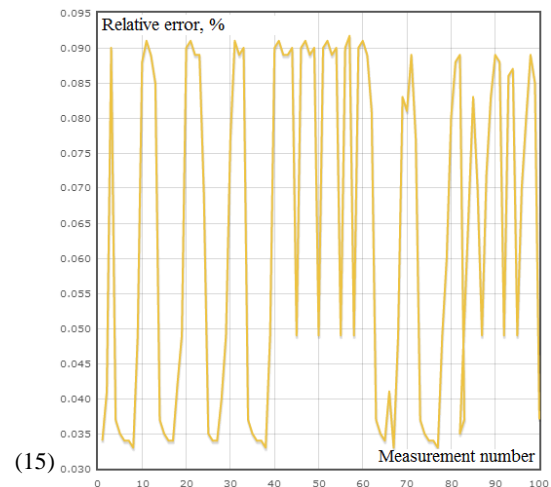

Fig. 10. Graphical representation of the measurement error Δ

Consequently, the maximum absolute, relative and reduced error of concentration determination by means of control make up

$$\Delta = X_m - X_i = 0.092 \text{ vol}\%, \quad (16)$$

$$\delta = \frac{\Delta}{X_i} = \frac{10.092 - 10.000}{10.000} \cdot 100 \% = 0.92 \%, \quad (17)$$

$$\gamma = \frac{\Delta}{X_N} \cdot 100 \% = \frac{0.092}{100} \cdot 100 \% = 0.092 \%. \quad (18)$$

According to international recommendations, the uncertainty of gas concentration measurements with the help of the developed means of control is estimated. For a sample carbon dioxide concentration of 14448 mg/m³, the value of the total standard uncertainty is 121.01 mg/m³. And the increased uncertainty of the measurement result with the reliability of the control of 0.968 is 237.18 mg/m³.

Substituting given and experimental we obtain the value of $\alpha = 0.0312$, $\beta = 0.0010$. Instrumental probability of control $D_I = 0.968$, it is higher compared with the probability of control of known devices of gas analysis (0.8–0.94).

4. Conclusions

The article develops a means for controlling the concentration of carbon dioxide in flue gases of boiler plants on the basis of an opto-absorption method with improved metrological characteristics. The conducted researches have allowed to receive new scientifically-based theoretical and practical results, which are essential for increasing the accuracy with the required speed of control of concentration of carbon dioxide in flue gases of boiler installations on the basis of the opto-absorption method with the compensation of the influence factors of the optical converter.

References

- [1] Kucheruk, V., Kurtynik, I. P., Dudatiev, I.: Automatic control of concentration of flue gases. *Pomiary, Automatyka, Kontrola* 7/2013, 621–623.
- [2] Kucheruk V., Dudatiev I.: Laboratory stand control composition smoke gases of caldrion options. VI International conference on optoelectronic information technologies "Photonics-ODS 2012". VNTU, Vinnytsia 2012.
- [3] Kucheruk V., Dudatiev I.: Optical-gas analysis absorption system with compensation of destabilizing factors. VIII International salon of inventions and new technologies «New Time», Sevastopol 2012, 330–331.
- [4] Kucheruk V., Dudatiev I.: Physical nature metrological select of range of infrared waves to optical absorption methods of control flue gas boilers. II International Scientific Conference in memory of Professor Vladimir Podzharenko Measurement, control and diagnosis in technical systems. MCDTS, Vinnytsya 2013, 26–27.
- [5] Kukharchuk V.V., Bogachuk V.V., Hraniak V.F., Wójcik W., Suleimenov B., Karnakova G.: Method of magneto-elastic control of mechanic rigidity in assemblies of hydropower units. *Proc. SPIE* 10445/2017, 104456A.
- [6] Kukharchuk V.V., Bogachuk V.V., Hraniak V.F., Wójcik W., Suleimenov B., Karnakova G.: Method of magneto-elastic control of mechanic rigidity in assemblies of hydropower units. *Proc. SPIE* 10445/2017, 104456A.
- [7] Kukharchuk V.V., Hraniak V.F., Vedmitskiy Y.G., Bogachuk V.V., et al.: Noncontact method of temperature measurement based on the phenomenon of the luminophor temperature decreasing. *Proc. SPIE* 10031/2016, 100312F.
- [8] Kukharchuk V.V., Kazyv S.S., Bykovsky S.A.: Discrete wavelet transformation in spectral analysis of vibration processes at hydropower units. *Przegląd Elektrotechniczny* 93(5)/2017, 65–68.
- [9] Osadchuk A., Osadchuk I., Smolarz A., Kussambayeva N.: Pressure transducer of the on the basis of reactive properties of transistor structure with negative resistance. *Proc. SPIE* 9816/2015, 98161C.
- [10] Osadchuk A.V., Osadchuk I.A.: Frequency transducer of the pressure on the basis of reactive properties of transistor structure with negative resistance. *Proceedings of the 2015 International Siberian Conference on Control and Communications (SIBCON)*, Omsk 2015.
- [11] Osadchuk V.S., Osadchuk A.V. Radiomeasuring Microelectronic Transducers of Physical Quantities. *Proceedings of the 2015 International Siberian Conference on Control and Communications (SIBCON)*, Omsk 2015.
- [12] Osadchuk V.S., Osadchuk A.V.: The magnetic reactive effect in transistors for construction transducers of magnetic field. *Electronics and Electrical Engineering. Technologija* 3(109)/2011, 119–122.
- [13] Osadchuk V.S., Osadchuk A.V.: The Microelectronic Radiomeasuring Transducers of Magnetic Field with a Frequency Output. *Electronics and Electrical Engineering. Technologija* 4(110)/2011, 67–70.
- [14] Osadchuk V.S., Osadchuk A.V.: The microelectronic transducers of pressure with the frequency. *Electronics and Electrical Engineering. Technologija* 5(121)/2012, 105–108.
- [15] Rothman L.S., Wattson R.B., Gamache R.R., Schroeder J., McCann A.: HITRAN, HAWKS and HITEMP High-Temperature Molecular Database. *Proc. Soc. Photo Optical Instrumentation Engineers* 2471/1995, 105–111.
- [16] Vedmitskiy Y.G., Kukharchuk V.V., Hraniak V.F.: New non-system physical quantities for vibration monitoring of transient processes at hydropower facilities, integral vibratory accelerations. *Przegląd Elektrotechniczny* 93(3)/2017, 69–72.
- [17] Vovna A.V., Zori A.A., Korenev V.D., Hlamov M.G.: Methods and means of the gas components concentration and dust analytical measuring in the mine atmosphere of coal mines. *DonNTU* 1/2013, Donetsk, 47–54.
- [18] Wilkinson J., Bors C., Burgis F., Lorke A., Bodmer P.: Measuring CO₂ and CH₄ with a portable gas analyzer: Closed-loop operation, optimization and assessment. *PLoS ONE* 13(4)/2018: e0193973.

D.Sc. Oleksandr Vasilevskiy

e-mail: o.vasilevskiy@gmail.com

Doctor of Technical Sciences, professor, First Vice Rector, Vinnytsia National Technical University (Ukraine). Academician of the Academy of Metrology Ukraine. Official representative of Ukraine in the International Confederation of Measurements (IMEKO). Research Interests: Theoretical foundations for assessing the quality of measurements of physical quantities.

ORCID ID: 0000-0002-8618-0377

Ph.D. Ihor Dudatiev

e-mail: dudatiev.igor@gmail.com

Ph.D., Senior Lecturer of the Department of Metrology and Factory Automation, Vinnytsia National Technical University. Research Interests: measurement control and diagnostics in technical systems.

ORCID ID: 0000-0002-8810-4706

Ph.D. Kostyantyn Ovchynnykov

e-mail: ovkos1980@gmail.com

Ph.D., Associate Professor of department of Metrology and Factory Automation, Vinnytsia National Technical University. Research Interests: measurement of geometrical sizes of dielectric coatings on conducting bases with the use of conversion of measuring information in tin intervals, software of measuring equipment.

ORCID ID: 0000-0003-4685-1137

otrzymano/received: 30.05.2019

przyjęto do druku/accepted: 15.06.2019

