

**EQUIPMENT TO ADMINISTER IN-DEPTH AMENDMENTS ON LAND  
AFFECTED BY SALINISATION**  
/  
**ECHIPAMENT PENTRU ADMINISTRAT AMENDAMENTE ÎN ADÂNCIME  
PE TERENURILE AFECTATE DE SĂRĂTURARE**

**Bularda M. <sup>1)</sup>, Ungureanu N. <sup>2)</sup>, Istricioaia S. F. <sup>\*3)</sup>, Ciuperca R. <sup>4)</sup>, Mitrache P.M. <sup>5)</sup>**

<sup>1)</sup> University Dunărea de Jos Galați / Romania; <sup>2)</sup> University Politehnica of Bucharest, Faculty of Biotechnical Systems Engineering / Romania; <sup>3)</sup> SCDA Secuieni / Romania; <sup>4)</sup> National Institute of Research Development for Machines and Installations Designed to Agriculture and Food Industry – INMA Bucharest/ Romania; <sup>5)</sup> University of Craiova / Romania

E-mail: [simonapochi@yahoo.com](mailto:simonapochi@yahoo.com)

DOI: <https://doi.org/10.356.33/inmateh-64-01>

**Keywords:** *salted lands, deep loosening, phosphogypsum, phosphogypsum administration*

### ABSTRACT

*This paper presents the results obtained regarding the realization of a functional model of equipment for managing in-depth amendments on salted lands and the results regarding the effect of the work performed in three soil conditions. At the same time, the physical properties of the amendment used (phosphogypsum), determined in laboratory conditions, in order to know the problems that may occur during the application work, are presented.*

### REZUMAT

*In lucrare se prezinta rezultatele obținute privind realizarea unui model funcțional de echipament pentru administrat amendamente in adâncime pe terenurile sărăturate si rezultatele privind efectul lucrării efectuate in trei condiții de sol. Totodată, se prezinta proprietățile fizice ale amendamentului folosit (fosfogips), determinate in condiții de laborator, in scopul cunoașterii problemelor ce pot sa apară in timpul efectuării lucrării de aplicare.*

### INTRODUCTION

At present, agriculture must provide the necessary food for a population of 7.7 billion inhabitants, respectively to an expected 9.0 billion inhabitants in 2040 and 9.8 billion inhabitants in 2050 (FAO, 2012; Ungureanu et al., 2020), which means an increase of 16% in 20 years and respectively 27% in 30 years. By 2050, worldwide food production shall increase by 70% (WRI, 2020) and this increase will be mainly supplied by agriculture. Due to population increase, climate change, freshwater crisis, deterioration of soil quality by inadequate works (Biriș et al., 2007; Biriș et al., 2011; Croitoru et al., 2015; Croitoru et al., 2016; Croitoru et al., 2017), increasing environmental pollution and changing biodiversity (Cujbescu et al., 2019; Bularda et al., 2020), the agriculture must quickly find the solutions to overcome these difficulties and achieve the parameters related to food safety and security. In order to ensure the food requirement in 2050, agriculture must find and prepare strategic solutions and measures to allow a significant increase in agricultural production (Viăduț D.I. et al., 2017a; Viăduț D.I., et al., 2017b; Viăduț D.I., et al., 2018; Viăduțoiu et al., 2016; Viăduțoiu et al., 2017). It is estimated that about 90% of the increase in agricultural production will be made from existing and cultivated land and 10% from new land that will be improved by specific works (embankment, drainage, improvement, etc.) (Bularda M., 2020).

Ensuring the necessary food growth for mankind, complementary to population growth, is largely agricultural. This economic branch has two main ways of action, namely, intensifying activity and increasing agricultural production to maintain or increase the amount of food per capita per year, and expanding agriculture by cultivating new areas to maintain or increase the agricultural area, statistically per capita, as a food source. In the context of those presented, it is known that in 1999 the average specific production worldwide was 0.35 t/inhabitant, 18% higher than 30 years ago. The annual growth rate of world agricultural production was 3% between 1960 and 1970 and below 2% after 1980. In many geographical areas, the average cereal production is very low, of only 0.16 t/inhabitant in Africa and 0.29 t/inhabitant respectively in Asia and Oceania.

With this type of data at hand and taking into account both a specific average level of agricultural production per capita and the estimated number of inhabitants at a given time, the food needs can be calculated and the additional burden on agriculture can be assessed. The task of agriculture to provide food becomes even more difficult as the area of cultivated land per capita fell globally from 0.45 ha/inhabitant in 1961 to 0.25 ha/inhabitant now. Romania returned in 2004 to an average 0.4 ha/inhabitant. To cope with population increase, agriculture must produce 4.0 billion tons of grain, which is double the current situation.

Soil degradation processes imply the need to protect, maintain and improve soil quality (Ungureanu et al., 2019). Salinisation (salinity) is one of the most widespread processes of soil degradation on Earth (Phogat et al., 2020). About 830 million ha of soil area are estimated to be afflicted by salinity and sodicity (Carmeis-Filho et al., 2017; Minhas et al., 2020). In this context, it can be appreciated that the improvement of saline soils and the prevention of secondary salinisation of soils are activities that need to be given more attention (Biggs and Jiang, 2009; Endo et al., 2011).

Annually, the irrigation facilities are degraded by secondary salinisation and wilting (Muyen et al., 2011; Ungureanu et al., 2020) and 125 thousand ha exit the agricultural circuit. On saline and alkaline soils, special attention must be paid to amendments, without which fertilizers cannot have the expected effect. Both amendments and fertilizers aim to increase the productivity of saline soils (Phogat et al., 2020). Gypsum-based amendments ( $\text{CaSO}_4 + 2\text{H}_2\text{O}$ ) are used to improve saline and alkaline soils, with the exception of solodized soils (Ezlit et al., 2010). The exchange reactions result in  $\text{Na}_2\text{SO}_4$ , a salt with a lower alkaline reaction than  $\text{Na}_2\text{CO}_3$ , and at the same time very soluble, which can be easily removed with washing water. As gypsum is used in large quantities in industry, the most widely used amendment today is phosphogypsum, waste from phosphorus and sulfuric acid fertilizer plants, with the following chemical composition: 75-80%  $\text{CaSO}_4 + 2\text{H}_2\text{O}$ ; 5-8%  $\text{P}_2\text{O}_5$ .

Phosphogypsum is administered in a dose of 10-20 t/ha, after ploughing with which the manure is incorporated. It is spread on the surface and introduced into the soil by discus. Phosphogypsum contributes to soil desalination and at the same time improves its permeability to water and as a result increases the storage capacity of water accessible to plants (Wang J., 2020). The in-depth amendment leads to a decrease in the improvement time and an increase in the depth improvement effect. This work must be carried out mechanically on the occasion of another work such as deep loosening or scarification, so that the additional costs for its execution are minimal.

## MATERIALS AND METHODS

The working method consisted in determining the physical-mechanical indices of phosphogypsum, in establishing the agrotechnical requirements for the execution of experimental equipment, in designing and executing a functional model of equipment for managing in-depth amendments on saline lands and in testing it in laboratory-field conditions.

**Determination of physical-mechanical indices of phosphogypsum.** The purpose of the research regarding the determination of the physical-mechanical indices of the phosphogypsum was to highlight the influence of humidity on these indices and to verify some possibilities for their improvement by mixing the phosphogypsum with other materials. The method for determining the flow properties uses for this purpose a cylinder open at the top (Fig. 1a) and provided with a disc-shaped piston fixed on a threaded rod (Krasnicenco A. V., 1963). When the piston is at the bottom, the cylinder is filled with the phosphogypsum passed through a sieve, with the help of a plate the phosphogypsum placed at the top of the cylinder is straightened and the piston will be raised to a certain height  $h$ , which will lead to the evacuation of a certain volume of phosphogypsum:

$$V_h = \frac{\pi}{4} \cdot d^2 \cdot h \text{ [cm}^3\text{]} \quad (1)$$

where:  $V_h$  - volume of phosphogypsum discharged [ $\text{cm}^3$ ];  $d$  - cylinder diameter [cm];  $h$  - piston lift height [cm], by weight of:

$$Q_h = V_h \cdot \gamma_f \text{ [g]} \quad (2)$$

where:

$Q_h$  - mass of the volume of discharged phosphogypsum [g];  $V_h$  - volume of phosphogypsum discharged [ $\text{cm}^3$ ];  $\gamma_f$  - volumetric mass of phosphogypsum [ $\text{g}/\text{cm}^3$ ].

Depending on the flow property, some of the phosphogypsum removed from the cylinder will leak and some will remain at the top. If the part of the leaked phosphogypsum ( $Q_s$ ) is weighed, then flow index is:

$$\eta_c = \frac{Q_s}{Q_h} \quad (3)$$

The ability of the phosphogypsum to form vaults uses the apparatus of Figure 1b, which is in the form of a box provided at the bottom with a hole closed by a calliper (*Krasnicenco A.V., 1963*). When the hole is closed, the box is filled with phosphogypsum in a uniform layer having a height of 40 mm and a pressure of 14.71 kPa is applied over the entire surface for 2 sec; pour the second layer of phosphogypsum to a height of 30 mm and press at the same time. By removing the calliper from the bottom of the box it can be seen that in some humid conditions a vault is formed. The pressure that destroys the vault is considered as an index of the resistance of the formed vault,  $P$  [kPa]. The stronger the vault formed, the greater the ability of the material to form the vault.

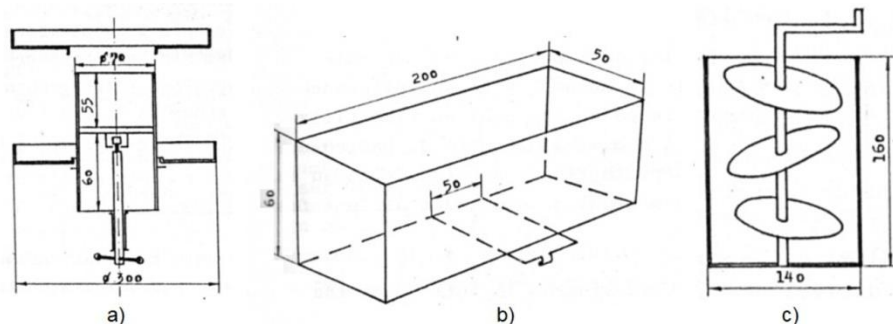

**Fig. 1 - Apparatus for determining the physical and mechanical properties of phosphogypsum**  
*a-apparatus for determining flow properties; b-apparatus for determining the capacity to form a vault;*  
*c-Apparatus for determining the ability to form lumps and adhesion*

The method for determining the properties of forming land lumps and adhering to bodies is limited to mixing the phosphogypsum poured into a vertical cylinder, using a stirred disk mounted inclined to the horizontal plane (Fig. 1c). Phosphogypsum mixed for 75 sec at a speed of  $1 \text{ rot} \cdot \text{s}^{-1}$  is separated with a 5 mm diameter sieve. The land lumps left on the sieve and the amendment that adhered to the agitator's discs are weighed (*Krasnicenco A.V., 1963*). The ratio between their weight and the weight of the phosphogypsum introduced in the device can serve as an index of the ability to form lumps and its adhesion to bodies,  $p$ :

$$p = \frac{G_{\text{lumps} > 5 \text{ mm} + \text{adhering material}}}{G_{\text{total}}}$$

The mentioned properties are influenced by humidity. Thus, in the case of high humidity, the mechanical distribution of the amendment spreaders works poorly or is not able to perform its function. For this reason, phosphogypsum needs to be used only in humidities that allow good administration. In order to have a more suggestive image of the properties of the phosphogypsum, two other materials were used: sand and the mixture of sand + phosphogypsum in equal parts.

**Establishing the agrotechnical requirements imposed for the execution of the experimental equipment.** Agrotechnical requirements to be met by the functional model of equipment for managing in-depth amendments refer to the establishment of some technical characteristics, so that the machine can be aggregated with an existing tractor in operation, to work in complex with another agricultural machine, to allow the organization of a workflow regarding the phosphogypsum supply correlated with the dimensions of the agricultural plots and to execute the work at a quality level as good as possible. Several technical types were analysed in writing and that who best met the imposed agrotechnical requirements was chosen.

**Establishing the influence of the work to be administered in depth on agricultural production and on biometric indices.** These influences were established in a field experience. The experimental variants regarding the application of the depth amendment were performed on three types of soil and considered the application of two values of the phosphogypsum norm at two distances between passes. The plots within the experiment were identical in shape, were placed on three different textural classes (coarse, medium and fine)

and received the treatment of the differentiated intensity of the phosphogypsum, created by two values of the amendment norm (2.0 and 4.0 t/ha) and two values of the distance between passages (1.6 and 3.2 m).

The variants were based on the control variants to which the in-depth amendment does not apply and also the variants were compared with each other (*Pintilie et al, 1980*).

The analysis of the experimental data was done according to the method of calculation and capitalization of the experiments with two factors placed in the subdivided plots. The main factor is the agrofund, in this case the soil texture, with three graduations (coarse, medium and fine) resulting from the percentage of clay content. The coarse texture has 16.8% clay; medium texture 28.7% and fine texture 66.6%. The secondary factor is the applied working variant, with the five graduations, obtained by varying the action intensity of the phosphogypsum that is applied. These graduations are the result of combining the two values of the phosphogypsum norm (2.0 and 4.0 t/ha) with the two values of the distance between the amendment application passages (1.6 and 3.2 m). The large experimental plots each placed on a type of texture were sown with winter wheat and all received the same technological cultivation works (land preparation works, quantity of seed per hectare, fertilization and maintenance works, washing norms/irrigation). The influence of the paper to administer in-depth amendments on the production and on the biometric indices of the plants was determined by collecting samples in three repetitions.

## RESULTS

**Establishing the physical-mechanical indices of phosphogypsum.** To obtain a more suggestive picture of these indices, two other materials were also used: sand and the mixture of sand + phosphogypsum in equal parts. The results obtained from establishing the flow coefficient and the vaulting capacity of the studied materials are presented in Table 1.

Table 1

Results obtained when establishing the flow coefficient and the capacity of studied materials to form the vault

No.	Material	Humidity [%]	Material flow			Material's ability to form a vault		
			Qs [g]	Qh [g]	$\eta$	S [cm <sup>2</sup> ]	F [daN]	P [kPa]
1	Phosphogypsum	8.41	120	195	0.61	14.1	0	0
2		12.12	121	225	0.53	14.1	0.030	0.196
3		13.34	74	211	0.35	14.1	0.419	2.942
4		14.64	47	187	0.25	14.1	1.040	7.355
5		16.02	25	156	0.16	14.1	1.258	8.924
6		17.12	5	137	0.03	14.1	1.316	9.316
7		19.45	0	115	0	14.1	1.273	9.022
8	Mixture of sand + phosphogypsum in equal parts	1.15	207.5	329.5	0.63	14.1	0	0
9		3.25	214	336	0.62	14.1	0	0
10		3.70	211	353	0.59	14.1	0	0
11		4.64	100	290	0.34	14.1	0.647	4.511
12		6.31	33	247	0.13	14.1	1.343	9.512
13		7.37	0	233	0	14.1	1.676	11.866
14		8.34	0	203	0	14.1	1.891	13.337
15	Sand	0.39	331	441	0.75	14.1	0	0
16		0.50	306	418	0.73	14.1	0	0
17		0.77	263	403	0.65	14.1	0	0
18		1.40	135	354	0.38	14.1	0.256	1.765
19		1.89	73	329	0.22	14.1	0.430	3.040
20		2.50	55	325	0.16	14.1	0.487	3.432
21		3.44	0	326	0	14.1	0.638	4.511

Variation of humidity index as a function of humidity for phosphogypsum, sand and sand + phosphogypsum mixture, in equal parts is shown in Figure 2. It is observed that in the case of phosphogypsum, the flow index  $\eta$  has high values at humidity of 8%. This humidity value can only be achieved by forced drying. In its natural state, the humidity of the phosphogypsum can be 10-11% and this in optimal storage conditions. For values of 10-12% humidity, the flow of phosphogypsum is good, but with the increase of humidity over 12% there is a more marked decrease in the flow coefficient so that, over the value of 17%, the phosphogypsum no longer flows.

In the case of other materials, the same phenomenon of the decrease of the flow index takes place with the increase of the humidity, but this happens in lower humidity areas. So, the sand flow index is cancelled

at a humidity of 3.4%, and in the case of the mixture sand + phosphogypsum in equal parts, at 6.3%. Graph of the variation of the resistance index to the breaking of the vault depending on the humidity (Fig. 3) shows that at humidities higher than 12% the phosphogypsum begins to form a vault. The maximum value of the resistance index of the formed vault, P, is 9.316 kPa and occurs at a humidity of 17.1%. Increasing humidity, the P index decreases. For the other materials the range of humidity values at which the vaults are formed is for sand 0.7-4% and for sand + phosphogypsum in equal parts 3.7-9%. It is observed that mixed with sand, the phosphogypsum achieves high values of the vault breaking strength index, respectively 13.337 kPa.

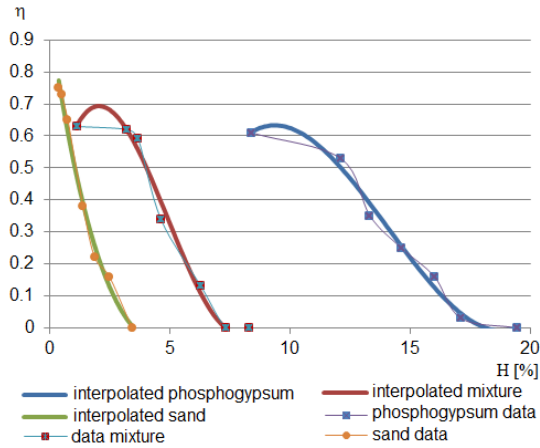

**Fig. 2 - Variation of flow coefficient depending on the humidity for different materials**

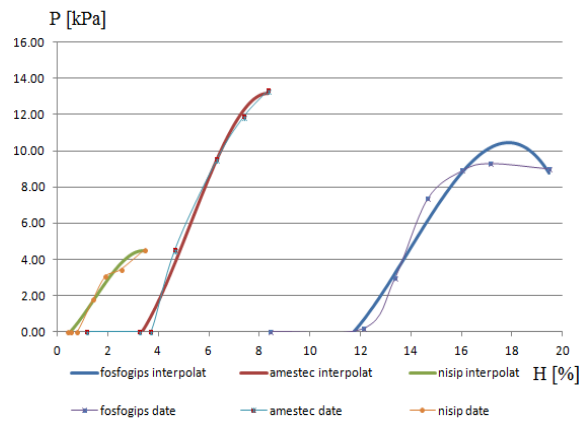

**Fig. 3 - Variation of the capacity to form a vault depending on the humidity for different materials**

Table 2 presents the results obtained in the experiments performed to establish the variation of the phosphogypsum's capacity to form lumps and to adhere to the bodies, namely p.

**Table 2**

**Results obtained when establishing the phosphogypsum's capacity to form lumps and adhere to bodies**

No.	Humidity [%]	G <sub>b</sub> + G <sub>ad</sub> [g]	G <sub>t</sub> [g]	p
1	12.25	0	1245	0
2	13.71	0	1241	0
3	14.77	10	1225	0.008
4	15.49	10	1065	0.009
5	16.94	30	800	0.037
6	18.71	60	825	0.072
7	21.43	135	720	0.182
8	23.40	145	740	0.195
9	27.25	275	805	0.341

Graph of the variation of the index of the capacity to form lumps and of the adhesion to bodies (Fig. 4) shows that phosphogypsum begins to form lumps at humidity higher than 13.7% and begins to adhere to bodies at humidity higher than 21.4%.

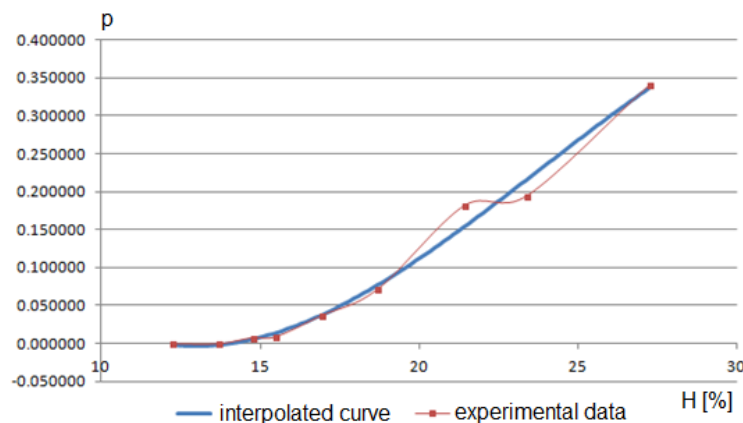

**Fig. 4 - Variation of the ability to form lumps and adhesion of phosphogypsum depending on humidity**



**Agrotechnical requirements for the execution of the functional model of equipment for the administration of in-depth amendments.** The following main agro-technical requirements were taken into account when designing the equipment for in-depth amendments: execution of the in-depth amendment simultaneously with the accomplishment of the deep loosening work of the soil; performing in depth by applying phosphorus in strips at a depth of 30-60 cm within the limits of 500-5000 kg/ha; ensuring the uniform introduction of amendments along the entire length of the course and as much as possible without concentrating it in the lower areas; ensuring the possibility of achieving the intensity of the global amelioration process both by adjusting the dose of phosphogypsum applied and by establishing the corresponding distance between the bands. The working process of the aggregate for the administration of phosphogypsum in depth, U-650 + MAS-60 + EAAA-60 (Fig. 5) is: the U-650 tractor moves the machine to loosen the soil depth, MAS-60. It mobilizes and loosens the soil to a depth of 60 cm. The horizon of 30-60 cm is also involved in this mobilization process. Immediately after the active loosening body is inserted, by free fall, phosphogypsum is dosed and carried to the work area by the equipment to administer in-depth amendments EAAA-60. The intensity of the in-depth amendment process varies by adjusting the dose of amendment introduced into the soil and by establishing the distance between adjacent passages.

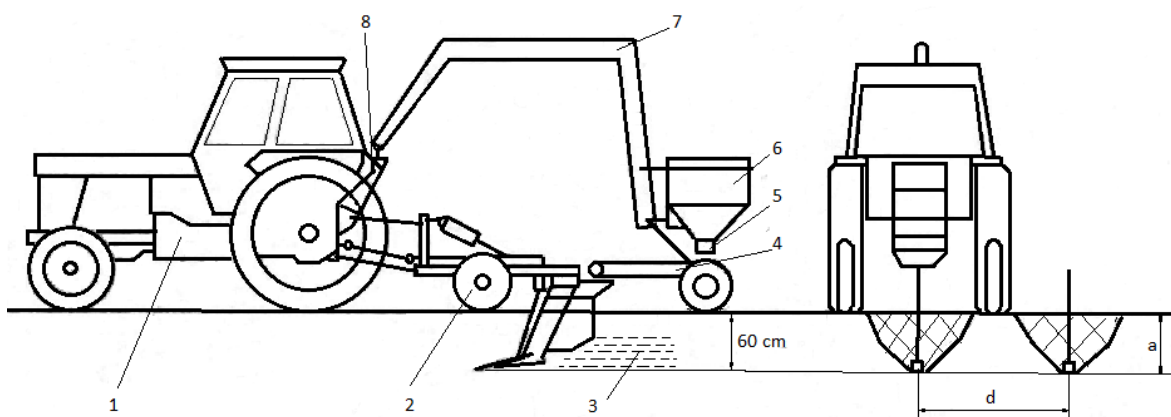

**Fig. 5 - Diagram of the U-650 + MAS-60 + EAAA-60 unit in operation**

1-tractor U-650; 2-deep soil loosening machine MAS-60; 3-phosphogypsum applied in depth; 4-belt mobile conveyor; 5-ring calliper; 6-hopper; 7-spit; 8-connection coupling; a-working depth; d-distance between crossings

**Development of the functional model of equipment for managing amendments in the soil at depth.** Some parts or subassemblies of the EAAA-60 machine were taken from other machines to obtain a construction that is easy to do, cheap and functional. The main components of the unit are: U-650 tractor which is the basic part of the unit, part that provides the energy needed to operate the other agricultural machines; MAS-60 deep soil loosening machine, which engages the suspension mechanism of the U-650 tractor, and by moving in work, the soil is mobilized at a depth of 60 cm; equipment for the administration of the in-depth amendment EAAA-60, which engages also, to the U-650 tractor by means of a special coupling. EAAA-60 equipment provides storage, dosing and training of phosphogypsum in the work process. *The special coupling* is attached to the tractor U-650 so as to allow its aggregation with a worn agricultural machine and at the same time through this coupling it is possible to aggregate a towed machine. If EAAA-60 is not used, it is possible to use the U-650 tractor for any work without the need to disassemble the special coupling. *The EAAA-60 dowel* is made with a vault from the pipe. It is a welded construction having as elements the prop itself, the part comprising a movable ball coupling system which is mounted on the bolt of the special coupling, the grip triangle on the body of the machine for administering amendments and reinforcements. The construction is executed in the form of a module that allows reuse for other machines that would require such an aggregation. The execution of the dowel in the construction with vault allows the movement of the U-650 + MAS-60 + EAAA-60 unit without problems of attachment between the machines. *The elements that ensure storage, the dosing and training of the phosphogypsum* are mounted on a frame, connected to the gripping triangle of the arch with the vault. The movement is transmitted to the conveyor belt from the support wheel of the equipment, which in this way ensures the uniformity of the norm that applies regardless of the speed variations that occur during work. *The takeover funnel* has the role to effectively contribute to the introduction of phosphogypsum in depth.

When the conveyor belt reaches above the pick-up funnel, the transmission is coupled and the amendment is driven, which by free fall reaches the actual funnel provided at the top with elastic rubber walls. In the funnel, the amendment is focused on the flow tube which, through the section it has, it limits the maximum value of the flow rate and through the sides prevents the walls from collapsing before the phosphogypsum reaches the depth. The bottom, cut obliquely, allows the superficial mixing of the phosphogypsum with the soil due to the effect of directed collapse of the walls from the bottom up.

**Experimental results on the influence of amendments administering works on agricultural production and on biometric indices.** The experiment was set up in 1995, in the Corbu-Nou Experimental Field, Brăila County. Amendments were made with two values of the phosphogypsum norm, namely 2.0 and 4.0 t/ha, for two variants of the distance between passages, respectively 1.6 and 3.2 m. The land was then cultivated with wheat, variety Lovrin 41, at a sowing density of 550 plants/m<sup>2</sup>. N100 and P80 fertilization was also applied in the culture technology, and herbicidation with Oltisan Extra, 1 l/ha (*Framework technologies for field crop cultivation, 1989*). Five experimental variants resulted on three textures: V0: witness; V1: amendment norm 4.0 t/ha (N) - distance between passages 3.2 m (D); V2: amendment norm 2.0 t/ha (n) - distance between passages 3.2 m (D); V3: amendment norm 2.0 t/ha (n) - distance between passages 1.6 m (d); V4: amendment standard 4.0 t/ha (N) - distance between passages 1.6 m (d). Experimental results on production, plant density, the number of grains in the ear, TKM (mass of a thousand grains) and plant size are shown in Table 3.

**Table 3**  
Influence of administering in-depth amendments on production and on biometric indices in wheat cultivation

Texture (soil type)	Work variant	Production [kg/ha]	Plants density [pl/m <sup>2</sup> ]	No. of grains in the ear [pieces]	TKM [g]	Plant height [cm]
Coarse (easy)	Witness	2520	454.0	21.0	36.3	77.6
	n, D	2550	468.3	21.3	36.3	10.3
	N, D	2630	458.3	22.0	37.6	72.6
	n, d	3150	458.6	23.3	38.0	76.6
	N, d	3620	462.3	26.6	40.0	80.3
Texture average:		2894	460.3	22.8	37.6	75.4
Medium (medium)	Witness	3670	446.0	23.3	33.3	78.6
	n, D	3930	448.0	24.6	37.0	81.0
	N, D	4100	452.3	25.0	39.3	81.3
	n, d	4230	462.0	27.0	40.3	84.3
	N, d	4310	458.6	28.3	40.6	85.3
Texture average:		4048	453.3	25.6	39.1	82.1
Fine (heavy)	Witness	2310	442.0	19.0	32.3	73.1
	n, D	2530	456.6	19.6	34.3	76.6
	N, D	2640	442.3	20.3	35.0	76.3
	n, d	2840	440.3	22.0	35.6	73.0
	N, d	3220	438.0	23.6	36.3	74.3
Texture average:		2708	443.8	20.9	34.7	74.7

Note: plants/m<sup>2</sup>=pl/m<sup>2</sup> represents the density of plants

Table 4 shows the influence of texture on production and on the biometric indices studied. Considering the coarse control texture, it is observed that wheat production is positively influenced by the average texture where there is an increase of 40%, the influence being very significant, and in the case of fine texture, a decrease in production by 7% resulted, respectively a significant negative influence. These results are explicable considering the better fertility and aerohydric conditions that favour their average texture and respectively the difficult conditions of growth and development of plants on the fine texture where the soil is colder, prone to compaction, with low permeability and lower water recovery capacity. Also in these conditions, plant density decreases on fine texture by 4%, significant negative influence, due to the lower twinning capacity on heavy soils and an insignificant influence of the average texture on plant density. For the same reasons, there was also a very significant influence of the average texture on the number of grains in the ear and a very significant negative influence of the fine texture on the same index.

For TKM, there is a significant negative influence of the fine texture and in the case of plant size a very significant influence of the average texture. It follows that texture is a factor that decisively influences production, the average texture being the most favourable for significant production increases.

Table 4

## Influence of soil texture on production and biometric determinations for winter wheat

Texture	Production				Plants density				No. of grains in the ear				TKM			Plant height				
	kg/ha	Differences		Significance	pl/m <sup>2</sup>	Differences		Significance	pcs	Differences		Significance	g	Differences		Significance	cm	Differences		Significance
		kg/ha	%			pl/m <sup>2</sup>	%			pcs	%			g	%			cm	%	
Coarse (easy)	2890	Wit.	100	Wit.	460.3	Wit.	100	Wit.	22.8	Wit.	100	Wit.	37.6	Wit.	100	Wit.	76.4	Wit.	100	Wit.
Medium (medium)	4050	1106	140.1	xxx	453.3	-0.7	98.5	-	25.6	2.8	112.3	xxx	39.1	1.5	103.9	-	82.1	6.7	109.9	xxx
Fine (heavy)	2710	-180	93.8	0	443.8	-16.5	96.4	0	20.9	-1.9	91.7	000	34.7	-2.9	92.3	0	74.7	-0.7	99.1	-
	DL 5% = 1.19				15.48				0.61				1.99			1.08				
	DL 1% = 1.97				25.62				1.01				3.29			1.77				
	DL 0.1% = 3.70				41.95				1.88				6.16			3.34				

Table 5 shows the influence of the working variant on the production and on the biometric indices for winter wheat in the experiment performed. The control variant is not worked in terms of phosphogypsum in-depth application.

Table 5

## Influence of the working variant on phosphogypsum in-depth application on production and biometric determinations for winter wheat

Working variant	Production				Plants density				No. of grains in the ear				TKM			Plant height				
	kg/ha	Differences		Significance	pl/m <sup>2</sup>	Differences		Significance	pcs	Differences		Significance	g	Differences		Sem-nific.	cm	Differences		Significance
		kg/ha	%			pl/sqm.	%			pcs	%			g	%			cm	%	
Witness	2290	Wit.	100	Wit.	447.0	Wit.	100	Wit.	21.1	Wit.	100	Wit.	35.7	Wit.	100	Wit.	76.7	Wit.	100	Wit.
n, D	3010	720	131.4	xxx	457.7	10.7	102.4	x	21.9	0.8	103.8	-	35.9	0.2	100.6	-	76.0	-0.7	99.1	-
N, D	3130	840	136.7	xxx	451.4	4.4	101.0	-	22.7	1.6	107.6	-	37.3	1.6	104.5	-	76.8	0.1	100.1	-
n, d	3140	1120	148.9	xxx	453.7	6.7	101.5	-	24.1	3.0	114.2	xx	38.0	2.3	106.4	-	78.0	1.3	101.7	-
N, d	3720	1430	162.4	xxx	453.0	6.0	101.3	-	26.2	5.1	124.2	xxx	38.9	3.2	108.9	-	80.0	3.3	104.3	-
	DL 5% = 1.91				9.17				1.60				3.99			6.56				
	DL 1% = 2.78				13.33				2.33				5.81			9.54				
	DL 0.1% = 4.18				20.01				3.49				6.95			14.31				

It is observed that all working variants influence production very significantly, reaching production increases of 62%. These increases are due to the cumulative effects of deep loosening of the soil and the action of phosphogypsum. For biometric indices, the effect of deep loosening (d = 1.6 m) is more obvious and is also manifested in the case of the number of grains in the ear, when the influence is distinctly significant and very significant, with increases of 14% (n = 2.0 t/ha) and 24% (N = 4.0 t/ha). For other biometric determinations, the variants of the work exert insignificant influences. Table 6 shows the combined influence of the considered factors, respectively soil texture and working variants on the agricultural production.

Table 6

## Influence of soil texture and working variant on phosphogypsum in-depth application to wheat production, Lovrin 41 variety

Working variant	Production											
	Coarse texture				Medium texture				Fine texture			
	kg/ha	Differences	Significance	kg/ha	Differences	Significance	kg/ha	Differences	Significance			
Witness	2520	Wit.	100	Wit.	2670	Wit.	100	Wit.	2310	Wit.	100	Wit.
n, D	2550	30	101.2	-	3930	1260	147.2	xxx	2530	220	109	-
N, D	2630	110	104.4	-	4100	1430	153.5	xxx	2640	330	114.5	x
n, d	3150	630	125.0	xxx	4230	1560	158.4	xxx	2840	530	122.9	xxx
N, d	3620	1100	143.6	xxx	4310	1640	161.4	xxx	3220	910	139.4	xxx

DL 5% = 2.49; DL 1% = 3.54; DL 0.1% = 5.13

It was found that on the average texture all working variants have a very significant influence (Fig. 6). Production increases of 47-61% are registered. On the coarse texture, very significant crop increases of 25-43% are registered only on the variants that present an accentuated influence from the point of view of loosening the soil in depth (d = 1.6 m). The same happens on the fine texture where the increases are 22-39%.



Also on the heavy texture there is a significant influence of the increased norm of phosphogypsum (N = 4.0 t/ha). It turns out that, in the first year of application, the working variants have a greater influence where the deep loosening is more intense due to the small distance between the passages. Deep loosening regulates the aerohydric regime of the soil, having immediate effect for all types of texture.

It is also reported that, where the phosphogypsum norm is high (N = 4.0 t/ha), the first signs of the positive intake of phosphogypsum appear. Table 7 shows the influence of texture and working variants on phosphogypsum in-depth application on wheat plant density, Lovrin 41 variety.

It was observed that in the context of the cumulative influence of the two factors there are no significant influences on the degree of twinning, parameter that influences plant density. Only on the average texture is signalled a significant influence on the working variant n, D. The tendency of the average texture and the deep loosening to positively influence the density of the plants is highlighted (Fig. 7).

**Table 7**

**Influence of soil texture and working variant on the phosphogypsum in-depth application on plant density in wheat cultivation, Lovrin 41 variety**

Working variant	Plants density											
	Coarse texture				Medium texture				Fine texture			
	pl/m <sup>2</sup>	Differences		Significance	pl/m <sup>2</sup>	Differences		Significance	pl/m <sup>2</sup>	Differences		Significance
	pl/m <sup>2</sup>	%			pl/m <sup>2</sup>	%			pl/m <sup>2</sup>	%		
Witness	454.0	Wit.	100	Wit.	446.0	Wit.	100	Wit.	442.0	Wit.	100	Wit.
n, D	468.3	14.3	103.1	-	448.0	2.0	100.4	-	456.6	14.6	103.3	-
N, D	458.3	4.3	109.5	-	452.3	6.3	101.4	-	442.3	0.3	100.1	-
n, d	458.6	4.6	101.0	-	462.0	16.0	103.6	x	440.3	1.7	99.6	-
N, d	462.5	8.5	101.9	-	458.6	12.6	102.8	-	438.0	-4.0	99.1	-

DL 5% = 15.28; DL 1% = 22.04; DL 0.1% = 31.24

Table 8 shows the influence of soil texture and working variants on phosphogypsum in-depth application.

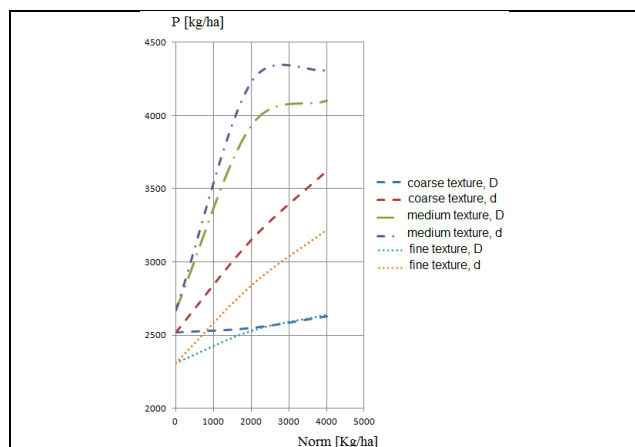

**Fig. 6 - Influence of phosphogypsum norm applied in depth on production on coarse, medium and fine texture**

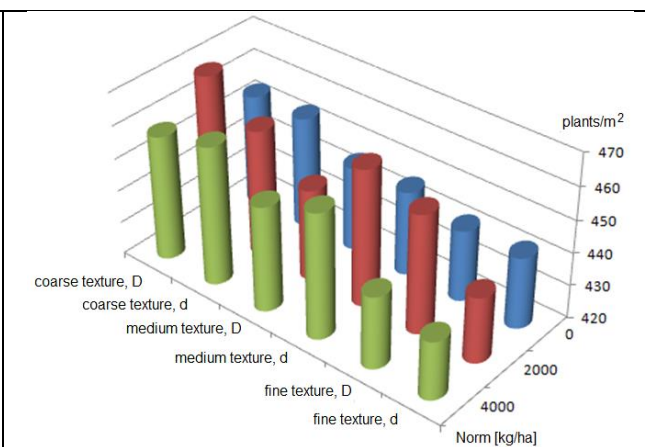

**Fig. 7 - Influence of phosphogypsum norm applied in depth on plant density on coarse, medium and fine texture**

**Table 8**

**Influence of soil texture and working variant on phosphogypsum in-depth application on the number of grains in the ear, in wheat cultivation, Lovrin 41 variety**

Working variant	No. of grains in the ear											
	Coarse texture				Medium texture				Fine texture			
	pcs	Differences		Significance	pcs	Differences		Significance	pcs	Differences		Significance
	pcs	%			pcs	%			pcs	%		
Witness	21.0	Wit.	100	Wit.	23.3	Wit.	100	Wit.	19.0	Wit.	100	Wit.
n, D	21.3	0.3	101.4	-	24.6	1.3	105.6	-	19.6	0.6	103.2	-
N, D	22.0	1.0	104.8	-	25.0	1.7	107.3	-	20.3	1.3	106.8	-
n, d	23.3	2.3	110.9	-	27.0	3.7	115.9	xx	22.0	3.0	115.8	x
N, d	26.3	5.3	125.2	xxx	28.3	5.0	121.4	xxx	23.6	4.6	124.2	xx

DL 5% = 2.43; DL 1% = 3.43; DL 0.1% = 4.89

There is a more significant influence in the case of medium texture and in the case of works characterized by a higher degree of loosening of the other types of texture (Fig. 8). At the same time, it is observed that the action of phosphogypsum begins to manifest itself, which at the working variants with high amendment norms (N = 4.0 t/ha) leads to increases of the number of grains in the ear of over 20%. For the other working variants the influences are insignificant. Table 9 shows the influence of soil texture and working variants on phosphogypsum in-depth administration on TKM (mass of a thousand grains).

Table 9

Influence of soil texture and working variants on phosphogypsum in-depth application on the TKM for winter wheat, Lovrin 41 variety

Working variant	TKM											
	Coarse texture				Medium texture				Fine texture			
	g	Differences		Significance	g	Differences		Significance	g	Differences		Significance
	g	%	g		g	%	g		g	%		
Witness	36.3	Wit.	100	Wit.	38.3	Wit.	100	Wit.	32.3	Wit.	100	Wit.
n, D	36.3	0.0	100.0	-	37.0	-1.3	96.6	-	34.3	2.0	106.2	-
N, D	37.6	1.3	103.6	-	39.3	1.0	102.6	-	35.0	2.7	108.3	-
n, d	38.0	1.7	104.7	-	40.3	2.0	105.2	-	35.6	3.3	110.2	-
N, d	40.0	3.7	110.2	-	40.6	2.3	106.0	-	36.3	4.0	112.4	-

DL 5% = 5.48; DL 1% = 7.77; DL 0.1% = 11.20

It is found that the mentioned factors do not influence the studied parameter significantly (Fig. 9). The greatest influence is presented by the variants with accentuated loosening.

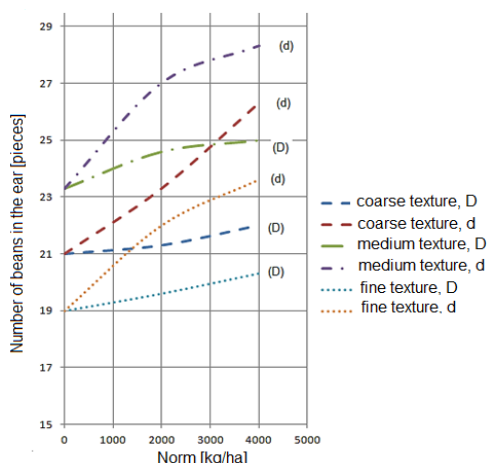

Fig. 8 - Influence of phosphogypsum norm applied in depth on the number of grains in the ear on the coarse, medium and fine texture

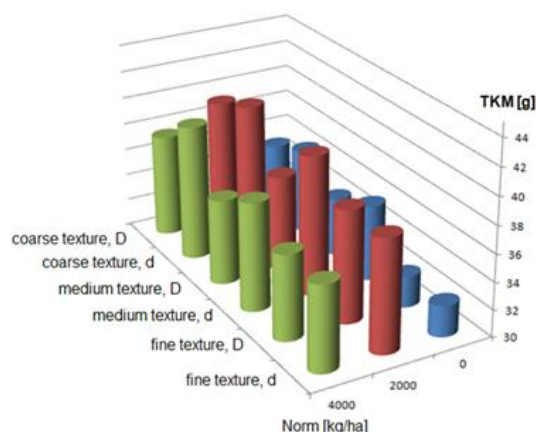

Fig. 9 - Influence of the phosphogypsum norm applied in depth on the TKM on coarse, medium and fine texture

Table 10 shows the combined influence of soil texture and working variants on in-depth administration of phosphogypsum on the size of winter wheat plants, Lovrin 41 variety, in the experimental field Corbu-Nou, Brăila County.

Table 10

Influence of soil texture and working variant on phosphogypsum in-depth application on the height of the plants, to winter wheat, Lovrin 41 variety

Working variant	The height of the plants											
	Coarse texture				Medium texture				Fine texture			
	cm	Differences		Significance	cm	Differences		Significance	cm	Differences		Significance
	cm	%	cm		cm	%	cm		cm	%		
Witness	77.6	Wit.	100	Wit.	78.6	Wit.	100	Wit.	73.6	Wit.	100	Wit.
n, D	70.3	-7.3	90.6	-	81.0	2.4	103.0	-	76.6	3.0	104.1	-
N, D	72.6	-5.0	93.5	-	81.3	2.7	103.4	-	76.3	2.7	103.7	-
n, d	76.6	-1.0	98.7	-	84.3	5.7	107.3	-	73.0	-0.6	99.2	-
N, d	80.3	2.7	103.5	-	85.3	6.7	108.5	-	74.3	-0.7	100.9	-

DL 5% = 10.74; DL 1% = 15.11; DL 0.1% = 21.44

It is observed that size parameter, the height of the plants, is not significantly influenced by the two factors presented above (Fig. 10).

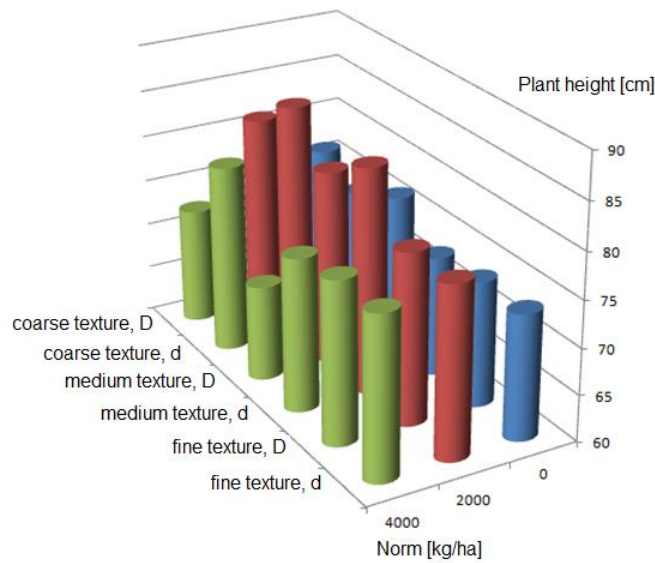

Fig. 10 - Influence of phosphogypsum norm applied in depth on plant height on coarse, medium and fine texture

Analysing the influence of soil texture specified by the clay content and the influence of working variants on phosphogypsum in-depth application, a series of curves have been established that highlight the dependence of agricultural production on the two factors. For a clearer presentation, the curves are presented in two groups in Figure 11 (witness (no amendment in depth) - nD - ND) and Figure 12 (witness (no amendment in depth) - nd - Nd).

It is observed that, in all cases, the decrease or increase of the clay content leads to the decrease of the production. The maximum values of the production are found in the case of applying an energetic loosening of the soil ( $d = 1.6$  m) and at a high norm of phosphogypsum ( $N = 4.0$  t/ha), followed by the variant in which the phosphogypsum norm is low ( $n = 2.0$  t/ha). It turns out that in the first phase the immediate effect of deep loosening is manifested and only in the second phase is the action of phosphogypsum proportional to the administered norm manifested, against the background of a lighter loosening ( $D = 3.2$  m). At all textures, the working variants bring production increases (all the curves with the working variants are above the witness curve).

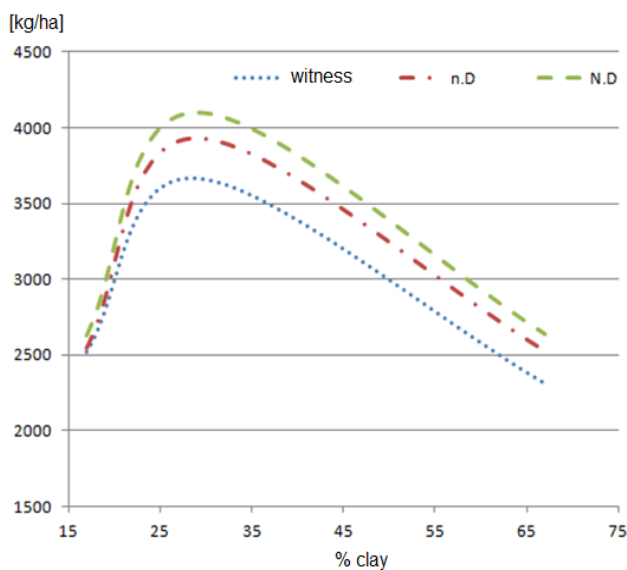

Fig. 11 - Influence of soil texture and working variants on phosphogypsum in-depth application ( $D = 3.2$  m) on production

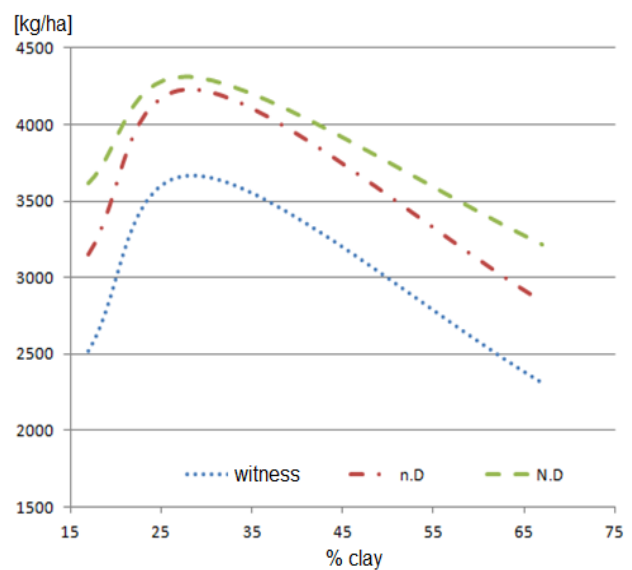

Fig. 12 - Influence of soil texture and working variants on phosphogypsum in-depth application ( $d = 1.6$  m) on production

## CONCLUSIONS

Phosphogypsum can be used properly when it has a humidity of 10-12% and application should be made in the warmer and drier periods of the year, and storage must be done in the best possible conditions. The maximum ameliorating effect of phosphogypsum applied in depth is obtained only when the whole complex of pedo-hydro-agro-ameliorative measures is carried out (soil loosening, irrigation / washing, mole drainage, proper performance of the basic works of soil).

The equipment for the administration of in-depth amendments EAAA-60 works in the unit with the U-650 tractor and the MAS-60 soil loosening machine. By applying a norm of 4.0 t/ha, in bands spaced at 1.6 m, production increases of about 40% were obtained. In the first year of application, the effect of deep loosening becomes more obvious and in cumulation with the effect of phosphogypsum applied in depth, leads to increases in agricultural production by over 25%.

Medium-textured soils respond very well to the measures applied through a higher production capacity, to help cover the costs of the improvement works. The EAAA-60 equipment is intended to work on saline terrain, but it can also be used on soils with salinisation potential, in order to prevent this phenomenon. In this case, the efficiency of the works is higher because the expenses are made on an already productive land, so that financial efforts are covered to a greater extent.

Incorporation of phosphogypsum in depth and deep loosening are heavy works that are performed with high energy consumption, hence they should be made on raw land, where possible or on the move, and the condition of the drive wheels is good. This avoids unjustified fuel consumption and additional wear and tear due to skating. On the ground discussed at the mentioned works, skating can reach 30-35%, and on ploughing the execution of works to incorporate phosphogypsum in depth or mole drainage cannot be performed.

Immediately after the execution of the deep loosening lines, the work must be intervened on by ploughing or discing the soil in order to avoid its drying in the mobilized area. It creates the possibility of obtaining a better quality for surface tillage works, a high and uniform degree of crushing over the entire surface, a constant humidity in the superficial horizon and in depth with positive repercussions on the uniformity of emergence and of growth and development of the plants.

The onset of Na ion replacement reactions in the soil adsorbent complex with Ca in the phosphogypsum composition occurs in the presence of water. Also, water dissolves some of the phosphogypsum that it transports into permeable spaces, thus increasing the area of influence of the amendment. In this context, after applying the phosphogypsum to the surface and in depth and after homogenizing it with the soil, respectively the cultivation of the land, it is recommended to apply increased watering rules or to monitor the existence of a natural water supply that contributes to the growth and development of cultivated plants, but which should also lead to the passage of Na into the composition of soluble salts which will later be taken up by other quantities of water and discharged outside the perimeter.

When applying in-depth amendments, the conditions imposed on the work of deep loosening of the soil must be observed. After a period of 6-12 months, during which sodium replacement reactions occur with calcium, it is necessary to carry out the mole drainage work, and then the intensification of the irrigation / washing works in order to take over the resulting salts and eliminate them outside the perimeter.

## ACKNOWLEDGEMENT

This work was supported by a grant of the Romanian Ministry of Research and Innovation CCDI - UEFISCDI, Project INNOVATIVE TECHNOLOGIES FOR IRRIGATION OF AGRICULTURAL CROPS IN ARID, SEMIARID AND SUBHUMID-DRY CLIMATE, project number PN-III-P1-1.2-PCCDI-2017-0254, Contract no. 27 PCCDI / 2018, within PNCDI III.

## REFERENCES

- [1] Biggs T.W., Jiang B.B., (2009), Soil salinity and exchangeable cations in a wastewater irrigated area, India, *Journal of Environmental Quality*, vol. 8, pp. 887-896;
- [2] Biriş S.Şt., Maican E., Faur N., Vlăduţ V., Bungescu S., (2007), FEM model for appreciation of soil compaction under the action of tractors and agricultural machines, *Proceedings of the 35<sup>th</sup> International Symposium on Agricultural Engineering "Actual Tasks on Agricultural Engineering"*, pp. 271-280, ISSN 1333-2651, Opatija/Croatia;

- [3] Biriş S.Şt., Maican E., Ungureanu N., Vlăduţ V., Murad E., (2011), Analysis of stress and strain distribution in an agricultural vehicle wheel using finite element method, *Proceedings of the 39<sup>th</sup> International Symposium on Agricultural Engineering "Actual Tasks on Agricultural Engineering"*, pp.107-118, ISSN 1333-2651, Opatija/Croatia, WOS: 000290918800010;
- [4] Bularda M., (2020), Contributions to the mechanization of the work to administer in-depth amendments on the lands affected by salinisation (Contribuţii privind mecanizarea lucrării de administrat amendamente în adâncime pe terenurile afectate de sărăturare), *Galaţi University Press*, ISBN 978-606-696-184-4;
- [5] Bularda M., Vişinescu I., Ghiorghe A., Vlăduţ V., Cujbescu D., (2020), The effect of conservative agricultural works on soil and field plants and optimized mechanization technologies, *INMATEH – Agricultural Engineering*, vol. 61 (2), pp. 323-338, DOI: <https://doi.org/10.35633/inmateh-61-35>;
- [6] Carmeis-Filho A.C.A., Penn C.J., Crusciol C.A.C., Calonego J.C., (2017), Lime and phosphogypsum impacts on soil organic matter pools in a tropical Oxisol under long-term no-till conditions, *Agriculture, Ecosystems & Environment*, vol. 241, pp. 11-23;
- [7] Croitoru Şt., Marin E., Bădescu M., Vlăduţ V., Ungureanu N., Manea D., Boruz S., Matei Gh., (2015), Agrotechnical and energetic characteristics of new designed subsoiler, *Proceedings of the 43<sup>th</sup> International Symposium on Agricultural Engineering "Actual Tasks on Agricultural Engineering"*, pp. 165-176, Opatija, Croatia, WOS: 000373450700014;
- [8] Croitoru Şt., Vlăduţ V., Marin E., Matache M., Dumitru I., (2016), Determination of subsoiler's traction force influenced by different working depth and velocity, *Proceedings of the 15<sup>th</sup> International Scientific Conference "Engineering for Rural Development"*, vol. 15, pp. 817-825, Jelgava/Latvia;
- [9] Croitoru Şt., Vlăduţ V., Voicea I., Gheorghe Gh., Marin E., Vlăduţoiu L., Moise V., Boruz S., Pruteanu A., Andrei S., Păunescu D., (2017), Structural and kinematic analysis of the mechanism for arable deep soil loosening, *Proceedings of the 45<sup>th</sup> International Symposium on Agricultural Engineering "Actual Tasks on Agricultural Engineering"*, pp. 207-216, Opatija/Croatia;
- [10] Cujbescu D., Ungureanu N., Vlăduţ V., Persu C., Oprescu M.R., Gheorghită N.E., (2019), Field testing of compaction characteristics for farm tractor Universal 445, *INMATEH – Agricultural Engineering*, vol. 59(3), pp. 245-252, WOS: 000504038200028;
- [11] Endo T., Yamamoot S., Larinnaga J.A., Fujiyama H., Honna T., (2011), Status and causes of soil salinisation of irrigated agricultural land in southern Baja California, Mexico, *Applied and Environmental Soil Science*, vol. 2011, article ID 873625, 12 p.;
- [12] Ezlit Y.D., Smith R.J., Raine S.R., (2010), A review of salinity and sodicity in irrigation, *CRC for Irrigation Futures, Irrigation Matters Series*, no. 01/10;
- [13] Krasnicenco A.V., (1963), Agricultural Machinery Manufacturer's Manual (Manualul constructorului de maşini agricole), vol. I-II, *Technical Publishing*, Bucharest/Romania;
- [14] Minhas P.S., Ramos T.B., Ben-Gal A., Pereira L.S., (2020), Coping with salinity in irrigated agriculture: Crop evapotranspiration and water management issues, *Agricultural Water Management*, vol. 227, 105832;
- [15] Muyen Z., Moore G.A., Wrigley R.J., (2011), Soil salinity and sodicity effects of wastewater irrigation in South East Australia, *Agricultural Water Management*, vol. 99, pp. 33-41;
- [16] Phogat V., Mallants D., Coxa J.W., Šimůnek J., Oliver D.P., Awad J., (2020), Management of soil salinity associated with irrigation of protected crops, *Agricultural Water Management*, vol. 227, 105845;
- [17] Pintilie C., Budoi Gh., (1980), Agrotechnics and experimental technique (Agrotehnică şi tehnică experimentală), *Didactic and Pedagogical Publishing House*, Bucharest/Romania;
- [18] Ungureanu N., Vlăduţ V., Cujbescu D., (2019), Soil compaction under the wheel of a sprayer, *8<sup>th</sup> International Conference on Thermal Equipment, Renewable Energy and Rural Development (TE-RE-RD), E3S Web-of-Conferences*, vol. 112, 03027, 6-8.06.2019, Târgovişte/Romania;
- [19] Ungureanu N., Vlăduţ V., Voicu Gh., (2020), Water scarcity and wastewater reuse in crop irrigation, *Sustainability*, vol. 12, no. 21, 9055, WOS: 000589697700001;
- [20] Vlăduţ D.I., Vlăduţ V., Grigore I., Biriş S.Şt., (2017a), Experimental research on qualitative indices of work for equipment for seedbed preparation in conservative system, *16<sup>th</sup> International Scientific Conference "Engineering for Rural Development"*, vol. 16, pp. 1174-1179, Jelgava/Latvia;
- [21] Vlăduţ V., Gheorghe G., Marin E., Biriş S.Şt., Paraschiv G., Cujbescu D., Ungureanu N., Găgeanu I., Moise V., Boruz S., (2017b), Kinetostatic analysis of the mechanism of deep loosening system of arable



- soil, *Proceedings of the 45<sup>th</sup> International Symposium on Agricultural Engineering "Actual Tasks on Agricultural Engineering"*, pp. 217-228, Opatija, Croatia, WOS: 000432420200022;
- [22] Vlăduț D.I., Biriș S., Vlăduț V., Cujbescu D., Ungureanu N., Găgeanu I., (2018), Experimental researches on the working process of a seedbed preparation equipment for heavy soils, *INMATEH – Agricultural Engineering*, vol. 55 (2), pp. 27-34, WOS: 000445181000004;
- [23] Vlăduțoiu L., Andrei T., Marin E., Vlăduț V., Biriș S.Șt., Matache M., Fechete L., Dumitru I., Kiss I., (2016), Determination of soil resistance related to wear of a chisel share, *Proceedings of the 44<sup>th</sup> International Symposium on Agricultural Engineering "Actual Tasks on Agricultural Engineering"*, pp. 187-194, Opatija/Croatia;
- [24] Vlăduțoiu L., Cârdei P., Vlăduț V., Fechete L., (2017), Modern trends in designing and selecting the machine / equipment for soil deep tillage, *16<sup>th</sup> International Scientific Conference "Engineering for Rural Development"*, vol. 16, pp. 1415-1420, Jelgava/Latvia;
- [25] Wang J., (2020), Utilization effects and environmental risks of phosphogypsum in agriculture: a review, *Journal of Cleaner Production*, vol. 276, 123337;
- [26] \*\*\*FAO, (2012), Coping with water scarcity - an action framework for agriculture and food security, FAO Water Reports 38, *Food and Agriculture Organization of the United Nations* (<http://www.fao.org/3/a-i3015e.pdf>);
- [27] \*\*\**Framework technologies for field crop cultivation (Tehnologii cadru pentru cultura plantelor de câmp)* (1989), Academy of Agricultural and Forestry Sciences (Academia de Științe Agricole și Silvici), Bucharest;
- [28] \*\*\*WRI, (2020), Food. Supporting agriculture, environment, and sustainable development, *World Resources Institute* (<https://www.wri.org/our-work/topics/food>).