



Emanoil Toma

The Use of Current Generators in Electrical Converter Drives for Stepper Motors

This paper presents some ways to realize electrical converters for stepper motor drives. The first part analyzes aspects for unipolar stepper motor and use of constant current generators. The second part presents current sources based on peak limiting current through the inductance of motor coil. A complete drive module for bipolar stepper motor was conceived and simulation results confirm their functionality.

Keywords: current limiting, micro-stepping, Pspice simulation.

1. Introduction

A stepper motor can be considered a digital electromechanical system wherein each electrical pulse input moves the rotor by a discrete angle called the step angle and hence the name stepping motor.

Stepper motors are used in commercial and industrial applications because of their high reliability, low cost, high torque at low speeds and a simple construction that operates in almost every environment [2].

Using a stepper motor is possible to design applications in simple open-loop control system. In this case mechanical actuated system, have low acceleration with static loads.

Stepper motor has the advantage of producing high torque at low speed. Stepper motor has holding torque which allows keeping its position firmly when not turning. Holding its position is useful for intended application where the motor will be started and stopped. In this time the force of the motor's momentum acting against the motor remains present. The results will be unnecessary of brake mechanism.

A stepper motor requires a signal generator and a pulse distributor power static switching like is showed in figure 1.

The forcing of current through stepper's phases can be realized in many ways: Series resistance, resistors and capacitors, constant current electronic generator, two power supply voltage source and "chopper" method [1], [5].

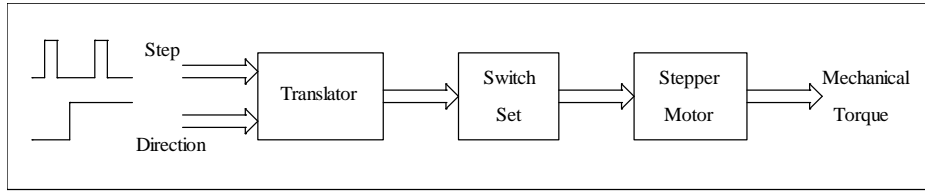

Figure 1. Stepper motor drive elements

2. Simulations for unipolar stepper motor drivers

For experimental set a so called "eight wires" hybrid stepper motor was used. This can be configured as unipolar or bipolar mode connection (figure 2)

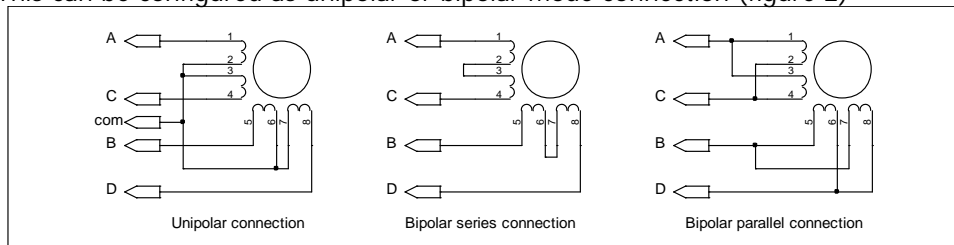

Figure 2. Connection of "8 wires" Stepper Motor

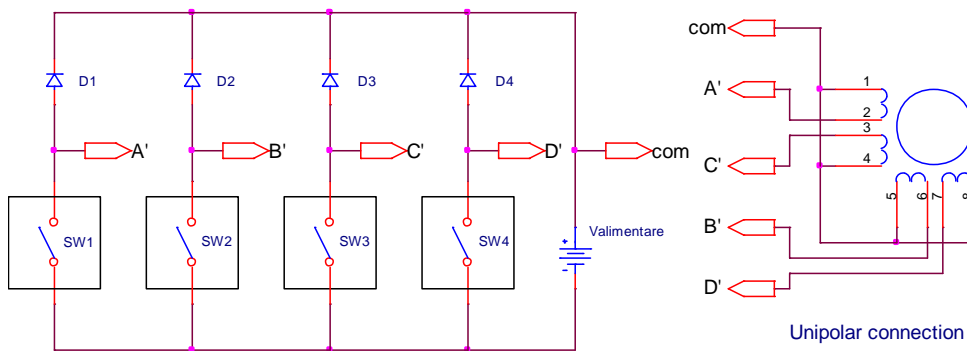

Figure 3. Unipolar connection driver

The states of motor coils and chronograms of current for full step - double command are showed in figure 4, where an exaggerated 45° angle for a full step is for evidence of phenomenon. The usual commercial hybrid motors have 1.8° step angle. Red color for wire suggest the north magnetic pole, blue color suggest the south magnetic pole, and black color suggest an inactivated coil.

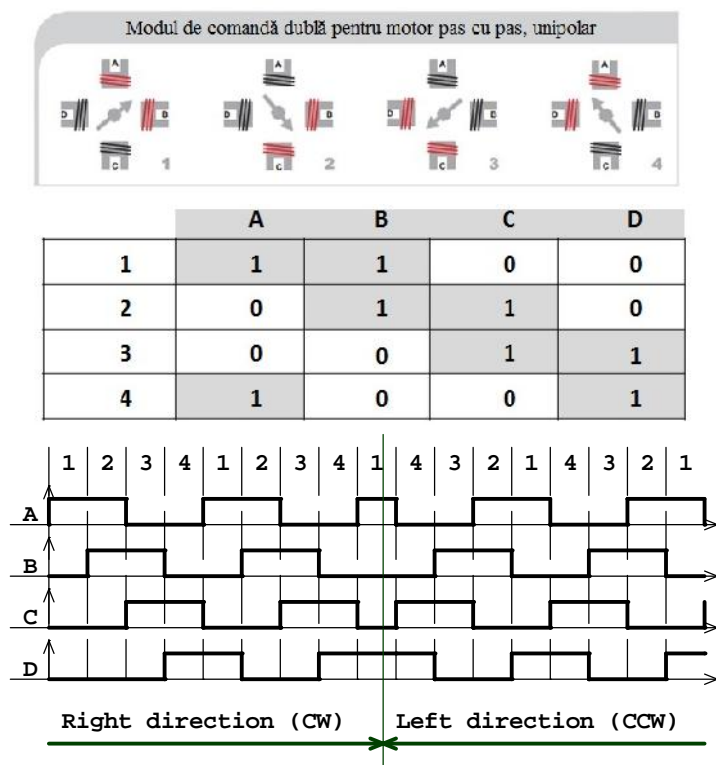

Figure 4. States of motor's coils and current evolution

Electrical parameters of motor coil are: resistance $R=1.1 \Omega$, inductance $L=1.7\text{mH}$, nominal current $I_{\max}=3\text{A}$, and these values were used in the next simulation examples.

A time constant for motor's coils determines a slow increase and decrease of current through the motor's coil. Rise time and fall time are approximately four times constant of motor's coil.

$$\tau = \frac{L}{R} = \frac{1.7 \cdot 10^{-3} \text{H}}{1.1 \Omega} = 1.54 \text{ms}, \quad (1)$$

Rise time and fall time of current through the motor's coil can be reduced by adding an external resistor in series with motor coil and implicitly by using a relatively high value of voltage source. In simulation schemas used in figure 5, a resistor of 2.9Ω was introduced for limiting current at 3A for a voltage source of 12V.

$$\tau = \frac{L}{R + R_{ext}} = \frac{1.7 \cdot 10^{-3} \text{H}}{(1.1 + 2.9) \Omega} = 0.4 \text{ms}, \quad (2)$$

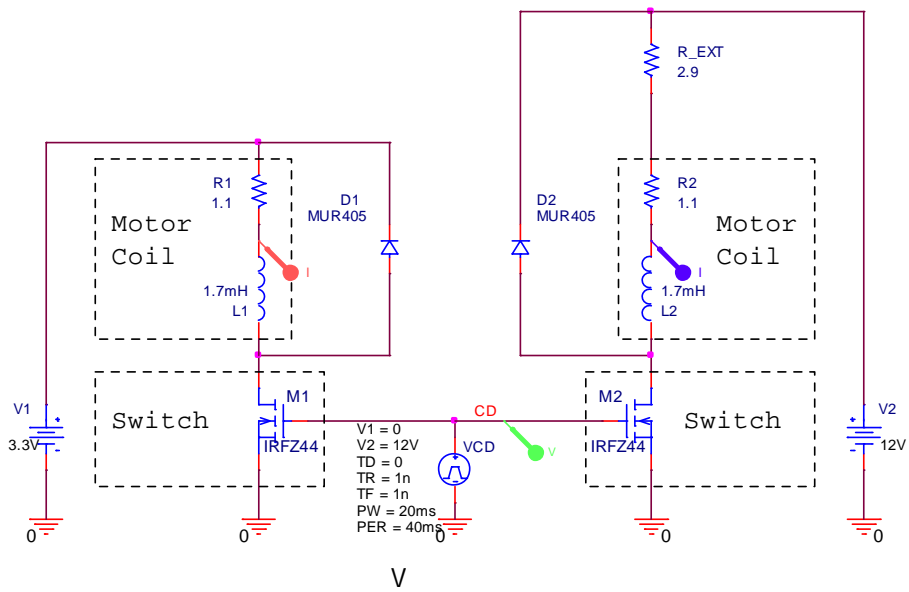

Figure 5. Pspice Simulation Schemas for one motor coil without and with external resistor

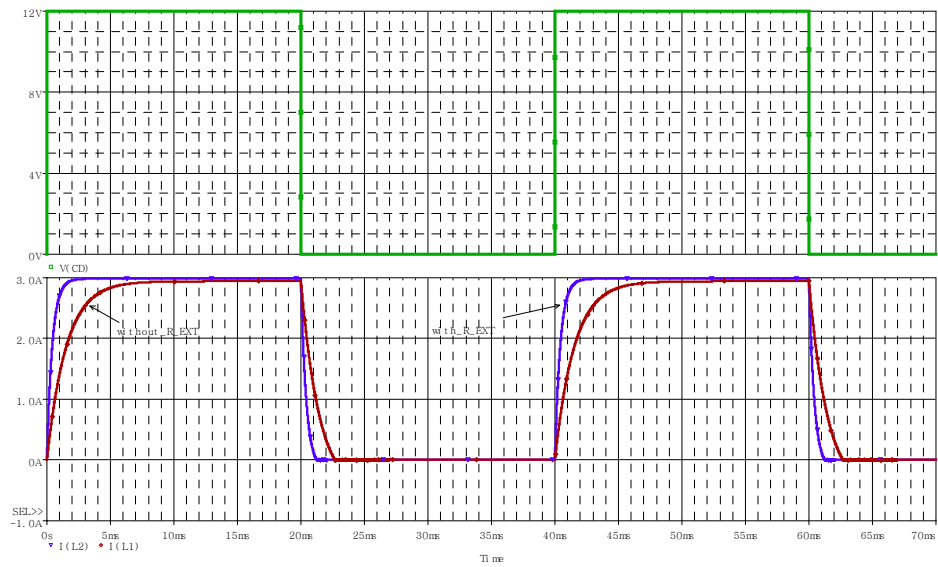

Figure 6. Simulation results for the anterior schemas

For the results of simulation, presented in figure 9, we can observe presence of voltage oscillations on drain terminal for MOSFET in OFF-state and also in common point of coils pair (V(COM1)). A capacitor C1 can reduce these oscillations, but a high value determines an oscillation component on coil's current. Unfortunately the value of voltage source (V_LOW) used for constant current generator must be above of middle of the source used for rapidly decrease of current (V_HIGH). By the way the electrical efficiency is poor.

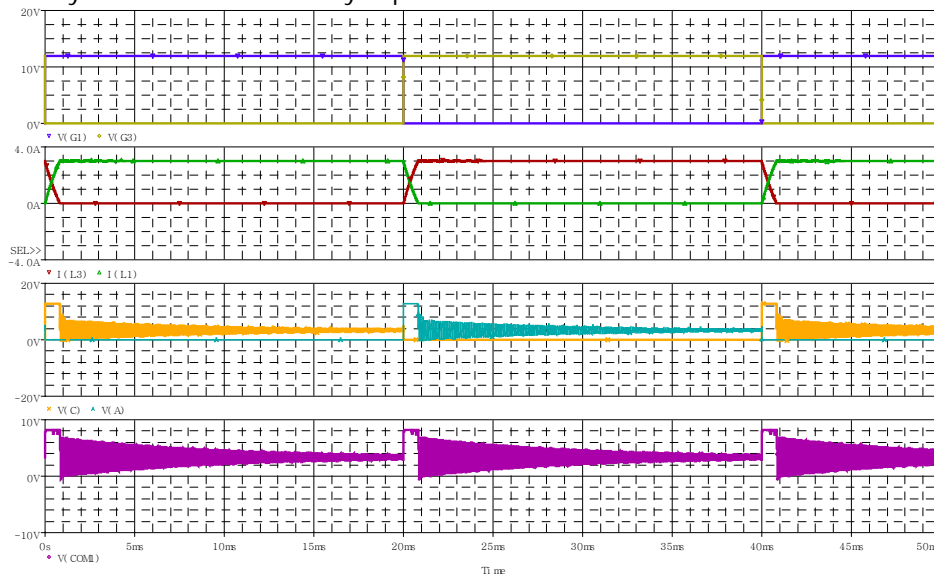

Figure 9. Pspice simulation results for anterior electrical schema

3. Simulations for bipolar stepper motor drivers

Two H-Bridges are necessary for our bipolar stepper motor, one for each motor phase.

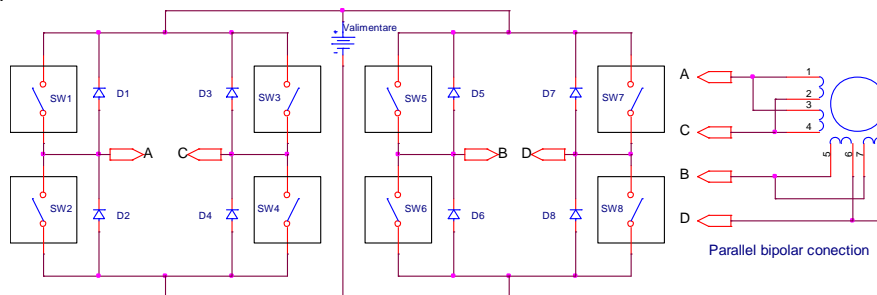

Figure 10. Bipolar connection driver

Parallel connection assures the great couple. The coil's resistance becomes 0.55 and inductance remains 1.7 mH. The bridge connection assures energy recovering when the current decreases. For full step - double command the current flow permanently through the each coils. The limited value for our motor is necessary to be 4 A, not 2x3 amperes. The states of motor coils and current's chronograms are showed in figure 11. Red color for wire suggest the north magnetic pole and blue color suggest the south magnetic pole created by active coils.

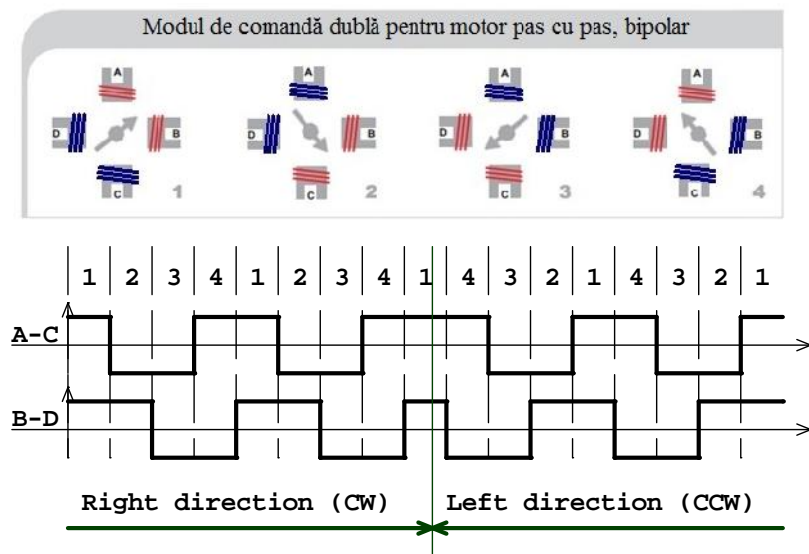

Figure 11. States of motor's coils and current evolution

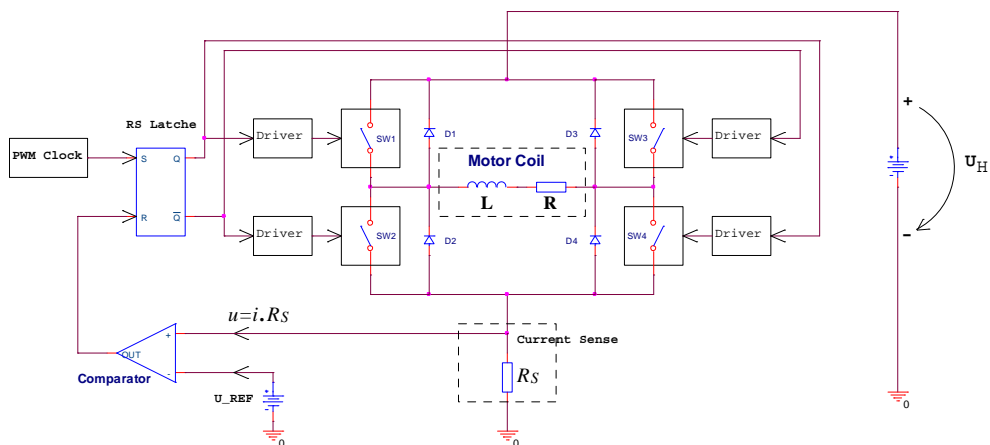

Figure 12. Peak current limiting principia schema for one phase of bipolar motor

In figure 13 we can observe the bipolar parallel configuration of our "eight wires" stepper motor with H-Bridge A and drivers A for one motor's coil and H-Bridge B and drivers B for another motor's coil. Five input-signals are necessary for our module: PAS is the signal for step, active on the rising slope. SENS is the signal for direction of rotation, level "0" for clockwise (CW) direction and level "1" for counterclockwise (CCW) direction. BLOCARE_PUNTE is signal for standby, the current through the motor is cut-off when this signal is on level "0". The two signals REF_A and REF_B, are the voltage references for peak current limiting technique described in figure 12. They are positive constant voltages for full-step double-command. These signals must be correlated with PAS signal when micro-stepping command is used. They can be easily obtained using a microcontroller and two digital to analogue converters (DAC) [3, 4].

For simulation, two phase shifted sinusoidal signal and two precise rectifiers was used (figure 17).

Phases generator block, detailed in figure 14, creates signals for the two phases A and B, based on PAS and SENS signals. For CW direction the phase B is behind the phase A and for CCW direction the phase B is before the phase A.

Peak-current limiting and pulses distribution module, figure 15, assures the complementary inputs signals for each H-bridge's driver.

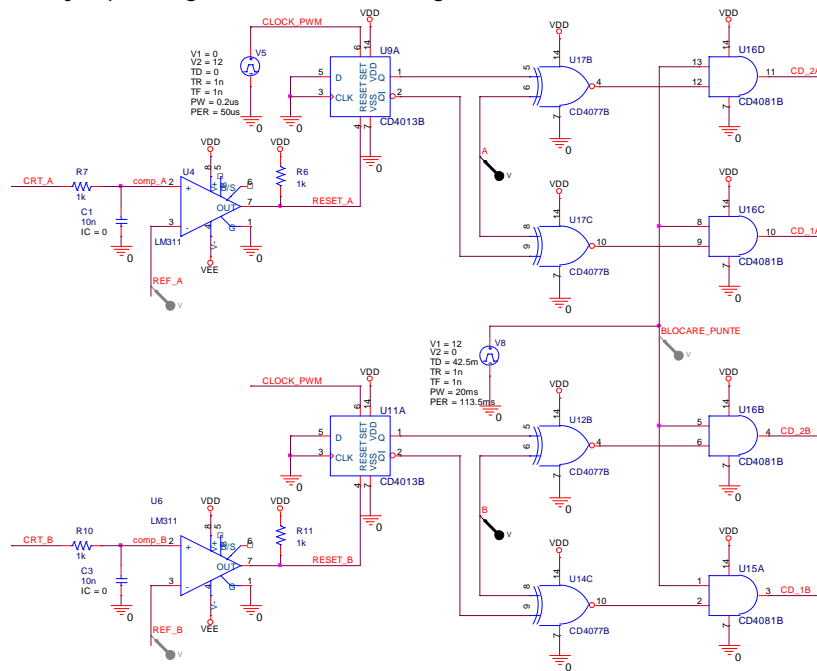

Figure 15. Detailed electrical schema used for simulation of peak-current limiting and pulses distribution module

In simulation example, H-bridges was realized with MOS complementary transistors. This can be an optimal choice if power supply is 12V, digital and analog integrated circuits is biasing by the same power supply, a zero volts level for gate assures "ON" state for P-MOS and "OFF" state for N-MOS. A 12 volts level for gate assures "OFF" state for P-MOS and "ON" state for N-MOS. Bipolar transistors class of B amplifier is a voltage follower and current amplifier and assures rapidly charge and discharge of input capacitor of Power-MOS transistor. For higher current capability, only N-MOS transistors is recommended and adequate drivers based on bootstrap technique. In this case power supply voltage can be higher than 12V.

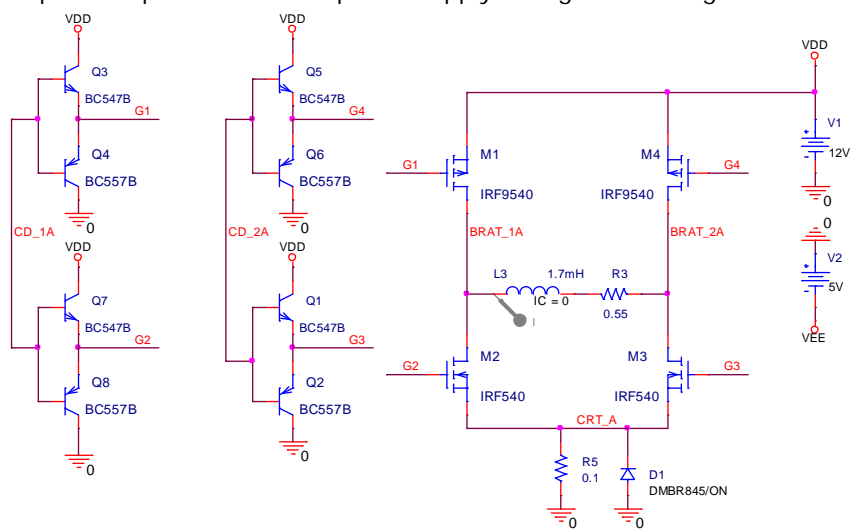

Figure 16. H-Bridge and his drivers used for simulation

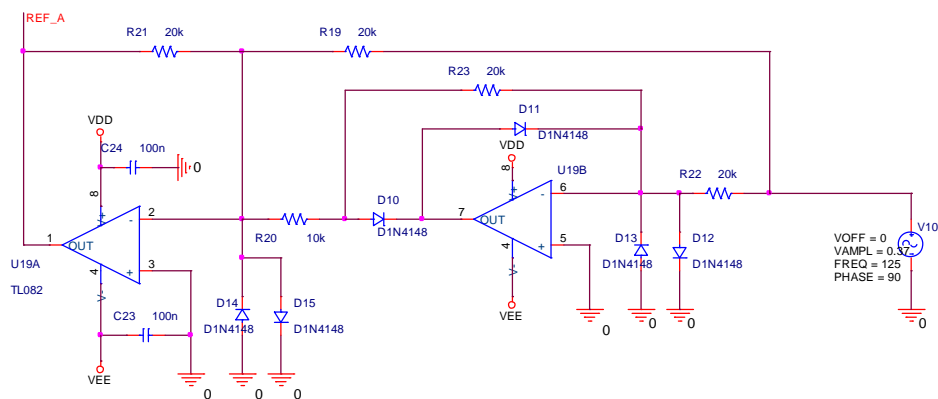

Figure 17. Precise rectifier used for simulation

The results of simulation for conceived electrical schema is presented in figure 18, where we can observe the shifting of phase B behind the phase A for logic level "1" of SENS signal and before for logic level "0". Sinusoidal waves for current trough motor's coils was obtained. Frequency of sinusoidal motor's current is 125 Hz for the simulated example. Period of this wave is 8 ms. Four completely steps is executed during a sinus period. That implies a 2 ms duration for one step. A completely revolution have 200 steps. Therefore a revolution duration is 400 ms. That implies a speed of 150 RPM. For increase the motor speed is necessary to increase frequency of reference voltage signals correlated with step signal. But for high frequency of sinusoidal current the inductive component of motor voltage becomes predominant.

$$\underline{U}_{motor} = \underline{I}_{motor} \cdot (R_{motor} + j\tilde{S}L_{motor}), \quad (3)$$

For a speed of 140 RPM the inductive component of motor voltage is:

$$U = I \cdot 2 \cdot f \cdot f \cdot L = 4 \cdot 2 \cdot f \cdot 120 \cdot 1.7 \cdot 10^{-3} = 5.125V, \quad (4)$$

For 300 RPM, the inductive voltage component becomes 10.25 volts. For higher speed is necessary a higher voltage power supply and preferable N-MOS transistors H-bridges and drivers based on bootstrap technique.

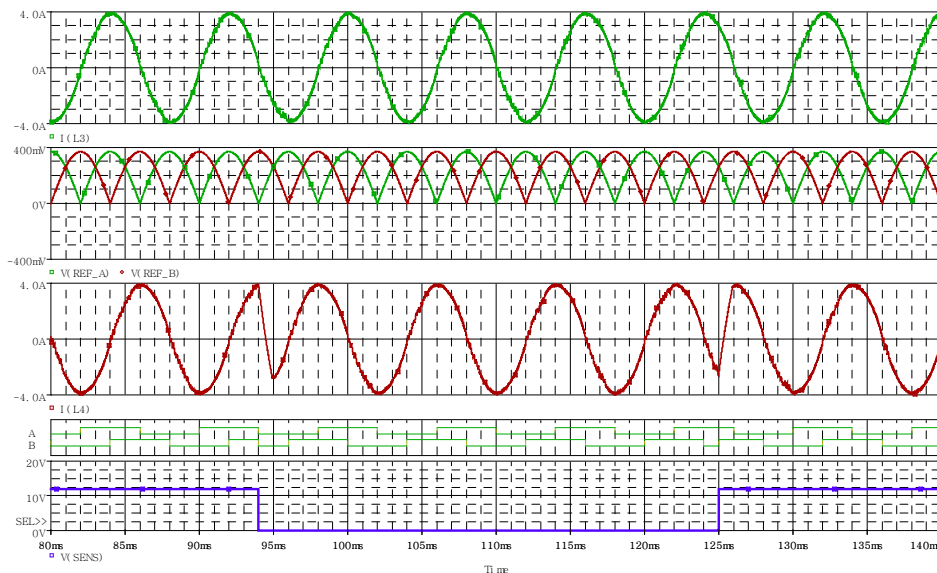

Figure 18. Simulation results for current evolution through the stepper motor's coils for bipolar connection and rectified sinusoidal wave for reference voltage.

4. Conclusion

Using a stepper motor is possible to design applications in simple open-loop control system. Stepper motor has the advantage of producing high torque at low speed. The time-constant of motor coil determines a slow increase and decrease of current through the motor's coil. That limits the maximum speed of motor. For increasing the maximum speed is necessary an external resistor, but electrical efficiency is poor. Using constant current sources the electrical efficiency increase. Linear current sources however have a small electrical efficiency.

Current sources based on chopped technique considerably improving the electrical efficiency. For the small motors drives there are many integrated circuits. For big motors drives are necessary to use discrete power MOS transistors. A complete drive module for bipolar stepper motor was conceived and simulation results confirm their functionality. Also this module permits the control of sinusoidal current through the motor coils.

References

- [1] Acarnley P.P., Stepping motors: a guide to modern theory and practice, 4-th Edition, The Institution of Engineering and Technology, 2002.
- [2] Aranjó B., Soori P.K., Talukder P., Stepper motor drives for robotic applications, Power Engineering and Optimization Conference (PEDCO), 6-7 June, Melaka, Malaysia, 2012, 361-366.
- [3] Baluta G., Microstepping Mode for Stepper Motor Control, International Symposium on Signals, Circuits and Systems, 12-13 July, Iasi, Romania, 2007, Vol. 2, 1-4.
- [4] Baluta G., Coteata M., Precision Microstepping System for Bipolar Stepper Motor Control, International Aegean Conference on Electrical Machines and Power Electronics, 10-12 September, Bodrum, Turkey, 2007, 259-264.
- [5] Toma E., Simion C.M., Bogdan L., Improving of Stepper Motor Behaviors Used on Cinematic Chain of Machine-Tools for Electrical Discharge Machining, Nonconventional Technologies Review, Volume XVII, no. 2, 2013, 97-102.

Address:

- As. Drd. Eng. Emanoil Toma, "Lucian Blaga" University of Sibiu, Str. Emil Cioran, nr. 4, 550024, Sibiu, emanoil.toma@ulbsibiu.ro