



---

## Improved Design of a Portable Balcony Crane

Onyedikachi F. Oti

Department of Mechanical Engineering, Michael Okpara University of Agriculture, Umudike  
P. M. B. 7267, Umuahia

---

**Abstract** Moving heavy and large household loads such as furniture and fridges, in or out of apartments at the upper floors of multiple floor residential buildings is a tedious task, most especially where there is steep and narrow staircase that makes it impossible for one to follow the basic rules of lifting and carrying. A portable balcony crane designed to create an alternative to that long and stressful process, was modified in this project. The modified balcony crane is incorporated with a rotating arm that would enable loads to be directly lifted into or from the balcony, without moving the whole crane. The results of the performance testing of the crane confirmed that a maximum load of 150kg can be lifted safely, using ten 20 Liters plastic buckets of water as counterweight. The crane, which was designed and fabricated with locally available standard materials, would help reduce manual lifting of heavy, large and unbalanced loads in and out of apartments in multi floor residential building. This would in turn reduce the exposure of residents to musculoskeletal diseases and trauma. The total cost of producing one unit of the balcony crane is Sixty-Four thousand, Four Hundred and Sixty Naira (N 64,460:00) only.

**Keywords** Rotary Arm Crane; Household Loads, Counterweights; Multi-Floor Buildings; Musculoskeletal Diseases

---

### 1. Introduction

The current trend in most cities all over the world is the development of multi-floor residential buildings, mainly to overcome the challenges of urban over population and ensure the optimal use of scarce land resources [1]; [2]. Staircase and elevators are required for vertical movement in such buildings, though the use of elevators is recommended for buildings having more than three floors [3]. However, it is obvious that apart from some hotels and corporate buildings in major Nigerian cities, most residential buildings of even more than three floors do not have elevators. Thus, the staircase is the only option through which large and heavy household items like couches, freezer, fridge, foam, wooden cabinets, etc., can be moved in or out of the apartments on the upper floors of such building. Moving these large and heavy loads through the staircase is always stressful, especially in buildings with narrow and steep staircase. This is because, traversing the stairs while carrying large and heavy loads makes it impossible for one to follow the basic rules of lifting and carrying. Improper load lifting and carrying can induce musculoskeletal disorders (MSDs), which are injuries in the body's joints, ligaments, muscles, nerves, tendons, and structures that support limbs, neck and the spine, due to uneven loading of the muscles, joints and nerves. MSDs are degenerative diseases and inflammatory conditions that cause pain and impair normal activities of an individual [4-6].

Perhaps, lifting operations in multi-floor residential buildings could be much easier for an occupant if there is a portable hoisting equipment in place, which can be used lift large and heavy household load in and out of the apartment at the upper floors through the balcony. Though there are several existing models of portable crane like the types reported by [7], which can be used for such lifting operations, but the need to secure these cranes



on a part of the building before they can be used discourages most individuals who may wish to have such equipment, since it may not be possible for them to modify an existing building to accommodate the installation of such equipment. To eliminate the need for securing the hoisting equipment on a structure, [7] developed a portable balcony crane (Fig. 1), which has a maximum load lifting capacity of 136kg using eight 20L plastic buckets of water as counter weight. However, in order to drop or lift a load on or from the balcony floor, the whole crane would have to be moved on its base to properly position the inclined arm before lowering or lifting the load. Though, caster wheels are mounted to the base of this portable balcony crane for mobility, but moving the whole crane with the hoisted load and counter weights is stressful and unsafe. Also, the balcony may not be spacious enough to allow such movement, therefore, to eliminate this stressful activity, this work modified the portable balcony crane developed by [7], to a rotating arm balcony crane, which will encourage the adoption of the equipment in lifting operations among occupants in multi floor residential buildings.

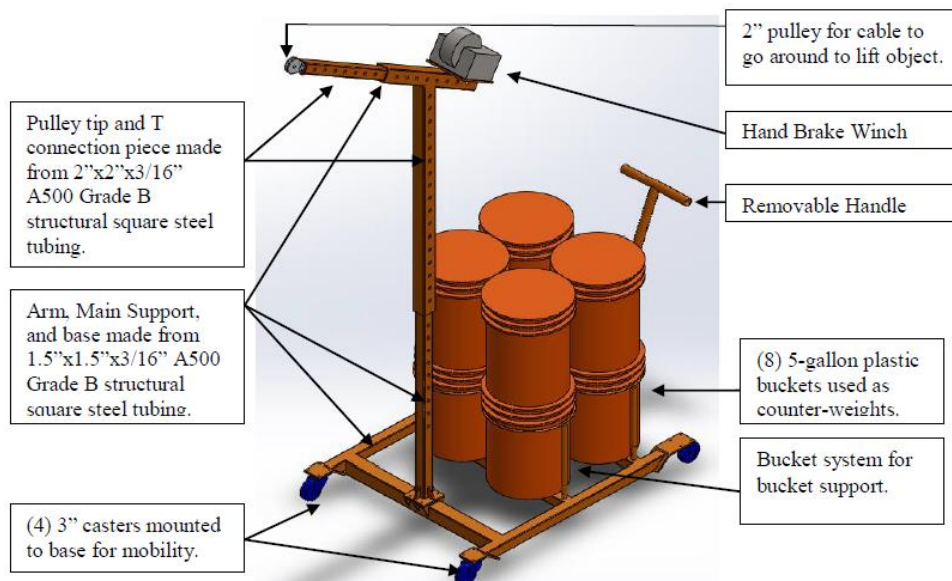

Figure 1: Portable Balcony Crane (Source: [7])

## 2. Design Methodology and Analysis

### 2.1. Design Modification Concept and Considerations

The following concepts and considerations brought about the modification of the existing balcony crane:

- i. The modified balcony crane is designed for buildings not exceeding five floors (about 18 meters). Though, the mass of most household items/appliances like couches, freezer, washing machine, wooden cabinets, foam, etc., is less than 100kg, however, in order to account for the weights of the wire rope, hook and wind effect, the improved machine is designed to lift 140kg load.
- ii. To enable the load bearing arm of the improved balcony crane to be supported and rotated about the main support, the arm is welded to a vertical pipe that functions as a journal bearing at the upper part of the main support.
- iii. To make the fabrication of the balcony crane easy, the main support and the rotating arm were designed to be constructed from standard mild steel pipes, while its base structure will be constructed from mild steel channel section beam sourced locally to encourage mass production of the crane.
- iv. The height and width of a standard balcony in multi floor residential buildings in Nigeria are 2.5m and 1.2m respectively, while the height of the railing is 1.3m. Thus, to ensure that there is enough space to operate and move the crane within the balcony, the total height of the crane is 2.3m, while the length of its base is 1.1m. The winch will be mounted on base positioned at shoulder height (1425mm).
- v. For safe operation of the crane, the manual winch selected for the operation of the improved balcony crane is incorporated with pawl and ratchet mechanism to avoid the free fall of loads during lifting operation, which may be catastrophic.



- vi. The crane has to be strong enough to withstand the forces acting on it without tipping over or failing, but also lightweight for it to be lifted and assembled by two persons (50<sup>th</sup> percentile male). Thus, the components of the crane were designed to be safe, bolted and easily assembled within reasonable time.

## 2.2. Description of the modified balcony crane

The main parts of the portable rotating arm balcony crane (Fig. 2) include the base, counterweight platform, main support, rotating arm, and the winch assembly.

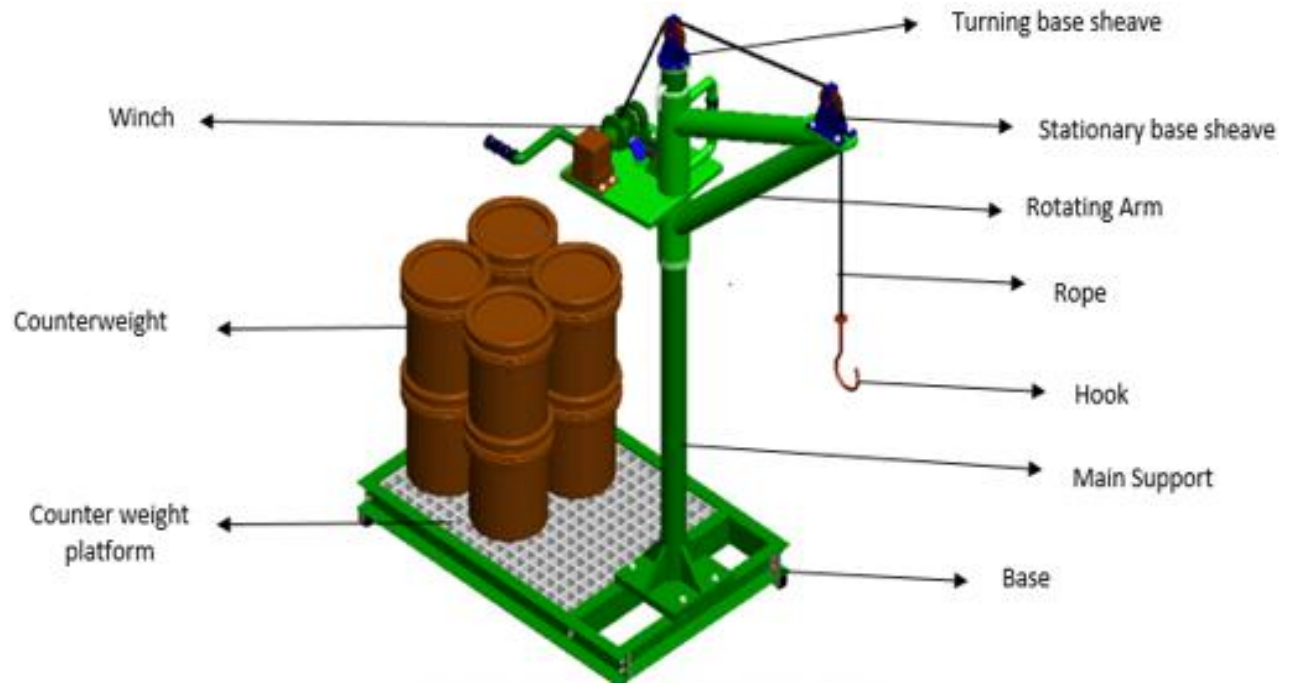

Figure 1: Portable Rotating Arm Balcony Crane

The rectangular base is the main supporting structure upon which every other component of the crane and the required counterweight are supported. It is a bolted section comprising of two long frames and three crosspieces fabricated from C-channel section beam. Between the mid crosspiece and the back crosspiece is a square cavity on which the counterweight platform, fabricated from steel grating is placed. Bolt holes are drilled on the top surface of each of the two front crosspieces through which the main support is bolted to the base. The main support is constructed from a steel pipe, with the lower end welded to an end plate with bolt holes for bolting down the main support to the base structure, while at the upper part of the main support is a journal on which the rotating arm of the crane is supported. A collar is welded below the journal to ensure that the rotating arm do not slide down along the main support, while above the journal, a hole is drilled through the main support, in which a pin is inserted to stop the rotating arm from sliding upwards. The rotating arm comprising of the plain bearing, inclined arm and rib, is a welded section fabricated from two different sizes of pipes. Also, welded to the main support is a platform on which the winch is mounted. The winch assembly comprises of the winch, sheave, rope and hook. One end of the rope is fitted to the hook, on which the load is hanged, while the other end of the rope runs through the sheaves to the hoisting drum of the winch, where it is securely fixed. As the winch is manually cranked, the rope winds round the turning hoisting drum, thereby lifting the load. With the load lifted up to the clearance of the balcony, the rotating arm with the hoist assembly is now swiveled to position the arm to the required position before lowering the hoisted load.

## 2.3. Determination of the Required Counterweight for the Crane.

The free body diagram of the crane is shown in Fig. 3, while the lengths of the structural members of the crane is shown in Fig.4. The lengths of the rib ( $l_1$ ) and the arm ( $l_2$ ) were respectively determined from Equations (1) and (2) as 0.894m and 1.281m, while their angles of inclination ( $\theta_1$ ) and ( $\theta_2$ ) from the horizontal were respectively determined from Equations (3) and (4) as  $26.5^\circ$  and  $51.3^\circ$ . Since the maximum design load ( $m_L$ ), to



be lifted by the crane is 140kg, therefore the rated design load lifting capacity ( $W_L$ ) of the crane was estimated from Equation (5) as 1400N. Thus, considering the angle of inclination ( $\theta_2$ ) of the arm, the stability of the crane is governed by the equilibrium equation given in Equation (6), from which the counterweight ( $W_{CW}$ ) required for the stability of the crane during lifting operation was determined as 2010N. Therefore, neglecting the weights of the empty buckets, the number of 20 Litres plastic buckets required as counterweight for the crane was determined from Equation (8) as 10.24 buckets.

$$l_1 = \sqrt{(x_2)^2 + (y_1 - y_2)^2} \quad (1)$$

$$l_2 = \sqrt{(x_2)^2 + (y_1 - y_3)^2} \quad (2)$$

$$\theta_1 = \tan^{-1} \left( \frac{y_1 - y_2}{x_2} \right) \quad (3)$$

$$\theta_2 = \tan^{-1} \left( \frac{y_1 - y_3}{x_2} \right) \quad (4)$$

$$W_L = m_L \times g \quad (5)$$

$$(W_L \times x_2) \sin(\theta_2) = W_{CW} \times a \left( x_1 - \frac{a}{2} \right) \quad (6)$$

$$a = n_1 \times D_{bucket} \quad (7)$$

$$n_{buckets} = \frac{W_{CW}}{m_w \times g} \quad (8)$$

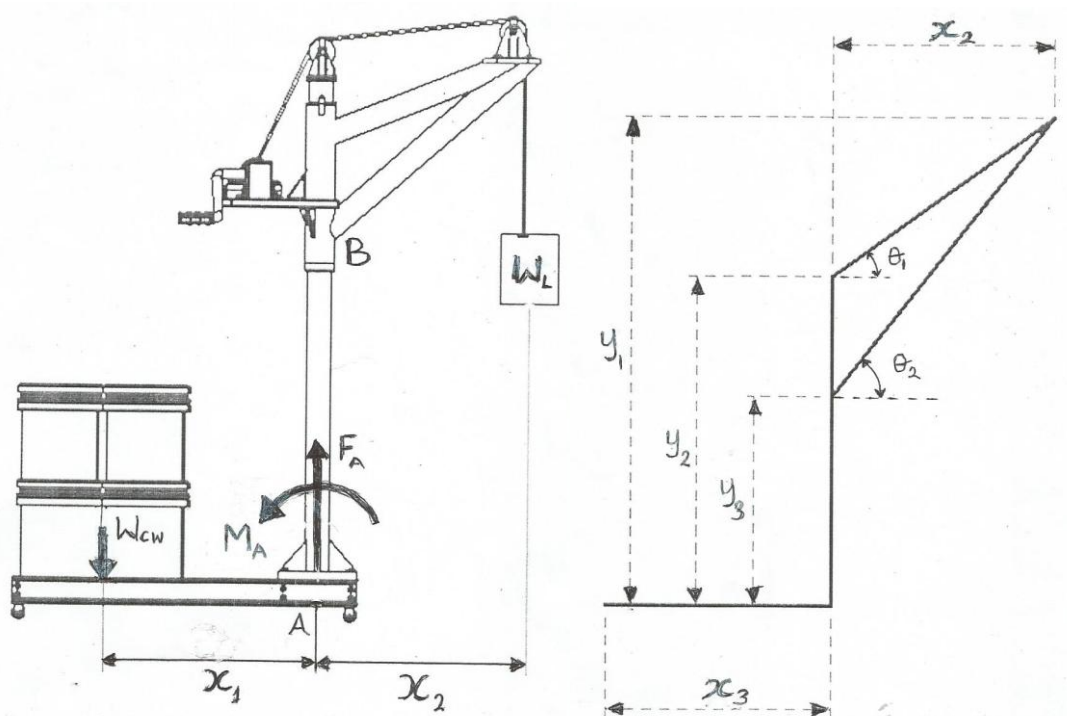

Figure 3: Free Body Diagram of the Crane Figure 4: Dimension of the structural members of the Crane

Where;  $x_1 = 1.0\text{m}$  and  $x_2 = 0.8\text{m}$  are the back-span and swing of the improved balcony crane respectively;  $x_3 = 1.2\text{m}$  is the length of the base structure;  $a$ ,  $n_1 = 2$ , and  $D_{bucket} = 0.32\text{m}$  are the effective length of the counterweight platform, number of buckets along the length of the counterweight platform, and diameter of each bucket respectively;  $m_w$  is the mass of water contained in a 20 litre plastic bucket,  $20\text{ kg}$ ;  $g = 9.81\text{m/s}^2$  is gravitational acceleration.

#### 2.4. Selection of Materials for the Main Support and Rotating Arm of the Crane.

During lifting operation, as the load ( $W_L$ ) is lifted from the ground as shown in Figure 2, the rotating arm is subjected to bending stress only, which will be maximum at point B, while the main support is subjected to combined tensile and bending stresses, which will be maximum at point A. Since the material for the main support and rotating arm is mild steel, and both component are likely to be subjected to uncertain stresses, thus, using a factor of safety ( $FS_1$ ) of 4 as recommended by [8], the design load ( $W_{Ld}$ ) for the main support and



rotating arm was determined from Equation (9) as 5886 N. Consequently, the bending moment ( $M_A$ ) at point A of the main support and bending moment ( $M_B$ ) at point B of the rotating arm were respectively determined from Equations (10) and (11) as 4480 Nm and 3482 Nm. Thus, considering the effect of shock and fatigue loads, the design bending moments on the main support ( $M_1$ ) and rotating arm ( $M_2$ ) were determined from Equations (12) and (13) as 6270 Nm and 5223 Nm. Consequently, the section moduli ( $Z_1$ ) and ( $Z_2$ ) of the pipes required for fabricating the main support and rotating arm were respectively determined from Equations (14) and (15) as  $57 \times 10^3 \text{ mm}^3$  and  $47.5 \times 10^3 \text{ mm}^3$ . From standard mild steel pipes property table [9], the tabulated section modulus closer to the calculated value for the main support is  $65.8 \times 10^3 \text{ mm}^3$ , corresponding to a standard pipe with outer diameter and wall thickness of 101.6 mm and 8.0 mm, respectively. While, the tabulated section modulus closer to the calculated value for the rotating arm is  $47.6 \times 10^3 \text{ mm}^3$ , corresponding to a standard pipe with outer diameter and wall thickness of 88.9 mm and 7.6 mm, respectively. Hence, these standard pipes were used in fabricating the main support and rotating arm. To enable the arm to be rotated on the main support whose outer diameter is 101.6 mm, a standard pipe with inner and outer diameters of 102.3 mm and 114.3 mm, respectively, was selected as the pipe for the plain bearing of the rotating arm. Since the plain bearing is vertically supported on the main support, it will be subjected to a maximum bending moment equal to that of the main support, and thus, the section modulus of the material must be equal or greater than the calculated value of section modulus for the main support. From [9], the tabulated value of the section modulus of the pipe selected for the plain bearing is  $66.2 \times 10^3 \text{ mm}^3$ , which is higher than the calculated value of  $57 \times 10^3 \text{ mm}^3$ , therefore, the selected pipe is safe.

$$W_{Ld} = W_L \times FS_1 \quad (9)$$

$$M_A = W_{Ld} \times x_1 \quad (10)$$

$$M_B = W_{Ld} \sin \theta_2 \times x_1 \quad (11)$$

$$M_1 = k_b \times M_A \quad (12)$$

$$M_2 = k_b \times M_B \quad (13)$$

$$Z_1 = \frac{M_1}{\sigma_b} \quad (14)$$

$$Z_2 = \frac{M_2}{\sigma_b} \quad (15)$$

Where;  $k_b$  (1.5) is the shock and fatigue factor for steady loads;  $\sigma_b$  (110 MPa) is allowable bending stress for mild steel [8].

## 2.5. Selection of Materials for the Structural Members of the Crane Base

The “through bolt” method of bolting will be used in coupling the structural members of the crane base and in bolting down the main support of the crane to the base. Thus, there will be need for easy access to the bolts and nuts during assembly and dis-assembly of the portable crane. Hence, a channel section beam was considered for the fabrication of the structural members of the base of the improved balcony crane. Since the load on the main support is equally shared by the two front crosspieces of the base on which the main support is bolted down on, thus, the various loads acting on each of the front crosspiece are depicted in the free body diagram (Fig. 5). The direct load ( $F_A$ ) at point A on each crosspiece was determined from Equation (16) as 2800 N, while the moment at point A on each crosspiece is equal to  $M_A$  (4480 Nm). *Beamboy* software was used to analyse the effects of these loads on the crosspiece. The result of the analysis (Fig. 6) shows that the maximum shear force ( $F_{A1}$ ) on the bolt used for bolting the crosspiece to the side frame of the base structure is 7370 N, while the maximum bending moment ( $M_{A1}$ ) on the crosspiece is 2760 Nm. Considering the effect of shock and fatigue loads, the design bending moments ( $M_3$ ) on each of the crosspiece was determined from Equation (17) as 4140 Nm. Thus, the section modulus ( $Z_3$ ) required for the material of the crosspiece was determined from Equation (18) as  $16.8 \times 10^3 \text{ mm}^3$ . However, due to its availability confirmed from market survey, the “C100 × 10.8” type of channel section beam, which has a section modulus of  $37.5 \times 10^3 \text{ mm}^3$  and  $5.74 \times 10^3 \text{ mm}^3$  along its  $X - X$  and  $Y - Y$  axis respectively [10], was selected as the material for the structural members of the base. Since the section modulus ( $Z_3$ ) required for the crosspiece material is greater than the section modulus of the selected material along its  $Y - Y$ , but less than its section modulus along the  $X - X$  axis, therefore, the channel section





beam for the crosspiece will be bolted on the side frame in a way that the direct load ( $F_A$ ) at point A of the crosspiece will act along the  $X - X$  axis of channel section beam.

$$F_A = \frac{W_{Ld}}{2} \tag{16}$$

$$M_3 = k_b \times M_{A1} \tag{17}$$

$$Z_3 = \frac{M_3}{\sigma_{ys}} \tag{18}$$

Where;  $\sigma_{ys} = 247 \text{ MPa}$  is the yield stress of mild steel.

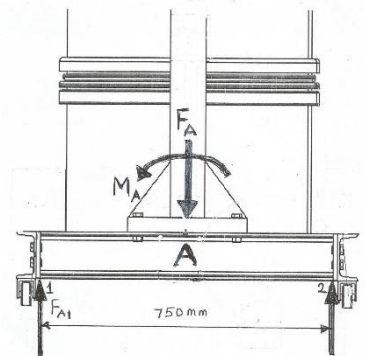

Figure 5: FBD of each front Crosspiece

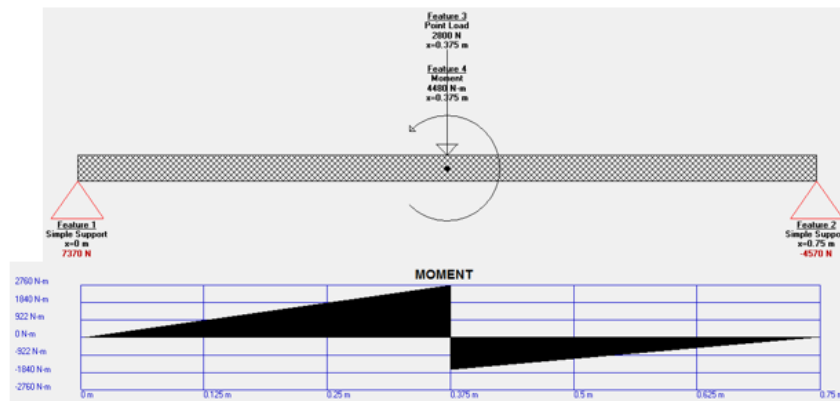

Figure 6: Force Analysis and Bending Moment of the cross piece

Similarly, Fig. 7 shows the free body diagram of the side frame for the base structure of the crane. The load ( $F_{A2}$ ) at point C and D of each side frame of the base was determined from Equation (19) as 1842.5 N, while the load at point E is due to the counterweight ( $W_{CW} = 2010 \text{ N}$ ). *Beamboy* software was also used to analyze the effect of these loads on the side frame of the base structure and the caster wheels fixed under the frame. The results (Fig. 8) of this analysis shows that the maximum load ( $R_C$ ) on each of the front caster wheel placed under the side frames is 3840N, while the maximum load ( $R_F$ ) on each of the rear wheels is 1850N. Fig. 8 also, shows that the maximum bending moment ( $M_C$ ) on each side frame is 685 Nm, and considering the effect of shock and fatigue loads, the design bending moment on the side frame ( $M_4$ ) was determined from Equation (20) as 1027.5Nm. Thus, the section modulus ( $Z_4$ ) required for the material of the side frame of the crane base was determined from Equation (21) as  $4.16 \times 10^3 \text{ mm}^3$ . which is less than the section modulus of the “C100 × 10.8” type of channel section beam selected for the fabrication of the base, both along its  $Y - Y$  and  $X - X$  axis. However, to enable the caster wheels to be bolted properly due to the dimension of its base plate, the channel section beam for the side frame will be coupled to the crosspiece in a way that the load ( $F_{A2}$ ) at point C and D of the side frame will act along the  $X - X$  axis of channel section beam.

$$F_{A2} = \frac{F_{A1}}{2} \tag{19}$$

$$M_4 = k_b \times M_C \tag{20}$$

$$Z_4 = \frac{M_4}{\sigma_{ys}} \tag{21}$$

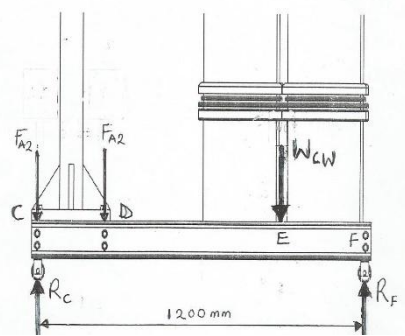

Figure 7: FBD of the Side Frames

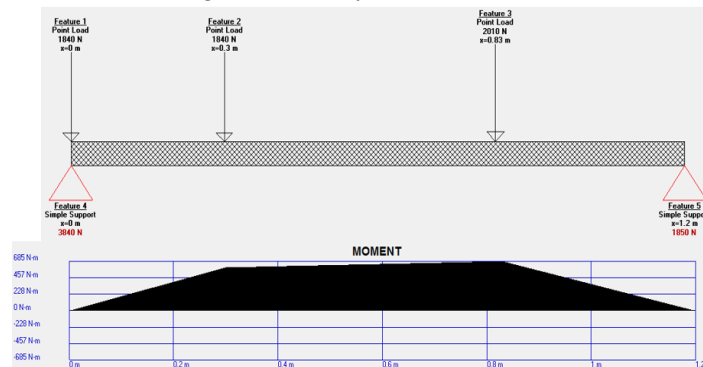

Figure 8: Force Analysis and Bending Moment of the cross piece

## 2.6. Selection of Hoisting Rope, Sheave and Winch for the Crane

Among all the fibrous ropes used in hoisting applications, nylon rope is most preferred, because it has superior strength and remarkable stretching capabilities, and also allows a smaller size of rope to be used. Due to its availability and size, a 16 mm diameter nylon rope (8 strand) was selected as the hoisting rope for the crane because the factor of safety ( $FS_r$ ) and the safe load ( $F_r$ ) for the size of nylon rope selected is 12 and 3.30kN respectively [11] which exceeds the maximum load lifting capacity of the crane (1.4kN). Thus, the maximum safe mass ( $m_r$ ) for the selected rope was determined from Equation (22) as 336.40kg, which is two times greater than the rated load (140kg) of the portable crane, hence the selected rope is safe for the operation of the crane. Since nylon ropes are elastic and abrasion resistant, they can run on smaller sheaves compared to other fibrous ropes. Thus, the minimum pitch diameter ( $PD_s$ ) of the sheave selected for the rope is 150 mm. According to [8], the best groove angle which provides greatest adhesion without slipping, prevents undue wedging and offers least resistance to the rope while leaving the groove is  $45^\circ$ , therefore the groove depth ( $G_d$ ), from the centre of the rope, radius of the groove ( $G_r$ ) at the bottom of the sheave, and groove width ( $G_w$ ) of the sheave were determined from Equations (23), (24) and (25) as 16 mm, 4.0 mm and 17.33 mm, respectively [8]. For increased pressure velocity and load bearing capacity, a straight walled sheave with roller bearing was considered [12], thus, the minimum thickness ( $t_s$ ) and outer diameter ( $OD_s$ ) of the required sheave were respectively determined as 58 mm and 182 mm using the relations in Equations (26) and (27). Furthermore, the diameter ( $d_s$ ) of the shaft on which the sheave is mounted was determined as 23.15mm, using the maximum stress relation given by [13]; [14]; [8] in Equation (28). Therefore, a standard 25 mm diameter shaft will be required for the sheave, consequently, a standard roller bearing sheave for 16 mm rope, with outer diameter  $OD_{s1}$ , bearing bore ( $d_{s1}$ ), and sheave thickness ( $t_{s1}$ ) of 203mm, 25.4mm and 60 mm [15], was selected for the operation of the crane. The maximum pressure ( $P_{sb}$ ) on the bearing of the sheave was calculated as  $0.94 \text{ N/mm}^2$ , using the relation in Equation (31) given by [8]. Since this pressure did not exceed the maximum  $6.0 \text{ N/mm}^2$  recommended for the lowest peripheral speed in manual hoists, therefore the selected sheave is satisfactory for the operation of the crane.

$$m_r = \frac{F_r}{g} \quad (22)$$



$$G_d = d_r \quad (23)$$

$$G_r = 0.25d_r \quad (24)$$

$$G_w = d_r + \frac{d_r}{12} \quad (25)$$

$$t_s = 0.25 + 3.59d_r \quad (26)$$

$$OD_s = PD_s + 2d_r \quad (27)$$

$$d_s = \left[ \frac{16}{\pi \tau_2} (\sqrt{(M_s)^2 + (T_s)^2}) \right]^{\frac{1}{3}} \quad (28)$$

$$M_s = (W_L + W_r) \times \frac{t_s}{2} \quad (29)$$

$$T_s = (W_L + W_r) \times \left( \frac{PD_s}{2} \right) \quad (30)$$

$$P_{sb} = \frac{(W_L + W_r)}{t_{s1} \times d_{s1}} \quad (31)$$

$$W_r = w_{r1} \times H \quad (32)$$

Where;  $w_{r1} = 0.147kg/m$ , is the weight of the nylon rope per unit length (engineeringtoolbox.com, 2017);  $H = 20m$  is the total length of the nylon rope;  $\tau_2 = 55Mpa$ , is the permissible shear stress for a shaft without key way [8].

Also, it is obvious that apart from lifting and lowering of loads, the hoist should be able to pull the loaded nylon rope between the grooves of the fixed and rotating sheaves. Thus, a hand crank winch suitable for lifting, lowering and pulling within the rated capacity, with a self actuating brake mechanism, that ensures the suspension of loads and 'jerk-free' movement of the rope when lowering a load under pressure, was considered for the operation of the crane. The length of the crank handle ( $L_{ch}$ ) and diameter of the winch drum ( $d_{wd}$ ) that can accommodate the total length of fiber rope required for the operation of the crane are 250 mm and 100 mm [16]. Thus, the number of revolutions ( $N_{wd}$ ) made by the winch drum to raise the load from the ground floor to the balcony of the last floor of a five story building and the ideal velocity ratio ( $VR_1$ ) of the required winch were respectively determined from Equations (33) and (34) as 180 and 15.7:1. Consequently, the effort ( $P$ ) required on the crank handle to lift the load was determined as 90.96N, using the relations in Equation (35) given by [17]. However, a standard hand crank winch (spur gear type), Model LBW650NC [16] with gear ratio ( $VR_2$ ), rated load lifting capacity, and maximum cable capacity of 15:1, 7357 N, and 22mm respectively, was selected for the operation of the crane.

$$N_{wd} = \frac{L_d}{d_{wd}} \quad (33)$$

$$VR_1 = \frac{2\pi L_{ch} N_{wd}}{L_d} \quad (34)$$

$$P = \frac{(W_L + W_r)}{VR_1} \quad (35)$$

Where;  $L_d = 18m$ , is the load distance (equivalent to the height of a standard 5-storey building).

## 2.7. Selection of Bolts and base plates

Figure 8 shows the base plate with bolt holes, through which the main support is bolted down to the base structure of the crane. According to [14], the direct load ( $w_{t1}$ ) carried by each bolt and the load ( $w_1$ ) in a bolt per unit distance were respectively determined from Equations (36) and (37) as 1400N and 52.7N/mm. Since the heavily loaded bolt is at a distance,  $L_2$  from the tilting edge of the base plate, therefore the load ( $w_{t2}$ ) on the heavily loaded bolt was determined from Equation (38) as 10541.18N. Thus, the maximum tensile load ( $w_t$ ) on the heavily loaded bolt was determined as 11941.18 N using the relation in Equation (39). Mild steel coarse series bolts were used for the bolting, therefore, with a factor of safety ( $FS_b$ ) of 5 for the bolts [14], the core diameter ( $d_{c1}$ ) of the bolts was estimated from Equation (40) as 19.898mm. From the standard bolt table (coarse series) in [14], the standard core diameter of the bolt is 20.320 mm and the corresponding size of bolt selected for bolting down the main support to the base structure of the crane is M24. As shown in Figure 5, the bolts used in coupling the crosspiece to the frame of the base is subjected to a maximum shear force ( $F_{A1}$ ), which is equal to 7370 N. Thus, using Equation (41), the core diameter ( $d_{c2}$ ) of the bolts was determined as 15.632. Similarly, from standard table for coarse series, the standard core diameter of the bolt is 16.933 mm and the corresponding size of bolt selected for coupling the crosspiece to the side frame of the base structure of the crane is M20.





$$w_{t1} = \frac{W_{Ld}}{n_1} \quad (36)$$

$$w_1 = \frac{M_A}{2[(L_1)^2 + (L_2)^2]} \quad (37)$$

$$w_{t2} = w_1 \times L_2 \quad (38)$$

$$w_t = w_{t1} + w_{t2} \quad (39)$$

$$d_{c1} = \sqrt{\frac{w_t}{\frac{\pi}{4} \times \frac{\sigma_{tb}}{FS_b}}} \quad (40)$$

$$d_{c2} = \sqrt{\frac{F_{A1}}{\frac{\pi}{4} \times \frac{\sigma_{tb}}{FS_b}}} \quad (41)$$

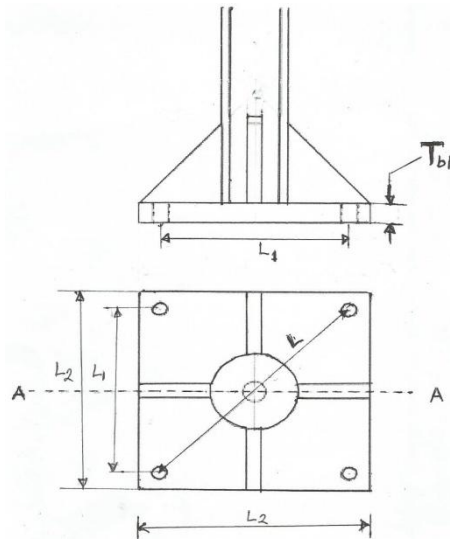

Figure 8: Diagram of the Base Plate for Bolting the Main Support

Where;  $n_1 = 4$ , is the number of bolts on the base plate;  $L_1 = 50$  mm;  $L_2 = 200$ ;  $\sigma_{tb} = 192$  N/mm<sup>2</sup>, is the allowable tensile stress of grade 4.6 mild steel bolts [18].

The force trying to separate the base plate of the main support from the crosspiece is resisted by four bolts, and this force is equal to the direct load ( $w_{t1} = 1400$  N) carried by each bolt (Equation 35). The bending moment ( $M_{p1}$ ) due to the force in two bolts was calculated from Equation (42) as 350kN-mm. Mean radius ( $r_m$ ) of the arc from section A-A over which the load due to tensile force on the main support may be taken to be concentrated was determined from Equation (43) as 50.8 mm, and the centroid ( $\bar{x}$ ) of this arc from A-A was calculated as 32.34 mm, using the relation in Equation (44), given by [14]. Thus, the bending moment ( $M_{p2}$ ) due to the tensile load on the main support was estimated from Equation (45) as 90.552kN-mm. Since the bending moments  $M_{p1}$  and  $M_{p2}$  are in opposite direction, therefore net resultant moment ( $M_p$ ) on the base plate about section A-A was determined from the relation in Equation (46) as 119.45kN-mm. The width ( $b$ ) of the base plate at section A-A was determined from Equations (47) as 259.45kN-mm. Thus, the minimum thickness ( $t_{bp}$ ) of the base plate was estimated as 14.60mm, using the relation given by [14] in Equation (48). Therefore, a standard 15 mm thick mild steel plate was used in fabricating the base plate of the main support and the base on which the winch is mounted.

$$M_{p1} = 2w_{t1} \times \frac{L_3}{2} \quad (42)$$

$$r_m = \frac{D_1}{2} \quad (43)$$

$$\bar{x} = 0.6366r_m \quad (44)$$

$$M_{p2} = 2w_{t1} \times \bar{x} \quad (45)$$

$$M_p = M_{p1} - M_{p2} \quad (46)$$

$$b = L_3 - D_1 \quad (47)$$



$$t_{bp} = \sqrt{\frac{M_p}{\frac{\pi}{6} \times b \times \frac{\sigma_{yt}}{FS_b}}} \quad (48)$$

Where;  $D_1 = 101.6$  mm, is the outer diameter of the pipe for the main support;

Furthermore, the free body diagram of the hoisting drum of the winch assembly is shown in Figure 9. Since the drum shaft is simply supported on its bearing, therefore, taking moments about B, the force ( $F_A$ ) parallel to the wire rope on bearing A was determined from Equation (49) as 3136 N, while the angle of inclination ( $\theta$ ) of the wire rope was determined from Equation (50) as  $25^\circ$ . Thus, the vertical ( $F_{AV}$ ) and the horizontal ( $F_{AH}$ ) components of the force ( $F_A$ ), were determined from Equations (51) and (52) as 2842.20 N and 1325.33 N. Due to the load  $F_{AV}$ , bolts at bracket A will be in direct tension only, thus, the tensile load ( $F_{AV1}$ ) per bolt was estimated from Equation (53) as 1421.10 N. The load  $F_{AH}$  will cause both tension and direct shear on the bolts. The tensile load ( $w_2$ ) in a bolt per unit distance caused by  $F_{AH}$  was determined from Equations (54) as 6.36 N/mm, therefore, the tensile load ( $w_{t3}$ ) on the heavily loaded bolt was determined from Equation (55) as 1113.30 N. Thus, the total maximum tensile load ( $w_{th}$ ) on each bolt was estimated from Equation (56) as 2534.40 N. The direct shear load ( $w_{s2}$ ) caused by  $F_{AH}$  was determined from Equations (57) as 1267.18 N. Combining the tensile and shear loads, the equivalent tensile load  $F_e$  on each bolt was calculated as 3059.30 N, using Equation (58). While, the core diameter ( $d_{c2}$ ) of the bolts was estimated from Equation (59) as 10.072mm, thus, from standard table for coarse series, the core diameter of the bolt is 11.546 mm and the corresponding size of bolt selected for bolting down the winch of the crane is M14 bolts.

$$F_A = \frac{W_{Ld} \times l_4}{l_5} \quad (49)$$

$$\theta = 90 - \left[ \tan^{-1} \left( \frac{y}{x} \right) \right] \quad (50)$$

$$F_{AV} = F_A \cos \theta \quad (51)$$

$$F_{AH} = F_A \sin \theta \quad (52)$$

$$F_{AV1} = \frac{F_{AV}}{n_3} \quad (53)$$

$$w_2 = \frac{F_{AH} \times h_1}{[(l_8)^2 + (L_9)^2]} \quad (54)$$

$$w_{t3} = w_2 \times L_9 \quad (55)$$

$$w_{th} = F_{AV1} + w_{t3} \quad (56)$$

$$w_{s2} = \frac{w_{th}}{n_3} \quad (57)$$

$$F_e = \frac{1}{2} \left[ w_{th} + \sqrt{(w_{th})^2 + 4(w_{s2})^2} \right] \quad (58)$$

$$d_{c2} = \sqrt{\frac{F_e}{\frac{\pi}{4} \times \frac{\sigma_{yt}}{FS_b}}} \quad (59)$$

Where;  $n_3$  (2), is the number of bolts on each side of the winch bracket;  $x$  (300 mm) is the horizontal distance from the main support to the centre of the hoisting drum shaft;  $y$  (640 mm) is the vertical distance from the turning sheave to the hoisting drum shaft;  $L_4 = 140$ mm;  $L_5 = 250$ mm;  $L_6 = 200$ mm;  $L_7 = 150$ mm;  $h_1 = 150$ mm;  $L_8 = \frac{L_6 - L_7}{2}$ ;  $l_9 = L_7 + L_8$

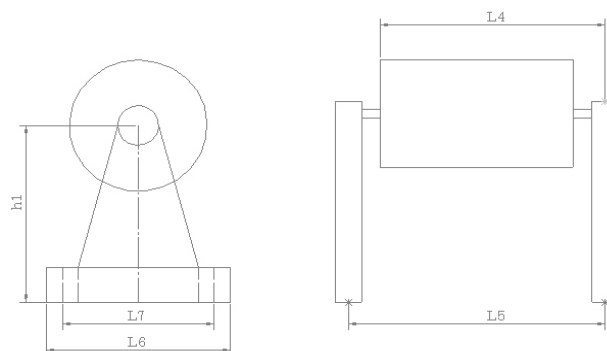

Figure 9: Free Body Diagram of the Hoisting Drum of the Winch



### 2.8. Performance Evaluation Procedure

The modified balcony crane was evaluated after its fabrication to determine the time taken and effort required to lift varying household loads. In evaluating the crane performance, the standard procedure for testing and examining lifting appliances as recommended by [19] was followed whereby the counter weight was kept constant at ten 20L plastic buckets of water. The load was varied from 50kg to 150kg and to get uniform load capacity, bags of rice weighing 50kg each was used in testing the machine. The time taken to carry the bags of rice to the fifth floor of the residential building was taken using a stop watch and the time taken to lift the same bags of rice was also recorded. In order to determine the effort expended in lifting the load using the portable crane, the load was varied from 200N to 1400N and the effort required to lift the load was computed using Equation (60).

$$P_{actual} = \frac{(W_L + W_r)}{\eta_t \times VR_2} \quad (60)$$

Where;  $\eta_t$  (= 75%,) is the transfer efficiency of spur gear type of winch [16].

### 3. Results and Discussion

Performance of the portable hoisting crane as compared to manual lifting of household load is shown in Figure 10. It is shown that 62.5% of time saved in using the improved portable balcony crane for load lifting compared to manual lifting of the loads using the staircase. For 150kg load (equivalent of 3 bags of rice), the occupant had to walk through the staircase at least thrice to move the loads to the upper floors of the building.

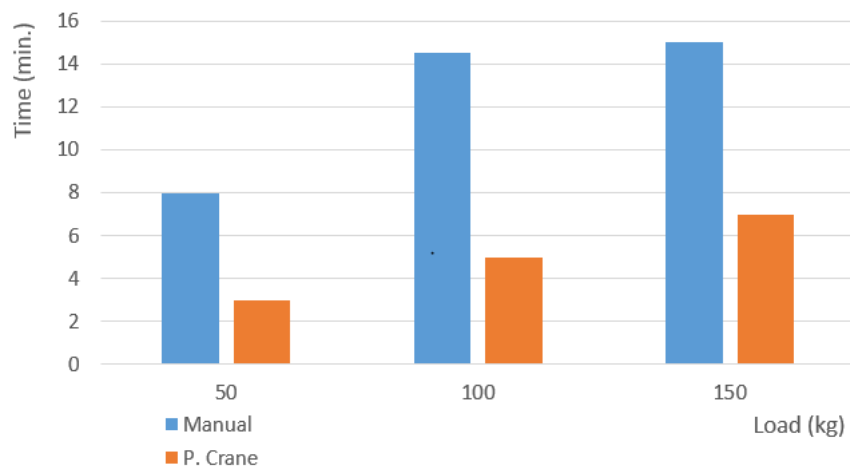

Figure 10: Lifting time for Loads

Figure 11 is the graph for both the ideal and actual effort applied against the lifted loads. It is evident that the effort progress linearly with the load and the actual mechanical advantage obtained from the graph is 11.02. This shows that the portable crane lifts loads that are eleven times heavier than the required effort.

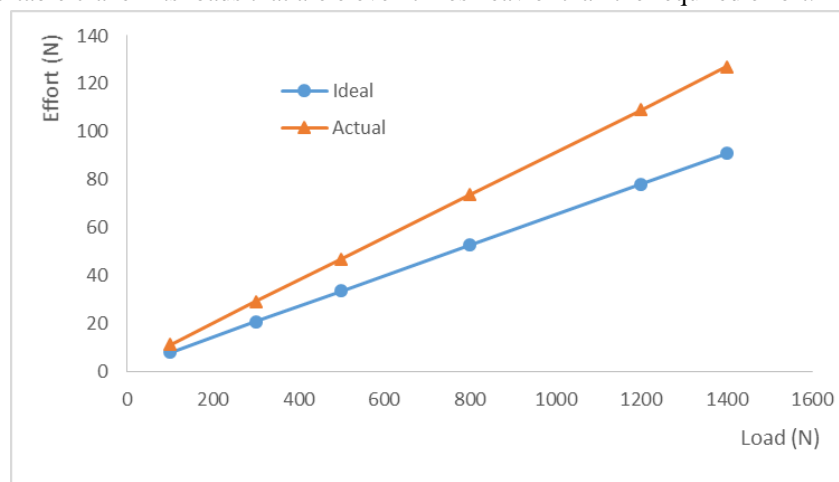

Figure 11: Mechanical Advantage of the Crane



#### 4. Conclusion

A portable rotating arm balcony crane for lifting large and heavy household items in or out of apartments on the upper floors of multi floor residential buildings was developed in this study. The results of the performance testing of the crane confirmed that a maximum load of 150kg can be lifted safely, using ten 20 liters plastic buckets of water as counterweight. The use of this portable hoisting equipment will reduce the manual lifting of heavy and large household items/loads like furniture, fridges, through narrow staircase whose ripple effect would in turn reduce damage to these items and musculoskeletal related diseases. Due to its low cost, easy installation, operation and maintenance, this portable balcony crane is recommended to commercial homeowners and their tenants. The crane can also be used in building construction sites to handle loads that are not safe to be lifted manually.

#### References

1. Aliyu, A. A., Hussaini, A. F., Abubakar, M. Baba, G, B, Mu'ayuwa, M. A (2015). Problems Associated with Elevators in High-Rise Commercial Buildings in North-Western State Capitals of Nigeria. *Journal of Energy Technologies and Policy*. Vol.5, No.12, pg. 62-69.
2. Streen R. (2002), *Urban Policy in Africa: A Political Analysis*, *African Studies Review*, 15(3), Pp. 234-263.
3. Otis Elevators (2015), *A United Technologies Companys*, Accessed and Retrieved from [www.otisworldwide.com](http://www.otisworldwide.com) on 29th January, 2015.
4. Marjolein, D (2016). Lifting Operations and Lifting Equipment. [https://oshwiki.eu/wiki/Lifting\\_operations\\_and\\_lifting\\_equipment](https://oshwiki.eu/wiki/Lifting_operations_and_lifting_equipment). Accessed on December, 2017.
5. Côté J. N., Ngomo, S., Stock S., Messing, K., Vézina, N., Antle D., Delisle, A., Bellemare M., Laberge, M, and St-Vincent Marie (2013). Quebec Research on Work-related Musculoskeletal Disorders. *Relations Industrielles* 68 (4): P. 643.
6. Kuorinka I., Jonsson B., Kilbom A., Vinterberg H., Biering-Sørensen F., Andersson G., and Jørgensen K. (1987). Standardised Nordic questionnaires for the analysis of musculoskeletal symptoms. *Applied Ergonomics* 18 (3): PP. 233–237
7. Vander Werf, H. T. (2013). Portable Balcony Crane. A Baccalaureate thesis submitted to the School of Dynamic Systems College of Engineering and Applied Science University of Cincinnati, in partial fulfillment of the requirements for the degree of Bachelor of Science in Mechanical Engineering Technology.
8. Sharma, P.C. and Aggarwal, D.K. (2006). *Machine Design*. S.K. Kataria and Sons, NaiSarakDechi. kataria books @ yahoo.com. pp. 121-125, 225-258, 483-520, 642-684.
9. Steel Tube Institute of North America (2017). Metric Dimensions and Sections Properties <http://www.steeltubeinstitute.org>. Accessed on December, 2017.
10. Beer, P. B and Johnston, E. R (1992). *Mechanics of Materials*. McGraw-Hill, Inc. United States of America, 2<sup>nd</sup> Ed., 710 -711.
11. Cordage Institute-International Standard (2006). Nylon (Polymaid) Fiber Rope. 3-Strand and 8-Strand Plaited Constructions. [www.ropecord.com/cordage/publications/docs/CI1303.pdf](http://www.ropecord.com/cordage/publications/docs/CI1303.pdf).
12. NYLATECH (2017). Sheave Design Manual. [www.nylatech.com](http://www.nylatech.com). Accessed on December, 2017.
13. Burr, A.H. and Cheathan J.B (2002). *Mechanical Analysis and Design* (2nd edition) Prentice Hall Publishers, New Delhi.
14. Khurmi, R.S. and Gupta, J.K. (2005). *A Textbook of Machine Design* (S.I. Units) Eurasis Publishing House (PVT) Limited, New Delhi-110055.
15. Loosco Inc. Wire and Wire Rope Division (2017). Pulley and Sheave Product Catalog. [www.loosco.com](http://www.loosco.com). Accessed on December, 2017.
16. Atlantic Product (2015). Atlantic Winches. [www.atlanticproducts.com.au](http://www.atlanticproducts.com.au)
17. Khurmi, R.S (2013). *A Textbook of Engineering Mechanics*. S. CHAND and Company PVT. Ltd. RAM NAGAR, New Delhi-110055. Pg. 198-199
18. *Engineering Spreadsheets* (2003). Bolt Load Capacity Tables to BS5950 Part 1.



19. Mardrep (2018) Procedure for Testing and Examining Lifting Appliances and Loose Gear. [www.mardep.gov.hk/en/msnote/pdf/msin1294anx1.pdf](http://www.mardep.gov.hk/en/msnote/pdf/msin1294anx1.pdf). Accessed January 2018.

