

IMPROVED REMOTE-CONTROL WIRELESS SENSING SYSTEM OF PLANT GROWTH FACTORS IN GREENHOUSE ENVIRONMENT

远程控制型温室环境植物生长要素无线检测系统

Ph.D. Bin Li¹⁾, Stud. Yuqi Zhang¹⁾, Ph.D. Ying-Nan Kan¹⁾, Prof. Yao-Dan Chi¹⁾, Prof. Xiaotian Yang^{*1)},
Ph.D. Jianing Wang²⁾, Prof. Yiding Wang²⁾

¹⁾ Institute of Electrical & Computer, Jilin Jianzhu University, Changchun 130012, P.R. China;

²⁾ State Key Laboratory on Integrated Optoelectronics, College of Electronic Science and Engineering, Jilin University, Changchun 130012, P.R. China;

Tel: +86-043184566184; E-mail: 870731919@qq.com

Keywords: greenhouse, remote control, infrared gas sensor, wireless communication

Abstract

Plant growth factors including carbon dioxide, temperature, humidity and luminance have been detected by using the proposed remote-control wireless sensing system in greenhouse environment. These factors are crucial for photosynthesis and can be detected in real-time by this system. Numerical sensors were adopted and were driven by the developed printed circuit boards. Remote-control and wireless data transmission were also performed and improved by using the developed hardware. In order to satisfy the requirement of remote control, GSM module was integrated in the sensing system. Meanwhile, corresponding software was developed for data storing, wireless transmitting, remote controlling and data analyzing. The proposed system is suitable for precision management of key factors in greenhouse and it also exhibits improved functional performance compared with our previously reported sensing system.

摘要

研制了远程无线检测系统，适用于检测温室中的多种植物生长要素，包括二氧化碳、温度、湿度和光照度。这些植物生长要素是光合作用所必需的，可以通过研制的检测系统进行实时检测。多种传感器在系统中被采用，通过研制的电路板进行驱动。通过使用研制的硬件部分，远程控制和无线数据传输功能均得到实现和改进。为了满足远程控制的需求，系统中采用了 GSM 模块进行远程数据通信。同时，也开发了相应的软件，用于实现数据存储、无线传输、远程控制和数据分析等功能。通过和我们之前研制的系统相比，文中的系统在功能和性能方面得到了提高，该系统适用于温室中多项植物生长要素的精确测控。

INTRODUCTION

Greenhouses have been designed and developed to extend the production season for increasing production and improving crop quality (Danish et al. 2018; Hwang et al. 2010; Searchinger et al. 2008). It is a very important type of facilities in the modern agricultural industry around the world and it has been developed and enhanced in recent years. Environmental factors inside greenhouses such as temperature, humidity, gas fertilizer and luminance can be detected and regulated by climate-regulating equipment, sensing devices and control units. These facilities must achieve accurate, convenient, stable and cost-effective goals in order to meet the requirements practically. In this way, the demand of adequate high-tech greenhouse facilities becomes increasingly significant and many research groups have studied in this field in recent years (Sahbani et al. 2018; You et al. 2017; Jianing et al. 2016). According to the recent reports (Erazo-Roads et al. 2018; Sivamani et al. 2018; Bai et al. 2018; Somov et al. 2013), the growing use of sensing technique, wireless data communicating technique and digitalized data management technique are highlighted for high-precision sensing and dynamic modeling & controlling of climate factors in greenhouse environment.

Sensors have been widely adopted in greenhouses to detect the environmental factors such as temperature, humidity, gas concentration and luminance. These sensors are integrated by using different principles and have been optimized along with the development of sensing techniques (Yasuda et al. 2012; Suzuki et al. 2018; Lambrecht et al. 2016; Ferrero et al. 2018). In recent years, optical gas sensors have been studied by researches to replace the traditional chemical sensors.

Optical sensors generally have longer lifespan, quicker response time, larger sensing range and higher sensitivity (Charles *et al.* 2014; Kapsalidis *et al.* 2018; Wei *et al.* 2014; Fisher *et al.* 2018; Jiang *et al.* 2018). In this way, carbon dioxide (CO₂), which is a key element in the photosynthesis phenomenon, can be detected by using optical sensors as a part of the comprehensive sensing & controlling system in greenhouses.

In recent years, wireless sensor networks (WSNs) have been widely adopted in the agricultural industry especially in modern greenhouses (Jahnavi *et al.* 2015; Park *et al.* 2011). Data detected by sensors can be transmitted from sensor nodes to network receivers by using wireless systems. This results in two major benefits than using cables including cost-effective construction and convenient deployment of the sensing system especially in large greenhouses that need hundreds of sensor nodes. With the increasing of sensing targets and sensor node numbers, digitalized data management becomes indispensable during the process of data transmission, data storage, signal processing and analyzing. Therefore, effective and reliable data management in quick response time is necessary.

In this paper, an improved remote-control wireless sensing system of plant growth factors in greenhouse is proposed. Compared to our previous work (Bin *et al.* 2018), there are three major improvements. Firstly, the developed wireless sensor node was further integrated with a GSM module. In this way, the sensor node is not only able to connect with the laptop which places in the adjacent control room, but also can send data via the GSM module to a remote PC which is about 20 kilometres away from the greenhouse. Therefore, the detected data can be displayed, stored and analyzed remotely. Secondly, based on the infrared CO₂ sensor and the remote-control mode, adjustable PID algorithm has been applied to sensing system in greenhouse. Finally, a concise and customized web page has been designed and published in this system by using LabVIEW. Therefore, the remotely collected data can be stored and viewed by the developed software for further operation. In the end of this paper, experiments were carried out by using the improved sensing system and results were discussed correspondingly.

MATERIALS AND METHODS

System structure

The improved remote-control sensing system consists of three major parts which are located in the greenhouse, the control room which is close to the greenhouse through a thin wall and a remote control laboratory 20 kilometres away from the greenhouse. The basic schematic diagram of the system is as shown in Figure 1. Firstly, an integrated sensor node is located in the greenhouse to detect numerous analogue signals including temperature, humidity, CO₂ concentration and luminance. Secondly, laptop installed software developed by using LabVIEW is located in the control room of the greenhouse. This sensor node is able to transmit digital data by using the 433 MHz wireless module to the local wireless receiver which is linked to this laptop in the control room. In addition, a GSM module is integrated inside the sensor node for remote signal communication. In this way, the sensor node can also send the detected data to the PCs located in the lab in the university. Thirdly, the computers located in the lab have also installed software developed by using the LabVIEW platform in order to process the received data. The detailed functions of the developed software are shown in the following sections in this paper.

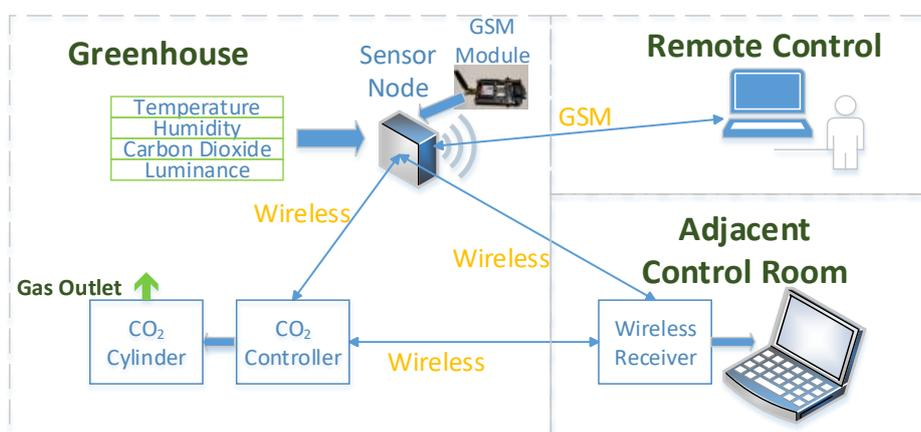

Fig. 1 - Structure diagram of the developed sensing system of plant growth factors

Wireless sensor node and data management

The sensor node was developed to perform sensing and data transmission functions. Ambient factors including temperature, humidity, CO₂ concentration and luminance can be detected by the integrated sensors. The main controller is a 32-bit chip (STM32F103R) with a maximum CPU speed of 72 MHz. The sensor node also consists of wireless modules. One is the 433 MHz local wireless communication module and the other is a GSM module which is responsible for remote-controlled signal transmission. Therefore, the detected greenhouse data can be both transferred to the local laptop which is located in the adjacent control room and the remote-control lab via the GSM module. The developed data management software system consists of three parts of functions. Firstly, data communication and synthesis are performed by this system including display, storage, remote-control and data share etc. Secondly, the fuzzy PID algorithm is adopted and PID characters were adjusted based on analyses and experiments. Thirdly, the software has been developed with good compatibility feature in order to be transplanted to other platform. The detailed structure of the developed software is shown in Figure 2. In this program, the essential characters are firstly initialized and the receiving data is read by using the Serial Communication Interface (SCI). Then, the key modules of the software start to work to perform synchronization of display, database and network. In this way, the further operation can be performed based on the settings to perform PID control, communication adjustment and sensor node status verification etc. In the end of the loop, important data and logs are separately stored and displayed for further operation.

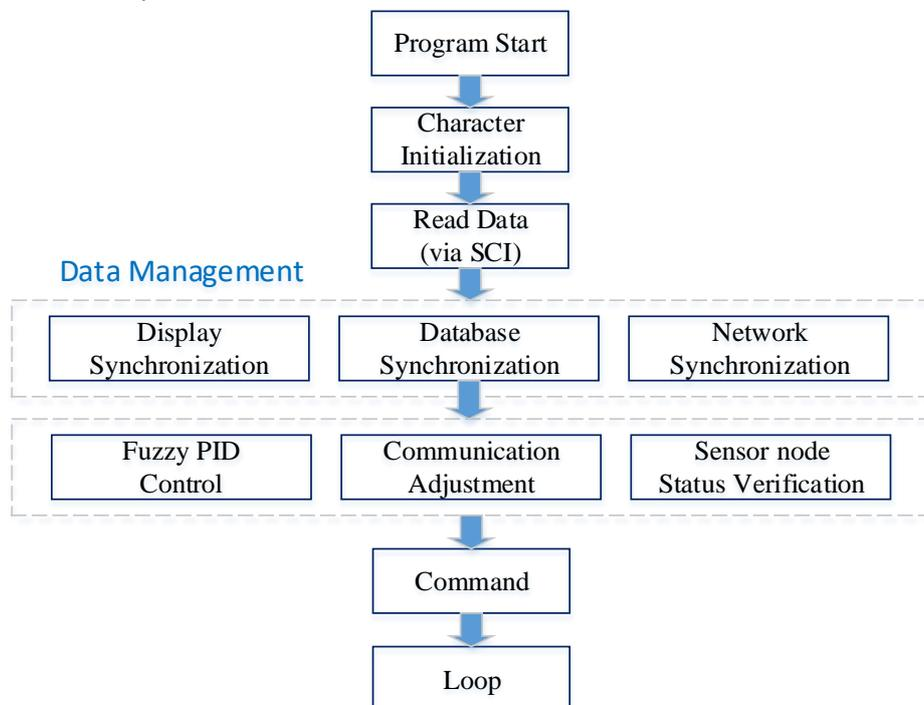

Fig. 2 - Function diagram of the developed data management system

Fuzzy PID control algorithm

Generally, a fuzzy PID control system consists of input & output ports, execution unit, controlled object and fuzzy controller. In the adopted system which is shown in Figure 3, the input & output ports are the communication interfaces of the wireless sensor node, the control laptop and the remote-control computer. The communication includes voltage level switch, communication coding and decoding and other requirements. The execution unit in the system includes an electromagnetic valve, a relay and corresponding driving circuits. The controlled object is CO₂ concentration in greenhouse and the detection unit is the developed sensor node. The fuzzy PID controller is the core of the system. In the developed system, this controller was based on the LabVIEW platform in order to shorten development period.

There are several working steps of the fuzzy PID controller. Firstly, the wireless sensor node detects environmental factors in the greenhouse and sends data to the remote control system. Then, the input variable values are processed to be fuzzy values according to the structure of the adopted fuzzy PID controller. And the fuzzy control values can be obtained based on the fuzzy rule table and corresponding

calculations are performed. Then, precise control value can be obtained in the reverse fuzzy process for the execution unit to perform specific adjustment and modulation. In this way, the CO₂ gas valve can be switched according to the system command based on the measured CO₂ concentration. Therefore, a closed loop of fuzzy PID control process has been established.

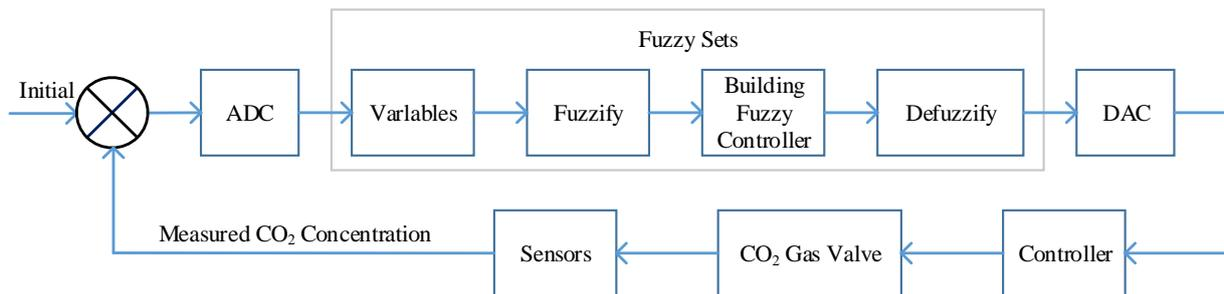

Fig.3 – Function diagram of the adopted control strategy based on fuzzy PID algorithm

In addition, the PID factors are repeatedly adjusted based on LabVIEW which is shown in figure 4 in order to achieve optimized response speed and high stability of the control system.

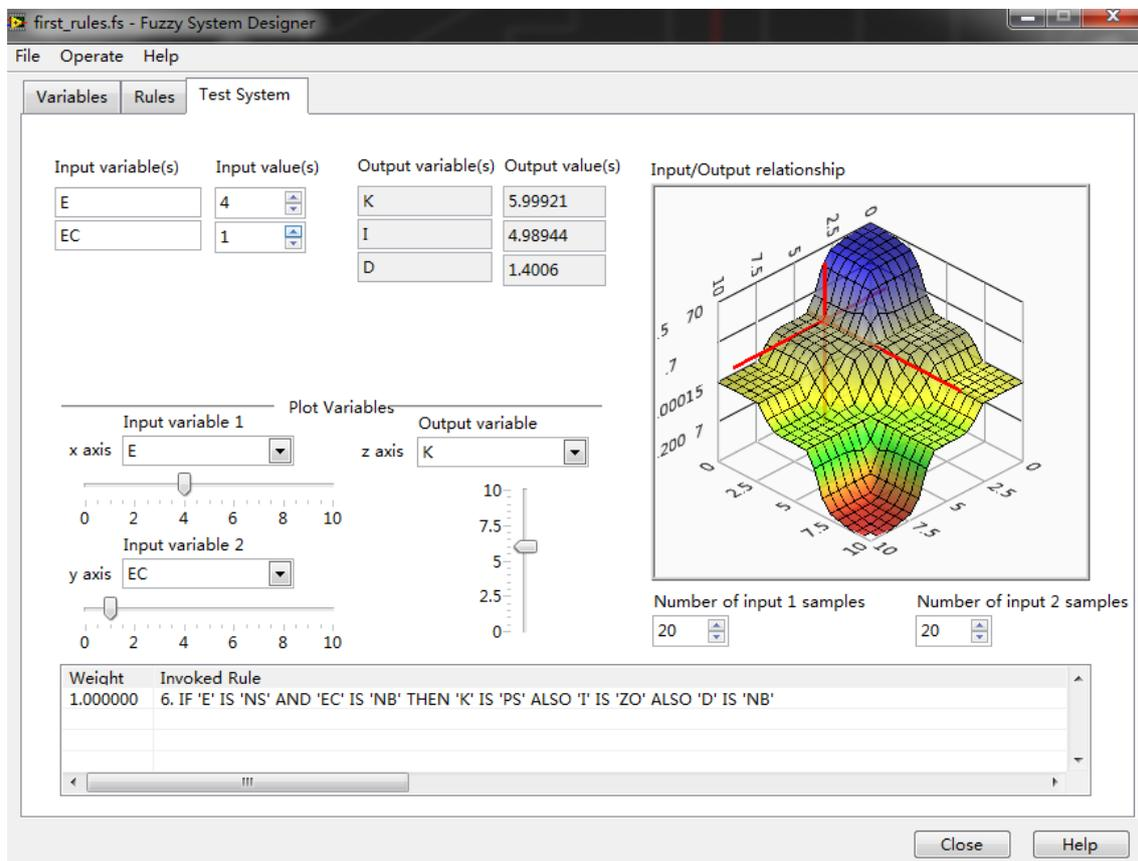

Fig. 4 - Photo of the adjusted PID characters based on LabVIEW platform

Remote-control based on GSM communication

The detected data in the greenhouse can be remotely transmitted to the lab by using the integrated GSM module. Based on the LabVIEW platform, interface of displaying sensing data has been developed as shown in Figure 5. The developed interface supports remotely data synchronism based on dashboard functions in LabVIEW which is shown in Figure 5 (a). This interface can be applied on multiple terminals such as PCs, laptops, iPads and Android devices. In this way, the detected data in greenhouse can be viewed conveniently by using varies devices. In the future, multiple sensor nodes will be applied experimentally and this interface can also be expended to support multiple sets of sensing data.

The program based on LabVIEW has been developed by several steps. Firstly, the developed program was coded according to the requirements and packaged in a project.

Then, there are two options to perform data synchronism which are whole program synchronism and variable values synchronism.

The second option was applied in this project according to the comparison experiments which demonstrated better fluency than the first option.

Therefore, the variable values synchronism option was chosen. In this option, variable values of detected data including temperature, humidity, gas concentration and luminance were named separately for synchronism in both local and remote computers. Meanwhile, service station of DNS (Domain Name System) was established. Then, monitoring interface was developed and was linked to these variable values. Finally, the established DNS was chosen and tested in order to implement the synchronism function of these detected environmental data in greenhouse.

Generally, web pages are designed and developed for viewing in variable devices. In this project, web pages based on LabVIEW platform were also developed to present the detected data and status data. Before publishing the web pages, basic settings including HTTP ports, SSL ports and VI root folder must be determined. Then, remote access authority was permitted and variable values are registered for synchronous access. In this way, the detected data in greenhouse can be monitored by using the developed web pages. The gas valve can be remotely controlled as well by using the interface. The developed interface is shown in Figure 5 (b) including monitoring windows and functional buttons.

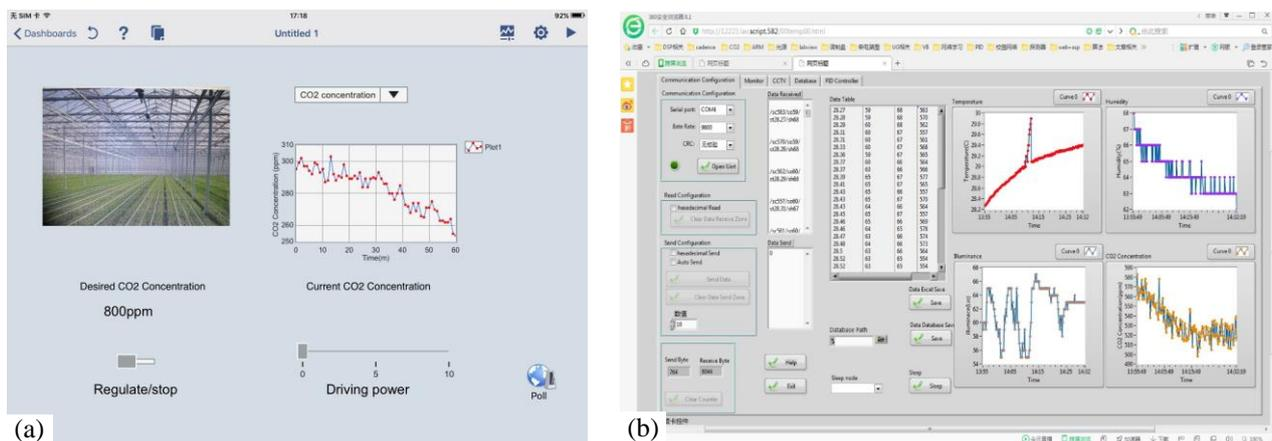

Fig. 5 - Developed remote-control system interface (a) and published web page (b) based on LabVIEW platform

RESULTS

Experiments setup

The developed sensor node was deployed in the greenhouse as shown in Figure 6 (a) to detect environmental factors including temperature, humidity, CO₂ concentration and luminance.

Many small holes have been drilled in the case of the sensor node for air exchanging between the inside and outside of the sensor node. Meanwhile, these holes have been covered with special waterproof film which ensures ventilation. Therefore, the environmental CO₂ concentration can be detected by the integrated gas sensor.

The temperature and humidity sensor is linked with a cable and is able to detect both air and soil temperature and humidity value. The luminance sensor is embedded on the front panel faced to the illumination side in the greenhouse. The greenhouse, which occupies 640 m³, is located 20 kilometres away on Google map from the remote-control lab in the university as shown in Figure 6 (b).

The entire zone of the university, the greenhouse and nearby areas are completely covered with 2G, 3G and 4G telecommunication signals. Corresponding base stations have been deployed on masses of signal towers. In this way, the detected data in the greenhouse can be delivered to the remote-control lab via these facilities with affordable charges.



Fig. 6 – Experimental setup of the sensor node in the greenhouse (a) and geography view of the system (b)

Local wireless signal test

The in-situ wireless communication performance can be evaluated by detecting RSSI (Received Signal Strength Indication) in different conditions. There are two significant performance indicators related to RSSI of the antenna which are direction and distance. In this project, the sending and receiving direction of the sensor node is unfixed. In addition, it has been considered that multiple sensor nodes will be adopted in further experiments. Therefore, omnidirectional antenna has been applied in order to achieve good compatibility.

The antenna was placed upward and RSSI value was tested in different distances as shown in Figure 7 (a). The angle of antenna has been changed by using the step of 45 degree and corresponding RSSI was detected and recorded. It can be seen that RSSI value remains stable in different angles of antenna while the distance was fixed. The fluctuation can be considered as the error of detection and operation. Results demonstrate that the impact of antenna direction can be neglected. In this way, the position of the sensor node can be flexible and further experiments involving wireless communication of multiple sensor nodes can be realized efficiently.

The detection error of RSSI was experimentally evaluated while the sending power was set as 20 dBm in a small tomato greenhouse. The greenhouse occupies an area of about 640 square meters with the length of 80 meters. The wireless communication experiments were carried out to evaluate the transmission performance as shown in Figure 7 (b). The detection error was calculated in each distance from 0 to 80 meters. It can be seen that the detection error rises while the transmission distance surpasses 75 meters in the figure. However, considering the length of the greenhouse and reasonable sensing location, the overall detection error of RSSI remains stable in the greenhouse.

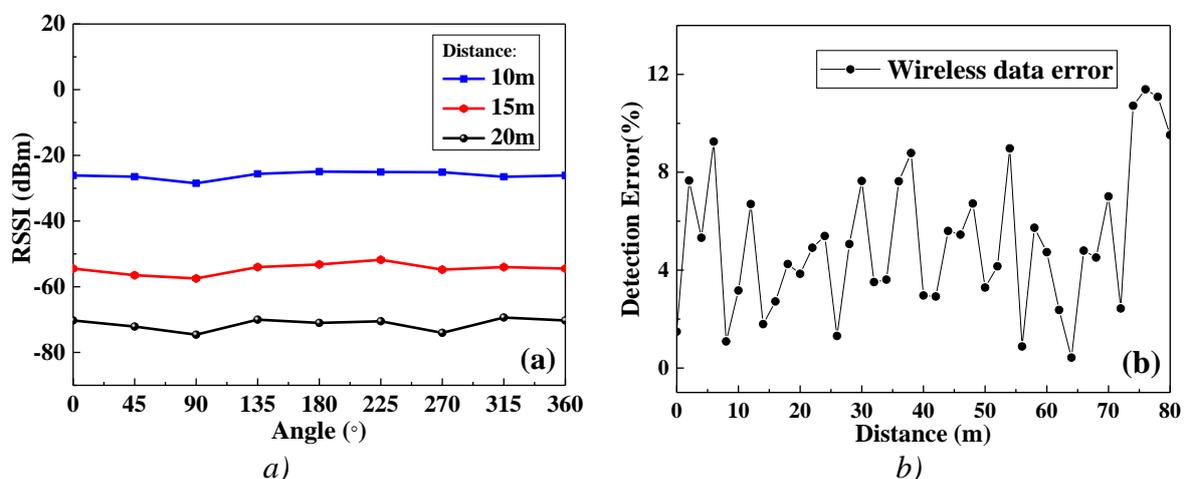

Fig. 7 - Tests of RSSI value in different angles (a) and detection error in different distances (b) in the greenhouse

Remote-controlled measurements of factors

Remote-controlled measurements of key factors were performed while the preparations were implemented including placement of the sensor node, wireless communication tests and software development. Environmental factors in greenhouse were detected and transmitted to the lab. During a period of 7 hours from 10 a.m. to 5 p.m., CO₂ concentration and luminance were detected and plotted in Figure 8.

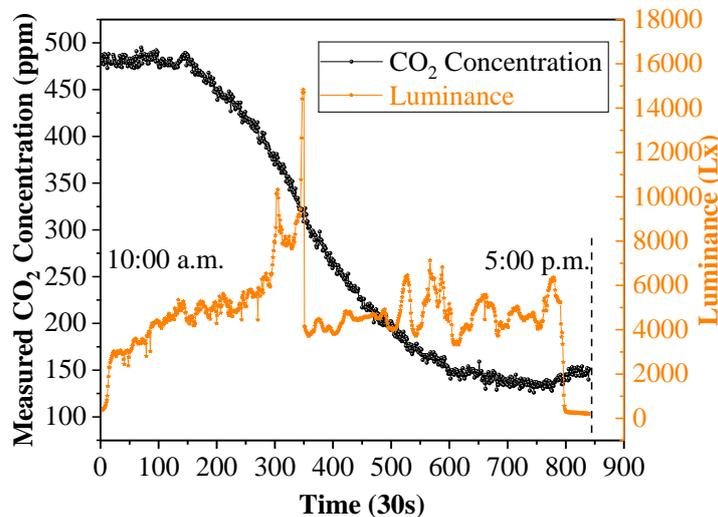

Fig. 8 - Detection of CO₂ concentration and luminance in the greenhouse in 7-hour period

The CO₂ concentration continually decreased from beginning to the end during this period of time. The decrease was caused by the photosynthesis phenomenon. In the sealed greenhouse, ventilation was prevented for warm keeping so the consumed part of CO₂ cannot be supplied by the outside cold air. Then, the roll blind machine started to cover the greenhouse at 4:30 p.m. in order to achieve good heat insulation. In this way, the photosynthesis was terminated because of the lack of sunshine and the decrease of CO₂ concentration stopped as well. The luminance value varied corresponding to the brightness in the greenhouse. It increased from the beginning and mainly maintained in a scope from 3000 – 6000 Lx during the 7 hours. For a short period of time at noon, the luminance reached a peak value at about 15000 Lx and then dramatically decreased to its scope. The peak value of luminance could be caused by the direct ray of light on the sensor. The luminance sharply decreased to zero when the greenhouse was covered with thick light-proof material by the roll blind machine. It can be seen from the figure that the CO₂ concentration and luminance can be effectively detected by using the remotely controlled system. The environmental data can be detected accurately and quickly.

The CO₂ concentration can be controlled to maintain a relative high level. In this way, the photosynthesis process can be ensured because there is sufficient supply of CO₂ in greenhouse. Fuzzy PID is adopted as the control algorithm in the controlling process. Experiment was carried out to evaluate the result as shown in Fig. 9.

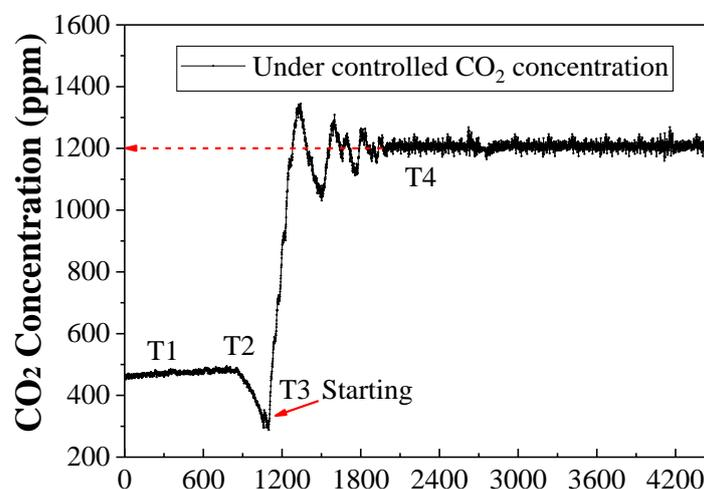

Fig. 9 – Experiment of CO₂ detection under Fuzzy PID control in the greenhouse

During the T1 and T2 period, the CO₂ concentration has been influenced by the environmental factors in the greenhouse without control. The control process starting in the period of T3 and the target value was set as 1200 ppm. As shown in the figure, the concentration of CO₂ has been raised sharply and then has fluctuated. This self-modulation period lasts about 1 hour. Then, in the period of T4, the CO₂ concentration maintains at a relative stable level around 1200 ppm. Therefore, compared with data in Figure 8, the CO₂ concentration can be effectively controlled in the greenhouse by using the fuzzy PID algorithm in order to provide enough gas fertilization for photosynthesis.

Meanwhile, ambient humidity and temperature in the greenhouse were also detected as shown in Fig. 10.

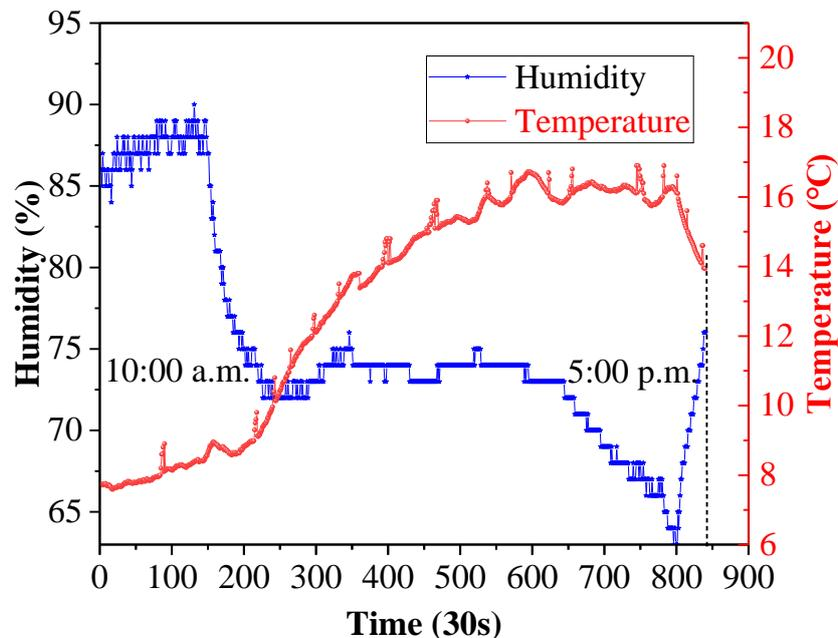

Fig.10 - Detection of humidity and temperature in the greenhouse in a 7-hour period

In figure 10, it can be seen that the humidity and temperature appear opposite trend during the 7 hours. The humidity value fluctuated in the day time from 85% to 60%. This can be also caused by the photosynthesis phenomenon. The deduced part of humidity was absorbed by plants in the photosynthesis process. The temperature value increased from approximately 8°C in the morning and reached its peak value at about 16°C in the afternoon. The temperature value started to decrease at 4:30 when the greenhouse was covered by the roll blind machine. According to our previous 24 hours detection experiments, the temperature maintained over 7°C during the night. Therefore, the plants can be protected from frozen damage in nights. The humidity and temperature value can be detected and transmitted to the lab in real time effectively.

CONCLUSIONS

The proposed remote-control wireless sensing system has been developed for detecting plant growth factors including temperature, CO₂, humidity and luminance in greenhouse environment. The above factors are essential for photosynthesis and can be detected in real-time by this system. The corresponding sensors have been adopted and were driven by the developed printed circuit boards in this system. Remote-control and wireless data transmission were also realized and optimized by using the developed circuits. In order to meet the demand of remote control, GSM module has been integrated in the sensing system. In addition, software has been developed to perform data storing, wireless communication, remote controlling and data analyzing. According to the experiments, the proposed system is suitable for precision management of key factors in greenhouse. It also exhibits optimized functional performance compared with our previously reported sensing system. In the future, based on the remote-control feature, more sensors will be adopted in this system in order to establish a remote-control sensing network in greenhouse environment.

ACKNOWLEDGEMENT

The authors wish to express their gratitude to the National Natural Science Foundation of China (No. 51672103), Jilin Jianzhu University (201810191114, 201810191115, 201810191023), the National Key Technology R&D Program of the Ministry of Science and Technology of China, the Science and Technology Department of Jilin (20180201052SF, 20180201063SF), Province of China and the Education Department of Jilin Province of China (JJKH20180573KJ, JJKH20170240KJ) for the generous support of this work.

REFERENCES

- [1] Bai X.Z., Wang Z.D., Zou L. et al., (2018), Collaborative fusion estimation over wireless sensor networks for monitoring CO₂ concentration in a greenhouse, *Information Fusion*, Vol. 42, Elsevier Science BV, 1566-2535, pp.119-126, Amsterdam/Netherlands;
- [2] Bin Li, Jitong Wang, Yaodan Chi et al., (2018), Wireless measurement and control system of carbon dioxide using infrared sensor in greenhouse environment, *INMATEH – Agriculture Engineering*, Vol. 54, pp.1583-1019, pp.47-54, Bucharest/Romania;
- [3] Danish M, Sheikh, H, (2018), Effect of SiO₂ Nanoparticles on the Interaction of *Pseudomonas fluorescens* and *Meloidogyne incognita* in *Trachyspermum ammi* under Greenhouse Conditions, *Phytopathology*, Vol. 108, Amer Phytopathological Soc, 0031-949X, pp.48-48, Boston/U.S.A;
- [4] Erazo-Rodas M., Sandoval-Moreno M., Munoz-Romero, et al., (2018), Multiparametric Monitoring in Equatorial Tomato Greenhouses (I): Wireless Sensor Network Benchmarking, *Sensors*, Vol.18, no.8, pp.(2555)1-22, MDPI AG, 1424-8220, Basel/Switzerland;
- [5] Ferrero R., Beattie E., Phoenix J., (2018), Sensor City- A Global Innovation Hub for Sensor Technology, *IEEE Instrumentation & Measurement Magazine*, Vol.21, pp.4-16, IEEE-Inst Electrical Electronics Engineers INC, 1094-6969, NJ/U.S.A;
- [6] Fisher E.M.D., Benoy T., (2018), Interleaving and Error Concealment to Mitigate the Impact of Packet Loss in Resource-Constrained TDLAS/WMS Data Acquisition, *IEEE Transactions on Instrumentation and Measurement*, Vol.67, pp.439-448, IEEE-Inst Electrical Electronics Engineers INC, 0018-9456, NJ/U.S.A.;
- [7] Hwang J., Shin C., Yoe H. (2010), A wireless sensor network-based ubiquitous paprika growth management system, *Sensors*, Vol.10, pp.11566-11589, DPI AG, 1424-8220, Basel/Switzerland;
- [8] Jahnvi V.S., Ahamed S.F., (2015), Smart Wireless Sensor Network for Automated Greenhouse, *IETE Journal of Research*, Vol.61, pp.180-185, Taylor & Francis LTD, 0377-2063, Oxon/England;
- [9] Jianing Wang, Lingjiao Zheng, Xintao Niu et al., (2016), Mid-infrared absorption-spectroscopy-based carbon dioxide sensor network in greenhouse agriculture: development and deployment, *Applied Optics*, Vol. 55, Issue 25, pp.7029-7036, Optical Soc. Amer, 2155-3165, Washington, D.C./U.S.A.;
- [10] Jiang M., Zhou P., Gu X.J., (2018), Ultralong pi-phase shift fibre Bragg grating empowered single-longitudinal mode DFB phosphate fibre laser with low-threshold and high-efficiency, *Scientific Reports*, Vol.8, Nature Publishing Group, 2045-2322, London/England;
- [11] Kapsalidis F., Shahmohammadi M., Suess M.J. et al., (2018), Dual-wavelength DFB quantum cascade lasers: sources for multi-species trace gas spectroscopy, *Applied Physics B-Lasers and Optics*, Vol.124, no.6, pp.(107)1-17, Springer, 0946-2171, NY/U.S.A.;
- [12] Lambrecht S., Nogueira S.L., Bortole M., et al., (2016), Inertial Sensor Error Reduction through Calibration and Sensor Fusion, *Sensors*, Vol.12, pp1-16, MDPI AG, 1424-8220, Basel/Switzerland;
- [13] Park D.H., Park J.W., (2011), Wireless Sensor Network-Based Greenhouse Environment Monitoring and Automatic Control System for Dew Condensation Prevention, *Sensors*, Vol.11, pp.3640-3651, MDPI AG, 1424-8220, Basel/Switzerland;
- [14] Sahbani F., Ferjani E., (2018), Identification and Modelling of Drop-By-Drop Irrigation System for Tomato Plants Under Greenhouse Conditions, *Irrigation and Drainage*, Vol. 67, pp.550-558, WILEY, 1531-0353, Hoboken/U.S.A.;
- [15] Searchinger T., Heimlich R., Houghton R.A. et al, (2008), Use of US croplands for biofuels increases greenhouse gases through emission from land-use change, *Science*, Vol.319, pp.1238-1240, Amer. Assoc. Advancement Science, 0036-8075, Washington, D.C./U.S.A.;

- [16] Somov A., Baranov A., Spirjakin D., et al. (2013), Development and evaluation of a wireless sensor network for methane leak detection, *Sensors and Actuators A*, Vol.202, pp.217-225, Elsevier Science SA, 0924-4247, Lausanne/Switzerland;
- [17] Sivamani S., Choi J., Bae K. et al., (2018), A smart service model in greenhouse environment using event-based security based on wireless sensor network, *Concurrency and Computation-Practice & Experience*, Vol. 30, pp.171-184, Wiley, 1531-0353, Hoboken/U.S.A.;
- [18] Suzuki K, Oota H., Umeyama T., (2018), Development of Corrosion-Resistant Pressure Sensor with Semiconductor Strain Sensor, *Electrical Engineering in Japan*, Vol.203, pp.58-65, WILEY, 1531-0353, Hoboken/U.S.A.;
- [19] Wei Ren, Wehze Jiang, Nancy P. Sanchez, et al., (2014), Hydrogen peroxide detection with quartz-enhanced photo acoustic spectroscopy using a distributed feedback quantum cascade laser, *Applied Physics Letters*, Vol.104, pp.(041117)1-5, Amer. Inst. Physics., 0003-6951, NY/U.S.A., 041117;
- [20] Wynn C., Palmacci St., Clark M. et al., (2014), High-sensitivity detection of trace gases using dynamic photo-acoustic spectroscopy, *Optical Engineering*, Vol.53, pp.(021113)1-5, SPIE-SOC Photo-Optical Instrumentation Engineers, 0091-3286, Bellingham/U.S.A., 021103;
- [21] Yasuda T., Yonemura S., Tani A., (2012), Comparison of the characteristics of small commercial NDIR CO₂ sensor models and development of a portable CO₂ measurement device, *Sensors*, Vol.12, pp.3641-3655, MDPI AG, 1424-8220, Basel/Switzerland;
- [22] You S.M., Tong H.H., Armin H.J. et al., (2017), Techno-economic and greenhouse gas savings assessment of decentralized biomass gasification for electrifying the rural areas of Indonesia, *Applied Energy*, Vol.208, pp.495-510, ELSEVIER SCI LTD, Oxford/England.