

RESEARCH AND DEVELOPMENT OF AIR-SUCTION CORN PRECISION SEED METERING DEVICE

气吸式精量玉米播种器的研究与开发

Prof. Ph.D. Eng. Lv Xiaorong^{*1)}, Prof. Ph.D. Eng. Zhang Lihua¹⁾, Ph.D. Eng. Lv Xiaolian²⁾,
M.A. Stud. Eng. Tian Zhiwei¹⁾

¹⁾ Sichuan Agricultural University, College of Machinery & Electronics/China;

²⁾ Chuzhou University, College of Machinery & Automotive Engineering/China
Tel: 08352882182; E-mail: lxxj2008@163.com

Keywords: corn, seed metering device, detection and control system, reseeding device, performance test

ABSTRACT

The air-suction seed metering device with automatic detection and reseeding function was designed. The device is mainly composed of metering disc, reseeding device, detection system, signal processing and control system, alarm device and power supply. Based on the photoelectric sensors, the seed metering device is detected. The timed reseeding function was realized through the detection and control system. The correlation performance tests were done by comprehensive weight score value method. The test results had shown that: under the operating conditions of 4kPa and 15r/min, the seed metering device has the best seeding effect; the qualification rate of the seed metering device with the reseeding device is 93.68%, the over-seeding rate is 3.91%, the miss-seeding rate is 2.38%; compare the installed reseeding device with the uninstalled reseeding device, the qualification rate of the seed metering device is increased by 2.34% and the miss-seeding rate is dropped by 3.09%, and the seeding quality of the seed metering device has been greatly improved.

摘要

设计了一种带有自动检测与补种功能的气吸式播种器。该装置主要由排种盘、补种装置、检测系统、信号处理与控制系统、报警装置及电源等部分组成。基于光电传感器检测播种器漏播情况，通过检测控制系统实现播种器实时补种功能。采用综合加权评分法进行了试验，结果表明：当真空度为 4kPa，转速为 15r/min 时，播种器作业效果最优，装有补种装置的播种器的播种合格率为 93.68%，重播率为 3.91%，漏播率为 2.38%，相对未安装补种装置的播种器播种合格率上升 2.34%、漏播率下降 3.09%，播种质量有了较大的提升。

INTRODUCTION

Air-suction precision seeding is the main direction of corn precision seed metering device development, but currently there is a large miss-seeding problem in the seeding work (Lv X.L. et al, 2012; Shi Song et al, 2014). In recent years, many researchers have been made in the field of timed detection method and detection system for miss-seeding of the seed metering device. SINGH and others (Singh T.P. et al, 2011) used electronic control measurement system to timed monitor and feedback the seeding process of metering seed device. Jae Wan Lee and others (Jae Wan Lee et al, 2013) have studied the relationship between the vibration frequency of the metering seed disks and the PTO vibration frequency of the tractor in FlexPDE and ANSYS software. Zhou Liming and others (Zhou Liming et al, 2012; Zhu Ruixiang et al, 2014) have studied the monitoring system of the seeding performance of the corn precision seed metering device. Tian Liquan and others (Tian Liquan et al, 2016) have developed the seed metering device with the function of missing seed compensation and the device satisfied the accurate and effective reseeding requirements. Wu Jianmin and others (Zhang Xiaodong et al, 2013; Cao Dong, 2013) have researched and designed the missing seed detection and compensation system for the potato seed metering device. Ding Youchun and others (Ding Youchun, 2014; Li Ming et al, 2010) have studied the timed detection system for the missing seed of rape planting. At present, the method of delay time reseeding is adopted in the missing seed detection and reseeding systems for the precision seed metering device. It has the problems of complex structure and inaccurate reseeding. The foreign research is relatively mature, but its cost is high and unsuited for the planting mode of our country. In the paper, the air-suction corn precision seed metering device with automatic detection and reseeding device was designed, and the test was done on the influence of the working factors and the effect of the reseeding.

OVERALL SCHEME DESIGN

Structure and composition

The seed metering device mainly consists of main seed metering disc, reseeding device, detection and control system, transmission shaft, seed chamber, gas chamber and seeding pipe, as shown in Fig.1. The seed chamber and the gas chamber are installed on the transmission shaft. The gas chamber is connected with the seed chamber by the bolts. The gas chamber is connected to the fan through the gas pipe. The negative pressure of sucking seed is provided by the fan. The reseeding disc is installed on the drive shaft, and is fitted with the outside of the seed chamber. On both sides of the main seeding disc and reseeding disc a pair of photoelectric sensors is separately installed. The signal transmitter is fixed in the corresponding position of seed chamber. The signal receptor is fixed on the outside shell of the gas chamber, and corresponds to the transmitter. The sensors are used to detect the sucking seed situation on the seed metering discs. The seeding tube is installed on the frame and is located under the seed metering discs. A pair of sensors is installed in the pipe to detect the seeds flowing. The sensors are connected with the Microcontroller Unit (MCU) to transfer and deal with the signals. The MCU is connected with the stepper motor driver and control the reseeding disk sucked seed and timed reseeding.

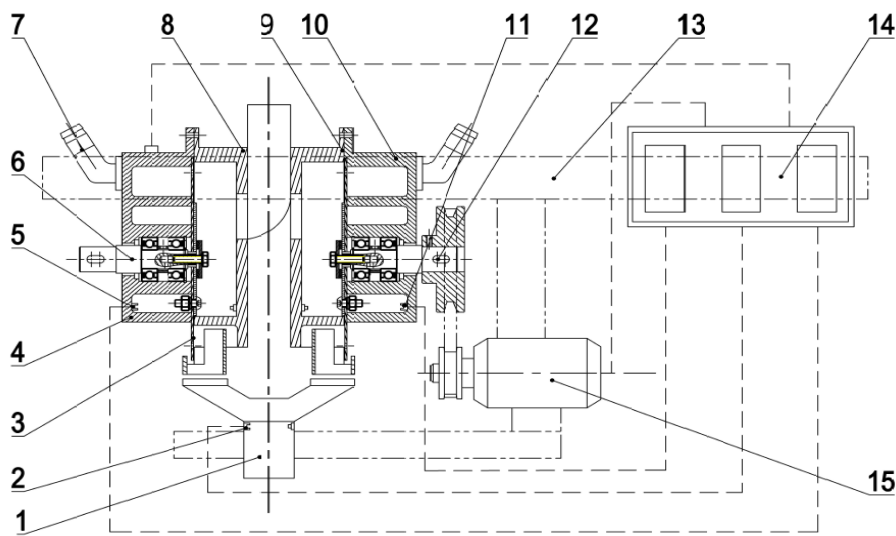

Fig. 1 - Structure diagram of the air-suction corn seed metering device

1-Seeding pipe; 2- Detection sensor I ; 3- Main seed metering disc; 4- Gas chamber; 5-Detection sensor II; 6-Main drive shaft; 7-Gas pipe; 8- Seed chamber; 9-Reseeding chamber; 10- Reseeding gas chamber; 11- Detection sensor III ;12- Reseeding drive shaft; 13-Rack; 14- Single chip microcomputer; 15-Stepper motor

As shown in Fig. 2, the detection and control system is mainly composed of the detection module, the MCU, the reseeding device, the stepper motor, the alarm module and the power supply module.

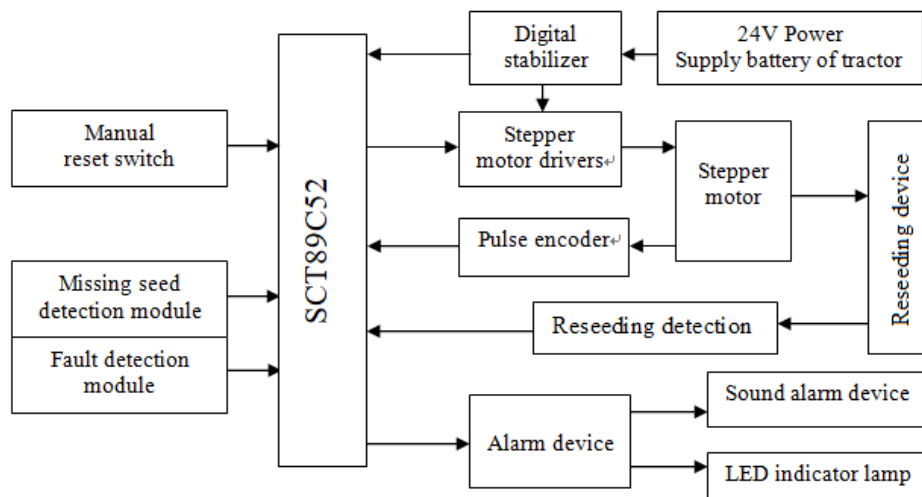

Fig. 2 - Structure block diagram of hardware system of reseeding detection

The detection module consists of three pairs of photoelectric sensors. The MCU is the core of the detection and control system. It deals with the transfer signal of the detection module and controls the operation of the reseeding device and alarm system. In order to ensure the safety and reliability of the system, the aeronautical plugs were used for the connection between each module. The working power is generated by the 24VDC power of the tractor.

MATERIALS AND METHODS

Working principle

With main seed metering disc rotated, the seeds were adsorbed on the suction holes by gas chamber negative pressure. The photoelectric sensor detected the sucking seeds situation. If the seeds were sucked on the suction hole, the signal receptor didn't receive the emission light of signal transmitter and the detection circuit was not changed so the reseeding device is in the static state. The seeds were carried out of the seed chamber. The negative pressure disappeared and the seeds fell into the seeding pipe. When there weren't seeds on the suction hole, the signal receptor received the light of the signal transmitter and the detection circuit was changed. The MCU sent out work instructions to the reseeding device according to the program setting, and started the stepper motor to drive the reseeding disc. At the same time, the photoelectric sensor installed on both sides of the reseeding disks was used to detect the next suction seed hole of the reseeding disc. When the seeds were adsorbed on the suction hole, the MCU sent out the stop instruction to the stepper motor. The sensor on the seeding pipe timely sent the pulse signal to the MCU. The seed dropping speed was reflected through the frequency of the transmitted signal. When the seed metering device has a problem, the MCU doesn't receive the pulse signal in the set time range and the alarm device starts.

DESIGN OF AUTOMATIC RESEEDING SYSTEM

Reseeding device

As shown in Fig.3, the reseeding device is mainly composed of the reseeding gas chamber, reseeding drive shaft, reseeding disc, reseeding chamber and gas pipe. The gas chamber is connected with the fan through the gas pipe and generates negative pressure. The gas chamber is installed on the drive shaft through a bearing and fixedly connected with the bracket. The reseeding chamber is installed on the gas chamber. The reseeding disc is installed on the driver shaft and is attached to the outside of the gas chamber and of the reseeding chamber. The reseeding disc rotates to the gas chamber and the reseeding chamber by the reseeding drive shaft. The MCU controls the rotation of the reseeding disc to real-time reseeding. When the seed metering device missed a seed, the control system controlled the metering seed disc to perform timed reseeding. The motor received the pulse signal from the control system, and then converted the pulse signal into the angular value (Li Leixia, 2012). The stepper motor 86BYGH250C is adopted. The 32 bit DSP digital type stepper motor driver HB-860H is selected, adopts PWM current control and the working voltage is 24VDC.

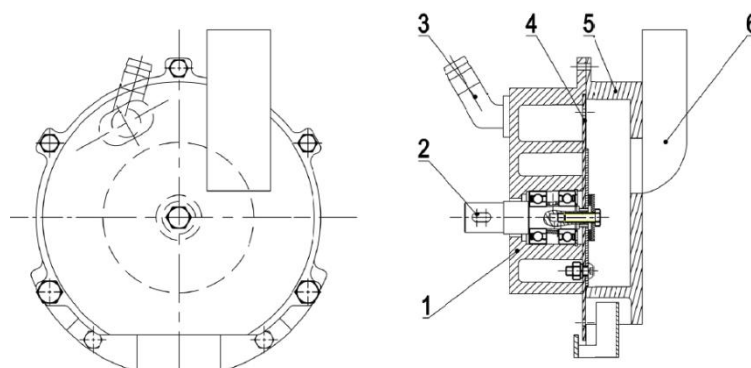

Fig. 3 - Structure diagram of the reseeding device of air suction corn precision seed metering device

1- Reseeding gas chamber; 2-Reseeding drive shaft; 3- Gas pipe; 4-Reseeding disc; 5-Reseeding chamber; 6- Adding seed pipe

Detection and control system

The detection device is provided the reseeding signal according to the output level of the sensor. When the suction seed hole had seed, the light of the laser transmitter was shielded, the laser receptor was unable to receive the light signal and output the high level. When the suction seed hole had no seed, the

laser receptor received the optical signal and outputted a low level. When the seed was normally falling, the sensor outputted a continuous high level signal. When the device had a problem, the sensor outputted a continuous low level signal. The starting of the alarm device is determined by the test result of the discriminating circuit. The M12 laser sensor is used to detect seed on the suction seed hole, and the HD-DS25CM-3MM photoelectric sensor is used to detect the seed flowing in the seeding pipe. The signal conversion circuit of the photoelectric sensor is shown in fig. 4.

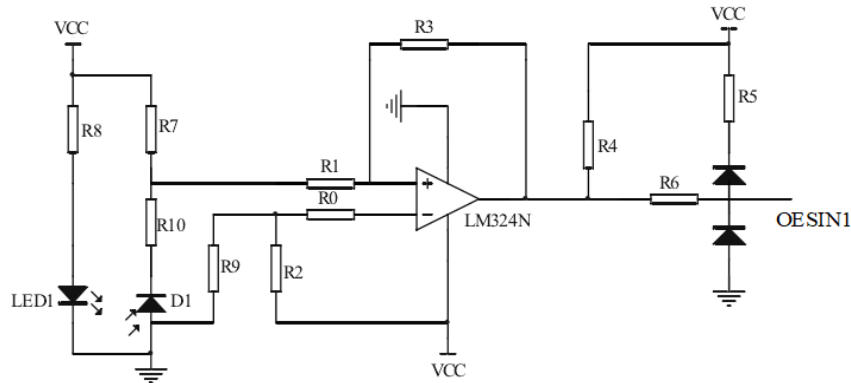

Fig. 4 - Circuit diagram of the signal conversion

The signal processing and control module is the core of the detection and control system (Sun Wei et al, 2016; WANG Lifen, 2015). As shown in Fig. 5, the system needs to deal with more comprehensive information, so that the digital analog hybrid circuit is used. The STC89C52 MCU is adopted in the reseeding system. The clock circuit in this module connects with the controlled reverse phase amplifier through the XTAL1 and XTAL2 pins of the MCU. The MCU was controlled by external oscillator. The value of the capacitor of the oscillator is 30pF and X1 crystal oscillator is 12MHz. After pressing the reset button, the high level was transmitted to the RST terminal, and the components' reset was realized to avoid unnecessary operations. The alarm module detects seed flowing by photoelectric sensors inside the seeding pipe. The work of metering seed device and the seeding pipe are judged by the sending high and low level signals of the sensor. If the sensor continuously sends the low level signal in the set time range, the MCU starts the alarm device. The alarm device adopted the buzzer and LED.

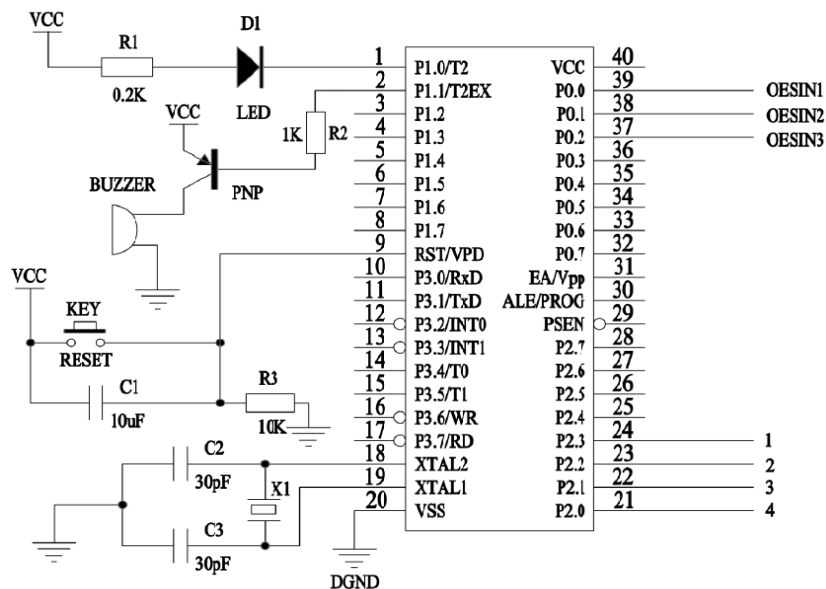

Fig. 5 - Circuit diagram of the control system

The software of automatic reseeding device

The main program flow chart of the detection and control system is shown in Fig. 6. The program executes the initial value setting of the global variable and the start of the photoelectric sensor, and presses the reset key to realize the reset of the system. First, the program is to monitor whether the components are in normal state, initializes the parameter, then receives the detection signal of the photoelectric sensor and

determines whether the seed metering device missed seeding, then it controls the corresponding action of the stepper motor. The action of the stepper motor is controlled by sensors on the main seed metering disc and reseeding disc. The detection device provides the reseeding signal through level of the sensor. In the process of the detection, when there were seeds on the suction hole of the main metering seed disc with the metering seed disc rotating, the laser receptor didn't receive the light signal, the high level was outputted and the stepper motor did not start. When there were no seeds on the suction hole of the main metering seed disc, the low level was outputted, the stepper motor was rationed the set angle for reseeding. At the same time, the next suction hole was detected. If there was no seed on the next suction hole, the stepper motor was controlled to continue turn 18° (*the angle between the two holes*), and the next suction hole was detected. Until the seed was detected on the suction hole, the stepper motor stopped. The seed flowing situation in the seeding pipe is detected by the output signal in the set time. When the seeds normally fell, the sensor outputted a continuous high level signal. When no seeds fell, the sensor outputted a continuous low level signal. If there were no seeds falling in a set time, the LED was lighted and the buzzer started for real-time alarm.

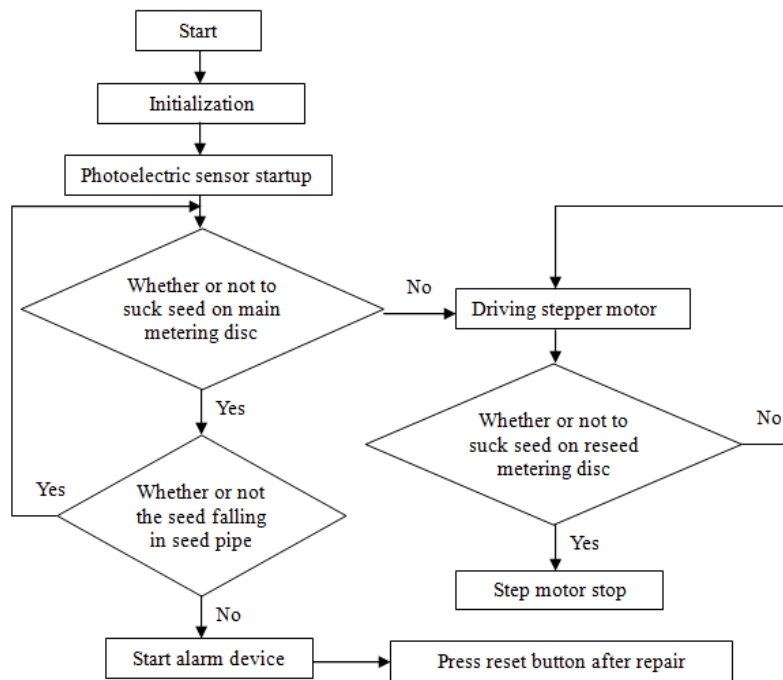

Fig. 6 - The flow chart of main program of the automatic reseeding system

MATERIALS AND METHODS

As shown in Fig.7, the designed air-suction precision corn seed metering device was installed on the JPS-12 automatic test bench to test the performance of the seed metering device. In order to simulate the actual seeds falling into the seedbed, the oil was coated on the seeding area of the seedbed to accept and carry the seeds. The Guiyu No. 1 corn seed was selected in the test. The seeds of the reseeding were coated with red, which is different from the planting seeds.



Fig. 7 - Test bench of the seed metering device performance

The seeding performance of the seed metering device were tested, mainly including: The orthogonal experiment of the influence effect of working factors, and the comparison experiment of the working effect of the seed metering device without the reseeding device and the seed metering device with the reseeding device. The planted seeds were selected as samples during the seedbed belt and metering device stable working. The test results were processed according to the “GB/T6973-2005 single grain (precision) seed metering device test method” (Wu Nan et al, 2016; Yi Shujuan et al, 2014). For the orthogonal experiment, the seed metering device had uninstalled reseeding device. The seeding spaces of the 150 seeds were measured in the each test, and the test was repeated 3 times to get the average value. The comparison test done at the vacuum degree was 4KPa and the speed of the reseeding disc was 15r/min. The seeding spaces of the 150 seeds were measured in each test. Whether the seeding was qualified, it was judged according to the seed spacing. The theory seed spacing was $X_r = 250\text{mm}$ in the test. When X_i was greater than $1.5 X_r$, it was the miss-seeding; When X_i was greater than or equal to $0.5 X_r$ and less than or equal to $1.5 X_r$, it was the qualified one; When X_i was less than $0.5 X_r$, it was over-seeding.

RESULTS

Orthogonal test of the seeding performance

In the orthogonal test, the influencing factors were the vacuum degree A and the rotation speed B of the seeding disks, and the indexes were the qualification rate Q, the over-seeding rate O and the miss-seeding rate M. The factor and level are as shown in table 1.

Table 1

Factor and level table for orthogonal test

Factor	Vacuum degree	Rotating speed of the seed metering disc
	A [kPa]	B[r/min]
1	3.5	15
2	4	20
3	4.5	25

When the seed metering device is operated, the influencing effect of each factor to different operation indexes is different. In order to determine the optimal combination of the factors, the comprehensive weighted score method was adopted to evaluate the orthogonal test results. According to the importance degree of each test index in the test, the weight proportion is determined. The evaluation matrix of the test index is as follows:

$$X = \begin{vmatrix} x_{11} & \dots & x_{1j} \\ \vdots & \ddots & \vdots \\ x_{i1} & \dots & x_{ij} \end{vmatrix} \tag{1}$$

Where, i —test number, j —the three index in test, the qualified rate, over-seeding rate and miss-seeding rate. In the test, the expected change direction of the qualified rate, over-seeding rate and miss-seeding rate is different. In order to make the direction of each index change consistent, the rule of the chosen the score is that if the value is the smaller the better. The test index is converted by formula (2).

$$y_{ij} = \begin{cases} x_{ij}, & j \in U_1 \\ x_{j\max} - x_{ij}, & j \in U_2 \end{cases} \tag{2}$$

where, U_1 -miss-seeding rate and over-seeding rate, U_2 -qualified rate.

According to the formula (2), the magnitude of the index is unified and the dimension is eliminated.

The standardized evaluation matrix for the test index is $Z=(y_{ij})$.

$$Z_{ij} = 100 \times \frac{(y_{ij} - y_{j\min})}{(y_{j\max} - y_{j\min})} \tag{3}$$

where

$$y_{j\min} = \min \{y_{ij} | i = 1, 2, \dots, n\}, y_{j\max} = \max \{y_{ij} | j = 1, 2, \dots, m\}$$

Referring to the relevant agricultural technology requirements and experience (HU Zhichao et al, 2013; Wang Xiaoyan et al, 2013), and considering the importance degree of each index, the weights of each index are: the weights of qualified rate is $w_1=0.6$, the weights of over-seeding rate is $w_2=0.1$, the weights of miss-seeding rate is $w_3=0.3$. The weights are substituted into the formula (3), and the score of each index is as follows:

$$f_i = \sum_{j=1}^m w_j z_{ij} \quad i=1, 2, \dots, n \tag{4}$$

Where, w_i - the weight of each index.

The result of the test, comprehensive weighted score value and the result of the range analysis, is shown in Table 2.

Table 2

Test and analysis results							
No.	Factor			Index value			Comprehensive weighting score value f_i
	A	B	AxB	Qualified rate [%]	Over-seeding rate [%]	Miss-seeding rate [%]	
1	1	1	1	83.11	3.38	13.51	64.4
2	1	2	2	76.58	4.43	18.99	98.0
3	1	3	3	84.71	1.91	13.38	55.3
4	2	1	2	94.96	2.16	2.88	3.9
5	2	2	3	92.11	3.29	4.61	19.1
6	2	3	1	85.19	1.23	13.58	52.4
7	3	1	3	92.81	5.23	1.96	17.0
8	3	2	1	87.12	1.84	11.04	43.1
9	3	3	2	91.52	1.82	6.67	21.0
K1	72.6	28.4	53.3	Sequence of factors: A>B>AxB Optimal combination: A ₂ B ₁			
K2	25.1	53.4	41.0				
K3	27.0	42.9	30.5				
R	47.5	25.0	22.8				

In table 2, it can be obtained: the influence order of the factors is A > B > AxB. When Comprehensive weighting score value was the smallest, the factors combination was the optimal combination. The optimal combination was A₂B₁, it was that the vacuum degree of the gas chamber was 4kPa and the rotating speed of metering seed disc was 15r/min. Under the optimal combination condition, the qualified rate of the seed metering device was 94.96%, the over-seeding rate was 2.16%, and the missing seed rate was 2.88%, and all indexes can meet the technical requirements of seeding performance.

Comparison test of the automatic reseeding performance of the seed metering device

When the vacuum degree of the gas chamber was 4kPa and the rotating speed of metering seed disc was 15r/min, the comparative test of the seeding effect was done on the seed metering device of not install the reseeding device to the seed metering device of the install the reseeding device. The results of the test had shown in Table 3, and the comparison results of the indexes had shown in Figure 8.

Table 3

Comparative test results of air suction seed metering device								
No.	Qualification rate [%]		Over-seeding rate [%]		Miss-seeding rate [%]		Comprehensive weighted score value	
	No reseeding	reseeding	No reseeding	reseeding	No reseeding	reseeding	No reseeding	reseeding
1	92.26	93.24	2.58	4.73	5.16	2.03	35.93	45.25
2	93.88	96.60	2.04	2.72	4.08	0.68	12.45	3.50

No.	Qualification rate [%]		Over-seeding rate [%]		Miss-seeding rate [%]		Comprehensive weighted score value	
	No reseeded	reseeded	No reseeded	reseeded	No reseeded	reseeded	No reseeded	reseeded
3	91.84	96.00	2.72	1.33	5.44	2.67	42.02	16.72
4	90.54	95.92	2.03	3.40	7.43	0.68	63.59	11.05
5	91.95	93.66	2.68	3.52	5.37	2.82	40.43	43.19
6	88.82	90.58	1.97	5.23	9.21	3.92	90.06	80.33
7	91.45	89.61	0.66	4.55	7.89	5.84	52.98	98.11
8	92.11	95.07	5.26	4.23	2.63	0.70	31.73	20.55
9	91.67	93.79	1.92	4.14	6.41	2.07	46.56	39.28
10	88.67	91.56	3.33	4.55	8.00	3.90	89.05	70.09
11	89.33	92.72	8.00	5.30	2.67	1.99	67.63	50.92
12	93.55	95.42	5.16	3.27	1.29	1.31	9.93	18.68
average value	91.34	93.68	3.20	3.91	5.47	2.38	48.53	41.47

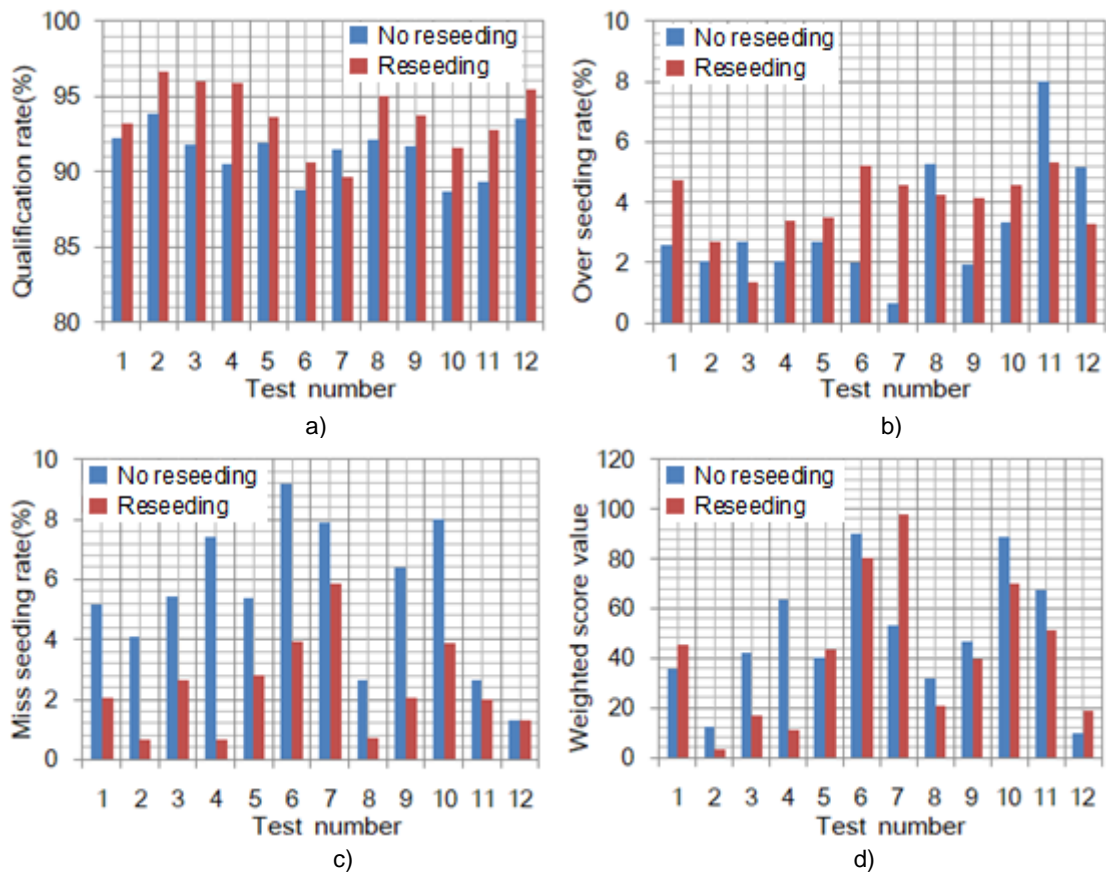

Fig. 8 - Distribution contrast diagram of test results

Table 3 shows that: when the vacuum degree was 4kPa and the rotating speed was 15r/min, when the seed metering device had a reseeded device installed, it was that the highest qualified rate was 96.60%, the maximum over-seeding rate was 5.84%, the minimum comprehensive weighted value was 3.50, the average qualified rate was 93.68%, the average over-seeding rate was 3.91%, the average miss-seeding rate was 2.38%, the comprehensive weighted average value was 41.47; when the seed metering device had no reseeded device installed, the highest qualified rate was 93.88%, the maximum over-seeding rate was 9.21%, the minimum comprehensive weighted score value was 12.45, the average qualified rate was

91.34%, the average over-seeding rate was 3.20%, the average miss-seeding rate was 5.47%, the comprehensive weighted average value was 48.53. When the seed metering device had a reseeding device installed, the qualified rate was increased by 34% and the miss-seeding rate was decreased by 3.09%. As shown in Figure 8, the effect of automatic reseeding device was very significant to improve the seeding performance of the seed metering device. When the automatic replanting device had been installed, the qualified rate was greatly increased, the miss-seeding rate was reduced, and the comprehensive weighted average value was reduced. The influence of the over-seeding rate was not obvious and the analysis shows that the environment conditions of the work were very complicated and the detection system sometimes had some misjudgements, which led to the increase of the over-seeding rate.

CONCLUSIONS

The air-suction corn precision seed metering device with automatic reseeding device was designed. The scheme of automatic reseeding detection and control system was designed. The STC89C52 MCU was chosen as the core of signal processing and control system of the reseeding device. The photoelectric sensors were adopted as reseeding detection element. The design and selection of hardware parts of the detection and control system were finished, and the software program of the system were written.

(1) The orthogonal test of the seed metering device working performance was carried out. The comprehensive weighted score method was adopted to comprehensively evaluate the test indexes, and the comprehensive weighted score value was used to evaluate the seeding effect of the seed metering device. The analysis of the test results showed that: when the vacuum degree was 4kPa and the rotation speed was 15r/min, the seeding performance was the best and the qualified rate was 94.96%, the over-seeding rate was 2.16%, the miss-seeding rate was 2.88%.

(2) When the vacuum degree was 4kPa and the rotation speed was 15r/min, the comparison test was done about the seeding effect of the seed metering device without the reseeding device and the seed metering device with the automatic reseeding device. The result showed that: when the seed metering device had a reseeding device installed, the qualified rate was increased by 2.34% and the miss-seeding rate was decreased by 3.09%, the comprehensive seeding performance was greatly improved. The automatic reseeding device had obvious effect on improving the seeding quality of the air suction corn precision seed metering device. .

ACKNOWLEDGEMENT

The study was supported by the National corn industry system project (CARS-02-29), and the Planning project of Chuzhou University (KJZ06).

REFERENCES

- [1] Cao Dong, (2013), Study on Loss Sowing Monitoring and Early Warning System of Potato Precision Seed metering device [D], *Yangling: North West Agriculture and Forestry University*, Yangling/China;
- [2] Ding Youchun, Wang Xueling, Liao Qingxi, (2014), Method of real-time loss sowing detection for rapeseed precision seed metering device based on time changed window, *Transactions of the Chinese Society of Agricultural engineering (Transactions of the CSAE)*, Vol.30, Issue 24, pp.11-21, Beijing/ China;
- [3] Hu Zhichao, Lü Xiaolian, Peng Baoliang, et al, (2018), Optimization of the Working Performance of Half-Feeding Peanut Picking Device Based on Response Surface Methodology, *INMATEH – Agricultural Engineering*, Vol.54, Issue 1, pp.121-128, Bucharest/ Romania;
- [4] Jae Wan Lee, Young Joo Kim, Seong Il Kang, Joon Yong Kim, Dong Pyo Hong, (2013), The Analysis of the Dynamic Characteristics on Seed Plate of The Vacuum Planters for Precision Sowing, *Applied Mechanics and Materials*, Vol.284-287, pp.968-972, Zurich/Switzerland;
- [5] Li Leixia, Hao Zhiming, Yang Wei et al, (2012), Design of seeding performance detection system for precision seed metering device, *Agricultural Engineering*, Vol. 2, Issue 8, pp.16-19, Beijing/ China;
- [6] Li Ming, Ding Youchun, Liao Qingxi, (2010), Loss sowing detection in field of pneumatic precision seed metering device for rapeseed, *Transactions of the Chinese Society of Agricultural Engineering (Transactions of the CSAE)*, Vol.26, Issue Supp.1, pp.27-31, Beijing/ China;
- [7] Lv X.L, Liu M J, Wang H.O., Hu Z.C, (2012), Research development of peanut seeding technology and equipment on the film, *Chinese Agricultural Mechanization*, Issue1, pp.89-92, Nanjing/ China;

- [8] Shi Song, Zhang Dongxing, Yang Li, Cui Tao, Zhang Rui, Xiaowei, (2014), Design and experiment of pneumatic corn precision seed-metering device with combined holes, *Transactions of the Chinese Society of Agricultural Engineering (Transactions of the CSAE)*, Vol.30, Issue 5, pp.10-18, Beijing/ China;
- [9] Singh T.P., Mane D.M., (2011), Development and laboratory performance of an electronically controlled metering mechanism for okra seed, *AMA-Agricultural Mechanization in Asia Africa & Latin America*, Vol.42, Issue 2, pp.63-69, Tokyo/Japan
- [10] Sun Wei, Wang Guanping, Wu Jianmin, (2016), Design and experiment on loss sowing testing and compensation system of spoon-chain potato seed metering device, *Transactions of the Chinese Society of Agricultural Engineering (Transactions of the CSAE)*, Vol.32, Issue 11, pp.8-15, Beijing/ China;
- [11] Tian Liquan, Wang Jinwu, Tang Han et al, (2016), Design and performance experiment of helix grooved rice seeding device, *Transactions of the Chinese Society for Agricultural Machinery*, Vol.47, Issue 5, pp.46-52, Beijing/ China;
- [12] Wang Lifan, (2015), Single-chip Microcomputer Control Applied on the Corn Seed metering device [D]. *Hebei: Hebei University of Science and Technology*, Hebei/ China;
- [13] Wang Xiaoyan, Liang Jie, Shang Shuqi et al, (2008), Design and experiment of half feeding type peanut picker, *Transactions of the CSAE*, Vol.24, Issue 9, pp.94-98, Beijing/ China;
- [14] Wu Nan, Lin Jing, LI Baofa et al, (2016), Design and test on performance monitoring system of no-tillage planter seed-metering device [J/OL], *Transactions of the Chinese Society for Agricultural Machinery*, Vol.47, Issue Supp., pp.69-75, Beijing/ China
- [15] Yi Shujuan, Liu Yongfen, Wang Chun et al, (2014), Experimental study on the performance of bowl-tray rice precision seed metering device, *International Journal of Agricultural and Biological Engineering*, Vol.7, Issue 1, pp.17-25, Beijing/ China;
- [16] Zhang Xiaodong, Wu Jianmin, Sun Wei, et al, (2013), Design of automatic compensation system for potato planter, *Journal of Gansu agricultural university*, Vol.48, Issue 1, pp.145-149, Lanzhou/ China;
- [17] Zhou Liming, Wang Shumao, Zhang Xiaochao et al, (2012), Seed monitoring system for corn planter based on capacitance signal, *Transactions of the Chinese Society of Agricultural Engineering*, Vol.28, Issue 13, pp.16-21, Beijing/ China;
- [18] Zhu Ruixiang, Ge Shiqiang, Zhai Changyuan et al, (2014), Design and experiment of automatic reseeding device for miss-seeding of crops with large grain, *Transactions of the Chinese Society of Agricultural Engineering*, Vol.30, Issue 21, pp.1-8, Beijing/ China;