

ANALYTICAL INVESTIGATION OF THE INTERACTION OF THE SUNFLOWER STEM WITH THE LATERAL SURFACE OF THE REAPER LIFTER

АНАЛІТИЧНЕ ДОСЛІДЖЕННЯ ВЗАЄМОДІЇ СТЕБЛА СОНЯШНИКУ ІЗ БІЧНОЮ ГРАННЮ ЛІФТЕРА ЖАТКИ

Prof. Ph.D. Eng. Nalobina O.O.¹⁾, Ph.D. Eng. Gerasymchuk O.P.²⁾, Ph.D. Eng. Puts V.S.²⁾,
Ph.D. Eng. Martyniuk V.L.²⁾, Ph.D. Eng. Shovkomyd O.V.²⁾, Vasylychuk N.V.²⁾,
Ph.D. Eng. Bundza O.Z.¹⁾, Ph.D. Eng. Holotiuk M.V.¹⁾, Ph.D. Eng. Serilko D.L.¹⁾

¹⁾National University of Water and Environmental Engineering / Ukraine

²⁾Lutsk National Technical University / Lvivska str., 75, Lutsk, Ukraine;

E-mail: o.z.bundza@nuwm.edu.ua

Keywords: reaper, sunflower, stem, lift, lifting stem, slip, bend

ABSTRACT

The design of a reaper that provides grinding of stems, which eliminates the need for mulcher application, offers the conditions for introducing a new technology of growing No-Till crops in agrarian enterprises. The substantiation method of the analytical model is proposed, which allows to determine the nature of the stem movement on the side surface of the sunflower header elevator in the process of their interaction.

РЕЗЮМЕ

Запропоновано конструкцію жатки, яка забезпечує подрібнення стебел, що усуває необхідність застосування мульчера, створює умови для запровадження нової технології вирощування сільськогосподарських культур No-Till в аграрних підприємствах. Запропоновано методику обґрунтування аналітичної моделі, яка дозволяє встановити характер руху стебла по бічній поверхні ліфтера соняшникової жатки в процесі їхньої взаємодії.

INTRODUCTION

One of the profitable crops in the European Union countries (Martinez-Force E., 2015) is sunflower. The trend of increasing sown areas for this culture is also observed in Ukraine, where over the past ten years the crop area has grown by 60% (Statistical bulletin, 2018). The rapid growth of sunflower production has led to the need to solve the following problems:

- technological: reduction of losses, which are explained by the peculiarities of the structures of the reaper, passing through the threshing apparatus of baskets with long remains of the stems, which leads to the clogging of the deck, reducing its passage section, and as a result, leads to seed damage (Kapustyn, S.A., Kunakov V.P., 2004).

- ecological: loss of microbial activity of the soil, decrease of fertility and accumulation of pathogens due to the fact that there are left rough stems remaining in the fields that do not have time to rot (Lyon D., 1998; Pacini C., Wossink A., Giesen G., Huirne R., 2004).

- Operating: With the introduction of the new No-Till technology, which is gaining in popularity, the life of the tires and caterpillars of agricultural machines is significantly reduced.

Considering the foregoing development of a reaper's design for sunflower harvesting, the need for solving the above-mentioned problems and the analytical methods of research of its individual working bodies represent an important scientific and practical problem.

The traditional oilseed is sunflower, the cultivation of which is characterized by relatively high profitability, export attractiveness. Sunflower plays an important role in the rotation of cereals and is one of the most common crops in the European Union (Martinez-Force E., 2015). In Ukraine, in 2017, sunflower crop area reached 5779 thousand hectares (Statistical bulletin, 2018).

The final harvesting process (Anwar M. T., Gupta C. P., 1990; Burianov M. A., 2011; Kapustyn, S.A., Kunakov V.P., 2004; Kepner R.A., 1978; Klenyn N. Y., Sakun V. A., 1980; Maksoud A., El-Sayed M.A.F., Shalaby G.H., 2009) has a significant impact on the actual yield of sunflower. Indicators that assess the process of harvesting sunflower depend on the technical and constructive parameters of the machines. In particular, the authors Kapustyn, S.A., Kunakov V.P., (2004) established a list of causes of losses during harvesting under the influence of the working bodies of the reaper. In particular, it is established that under

the influence of lifters of sunflower reaper there are losses of free grains, which are explained by the impact on the sunflower stem.

It has been established that the effect of the shield causes the seed of the baskets to be pulled out. Losses in cut-out baskets come from the action of lifters and a reel. When driving a combine, the lifters drove the stems, which leads to the loss of uncut baskets. As field studies have shown, this type of loss is most characteristic of sloping plants.

The research of constructions and basic parameters of sunflower header in order to reduce seed losses is presented in some papers (*Kukhmazov K.Z., Fedorov V.V., 2013; Shaforostov V.D., Makarov S.S., Pohorelov V.N., 2015*).

One of this paper (*Kukhmazov K.Z., Fedorov V.V., 2013*) describes the results of laboratory-field studies of a developed and produced pilot plant for sunflower harvesting, equipped with elastic seed traps. The authors investigate the influence of the angle of inclination of elastic traps and their diameter on the loss of sunflower seeds.

The rational value of the combine working speed is established, provided high productivity and reduction of yield losses are ensured. Advice is given on the rational speed of the combine, which must be within 2 ... 2.5 m/s. It has been established that further increase in speed leads to an increase in sunflower seeds losses.

The results of field trials of the experimental sample of a two-row reaper to the Wintersteiger breeding combine are presented in (*Shaforostov V.D., Makarov S.S., Pohorelov V.N., 2015*). The description of the proposed construction with the description of the basic parameters is given. This design is recommended for use in multi-leaf forms of plants.

A number of valid studies are devoted to the improvement of structures and the establishment of patterns of interaction between a reaper and sunflower harvesters (*Popov M., 2013; Startsev A. S., 2017*).

Popov M. (2013) proposed a design-technological scheme of a screw-shaft, which contains a tubular shaft with two-sided winding. Theoretical studies allowed the author to obtain analytical expressions describing the technological process of interaction of sunflower stems and sunflower baskets with a winding and cutter screw-rotor. The influence of constructive and regime parameters on crop losses is established. On the basis of experimental data, the author obtained regression models that reveal the dependence of seed losses on the winding width, the cutter length provided different angles of inclination of the cutter working part to its base.

Experimental dependence of sunflower seeds losses on the acceleration of the sunflower baskets movement was determined by *Startsev A.S. (2017)*, provided that they hit the tube shaft of the rotor. The author obtained equations that reveal the dependence of seed loss on the acceleration of the baskets due to interaction with the reel without winding and with waving. It has been established that the presence of screw-on screw can reduce the speed of the baskets movement, mitigate the impact and reduce losses.

Makarov S.S. (2007) developed a method for determining the optimal parameters for the process of harvesting sunflower with a combine harvester with screw feed. The basis of the methodology is based on the calculation models of the theory of oscillations. In this work, an estimation of the effect of the screw speed and the size of its step on the intensity of the forced oscillations of sunflower during its interaction with the screw is given.

In order to solve the second and third problems outlined in the introduction, the authors *Dalmist I.S. and others (2013)* investigated the possibility of installing additional cutting devices in sunflower harvesters.

These authors (*Dalmist I.S., Kayisoglu B., Bayhan Y., Ulger P., Toruk F. and Durgut F., 2013*), in order to solve the problem of improving the physico-microbiological structure of the soil, proposed to grind the remains of sunflower plants, remaining in the field, and then to mix them with the soil. In this study, a shredding device that is placed under a combine has been developed. The developed crushing device was tested using three different grinding methods, provided that the speed of the knives was 2443 min⁻¹. The author evaluated the fuel consumption of the machine with different types of chopper. According to the results of experimental researches, recommendations were given regarding the design of the crushing device.

The performed analysis of current research has shown that the development of working bodies of reapers for sunflower harvesting, which ensure the reduction of seed loss and the reduction of the height of the longitudinal stem in the field that remains after the harvesting, is an actual task that has an important scientific and applied value.

The purpose of the work is to establish an analytical link between the parameters of the lifters of the proposed reaper for harvesting sunflower and the nature of the stalk movement.

To achieve the goal, you need to solve the following tasks:

- to carry out an analytical substantiation of the stem movement under the influence of the lateral surface of the header lift;
- to substantiate the mathematical model, which reveals the relationship between the parameters of the elevator and the location of the stem in the field.

MATERIALS AND METHODS

Theoretical studies that reveal the influence of the lateral surface of the lifters of the sunflower harvesters, which are authored and subject to research (Nalobina O.O., 2017, 2018) (Fig. 1), on the stems, are based on the theory of agricultural machines, developed by academician M.N. Letoshnev (Letoshnev M. N., 1934) and the theoretical foundations of analytic geometry (Efymov N.V., 1975).

Analytical studies were carried out on the assumption that the sunflower stems are located on an equal surface and not bent, that is, they have a vertical initial position.

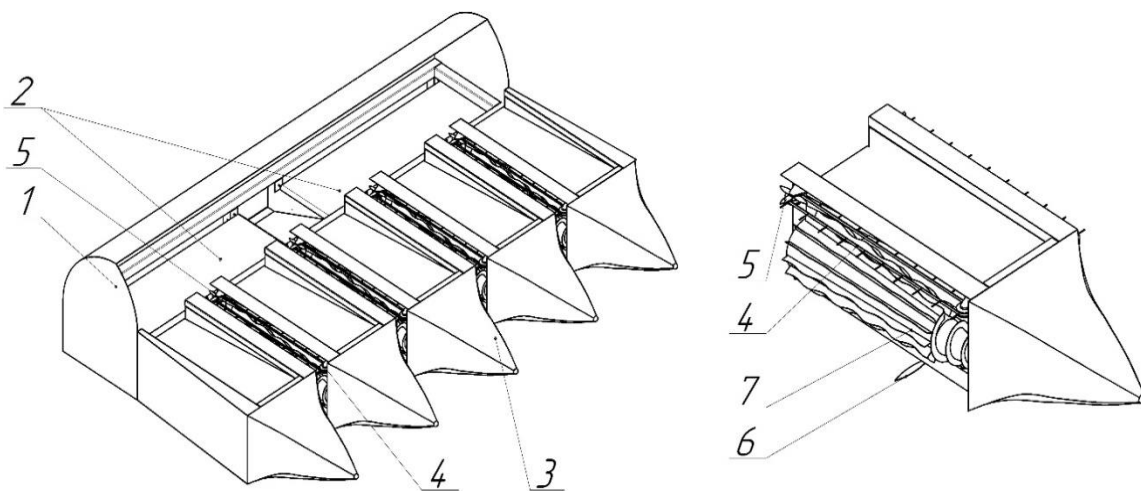

Fig. 1 - Scheme of a reaper

1– frame, 2 – belt conveyors, 3 – lifters, 4 – pass with captures, 5 – knives, 6 – rotating knives, 7 – rotor

The process of harvesting sunflower begins with the effect on the stems of the lateral surface of the reaper lifters. Consider how the interaction of the stems with the elevator is taking place. The regularities of the flow of this process need to be known in order to justify the parameters of the next technological operation - the transfer of stems with passes with grips 4 (Fig.1) in the pylons formed by rotors 7. Consider the moment of contact of the stem with the elevator.

Assume that the stem contact occurs from the side (ab) of the elevator side surface (Fig. 2). The contact point of the stem with the lifter is denoted – C_n . The elevator moves at the speed of a combine with a combine harvester V_z and presses on the stem $O_n C_n$ (Fig. 2). with a lateral surface. The stem, however, deviates in the vertical plane $O_n C_n S_n$ the plane bends and slides along it.

The absolute velocity of the point of contact C_n is denoted V_a , the vector of which has a line of action perpendicular to the stem and lies in the plane of the stem bias $O_0 C_1 C_{np}$; V_r - vector of the relative speed of the point.

The position of the lateral face of the lifter, which affects the stalk, will be determined by the following parameters: h height of the nose, above the ground plane; γ – the angle between its projection onto the plane $x_0 O_0 Y_0$ and the axis Ox ; α – half of an angle exacerbation of the lifter nose.

Friction force F_m between the stem and the side surface of the elevator has an action line that coincides with the action line of the vector of relative velocity V_r and is directed opposite. Action of vector line of common pressure N of the lateral surface of the lifter on the stem is directed perpendicular to the plane $O_n ab$. Friction F between stem and lateral side of lifter has an action line which coincides with vector of

action line of relative velocity \overline{V}_r and directed opposite. The action line of this force is deviated from the normal to the angle φ in the direction of the slope of the stem with the side surface of the elevator.

Under the influence of force F , the resultant of the forces F_m and N , the stem will move. In order to determine the position of the stem, it was necessary to establish the angle dependence θ_1 (Fig.3) on the elevator parameters.

Consider the scheme given in Fig. 3. For further analysis, we introduce the initial coordinate system $x_0O_0y_0z_0$. Axis O_0z_0 passes through the elevator's spout (point a).

The needle moves in such a way that the nose does not touch, in most cases, the stems. This is due to the fact that the stems are located at a distance from the axis x_0O_0 . For example, a stem situated at the distance y_c , from the point O_n (Fig.3). This stem, when moving the lifter slides on it. Slide plane marked $a_1O_nb_1$. Axis x_1 is directed parallel to x_0 . Axis y_1 coincides with the axis y_0 .

Coordinates of any point of the elevator face (a_1b_1) or stems ($x_1y_1z_1$) in the system of coordinates ($x_1O_ny_1z_1$) are connected with coordinates ($x_0y_0z_0$) in the system of coordinates ($x_0O_0y_0z_0$).

This connection can be represented by the following equations:

$$\left. \begin{aligned} x_1 &= x_0, \\ y_1 &= x_0 - y_c, \\ z_1 &= z_0. \end{aligned} \right\} \quad (1)$$

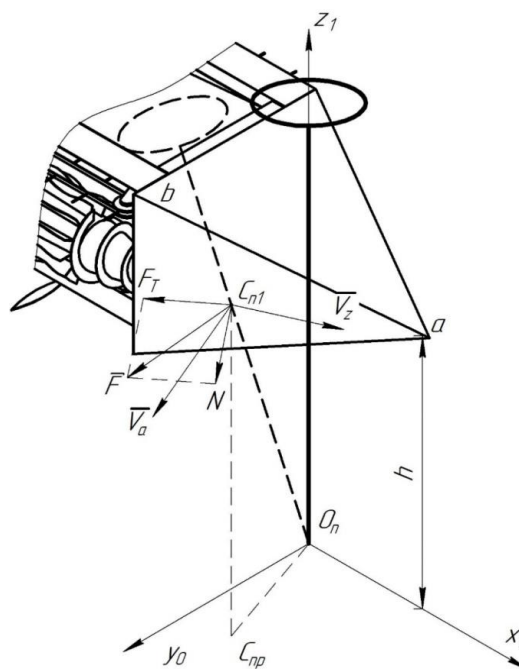

Fig. 2 - Scheme for analysing the interaction of sunflower stem with an lifter

RESULTS

It should be noted that the stem with the base at the point O_n will not interact with the entire lateral surface of the lifter, but only with that part which is located to the left of the point C_{n0} (the starting point of the stem and lifter contact).

In the scheme given in Figure 3, it is seen that distance aC_{n0} determine:

$$aC_{n0} = \frac{y_c}{\sin \alpha} \quad (2)$$

Thus, the stems whose roots are located with the displacement along the y axis does not affect the entire side of the lifter, but only that part that directly brings the stems to the next working body. Sliding plane equation $a_1O_nb_1$ will be written:

$$A_{1K}x_1 + B_{1K}y_1 + C_{1K}z_1 = 0 \tag{3}$$

where A_{1K}, B_{1K}, C_{1K} – coefficients of the equation.

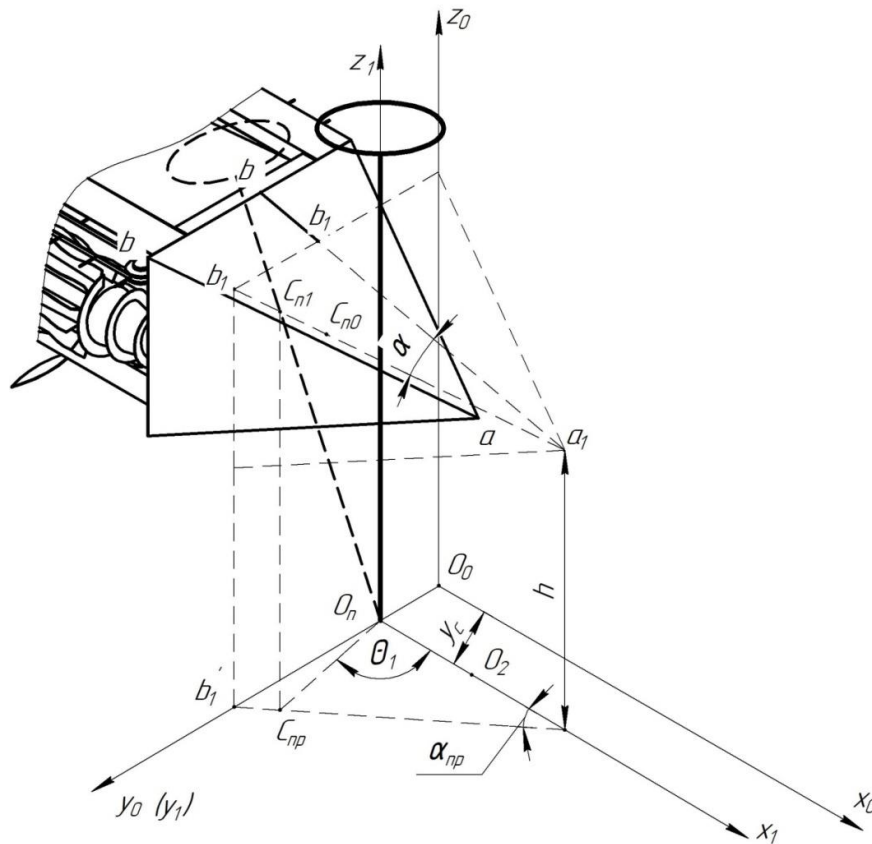

Fig. 3 - A diagram for the analysis of the stem movement

The determination of the coefficient data was carried out considering that:

- for a point C_{n0} :

$$\left. \begin{aligned} x_1 &= x_0, \\ y_1 &= 0, \\ z_1 &= y_c \cdot \sin \gamma \cdot ctg \alpha + h, \end{aligned} \right\} \tag{4}$$

- for a point b :

$$\left. \begin{aligned} x_1 &= l - (b_1 b'_1) \cdot \cos \gamma \cdot ctg \alpha, \\ y_1 &= (b_1 b'_1) - y_c, \\ z_1 &= h + (b_1 b'_1 - y_c) \cdot \sin \gamma \cdot ctg \alpha, \end{aligned} \right\} \tag{5}$$

where l - move point C_0 in the system of coordinates $x_1 O_{11} y_1 z_1$.

Then the coefficients of equation (3) will look like:

$$\left. \begin{aligned} A_{K1} &= y_c \cdot \sin \gamma \cdot ctg \alpha + h, \\ B_{K1} &= \left(l \frac{(b_1 b'_1) - 2y_c \cdot \sin \gamma + h \cdot \cos \gamma}{(b_1 b'_1) - l} \right) \cdot ctg \alpha + y_c \cdot \sin \gamma \cdot \cos \gamma \cdot ctg^2 \alpha, \\ C_{K1} &= -l. \end{aligned} \right\} \tag{6}$$

The displacement l depends on the displacement of the spout – L (fig. 4). Consider the scheme given in Fig.4, where we see two positions of the side surface of the elevator: ab and a_1b_1 – starting, which corresponds to the point of contact C_{n0} of stems and the following position which is characterized by the displacement of the elevator by the value of l and the displacement of the point C_{n0} in position C_{n1} .

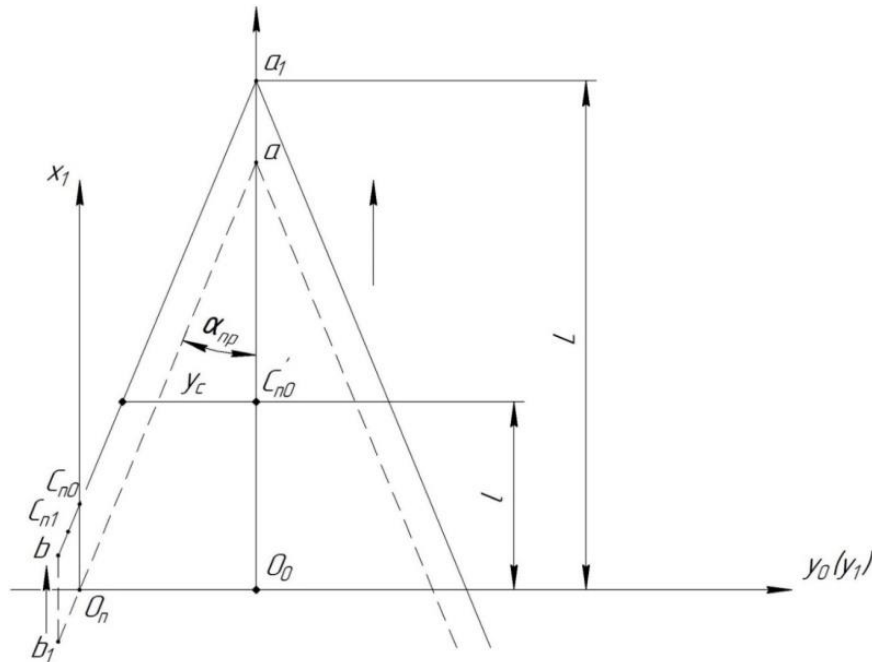

Fig. 4 - Top view of the lifter

In the scheme we see:

$$\left. \begin{aligned} aa_1 = C_{n0}C_{n0}' = l, \\ L = l + y_c \cdot ctg\alpha_{np}, \end{aligned} \right\} \quad (7)$$

where α_{np} – projection angle α on the surface $x_0O_0y_0$.

Based on the above we have:

$$l = L - y_c \cdot \cos\gamma \cdot ctg\alpha_{np} \quad (8)$$

As noted earlier, the stem slides along the side of the elevator and bends in the vertical plane. This plane passes for a stem with a root located in point O_n , through the axis O_nz_1 and point of C_n drop. This surface $C_nO_nC_{n0}$ deflected from the plane $y_1O_nz_1$ at some angle, which we will denote θ_1 (fig. 3).

Flat equation plane:

$$A_{1B}x_1 + B_{1B}y_1 = 0. \quad (9)$$

Points coordinate $C_{n1}(x_1; y_1)$:

$$x_1 = l - (C_{n0}C_{n1}) \cdot \cos\gamma \cdot \cos\alpha,$$

$$y_1 = (C_{n0}C_{n1}) \cdot \sin\alpha.$$

$$\text{Distance } C_{n0}C_{n1} \text{ will be defined: } C_{n0}C_{n1} = (a_1C_{n1}) - \frac{y_c}{\sin\alpha}.$$

Substituting these coordinates and solving the equation of type $\frac{H}{L}x + \frac{K}{L}y + z = 0$ (Efymov N.V.,

1975) will define coordinates:

$$\left. \begin{aligned} A_{1B} &= (a_1 C_{II1}) \cdot \sin \alpha - y_c, \\ B_{1B} &= (a_1 C_{II1}) \cdot \cos \gamma \cdot \sin \alpha - y_c \cdot \cos \gamma \cdot ctg \alpha - (L - y_c \cdot \cos \gamma \cdot ctg \alpha) \end{aligned} \right\} \quad (10)$$

Let's record the equation of the slip plane and the plane of the bend in the general case for the k-th stem. To do this, we will introduce the notation: y_{ck} – distance from the point O_0 to the basis k stems along the axis y_k ;

- l_i – way of moving the nose of the elevator in the i-th coordinate system
- x_{ck} – distance from the point O_0 to the basis k stems along the axis x_k (for example, point O_2 fig.3).

In view of the above, we obtain the equation of the sliding and bending planes for the k-th stem.

Sliding plane equation:

$$A_{kk} x_k + B_{kk} y_k + C_{kk} z_k = 0, \quad (11)$$

where the coefficients are determined by dependencies:

$$\left. \begin{aligned} A_{kk} &= h + y_{ck} \cdot \sin \gamma \cdot ctg \alpha, \\ B_{kk} &= - \left[\frac{1}{n} (h + t) \cdot (l_k - n \cdot \cos \gamma \cdot ctg \alpha) - l_k (h + m + t) \right], \\ C_{kk} &= -(L - y_{ck} \cdot \cos \gamma \cdot ctg \alpha - x_{ck}). \end{aligned} \right\} \quad (12)$$

where $n = (b_1 b_1') - y_{ck}$, $m = (b_1 b_1') \cdot \sin \gamma \cdot ctg \alpha$, $t = y_{ck} \cdot \sin \gamma \cdot ctg \alpha$.

Trace l_k we deduct from the moment of touch of the stem with the lateral face of the elevator.

The flatness plane of the bend in the general form will be written down as:

$$A_{kB} x_k + B_{kB} = 0, \quad (13)$$

where coefficients are defined:

$$\left. \begin{aligned} A_{kB} &= (a C_{IIk}) \cdot \sin \alpha - y_{ck}, \\ B_{kB} &= (a C_{IIk}) \cdot \cos \gamma \cdot \cos \alpha - y_{ck} \cdot \cos \gamma \cdot ctg \alpha - l_k, \end{aligned} \right\} \quad (14)$$

where $l_k = L - y_{ck} \cdot \cos \gamma \cdot ctg \alpha$.

In order to obtain a mathematical model that reveals the legality of the movement of the k-th stem by lifter $a C_k = f(l)$ we deduce the equation of the force line F_T and N and their resulting point F .

For this purpose:

Based on the laws of analytic geometry (Efymov N.V., 1975) simultaneously considering equations (3) and (9), expressions have been obtained to determine the guiding parameters l_{k1} , m_{k1} , n_{k1} (Efymov N.V., 1975);

Substituting the received expressions into the equations of the canonical form of the intersection of the slip and bending planes, we obtain the equations of the line of their intersection. It should be noted that this equation can be taken from the equation of the stem on which at the moment the lateral side of the elevator acts.

The resulting equation of the intersection of the sliding and bending planes in the general form (for k^{th} stem) has the form:

$$\frac{x_k}{-C_{kk} \cdot B_{kB}} = \frac{y_k}{C_{kk} \cdot A_{kB}} = \frac{z_k}{-A_{kk} \cdot B_{kB} - B_{kk} \cdot A_{kB}} \quad (15)$$

Similarly, determining the directional parameters of the action lines of the vectors of the absolute and relative velocities of the point C_{nk} we got the equation of their action lines. As indicated above, the equation of the action line of the relative velocity will be described as well as the action line of the frictional force F_T and they will look like:

$$\frac{x_k - x_{C_{nk}}}{l_{kF_T}} = \frac{y_k - y_{C_{nk}}}{m_{kF_T}} = \frac{z_k - z_{C_{nk}}}{n_{kF_T}} \tag{16}$$

where $l_{kF_T}, m_{kF_T}, n_{kF_T}$ – guiding parameters of the action line of the friction force.

The equation in the canonical form and the action line of the force of normal pressure, N , which is perpendicular to the sliding plane, passes through the point C_{nk} . Similarly, it was obtained using the coordinates of the vectors (a detailed description is not provided in the article):

$$\frac{x_k - x_{C_{nk}}}{l_{kN}} = \frac{y_k - y_{C_{nk}}}{m_{kN}} = \frac{z_k - z_{C_{nk}}}{n_{kN}} \tag{17}$$

where l_{kN}, m_{kN}, n_{kN} – guiding parameters of the action line of the force of pressure.

The angle between the planes in which the force acts F_T and N equals angle ϑ friction between the stem and the surface of the lifter. According to the formula known from *Efymov N.V. (1975)*, we obtain:

$$\cos \vartheta = \frac{l_{kN} \cdot l_{kF_T} + m_{kN} \cdot m_{kF_T} + n_{kN} \cdot n_{kF_T}}{\sqrt{(l_{kN}^2 + m_{kN}^2 + n_{kN}^2) \cdot (l_{kF_T}^2 + m_{kF_T}^2 + n_{kF_T}^2)}} \tag{18}$$

The mathematical model (18) reveals the relationship between the parameters:

- lifter: $\gamma, \alpha, (b_1, b_1')$;
- its installation: α, h ;
- parameters of the position of the stems $y_{ck}, x_{ck}, \theta_k, \alpha C_{nk}$.

After the stem is removed from the lifter, it falls under the influence of the following working bodies (Fig. 1).

The distance between the adjacent surfaces of the rotors must be set in such a way as to prevent clogging. For that, stem should not be strongly deflected by the lateral faces on which they slip. This makes it impossible to cross them. The number of stems coming from the lifter will depend on the density of sunflower stems on the field, that is, the parameters y_{ci} and x_{ci} , which are included in the above-mentioned dependencies.

In order to determine the influence of the angle of inclination of the elevator lateral side, the angle of exacerbation of the elevator and the height of the installation of its nose over the surface of the soil on the magnitude of the angle between the lines of force F_T and N , depend on the conditions is constructed: $\alpha=5^\circ - 25^\circ$ and $h_1=600$ mm i $h_2=800$ mm.

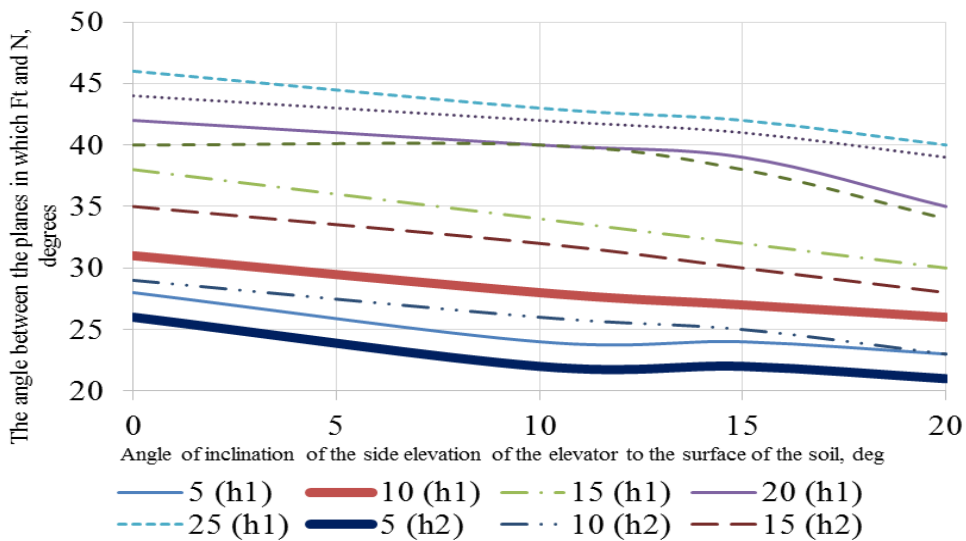

Fig. 5 - Dependence of the angle between the lines of force F_T and N and the angle of inclination of lateral side of the lifter

The performed analytical analysis gives grounds to assert that the process of interaction of the stems with the lateral side of the lifter depends on its constructive parameters, namely, the angle α and the lengths of the ab side and the technological parameters: the height of the installation and the angle of inclination to the surface of the field.

The analysis methodology of the analytical model, which allowed to determine the nature of the stem movement along the lateral sides of the sunflower header lifter in the process of their interaction, was obtained. This technique was used in the process of designing and further manufacturing a reaper for sunflower harvesting (fig. 1, 6). The lifters of the header have been adjusted in relation to the basic design and can be used to justify the parameters of lifters, in particular for the design of the header.

The resulting equality, considering the previous formulas, establishes the relationship between the parameters $h, s_i, \alpha, \beta_0, e_{x_i}, e_{y_i}, b, \varphi, \psi, AM_i$.

Having solved this equation, one can determine the pattern of movement of the stem along the bar, namely, the function $AM_i=f(s_i)$ for other known parameters.

CONCLUSIONS

1. The method of substantiation of the analytical model is proposed, which allows to determine the nature of the stem movement on the lateral surface of the sunflower header elevator in the process of their interaction.

2. It is established that the angle between the planes in which the force acts F_T and N , which equals angle ν friction between the stalk and the surface of the lifter decreases with a decrease in the angle α aggravation of its faces, increasing angle γ the slope of the lateral face of the lifter to the ground and the elevation of the elevator lifting height h .

3. It is recommended to take the angle of the elevator 40° (half of the angle $\alpha \leq 20^\circ$).

REFERENCES

- [1] Anwar M.T., Gupta C. P., (1990), Performance evaluation of chick pea thresher in Pakistan, *Agricultural Mechanization in Asia, Africa and Latin America*, Vol. 21(3), pp. 23-28, Phnom Penh / Cambodia;
- [2] Burianov M. A., (2011), Investigation of the interaction between the ear of a plant and the teeth of a single-drum hinged reaper when harvesting crops. (Исследование взаимодействия колоса растения с зубьями однобарабанной навесной на комбайн жаткой при уборке зерновых культур очесом), *Scientific Journal KubHAU*, No. 67, pp. 1–10, Kuban / Russia;
- [3] Dalmist I.S., Kayisoglu B., Bayhan Y., Ulger P., Toruk F. and Durgut F., (2013), Development of a chopper unit for chopping of sunflower stalk during harvesting by combine harvester, *Bulgarian Journal of Agricultural Science*, Vol. 19, (no.5), pp. 1148-1154, Sofia / Bulgaria;
- [4] Efymov N.V., (1975), *A short course of analytic geometry (Краткий курс аналитической геометрии)*, Moscow / Russia;
- [5] Kapustyn, S.A., Kunakov V.P., (2004), *Analysis of losses during sunflower harvesting (Аналіз втрат при збирання соняшнику)*, Vestnyk THTU, no.3, pp. 773–778, Ternopil / Ukraine;
- [6] Kerper R.A., (1978), *Principles of farm machinery 3rd edition*, Avi Pub Co, ISBN:087055252X, 527 p., Westport / Australia;
- [7] Klenyn N. Y., Sakun V. A., (1980), *Agricultural and meliorative machines: Elements of the theory of work processes, calculation of adjusting parameters and operating modes (Сельскохозяйственные и мелиоративные машины: Элементы теории рабочих процессов, расчет регулировочных параметров и режимов работы)*, Kolos, 671 p., Moscow / Russia;
- [8] Kukhmazov K.Z., Fedorov V.V., (2013), *Reduction of losses of sunflower seeds during harvesting (Снижение потерь семян подсолнечника при уборке)*, Nyva Povolzhia, no. 2, pp. 83–88, Penza / Russia;
- [9] Letoshnev M.N., (1934), *Agricultural machines. Theory and calculation. (Сельскохозяйственные машины. Теория и расчет)*, Moscow / Russia;
- [10] Lyon D., (1998), Sunflower residue weight and ground cover loss during summer fallow, *Journal of Soil and Water Conservation*, no. 53, ISSN: 1941-3300, pp. 71–73, Ankeny / USA;
- [11] Makarov S.S., (2007), Determination of the optimal operating modes of the device with screw feeding of stems for harvesting sunflower (Определение оптимальных режимов работы приспособления

- со шнековой подачей стеблей для уборки подсолнечника), *Oilseeds. Scientific and Technical Bulletin of the All-Russian Research Institute of Oilseeds (Масличные культуры. Научно-технический бюллетень всероссийского научно-исследовательского института масличных культур)*, Vol. 1., pp. 119–123, Moscow / Russia;
- [12] Maksoud A., El-Sayed M.A.F., Shalaby G.H., (2009), Modifying and testing a header system for cereal crop harvester to be suitable for sunflower harvesting, *Egyptian journal of agricultural research*, ISSN: 1110-6336, Cairo / Egypt;
- [13] Martinez-Force E., (2015), *Sunflower: Chemistry, Production, Processing, and Utilization*, Presented at Urbana, Illinois / USA;
- [14] Nalobina O., Markova O., Vasylichuk N., (2016), Application of morphological analysis and synthesis for the design of sunflower harvesting machines. WSEI scientific notebooks. Transport and IT series (Zastosowanie analizy i syntezy morfologicznej do projektowania maszyn do zbioru słonecznika. Zeszyty naukowe WSEI. Seria Transport i informatyka), Vol. 6 (1), *Lublin nnovatio Press Scientific Publisher of the University of Economics and Innovation (Lublin nnovatio Press Wydawnictwo Naukowe Wyższej Szkoły Ekonomii i Innowacji)*, pp. 45-52, Lublin / Poland;
- [15] Nalobina O.O., (2017), *Sunflower harvesting knife (Жатка для збирання соняшнику)*. Patent No. 118144, Rivne / Ukraine;
- [16] Pacini C., Wossink A., Giesen G., Huirne R., (2004), Ecological-economic modelling to support multi-objective policy making: a farming systems approach implemented for Tuscany, *Agriculture, ecosystems & Environment*, Vol. 102, ISSN: 0167-8809, pp. 349-364, Amsterdam / The Netherlands;5
- [17] Popov M., (2013), *Improvement of the technological process of sunflower harvesting by substantiating the structural and regime parameters of the auger-reel (Совершенствование технологического процесса уборки подсолнечника обоснованием конструктивных и режимных параметров шнека-мотовила)*, PhD dissertation, Saratov Agrarian State University, Saratov / Russia;
- [18] Shaforostov V.D., Makarov S.S., Pohorelov V.N., (2015), Header for a sunflower harvesting machine (Жатка к селекционному комбайну для уборки подсолнечника), *Oilseeds. Scientific and Technical Bulletin of the All-Russian Research Institute of Oilseeds (Масличные культуры. Научно-технический бюллетень всероссийского научно-исследовательского института масличных культур)*, Vol. 2, pp. 103–105, Moscow / Russia;
- [19] Startsev A.S., (2017), Experimental-theoretical justification of the construction and diameter of the tube shaft of auger-reel scraper for harvesting sunflower (Экспериментально-теоретическое обоснование конструкции и диаметра трубного вала шнека-мотовила жатки для уборки подсолнечника), *Proceedings of the Orenburg State Agrarian University (Известия оренбургского государственного аграрного университета)*, Vol. 1, pp. 70–74, Orenburg / Russia;
- [20] Statistical bulletin, (2018), «*Harvesting of crops*» (Статистичний бюлетень (2018 р.) «Збирання врожаю сільськогосподарських культур»), URL: http://www.ukrstat.gov.ua/druk/publicat/Arhiv_u/07/Arch_zv_bl.htm.