

Multi-featured Food Cart

Prof. Romeo M. De Asis¹, Jeff Clifford Aniñon², Alexander Bayron³, ZebarCambare Jr.⁴,
Reymark Dagupan⁵, Julius Angelou Echeveria⁶, Donald Jay Gamalo⁷, Erick Zephaniah
Ontong⁸

1(BS Electrical Technology and Management, University of Science and Technology of Southern Philippines/College of
Technology, and Lapasan, Cagayan de Oro City)

Abstract:

The study focuses on the design, development, and evaluation of a multi-featured food cart as its application on the street to facilitate the sale and marketing of street food to people from the local pedestrian traffic. In particular, the research aimed to design and develop a Multi-featured Food Cart which has its own electrical system; lighting system, convenience outlets, coin operated outlet, sound system, electric stove and an improve structures; foldable and extendable roof and collapsible tables.

The acceptability of the Multi-featured Food Cart is evaluated in terms of its aesthetic, functionality, reliability and safety. The results revealed that the design and development of the Multi-featured Food Cart is operational with its electrical features and structural features. Based on the analytical data presented, the result revealed that the Multi-featured Food Cart is highly acceptable in terms of aesthetic, functionality, reliability and safety. In addition, an improvement on some technical field on mechanical methods for better structure is necessary to attain effective implementation of the carts mobility on the community.

Keywords — multi-featured, food cart, aesthetic, functionality, reliability, safety.

I. INTRODUCTION

A food cart is a mobile kitchen that is set up on the street to facilitate the sale and marketing of street food to people from the local pedestrian traffic. Food carts are often found in large cities throughout the world and can be found selling food of just about any variety. The earliest food carts came into being at the time of the early Greek and Roman civilizations. Carts have the distinct advantage of being able to be moved to a location that has productive sales, as well as transporting goods to/from storage to the place chosen from which to trade. In the 21st century, innovations have included modular designed carts made with stainless steel, fiber reinforced plastic and aluminum. Some have been developed with the ability to be driven by themselves. Some food carts are associated with restaurants. Most of the food served from the cart is the same as the food in the restaurant[1].

The food cart boom sparked the appetite of hungry customers, and ignited brilliant entrepreneurs into a revolutionary idea that would take the mobile food industry to a whole new level. It was time to upgrade both the food and the wheels. It is fact that the food cart business is becoming popular among the entrepreneur of the Philippines because it is easily manageable and easy to set up. [2]. At present, the market has a variety of food carts, but it is mainly used for food processing which makes the function cannot meet the needs of the market.

The researchers had consulted with the Food Innovation Center in the University of Science and Technology of Southern Philippines to determine the proper delivering and displaying of food, to know its safety to human health, and to broaden ones knowledge in terms of food handling. According to the Northern Mindanao Food Innovation Center manager Ms.Cristy Marie V. Alsado, placing food carts outdoors were apparently

not acceptable due to it available microorganisms that may present in delivering food. For example; like the vendors outside the said university marketing their food without an awareness of the illnesses that may take by the customers like through the mufflers of the cars and the sauce was just being dipped and poured by everyone that was eating, and etc., which may contaminate the food or just become harmful to human health. Ms. Alsado told the researchers what must be the things to be done for the prevention of those problems that is safe for human consumption. Also, studies have raised serious concerns on the dangerous street foods may bring due being exposed in the vending environments. Street food vendors usually target high human traffic areas for the display of their products to enhance sales. Street food vending is a common site in such areas as major street corners, industrial/construction sites, bus/train terminals, public places and school compounds [3]. The vending units are either mobile or stationary using open or protected crude structures such as push carts, display wooden tables, aluminum trays or bowls or chop bars [4]. The FIC manager recommended to the researchers that the design of the proposed food cart must have its own cooking facility that can be covered when not in use, a freezing facility so that it maintains the quality of the food to keep fresh whenever no one ordered, and a separated trash can for proper sanitation. The manager also stated a separated storage for raw materials to be cooked, storage for preparation like utensils use for cooking, a place for cooking section, and a place for displaying of the food. According to Ms. Alsado utensils that are used in food marketing must be disposable and the sauce must be properly dispensed or may be pre-packed so that consumers may not dip in a sauce in one place at a time. Possibly, food cart must be place indoors to be able to minimize those problem encountered outdoors.

The researchers found out that the weakness of other existing food carts was the ability to catch the eye of the customers. The disadvantages of the design were the mechanism of the cart that can't produce a table out of its structure. In terms of health assurance, most food cart doesn't use properly dispense sauce and the food are displayed

without cover from dust or any elements that may contaminate it. Also there are no ventilation or exhaust fan that is attached to the cart which it can remove moisture out of the cooking process. The researchers has taken all the weaknesses and disadvantages of the existing food carts into consideration in order to make the "Multi-featured Food Cart" which has its own electrical system and an improved structure to add more functions and appeal of the food cart.

Statement of the Problem

The main purpose of this study is to design and develop a multi-featured food cart. Specifically, the study attempts to answer the following issues:

1. What are the considerations in the design of the Multi-featured Food Cart?
2. What strategies in the development of the Multi-featured Food Cart?
3. What are the parameters used to assess the acceptability of the Multi-featured Food Cart?

Objectives of the Study

The main objective is to come up with a Multi-featured Food Cart.

The specific objectives of the study are as follow:

1. To design the Electrically Controlled Bearing Puller
2. To develop the Electrically Controlled Bearing Puller.
3. To evaluate the project in terms of predetermined parameters.

Conceptual Framework of the Study

Figure 1 below shows the conceptual framework of the research.

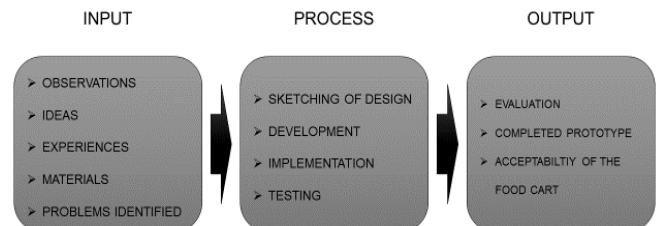

Figure 1 Conceptual Framework of the Study

Through observations and experience the researchers has identified a problem, which is the about the commonly used food carts in the Philippines with respects to their aesthetic and functionality. Through data gathering, the researchers had come up with an idea, which is to develop and construct a Multi-featured Food Cart. The researchers conducted several research and data gatherings that gave further knowledge and scheme on how to execute the experiment properly.

Through books and internet access, the researchers gathered information about the possibility of developing the multi-featured food cart which has its own electrical system and an improved structure, by the help of some related review of literature. With the help of Computer Aided Design System, they sketched the possible appropriate design of the Multi-featured Food. After implementing the information gathered, formulation of plans and design Testing takes place. Researchers were able to construct procedures which are appropriate to follow for the experiment.

Evaluation was the last step after the prototype is completed, for the researchers evaluated the acceptability of the Multi-featured Food Cart in terms of aesthetic, functionality, reliability and safety.

Significance of the Study

The availability of Multi-featured food cart is very helpful because many the usual existing. It can also be more safety and being protected or unlikely cause of danger because of its encasing glass where food will be displayed. Because of the inputs featured in the Cart is very convenient. The product was built to easily clean stains and dirt. Considering of its capability to work undelay, it has a four caster wheels that even if it has heavy load it can run smoothly and it is hitch free. In fact a Multi-featured food cart helps the owner get more income and might become popular.

The study generally could contribute positive impact on the Philippine's economy.

To the entrepreneur, whose business is in line with food cart franchising, this could be a good opportunity for them to increase income.

To different communities, both urban and rural where the number of people who doesn't gain income is high, the study is beneficial to them since food cart in this study is affordable so it could be a great source of income.

To the University of Science and Technology of Southern Philippines community as institution advocating science and technology education, the study could be great help in promoting technological advancement for entrepreneurial development.

Furthermore, this study will serve as baseline information for other researchers who wishes to contribute in the economic development in the country.

Scope and Limitation of the Study

The study is about Multi-featured food cart, focusing only on the limits of designing and developing it. The researchers only put necessary items in order to attain its functionality, safety and reliability. The study was conducted at University of Science and Technology of Southern Philippines. The Multi-featured Food Cart is the actual design and used available materials.

The researchers limit the study specifically to the following:

1. The structural feature of the Multi-featured Food Cart is the following:

- Foldable and Extendable Roof
- Collapsible Tables

2. The Multi-featured food cart will have two separate electrical systems shown below as follows:

- Primary Electrical System

The agreement between the seller and nearby household for supplying the Secondary Electrical System will be excluded from this study.

3. The materials that will be used by the customer will be disposable (spoon, fork, plate, cup, etc.).

4. Additional features of the Multi-feature food cart are as follows:

- Fire Extinguisher
- Lapel

- Trash Bin
- Chairs

5. The Multi-featured Food Cart is suitable for places like school campuses, parks and other infrastructure grounds that are not exposed to the smokes from vehicles.

As referred to the Northern Mindanao Food Innovation Center manager, Ms. Cristy Marie V. Alsado, it is not suitable for food carts in places such as highways, public roads and other places with the environment full of contaminations like smoke and dirt.

II. RELATED WORKS

In this chapter a brief review of the literature pertaining to the scope of the work is presented.

A food cart is a mobile kitchen that is set up on the street to facilitate the sale and marketing of street food to people from the local pedestrian traffic. Carts have been used for more than thousands of years ago. They used carts in transporting goods from storage to the place chosen from which to trade.

Foreign Literature

The earliest food carts came into being at the time of the early Greek and Roman civilizations. Carts have the distinct advantage of being able to be moved should a location not be productive in sales, as well as transporting goods to/from storage to the place chosen from which to trade [5]. In the 21st century, innovations have included modular designed carts made with stainless steel, fiber reinforced plastic and aluminum. Some have been developed with the ability to be driven by themselves [6]. Some food carts are associated with restaurants. Most of the food served from the cart is the same as the food in the restaurant.

Around 1870, German immigrant Charles Feltman opened the first Coney Island hot dog stand by selling warm dachshund sausages in a milk roll. As far as the portable carts that we know today, in the mid-1890s sausage vendors would sell their

products outside of student dorms at eastern universities [7]. The portable carts that they used where commonly referred to as “dog wagons”, and are often cited as the precursor to what is now known as the modern day hot dog cart. As far as what we now know as the modern day hot dog cart, in 1936 Oscar Mayer rolled out the first hot dog street vending cart and called it the “Wiener Mobile”. Along with the “new breed of lunch truck” being “aggressively gourmet” and “techsavvy,” many are also “politically correct” [8]. Beyond the recent economic downturn that helped spur the food truck movement and their unique use of web technologies to appeal to broader socio-economic classes, gourmet food trucks can also probably attribute some of their success to the way they conduct business locally, politically, and aesthetically. Sidney Mintz reminisces about the days in which the basic foods people consumed never “came from more than perhaps a dozen miles away” [9]. “Many people are beginning to bemoan the loss of a rich, highly personal culinary past,” and are seeking alternatives in which they can be more sustainable as well as support organic, local food sources.

It is of interest to note that the first patent for hot dog carts predates the “Wiener Mobile”. In 1926, Frances E. Coffey came up with blue prints for what is remarkably similar in design to the modern hot dog vending cart. The cart had provisions for an ice box, cooking plate, steam table, and several storage bins.

Local Literature

Street foods are enjoying increasing patronage due to industrialization which is forcing many city dwellers to eat their major daily meals out of home [10]. Street food vending is a common feature of most cities and towns in developing countries [11]. Aside provision of ready-made instant meals at relatively inexpensive prices, teeming urban dwellers are attached to street foods because of its gustatory attributes. These attributes are linked to the culinary prowess of the vendors [12].

The significant contribution of street foods to nutrition and food security for millions of practitioners along the chain, ambulant fish balls

vendors are a familiar sight all over the Philippines [13].

From the humblest neighbourhood to the posh business districts, their customers range from the barefoot toddlers in slum areas to the yuppies in Makati City. The “kitchen in wheels” includes a portable liquefied petroleum gas (LPG) tank and a small gas burner on which the fish balls are deep fried. Customers take a bamboo skewer from the cart (seen tied on the arm of the umbrella) with which they pierce the hot fish balls as they brown in oil. The wide-necked bottles contain the different sauces for the fish balls—sweet, sweet and sour, and spicy—into which the skewered fish balls are dipped [15].

Food cart history has also made its mark in some of the country’s top schools, enticing even non-students into becoming regular customers. The University of the Philippines (UP) in Diliman has a proud history of its “isaw” (chicken intestines) and the “arstokarts”, so named as a pun on the popular Aristocrat restaurant. De La Salle University (DLSU) Taft Avenue has the Agno food court, where food carts line a small alley [16].

However, these early food carts couldn’t cut it in upscale malls and train stations. Despite their rickety wooden charm, it was hard for customers to look past their makeshift carts and the promise of hepatitis lurking in their paint chipped surfaces. So, the food cart changed with the times. The era of prefabricated, customizable, and sparkling clean food carts began. These all-stainless steel models soon brought street food like fish balls and shawarma into elite, air-conditioned buildings and malls [17].

III. METHODOLOGY

Design

In technical research, prototype lay-outing must be observed thoroughly because it discusses all the details of what does the actual research look like and to achieve the objectives of the study. There are considerations that should be followed in constructing a prototype lay-out. First the design and functionality of the device, it should be

presentable and safe to operate to ensure the given sample is fully operated, also the accuracy of the prototype to assure users that the credibility of the device is great. The researcher would base his prototype model on its aspect to insure if it is successfully done or not.

The researchers used Computer Aided Design System to sketch the possible appropriate design of the Multi-featured Food in which the researchers come up after several discussions, observations, arguments and gathering of ideas to have a Multi-Featured Food Cart that is much presentable and is safe to operate. The researchers focused the designing on the aesthetic, functionality, reliability and safety of the Multi-featured Food Cart.

Figures 2 below shows the conceptual design of the Multi-Featured Food Cart, it can change positions of the roof of the Multi-featured Food Cart.

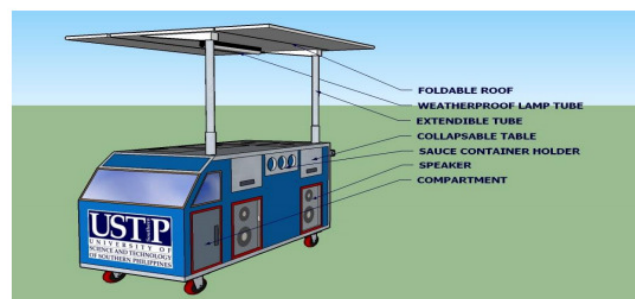

Figure 2 Conceptual Design of the Multi-Featured Food Cart

Figure 3 shows the internal view of the multi-featured food cart; it is composed of a 12V lead battery, battery charger, power inverter, amplifier, electric stove, propane tank, gas stove, cooler box, utensils, and fire extinguisher which are all placed on each designated compartments.



Figure 3 Internal View of the Multi-Featured Food Cart

Figure 4 shows the Worms-Eye View of the Multi-Featured Food Cart showing the five peso coin slot, timer, weatherproof outlet, electrical cord and single phase circuit breaker.

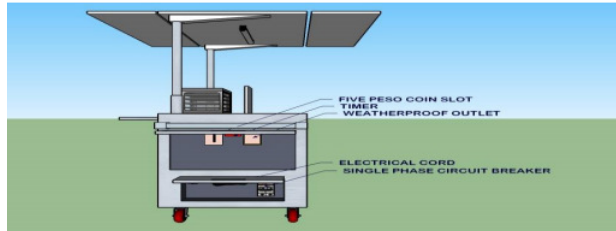

Figure 4 Worms-Eye View of the Multi-Featured Food Cart

Block Diagram

The researcher designs and develops a block diagram from the gathered information to check the logical flow or determine the operation of the project. Figure 5 is the block diagram of the primary electrical system of the Multi-featured Food Cart and Figure 6 is the block diagram of the secondary electrical system of the Multi-Featured Food Cart.

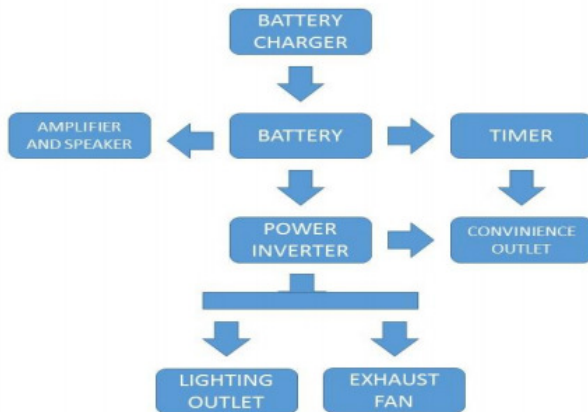

Figure5 Block Diagram of the Primary Electrical System

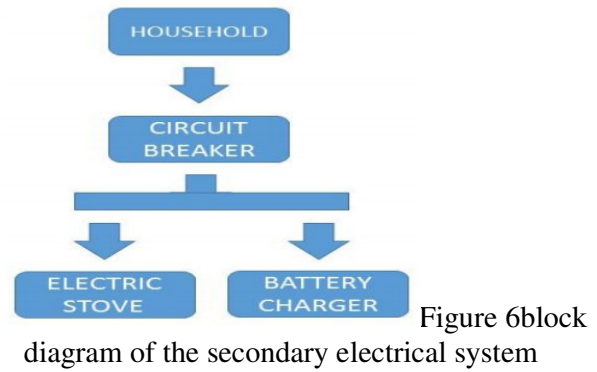

Figure 6block diagram of the secondary electrical system

Circuit Design

Figure 8 below shows the circuit design of the electrical system of the Multi-featured Food Cart; it has two electrical systems, the primary electrical system and secondary electrical system.

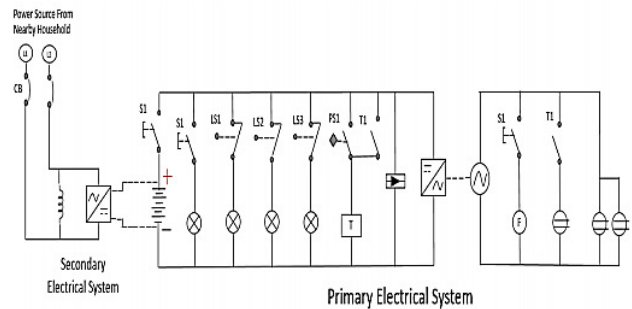

Figure 8Circuit Design of the Electrical System

The primary electrical system is composed of a 12V DC battery as the power source which directly supplies four lighting outlets, the timer module for the coin operated convenience outlet, the audio amplifier and the power inverter. The output of the power inverter also belongs in the primary electrical system in which as shown in the figure is the exhaust fan, two convenience outlets and one coin operated convenience outlet.

The secondary electrical system is composed of an electric stove and a battery charger. As shown in the figure, the secondary electrical system is supplied by a 220V AC from the power source of any nearby household. It is also illustrated below that the battery charger is connected to the battery.

Evaluation Instruments

The researchers utilize a survey questionnaire to evaluate the acceptability of the Multi-featured Food Cart. The project was rated by the respondents

in terms of aesthetics, functionality, reliability, and safety. The developed device was evaluated using Likert's scale. The project was rated by the respondents as shown in the rating scale below.

- 1.4 - Below -Not Acceptable
- 1.5 - 2.4 - Acceptable
- 2.5 - 3.4 - Slightly Acceptable
- 3.5 - 4.4 - Moderately Acceptable
- 4.5 - Above - Highly Acceptable



Figure 10 Front View of the Multi-featured Food Cart

IV. RESULTS AND FINDINGS

Completed Design

The study did a thorough evaluation of the Multi Featured Food Cart. The result was the basis in the design of the system. The design has been implemented, and tested for its workability, functionality, and has been based on the needs of the users when it comes in food cart.

In Figure 9 it shows the planned design of the Multi-featured Food Cart (left) compared to the actual design of the Multi-featured Food Cart (right) when its roof is being lowered and the roof is being folded.



Figure 9 Completed Multi Featured Food Cart

Figure 10 shows the Front view of the Multi-featured Food Cart where you see the foldable and extendable roof, caster wheels and the weather proof lighting fixture.

Figure 11 below shows the graph of the overall rating of respondents' evaluation on the acceptability of the Multi-feature Food Cart. The acceptability of the Multi-featured Food Cart is evaluated in four different categories; in terms of aesthetic, functionality, reliability and safety.

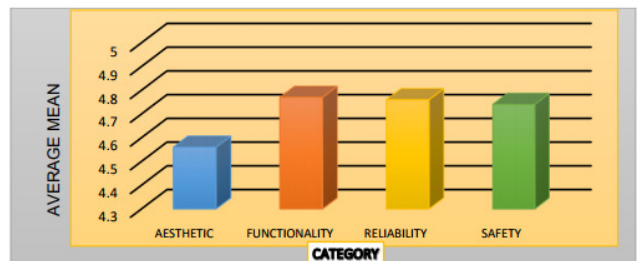

Figure 11 Graph of the Overall Rating of Respondents' Evaluation on the Acceptability of the Multi-Feature Food Cart.

As shown in the graph above the highest rating is the carts functionality which has a numerical value of 4.77 followed by its reliability which is 4.76 and then its safety which is 4.74 and lastly the carts aesthetic which is 4.56.

V. CONCLUSIONS

The Multi featured Food Cart was able to operate according to its function that meet the needs of the end users to have food cart that has more functions such as it has its own electrical system (lighting

system, convenience outlets, soundsystem, and ventilations) and an improved structure (foldable roof, collapsible tables, space efficient and beautiful design) which makes it more attractive than the ordinary food carts.

The parameters used by the researchers in evaluating the acceptability of the Multi-featured Food Cart are aesthetic pertaining to the overall design of the cart, functionality in terms of its usefulness, reliability and safety. Based on the result of the survey, it shows that the respondents found out that the project prototype came out with good aesthetics, with the parameter average mean of 4.56 which has proved that the design is good, nice to look at, and each of its components are properly installed. With respects to the functionality of the system, the respondents found that the components of the system are working well with an average mean of 4.77. With the Multi-featured Food Cart's reliability, the average mean was 4.76 which imply that the oven operates according to the desired control circuit and was highly acceptable in terms of its reliability. In terms of the safety of the system, the respondents found out that it is safe to use, all the components are properly installed, and at the same time it is also userfriendly with the average mean of 4.74.

Recommendations

Based on the testing and evaluation conducted on the project, the researchers came up to these following recommendations:

1. Encourage further study for more development and application of the Multi-featured Food Cart.
2. To find a convenient and lesser weight structure of the foldable roof and a easy process of extension, retraction and locking system of the extendable metal tube.
3. To find another type of material this is lesser in weight for the body of the Multi-featured Food Cart. Also, replace the table top, and roofing plane sheets with stainless steel plane sheets to increase the durability.

4. To add more features and functions such as the following:

- 4.1 Utilize the roof by installing solar panel as another power source of the Multi-featured Food Cart
- 4.2 Replacing the Styrofoam cooler box with a portable electric cooler for a more efficient way of storing food.
- 4.3 Installing a portable DVD player with TV as an addition to the appeal of the Multi-featured Food Cart.
- 4.4 Add more time operated convenience outlets for the customer.

REFERENCES

1. Subrahmanyam Divya. "Food cart: A boon to parent restaurants?". *Yale Daily News*. March 31, 2008. Online. January 7, 2017.
2. Arboleda, Ginger. "The Food Cart Business in the Philippines". *Manila Reviews*. July 5, 2010. Online. January 5, 2017.
3. S.O. Akinbode, A.O. Dipeolu, P.A. Okuneye. "Willingness to pay for street food safety in Ogun State, Nigeria" *J. Agric. Food Inf.*, 12 (2011), pp. 154-166
4. N.D. Canini, J.J.O. Bala, E.N. Maraginos, B.C.B. Mediana. "Evaluation of street food vending in Ozamiz city". *J. Multidiscip. Stud.*, 1 (2013), pp. 104-124
5. "The Melting Pot: How Ethnic Foods Survive Through Early Mobility Part 2". *Herald Standard*. April 30, 2015. Online January 5, 2017.
6. "New food cart concept". *Filtrepreneur*. October 22, 2013. Online: January 8, 2017.
7. "Hot Dog Cart History - Everything Hot Dog". *All American Hot Dog*. Online. January 10, 2017.
8. Mclaughlin Katy. "Food Truck Nation". *The Wall Street Journal*. June 5, 2009. Online. January 7, 2017.
9. Wilk, R. R. 2006. *Fast food/slow Food: The Cultural Economy of the Global Food System*. Vol. 24. Altamira P
10. B.A. Alimi, A.T. Oyeyinka, L.O. Olohunbebe. *Socio-economic characteristics and willingness of consumers to pay*

for the safety of fura de numu in Ilorin, Nigeria. *Qual. Assur. Saf. Crops Foods*, 8 (2016), pp. 81–86

11. E.O. Ekanem. *The street food trade in Africa: safety and socioenvironmental issues. Food Control*, 9 (1998), pp. 211–215

12. M. Choudhury, L. Mahanta, J. Goswami, M. Mazumder, B. Pegoo. *Socioeconomic profile and food safety knowledge and practice of street food vendors in the city of Guwahati, Assam, India. Food Control*, 22 (2011), pp. 196–203

13. S.O. Akinbode, A.O. Dipeolu, P.A. Okuneye. "Willingness to pay for street food safety in Ogun State, Nigeria" *J. Agric. Food Inf.*, 12 (2011), pp. 154–166

14. Veneracion Connie. "Abundant Fishball Vendor". *Casa Veneracion*. November 17, 2012. Online. January 8, 2017.

15. Goco Nicco. "Manila's Meals on Wheels: A Food Cart Revolution". *Pepper.* February 15, 2013. Online. January 11, 2017.