

Design and Analysis of Stress Induced in Spur Gear Tool Profile Using CATIA and ANSYS

Puspraj Singh¹, Gaurav Verma², Dr. L.P. Singh³

¹M.Tech., Sam Higginbottom University of Agriculture, Technology and Sciences, Allahabad

²M.Tech., Sam Higginbottom University of Agriculture, Technology and Sciences, Allahabad

³Assistant Professor, Sam Higginbottom University of Agriculture, Technology and Sciences, Allahabad

Abstract:

Spur gear is a gear which is used to transmit power from one shaft to another shaft. At the time of power transmission several types of stresses presented on gear while designing. The bending stress is considered as the main cause of failure during the transmission of power. In the present study bending stress can be calculated by using AGMA and ANSYS. CATIA V5R19 is used for designing of gear. Then file is saved in IGES format and imported in ANSYS 15.0 where it analyzed. The major purpose of this study has to investigate the stress induced in a spur gear tooth parameter. At the end AGMA and ANSYS results has been compared with each other.

Keywords — Spur gear, Design, Modeling, AGMA, CATIA, ANSYS and Analysis.

I. INTRODUCTION

Over 1957, Walker procedure gear might have been handling its introductory pier upheld inside spur gear drives. In the late 1970's, the tooth rot structure might have been changed with full profundity and the weight point might have been expanded should 25 degrees starting with the prior 20 degrees weight point stub tooth rot configuration. The weight point progress brought expanded bowing quality of the teeth concerning illustration distinguished Toward AGMA. In the mid 1980's, WPE included a throws steel interior spur gear to its item accordance. Today, the design evolution continues with further changes in design for better quality of gear for maximum load capacity and minimum loss due to failure.

Spur gears are the most common type of gears. They are used to transmit rotary motion between parallel shafts. The knowledge of gear behavior in mesh such as stress distribution, work condition and distortion is critical to monitoring and controlling the gear transmission system. Gears generally fail when the working stress exceeds the maximum permissible stress.

Advances in engineering technology in recent years have brought demands for gear tooth, which can operate at every increasing load capacities and speeds. Therefore, it is essential to determine the maximum stress that a gear tooth is subjected under specific loading. Analysis of gears is carried out so that these can prevented from failure.

The spur gears are mainly used because they have high power transmission efficiency. They are compact and easy to install. They offer constant velocity ratio. Unlike belt drives, spur gear drives have no slip. Spur gears are highly reliable. They can be used to transmit large amount of power (of the order of 50,000 kW).

Spur gears are having wide range of applications. They are using in metal cutting machines, power plants, Mechanical clocks and watches, Fuel pumps, Washing machines, Gear motors and gear pumps, Material handling equipment's, Automobile gearboxes, Steel mills, Rolling mills. Etc.

II. LITERATURE REVIEW

J.L. Moya, *et al.* (2007) they have performed a theoretical analysis of a

procedure to determine the Lewis Factor and also performed the contact analysis of spur gears to find the stress distribution between gear teeth.

V. Siva Prasad *et al.* (2012) analyzed design of spur gear and proposed a gear for sugarcane juice machine. They created a model in PRO-E and analyzed in ANSYS10.0. From the analysis they found the Nylon gear is suitable for the application of sugarcane juice machine under limited load condition compared with cast iron spur gear.

N.Lenin Rakesh *et al.* (2013) investigated a spur gear is modeled using a modeling software Pro-E and using software ANSYS. The theoretical stresses of both bending and contact stress is found manually and then analyzed in ANSYS software. The readings are shown in the tabular column. It is found that comparing with manual results, results are approximate or closer to it.

Nitin Kapoor *et al.* (2014) analyzed parametric model of differential Gearbox by using CATIA-V5. Glass filled polyamide composite and metallic materials (Aluminum alloy, Alloy Steel and Cast Iron) are also being performed and analyses using ANSYS for equivalent (Von-Misses) stress, displacement and maximum shear elastic strain for different revolutions under static conditions. A comparison gives Glass Filled Polyamide composite material is selected as a best material for Differential gear box.

L. kavin Rajkumar *et al.* (2014) analyzed the stress in gear tooth, to reduce the stress in the gear tooth. An ANSYS analysis of spur gear is used. A Finite Element model with aero-fin shaped hole along the stress flow direction gives better results to reduce the stress in the spur gear contact tooth. The study gives the better result

when an aero-fin hole is introduced and reduces the stress in the gear teeth.

Maheeb Vohra *et al.* (2014) explained the Metallic material Cast iron and Non Metallic material Nylon are for spur gear. The stress analysis of the lathe machine headstock gear box is analyzed by finite element analysis (FEA) and ANSYS. They got the theoretical results are about to same with minor differences.

Pradeep Kumar Singh *et al.* (2014) compared analysis with ANSYS and AGMA. The Hertz theory and Lewis formula are used for theoretical calculation of contact stress and bending stress of spur gear. They observed that theoretically results obtained by Lewis formula and Hertz equation are quite similar with little differences.

Sangamesh Herakal *et al.* (2014) investigated the dynamic analysis of natural frequency of spur gear FEA and MATLAB. The results of FEA and MATLAB analysis are compared and they found that the natural frequency is increases with increase in fiber orientation.

III. OBJECTIVES

- To design and make model of Spur Gear using CATIA V5.
- To analyze the designed model using AGMA parameter and ANSYS.
- To compare the results obtained by AGMA and ANSYS.

IV. MATERIALS AND METHODOLOGY:

As we know that for proper designing the selection of material is an important factor. So for proper designing of spur gear we use the material i.e. structural steel.

In the Lewis equation the factors are as given below :

Wt = Tangential Load

σ_b = Equivalent Stress

b = Face width

m = Normal module

T = Applied torque or moment

d = Pitch diameter of gear

y = Lewis Form Factor.

V. MATHEMATICAL MODEL CALCULATIONS:

Model - TATA INDICA

ENGINE – TATA 475 IDI TURBO

TORQUE – 135N-m.

SPEED - 2500 r.p.m.

The AGMA equation for bending stresses is given by

$$Wt = \frac{T}{\left(\frac{d}{2}\right)}N$$

Where $d = N \cdot m$

$$\sigma_b = \frac{Wt}{b \cdot y \cdot pc} \text{ Mpa}$$

Where $pc = \pi m$

All the values are put in above equations

For $m=3.5$, $b= 10$

$$Wt = \frac{T}{\left(\frac{d}{2}\right)}N = 3214.28N$$

$$\sigma_b = \frac{Wt}{b \cdot y \cdot pc} \text{ Mpa} = 88.47 \text{ Mpa}$$

For $m= 4$, $b= 10$

$$Wt = \frac{T}{\left(\frac{d}{2}\right)}N = 2812.5 \text{ N}$$

$$\sigma_b = \frac{Wt}{b \cdot y \cdot pc} \text{ Mpa} = 67.70 \text{ Mpa}$$

For $m= 5$, $b=10$

$$Wt = \frac{T}{\left(\frac{d}{2}\right)}N = 2250 \text{ N}$$

$$\sigma_b = \frac{Wt}{b \cdot y \cdot pc} \text{ Mpa} = 43.22 \text{ Mpa}$$

For $m= 6$, $b= 10$

$$Wt = \frac{T}{\left(\frac{d}{2}\right)}N = 1875 \text{ N}$$

$$\sigma_b = \frac{Wt}{b \cdot y \cdot pc} \text{ Mpa} = 30.10 \text{ Mpa}$$

VI. RESULTS & DISCUSSION:

Module and face width are important geometrical parameters in determining the state of stresses during the designing of gears. Thus, the objective of this work is to conduct a parametric study by varying the module to study their effect on the bending stress of spur gear. In order to determine the stresses variation with the module four different models of spur gear were created by keeping other parameters (i.e. face width, pitch circle diameter, number of teeth, pressure angle, power, speed etc.) constant. Table below shows the results of bending stress with the variation in the face width of the spur gear tooth.

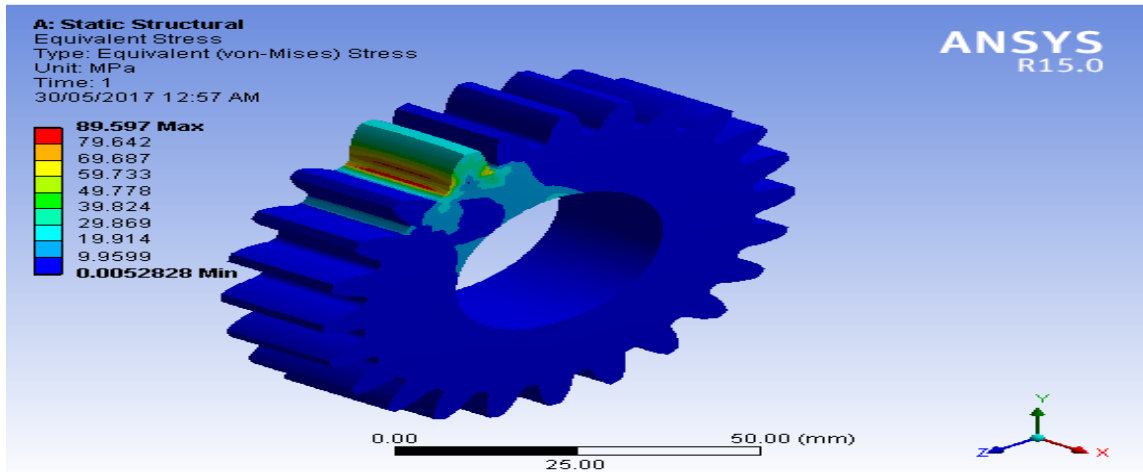

Figure 1. Equivalent stress of module 3.5.

Above figure 1 indicates that the Equivalent (Von- Mises) stress for spur gear [m= 3. 5, b= 10mm] with 24 teeth. When tangential load from clamping 3214.28 N will be connected looking into

a teeth of spur gear, that stress calculated by AGMA is 88. 47 MPa and by ANSYS is 89.597 Mpa. The differences between both results are 1.27%.

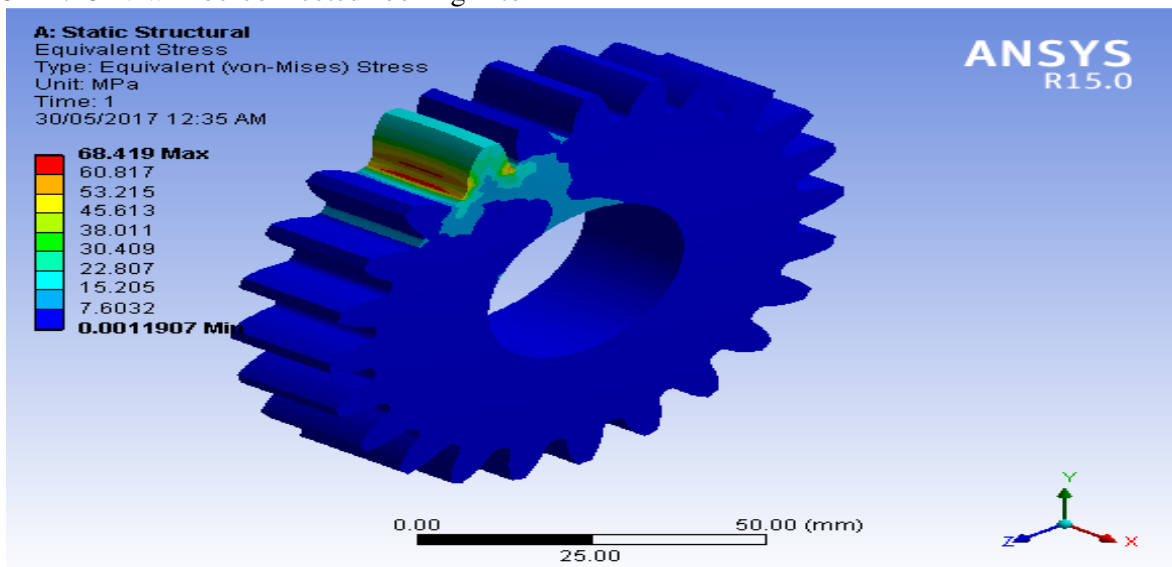

Figure 2. Equivalent stress of module 4

Above figure 2 indicates that the Equivalent (Von- Mises) stress of spur gear for [m= 4, b= 10mm] and having 24 teeth. When tangential load of 2812.5N is

applied on a teeth of spur gear, then obtain bending stress by AGMA standards is 67.70MPa and by ANSYS is 68.419MPa and their difference is 1.68%.

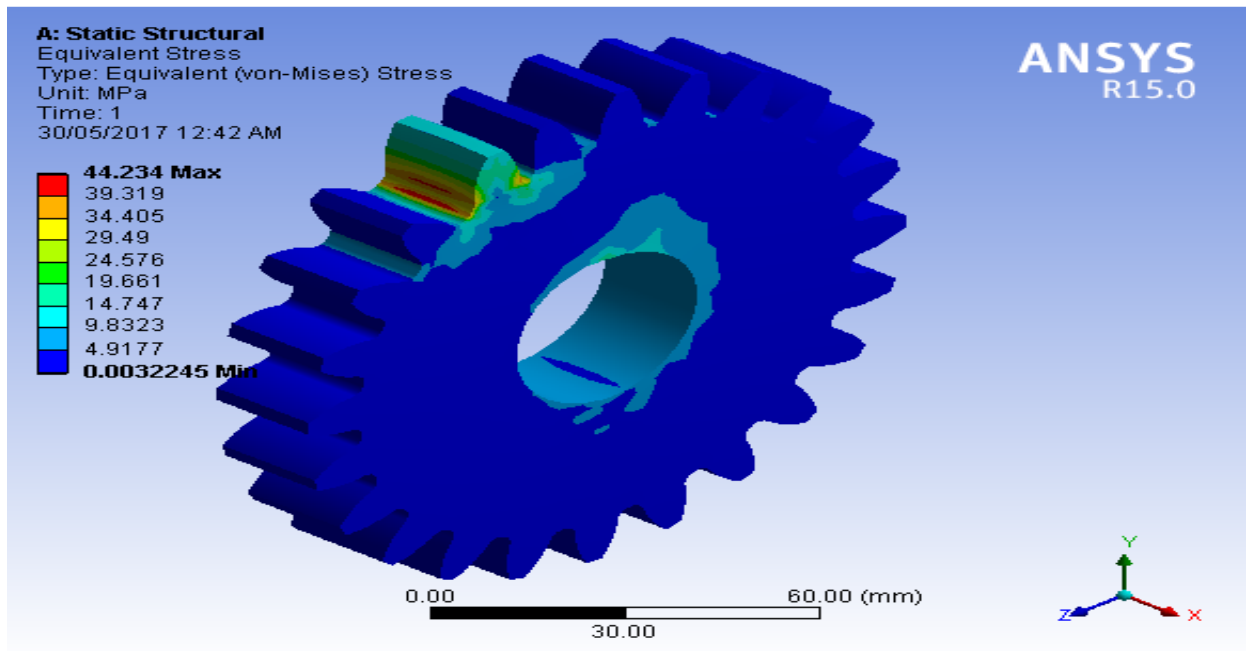

Figure 3. Equivalent stress of module 5

Above figure 3 shows that the Equivalent (Von- Mises) stress of spur gear [m= 5, b= 10mm] and with 24 teeth. When tangential load of 2250 N is applied on a teeth of

spur gear, then observed bending stress by AGMA standards is 43.32 MPa and by ANSYS is 44.234 MPa and their difference is 2.10%.

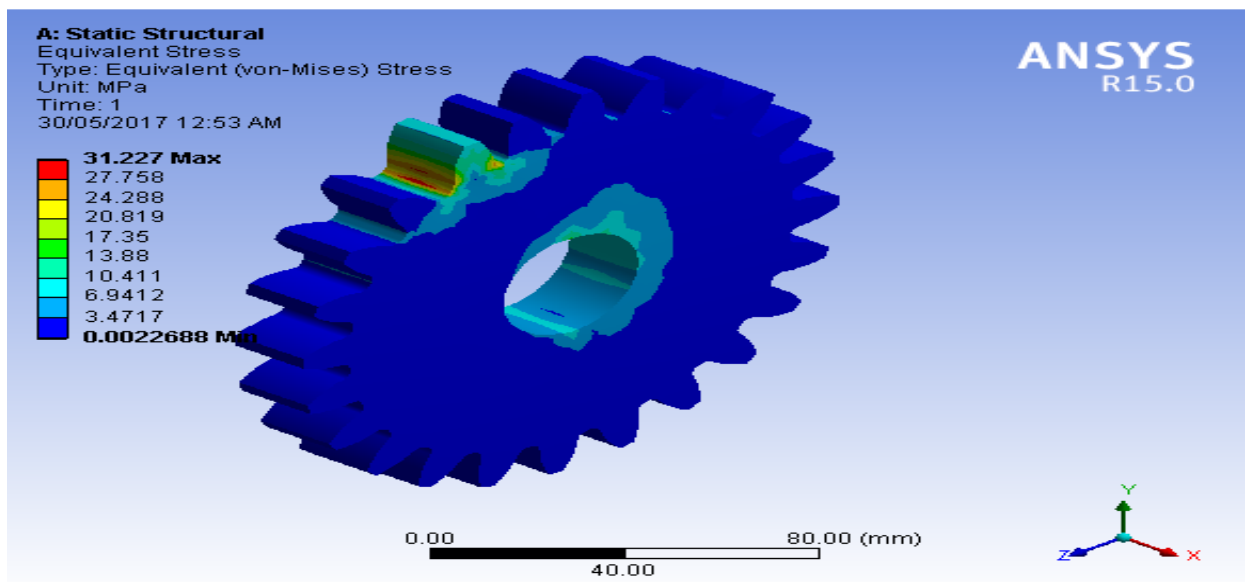

Figure 4. Equivalent stress of module 6

Above figure 4 shows that the Equivalent (Von- Mises) stress of spur gear [m= 6, b= 10mm] and having 24 teeth. When tangential load of 1875 N is applied on a teeth of spur gear, then obtain bending stress by AGMA standards is 30.10 MPa and by ANSYS is 31.227 MPa and with

comparison we found that the difference is 3.74%.

The given table of Bending Stresses [MPa] of AGMA and ANSYS clearly shows that when the values of module are increasing, then there is continuous decrease in the bending stresses of both the AGMA and ANSYS.

TABLE for Bending Stresses [MPa] of AGMA and ANSYS

S.No.	Module [mm]	Face Width [mm]	Bending Stresses [AGMA]	Bending Stresses [ANSYS]	Differences [%]
1	3.5	10	88.47	89.59	1.27
2	4	10	67.70	68.41	1.68
3	5	10	43.32	44.23	2.10
4	6	10	30.10	31.22	3.74

From the analysis, by comparing the results of ANSYS and theoretical results, it can be seen that the results are nearly equal, and the percentage difference is found to be from 1.06 to 3.74%. Hence, we can say that ANSYS workbench is a reliable source for bending stress analysis.

VII. CONCLUSION

The results obtained from ANSYS when compare with the AGMA procedure, it shows that there is a little variation with a higher difference in percentage of 3.74%. From the results we can conclude that ANSYS can also be used for predicting the values of bending stress at any required module and face width which is much easier to use and to solve the complex design problems like gears.

VIII. ACKNOWLEDGEMENT

I would like to express my gratitude and heart full thanks to our mentor Dr. L.P.Singh, Assistant Professor, SHUATS,Allahabad for his variable guidance and constant encouragements at various stages.

IX. REFERENCES

1. J.L. Moya, A.S. Machado —A new approach for polyamide composite gear design, *Wear* 262 (2007) 432-441.
2. V. Siva Prasad, Syed Altaf Hussain, V. Pandurangadu, K. PalaniKumar, " Modeling and Analysis of spur gear for Sugarcane Juice Machine under Static Load Condition by Using FEA", July-Aug 2012, *International Journal of Modern Engineering Research*, Vol- 2/4, pp-2862-2866.
3. N. Lenin Rakesh, V. Palanisamy and Sidharth Das, *SPUR Gear Analysis Using Finite Element Analysis. Middle-East Journal of Scientific Research* 14 (2012): 1763-1765, 2013.
4. Nitin Kapoor, Virender Upneja, Ram and Puneet Katyal, *Design and stress strain analysis of composite difference gear box, IJSETR, Volume 3, Issue 7, July 2014.*
5. L. Kavin Rajkumar and A. Dyson Bruno, *Design and analysis of shear stress reduction in aero-fin holed spur gears. August, 2014 IJERST Vol. 3, No. 3*
6. Maheub Vohra, Prof. Kevin Vyas, "Comparative Finite Element Analysis of Metallic and non-Metallic spur gear", May-June 2014, *IOSR Journal of Mechanical and Civil Engineering, Vol-11/3, pp- 136-145.*

7. Sangamesh herakal, Shravan Kumar B.kerur, *Dynamic Analysis of Composite Spur Gear*. IRF International Conference, 18 May-2014.

8. Sandip c. patel, Dr. S.G Sarganachri, *Review of composite asymmetric spur gear*. IJER, 01 Feb 2015.

9. M. Patil, S.Herakal, S. B. Kerur, *"Dynamic Analysis of Composite spur gear"*, May- 2014, *Proceedings of 3rd IRF International Conference*.

10. *Textbook of Machine Design* by R.S.Khurmi, J.K. Gupta.