



## Considerations Regarding the Characterization and Design of Vertical Earth Grounding

Virgil Maier, Sorin G. Pavel, Horia G. Beleiu, Constantin S. Pică

*In the paper, five global and synthetic sizes are proposed for the earth grounding, predestined to represent distinguishing criteria and to justify the chosen solution: the footprint area, the dispersion surface, the metal part mass and the earth grounding volume have technical character, while the investment cost has an economic nature. Resuming the sizing relationships of earth grounding gives the opportunity to develop a new nomogram for calculating the dissipation resistance of a single vertical earth grounding as well as highlighting the quality and quantity of its specific dependencies. Processed forms are presented in the paper as well for the use coefficients of the multiple earth grounding, defining the determination of the electrode number which minimizes at least one of the proposed global sizes as the main target of the study.*

**Keywords:** *vertical earth grounding; earth grounding dispersion resistance, earth grounding general characteristics; nomographic calculation; artificial earth grounding.*

### 1. Introduction

The design of earth grounding, at nominal dispersion resistances, is relatively laborious and there are no substantiated criteria to provide justification to the chosen solution. The rated dispersion resistance of the earth grounding (EGR) belongs to the set  $R_{p,r} \in \{1, 4, 5, 10\} \Omega$  in accordance with their destination, as follows:

- 1  $\Omega$  for the dispersion resistance of the EGR destined to the protection against lightning surges;
- 4  $\Omega$  for EGR to protect personnel against electric shocks caused by indirect

touches;

- 5  $\Omega$ , for special pillars, taller than 40 m, at 110 kV overhead lines;
- 10  $\Omega$  for EGR of a power supply point, in the cases of TN and TT grounding connection schemes, for overhead line poles and for lightning protection.

Making EGR dispersion resistances at values smaller than  $R_{pn}$  is uneconomic and at higher values it is not allowed because it would not satisfy adequately the purpose for which it was provided, so that the tendency of designers and contractors must be to realize as close as possible to the limit the condition:

$$R_p \leq R_{pn}. \quad (1)$$

Further on, only the artificial EGR is considered to be dimensioned, so that there is no a natural one and the EGR is made of vertical electrodes, connected between them through steel plate, horizontally posted and welded on the upper ends of the vertical electrodes.

The dispersion resistance  $R_p$  of the multiple EGR, carried out by the parallel connection of same  $n_e$  electrodes is determined by the general relationship [1]:

$$R_p = \frac{r_p}{u_p \cdot n_e}, \Omega, \quad (2)$$

where  $r_p$  is the dispersion resistance of a single EGR, with one electrode;

$u_p$  - the use coefficient of the multiple EG.

As in (2), the rated value can be attributed to the size of  $R_{pn}$  as  $R_p = R_{pn}$ , this making it a constant, the mentioned relationship can be used to determine the electrodes number  $n_e$ , while all the EGR characteristic sizes would be set:

$$n_e = \frac{1}{R_{pn}} \cdot \frac{r_p}{u_p}. \quad (3)$$

The above relationship materializes the main aim of this work, which seeks the reconsideration of the EGR design algorithm, defining for them additional characteristic values, which can be criteria in choosing the constructive main sizes, the settlement of the EGR design on new and simplified bases. To identify the criteria for achieving EGR optimal sizing represents another objective of this paper.

## 2. EGR characteristic sizes

### 2.1. Dimensional sizes

A multiple EGR, with vertical stakes is considered, as shown in Fig. 1, where only two adjacent electrodes (2) are represented, indicating the stakes typical dimensions and their location, with the following meanings:

$d$  - pipe type electrodes diameter;

$l$  - the electrodes length;

$g$  - the pipe thickness;

$q$  - the burial depth of the electrode upper part;  
 $t$  - the distance from the ground level to the vertical electrode mid-length, existing the connecting relationship:  

$$t = q + 0,5 \cdot \ell, \text{ m}; \quad (4)$$
 $a$  - the distance between two electrodes in the horizontal plane;  
 $h$  - length of the electrode sharp part.

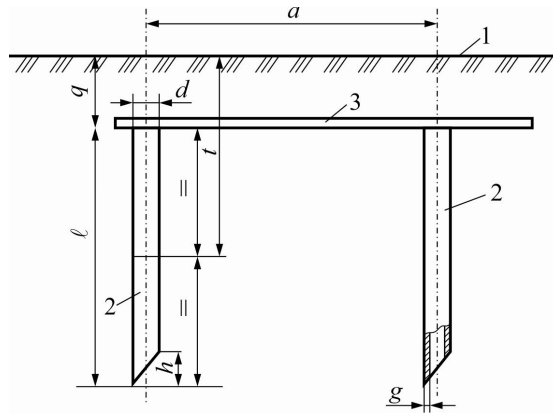

**Figure 1.** Multiple EGR fragment with vertical electrodes and main sizes.

The connections between the vertical electrodes (2) is carried out by galvanized strip-like steel conductors (3, Fig. 1), or by other conductors types, corresponding to the soil nature and to the EGR type.

## 2.2. Simple EGR dispersion resistance

The dispersion resistance  $r_{pv}$  of a single vertical electrode, with the diameter  $d$  much smaller than the length  $\ell$  ( $d \ll \ell$ ) is given [1,3,7] depending on the electrode sizes and on the burial depth  $q$  of the electrode upper part (Fig. 1), by the relation:

$$r_{pv} = 0,366 \frac{\rho}{\ell} \left( \lg \frac{2\ell}{d} + \frac{1}{2} \lg \frac{4t + \ell}{4t - \ell} \right), \quad (5)$$

where  $t$  is the variable given by the equation (4). By interpreting this variable, the following relationship is obtained:

$$r_{pv} = 0,366 \rho \frac{1}{\ell} \lg \frac{2}{d/\ell} + 0,5 \lg 1 + \frac{1}{2(d/\ell) + 0,5}, \quad (6)$$

where the dimensionless variables  $(d/\ell)$  and  $(q/\ell)$  were highlighted, which increases the generality degree of the relationship (6) and prepares it for a nomographic representation, shown in the Figure 2. In the first quadrant, the dimen-

sionless size  $(d/\ell)$  was elected as an independent variable and the size  $(q/\ell)$  was chosen as parameter; the domain  $(d/\ell) \in [1 \div 7] \cdot 10^{-2}$  was considered for the abscissa and the parameter values are  $(q/\ell) \in \{0,1; 0,5; 0,9\}$ .

For the electrode length  $\ell$  the following set of values is considered:  $\ell \in \{1; 1,5; 2; 3; 4; 6\}$  m, from technical and economic considerations, in order to have no pipe material losses when manufacturing the normal pipe lengths of 4 or 6 m.

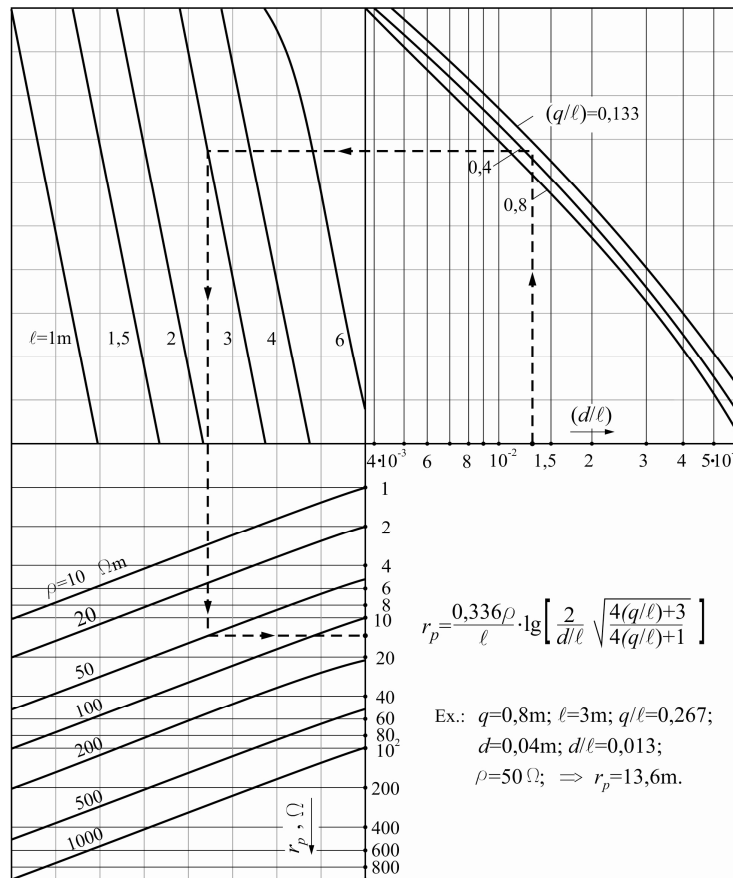

**Figure 2.** Nomogram for determining the dispersion resistance of the simple, vertical EGR.

For the electrode length  $\ell$  the following set of values is considered:  $\ell \in \{1; 1,5; 2; 3; 4; 6\}$  m, from technical and economic considerations, in order to have no pipe material losses when manufacturing the normal pipe lengths of 4 or 6 m.

Both from the relationship (6) and the nomogram (Fig. 2), it can be noticed that the dispersion resistance value  $r_{pv}$  varies inversely proportional to the vertical electrode length  $l$ . Also,  $r_{pv}(d/l)$  and  $r_{pv}(q/l)$  dependencies have inversely proportional character type; it may be mentioned that, while a variation on the whole considered domain of the variable  $(d/l)$  leads to a variation of about 40% of the  $r_{pv}$  resistance value, relative to the parameter  $(q/l)$  the variation is less wide, fitting up to about 1% in the same conditions.

### 2.3. Proposed overall characteristic sizes

The dependencies evidenced by (6) and reproduced both qualitatively and quantitatively by the above nomogram (Fig. 2) show, through them monotony, that optimum criteria cannot be applied in sizing the dispersion resistance  $r_{pv}$  of a simple, vertical EGR. Therefore, it is necessary to defined overall characteristic values, as synthetic and expressive, which allow the definition of optimum criteria.

Consequently, the following overall, characteristic sizes for EGR are proposed:

- EGR footprint, characterized by its area;
- the area of the EGR dispersion surface;
- the volume or the mass of the conductive material, used for the EGR physical realization;
- EGR total volume;
- the investment costs of EGR.

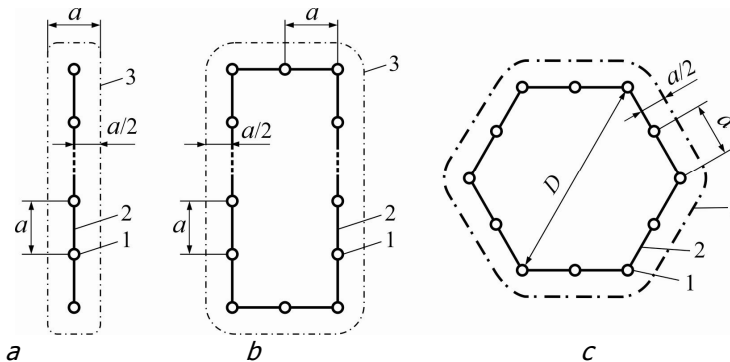

**Figure 3.** Multiple EGR footprint, with electrodes placed: *a* - in a straight line; *b* - on the perimeter of a rectangle; *c* - on the outline of a regular polygon; 1 - electrode; 2 - connecting wire; 3 - footprint contour.

**a.** The **EGR footprint** means its image seen from above, so in the horizontal plane, highlighting the position and the number of metal vertical stakes, the distance between them and the geometrical figure made by all stakes. The three basic ways for the multiple EGR configuration, in horizontal plane, are as follows:

- the electrodes are arranged in a straight line (Fig. 3, *a*);
- the electrodes define the perimeter of a rectangle (Fig. 3, *b*);
- the electrodes are placed on the perimeter of a regular polygon (Fig. 3, *c*).

In order to set the footprint equivalent area on the ground, bounded by the

contour 3, plotted with thin dash-dot line (Fig. 3), it is proposed that for the marginal electrodes a distance of  $(a/2)$  to be considered from the electrode axel up to the footprint contour, as materialized on the graphical representation.

In the EGR with electrodes placed in a straight line case, the footprint area is:

$$A_{Pl} = n_e a^2, \text{ m}^2, \quad (7)$$

where  $n_e$  is the electrodes number of a multiple EGR.

The footprint area of the multiple EGR with electrodes placed on a rectangle outline (Fig. 3, *b*) may be similarly determined, so the next relation is proposed:

$$A_{Pd} = \frac{\gamma_d a (n_e - 4)^2}{4(1 + \gamma_d)}, \text{ m}^2, \quad (8)$$

where  $\gamma_d$  represents the aspect ratio of the rectangle, given by the ratio:

$$\gamma_d = \frac{n_{e2}}{n_{e1}} \quad (9)$$

between the electrodes number  $n_{e2}$  from the width and the electrodes number  $n_{e1}$  from the length of the rectangle outlined by the electrodes assembly.

The EGR footprint area when the electrodes are located on a regular polygon contour will be determined by the designer versus the chosen regular polygon.

**b. The EGR dispersion surface area** shall be considered as the total EGR area in contact with the ground, composed by the sum of the electrodes exterior areas and the external area of the link conductor, between the electrodes, according to the relationship

$$A_{DP} = \pi d \ell n_e + (n_e - 1) \rho_b, \quad (10)$$

where the EGR characteristic sizes explained above (Fig. 1) may be found and  $\rho_b$  is the perimeter of the metallic conductor that connects the electrodes.

**c. The mass or the volume of the EGR metal** may constitute another overall size, characteristic for EGR, because it combines sizes like diameter, length, thickness and number of electrodes, with the connection conductor dimensions.

Considering that the EGR overall metal mass  $M_p$ , comprising metal stakes mass as well as the connection wire mass represents, from technical point of view, a more suitable size than the volume, its calculation relationship is determined for multiple EGR, with vertical electrodes, in the form:

$$M_p = \rho_m [\pi g d (g) n_e + (n_e - 1) S_b], \quad (11)$$

where  $\rho_m$  is the density of the metal constituting the electrodes and the connection wire between them;  $g$  - the pipe thickness, in m;  $S_b$  - the connecting wire cross section, in  $\text{m}^2$  and the other quantities are as defined above.

#### **d. The EGR total volume**

The fourth criterion proposed for the EGR whole characterization refers to the total volume  $V_p$ , occupied by EGR, given by the relationship:

$$V_p = A_p (q + \ell), \quad (12)$$

where  $A_p$  is the area of the EGR footprint, in  $m^2$ .

The EGR total volume combines the characteristic sizes from the horizontal plane, such as the distance  $a$  between electrodes, the electrodes number  $n_e$  and the location system with the sizes from the vertical plane, represented by the electrode length  $\ell$  and the burial depth  $q$ .

#### e. Investments costs

The total cost with the EGR comprises the costs of materials for its realization, the labor expenses, as well as, when applicable, the costs of acquiring the land occupied by the EGR. Material consumptions include, besides metal parts such as electrodes and connecting wires, some fillers material such as bentonite and a series of small materials, according to the norms. Small materials mean those auxiliary materials which intervened in the works, in small amounts as follows: welding electrodes, screws, nuts and bolts, clamps, adhesives, paint, bitumen etc.

The complete relation for the investment expenditures calculation, which also performs the differentiation of the various variants of the EGR, is the following:

$$I_p = (C_{em} + C_b) \cdot (M_e + M_q + M_a) \cdot C_p, \text{ m.u.}, \quad (13)$$

where  $C_{em}$  represents the cost of the electrodes and of the small materials;

$C_b$  - the cost of connecting wire (ex. iron strip), between the electrodes;

$M_e$  - labor costs for manufacturing, installation (i.e. minting) and interconnect (ex. laying and welding) of electrodes;

$M_q$  - labor charges for stripping electrodes route, for their placement at an established depth  $q$ ;

$M_a$  - coverage labor charges of the realized EGR;

$C_p$  - cost of the land occupied by the EGR;

m.u. - the currency (monetary units, ex. RON, Euro), expressing costs.

Among these costs, the following can be expressed in the basis of the rules of tender, in relation to some characteristic parameters of the EGR:

- the  $C_{em}$  cost of the electrodes and of the small materials,

$$C_{em} = c_e (1 + m_{\%}) n_e, \text{ m.u.} \quad (14)$$

where  $c_e$  is the cost per length unit of the blank electrode, in m.u./m;

$m_{\%}$  - the percentage cost of the small materials, relative to the cost of the electrodes, in %, according to the rules of the tender;

- the  $C_b$  cost of the electrodes connecting wire,

$$C_b = c_b a n_e, \text{ m.u.} \quad (15)$$

where  $c_b$  represents the cost per length unit of the connecting wire, in m.u./m;

- labor cost  $M_e$  for electrodes manufacturing, installation and interconnection,

$$M_e = n_e \ell \sum_j c_{hj} h_j, \text{ m.u.}, \quad (16)$$

where  $h_j$  is the number of hours allocated for the mentioned operations, for the corresponding jobs  $j$ , indicated in the rules of the tender, in h/m (or h/piece when the piece has the established length);

$c_{hj}$  - the value of the working hour, for each of the corresponding jobs  $j$ , in m.u./h;

-  $C_p$  cost of the land occupied by the EGR,

$$C_p = c_p A_p, \text{ m.u.}, \quad (17)$$

where  $c_p$  represents the equivalent cost of the surface unit for the parcel on which EGR is carried out.

### 3. Use coefficients of multiple EGR

Sizes as the simple EGR dispersion resistance  $r_{pr}$  the electrodes number  $n_e$  and the use coefficient  $u_p$  of the multiple EGR appear in relation (2), for calculating the dispersion resistance  $R_p$  of a multiple EGR.

Relations for the calculation of the use coefficients for multiple EGR are given in the normative documents [1, 2, 9], as well as in the manuals of the EGR design [3÷8]. They are concentrated in Table 1, in forms that are less processed, for the three types of electrodes locations: in a straight line, on the perimeter of a rectangle or on the outline of a regular polygon.

**Table 1.** Use coefficients relationships for multiple EGR [11]

Placement of identical electrodes, connected in parallel	Computing relationship	Relation number
Straight line	$u_l = \frac{3 \cdot 2,5\beta}{3 + 2\beta \cdot 7,75\beta^2}$	(18)
On the perimeter of a rectangle	$u_d = 1 + \frac{\rho n_e f k_e}{2\pi p r_p}^{(1)}$	(19)
Regular polygon outline	$u_p = 1 + \frac{\rho n_e f k_e}{2\pi D r_p}^{(1)}$	(20)

The following notations, additional to those defined previously, are used in Table 1:

$\beta$  - a variable defined by the relationship:

$$\beta = \frac{\rho}{2\pi a r_p}; \quad (21)$$

$\rho$  - the rectangle perimeter representing the EGR footprint, in m;



$f(n_e)$  - the function which introduces the dependence of the use coefficient of the electrodes number  $n_{er}$  with values in accordance with Table 2;  
 $D$  - the larger diagonal of the polygon or circumscribed circle diameter, in m.

**Table 2.** Function values  $f(n_e)$  versus the electrodes number  $n_e$

$n_e$	2	3	4	5	6	7	8	9	10
$f(n_e)$	0,5	0,77	0,96	1,1	1,22	1,32	1,41	1,48	1,55
$n_e$	15	20	30	40	50	60	70	80	100
$f(n_e)$	1,81	1,98	2,24	2,11	2,56	2,68	2,78	2,86	3,00

Examining the relationships for the use coefficients calculation (Tab. 1) it can be observed that only for multiple EGR, with electrodes placed in a straight line the use coefficient does not depend on the number of electrodes  $n_{er}$  but of a dimensionless variable  $\beta$ , which no longer involves the soil resistivity value  $\rho$  and which depends only on the dimensional relative variable, such as  $(a/\ell)$ ,  $(d/\ell)$  and  $(q/\ell)$ . We can write therefore, for the variable  $\beta$ , the relationship:

$$\beta = \beta \frac{a}{\ell}, \frac{d}{\ell}, \frac{q}{\ell} . \quad (22)$$

Regarding the other two versions, with electrodes placed on polygons outlines, be it rectangle (19), respectively regular polygon (20), we find that the use coefficient values depend on the electrode number  $n_e$  both explicitly and implicitly, through the function  $f(n_e)$ . In addition, the electrodes number appears once more, distinctly, in the denominator of (2) as the multiplying factor of the use coefficient.

#### 4. Conclusions

In accordance with the actual norms of personnel and buildings security, the EGR rated dispersion resistance should be one of the following set values  $R_{pn} \in \{1, 4, 5, 10\} \Omega$ . Its implementation at lower levels than  $R_{pn}$  is uneconomic, and at higher values – not allowed, because it would not satisfy adequately the purpose for which it was provided.

Given that the electrode main dimensional sizes and their location can be established on the practical or theoretical basis, the design main objective remains the determination of the electrodes number  $n_{er}$  in order to provide an acceptable value for the EGR dispersion resistance.

The dispersion resistance  $r_{pv}$  of the simple vertical EGR varies inversely proportional (rel. 6 and Fig. 2) with both the electrodes length  $\ell$ , and with the relative sizes  $(d/\ell)$  and  $(q/\ell)$ , the last of these ones having a much lower influence. The electrode length influence is most pronounced so that by doubling the length of the electrode resistance value dispersion of EG is reduced by about 40%. The in-

fluence of the electrode length  $l$  is the most pronounced, so that by doubling the electrode length, the EGR dispersion resistance is reduced by about 40%.

The EGR overall characteristic sizes proposed in this paper allow not only a synthetic appreciation of the possible solutions, but can represent a basis for defining optimum criteria, expressing the requirements of some of the involved partners, who can be a beneficiary, contractor or investor. While the footprint area, dispersion surface area, the total weight and volume of conductive material constitute the characteristic values of a technical nature, the EGR investment costs presents an economic character. The full form of writing the relationship for calculating the investment costs highlights the flexibility of this indicator, able to express stakeholders in the investment options.

The analytical expressions of the use coefficients, as well as the contradictory variations of some of the EGR characteristic sizes to achieve an imposed dispersion resistance, lead to the conclusion that designers should look for optimal solutions, on the possible variants multitude.

## References

- [1] \*\*\*\*\* *Normativ pentru proiectarea, executarea și exploatarea instalațiilor electrice aferente clădirilor, I7-2011, vol. 1 și 2.* București: MATRIX ROM, 2011.
- [2] \*\*\*\*\* *Îndreptar de proiectare și execuție a instalațiilor de legare la pământ,* Indicativ 1 RE-IP 30/2004.
- [3] Comșa D., Darie S., Maier, V., Chindriș M., *Proiectarea instalațiilor electrice industriale,* Ediția a doua, București, Editura Didactică și Pedagogică, 1983.
- [4] Lucache D.D., *Instalații electrice de joasă tensiune, Baze teoretice și elemente de proiectare.* Iași, Editura PIM, 2009.
- [5] Mira, N. ș.a. *Manualul de instalații, Instalații electrice și de automatizare.* București: Editura Artecno, 2002.
- [6] Mircea I., *Instalații și echipamente electrice, Ghid teoretic și practic.* București, Editura Didactică și Pedagogică, 2002.
- [7] Sufrim M., Goia M.L., Petran M., *Instalații de legare la pământ.* București, Editura Tehnică, 1987.
- [8] Vasilache G. *Sisteme de protecție împotriva tensiunilor de atingere accidentale.* București, Editura Tehnică, 1980.
- [9] \*\*\*\*\* IE-IP-35/1,2-93, *Îndrumar de proiectare pentru rețelele de medie tensiune cu neutrul tratat prin rezistență. Protecții. Instalații de legare la pământ*
- [10] STAS 7334/78, *Instalații electrice de 1.000 V și peste 1.000 V. Instalații de legare la pământ de protecție.*

- [11] Maier V., Pavel S.G., Beileu H.G., Birou I., Fărcaș V. *Nomograms for sizing the vertical earth grounding*, Proceedings of EPE 2016 Conference, oct. 2016, Iași, Romania.

*Addresses:*

- Prof. Dr. Eng. Virgil Maier, Technical University of Cluj-Napoca, Str. Memorandumului nr. 28, Cluj-Napoca, [virgil.maier@enm.utcluj.ro](mailto:virgil.maier@enm.utcluj.ro)
- Prof. Dr. Eng. Sorin Pavel, Technical University of Cluj-Napoca, Str. Memorandumului nr. 28, Cluj-Napoca, [sorin.pavel@enm.utcluj.ro](mailto:sorin.pavel@enm.utcluj.ro)
- Lecturer Dr. Eng. Horia Beileu, Technical University of Cluj-Napoca, Str. Memorandumului nr. 28, Cluj-Napoca, [horia.beileu@enm.utcluj.ro](mailto:horia.beileu@enm.utcluj.ro)
- Assist. PhD Student. Eng. Constantin Pică, Technical University of Cluj-Napoca, Str. Memorandumului nr. 28, Cluj-Napoca, [sorin.pica@enm.utcluj.ro](mailto:sorin.pica@enm.utcluj.ro)