

THE RESEARCH CONCEPT ON THE WEEDING PROCESS AND THE CONTACT ACTION MACHINES

ФОРМУВАННЯ КОНЦЕПЦІЇ ДОСЛІДЖЕННЯ ПРОЦЕСУ ЗНИЩЕННЯ БУР'ЯНІВ І МАШИНИ КОНТАКТНОГО СПОСОБУ ДІЇ

Ph.D. Eng. Bundza O.Z.¹⁾, Prof. Ph.D. Eng. Nalobina O.O.¹⁾, Assoc.Prof. Ph.D. Eng. Nikitin V.G.¹⁾,
Ph.D. Eng. Tkachuk O.L.²⁾

¹⁾ National University of Water Management and Nature Resources Use, Rivne / Ukraine

²⁾ Lutsk National Technical University, Lutsk / Ukraine

E-mail: olegbundza@gmail.com

Keywords: analysis, weeds, herbicide, contact application, oblique cut

ABSTRACT

The article deals with the kinetics of the weeding process. The authors analyse the key figures to evaluate the effectiveness of machines for contact application; they also present the equation to calculate the final accuracy of the process.

РЕЗЮМЕ

Досліджено кінетику технологічного процесу знищення бур'янів. Розглянуто показники, якими можна оцінити якість роботи машини для контактної нанесення. Виведено вираз для визначення показника чистоти обробки.

INTRODUCTION

Agriculture means provide certain conditions, notably well-timed and effective weeding. The analyses of the production processes in the agricultural enterprises in Ukraine and abroad has shown that this task is accomplished mainly with the help of chemical methods (Lysov A.K., 2012; Melezhyk O.I., 2010; Onyschenko B.V., 2011).

Herbicide spraying means serious undesirable losses caused by wind, evaporation, dropping, working solution drops settling on the soil (Lysov A.K., 2009). Besides, the existing processes aimed to eliminate the weeds have low effectiveness caused by numerous technical reasons and physical and mechanical characteristics of the plants.

The current scientific and practical task is to develop the new equipment of weed infestation decrease that will allow to increase the process effectiveness by reducing unproductive losses and destroy both the stalks and the roots of the weeds (Lemus R., Mowdy M., Davis A., 2013). It is important to develop the weeding technologies (Joseph M. DiTomaso., Drewitz J., 2008; Thomas J. Monaco, 2002) because the existing equipment and machinery have low productivity. The comparative analysis of the present technology has shown the perspectives of contact method of herbicide application on the plants (Moyo C., Harrington K. C., Kemp P. D., Eerens J. P., 2008; Kotov A.A., 2009).

However, the weeding technology with already known contact action equipment can't be used on the areas with big slopes or on the fields and pastures overgrown with weeds having rough stem.

The solution of the current scientific and practical task of more effective weeding process should be based on the system analysis of interaction between the working tools of the machine for contact herbicide application and the stems; it will allow to indicate the process regularities, investigate the reasons of unproductive losses, scientifically explain the way to increase the effectiveness and constructive design of working tools.

MATERIAL AND METHODS

The analysis in literature and statistical reports has proven that the contact method is becoming widely used (Bundza O.Z., Kravets S. V., Nalobina O. O., Nikitin V. G., 2015; Lvov S.M., Putianin Y.P., Shashova M.V., 1990). Its principle is that certain amount of working solution is applied directly on the plant. In comparison with other method it allows: to avoid the losses caused by wind (compared to irrigation); minimize losses caused by dropping and evaporation; eradicate high weeds without damaging low plants; decrease

the loss of working solution; avoid using expensive herbicides of selective effect. This method is successfully used to control high weeds on grazing and agricultural lands. It allows to reduce pollution of agricultural plants with chemicals.

The analysis of the existing machine constructions and their working tools for contact herbicide application has helped conclude the following:

1) the work of this equipment is characterized by the significant losses of working solution that causes:

- environmental pollution;
- great herbicide losses;
- transfer of the chemicals to the agricultural plants.

2) actual equipment is not effective for eradication of the weeds with thick stems when their roots must be destroyed.

In order to eliminate these drawbacks, the authors have designed the weeding machine construction of contact action; the scheme of the working tool is represented in figure 1 (Bundza, O.Z. and Nikitin, V.H., 2010; Bundza O.Z., Kravets S. V., Nalobina O. O., 2015). The machine for contact weeding in combined method consists of three working tools: cutting device, collector of the cut plants and unit for the contact herbicide application.

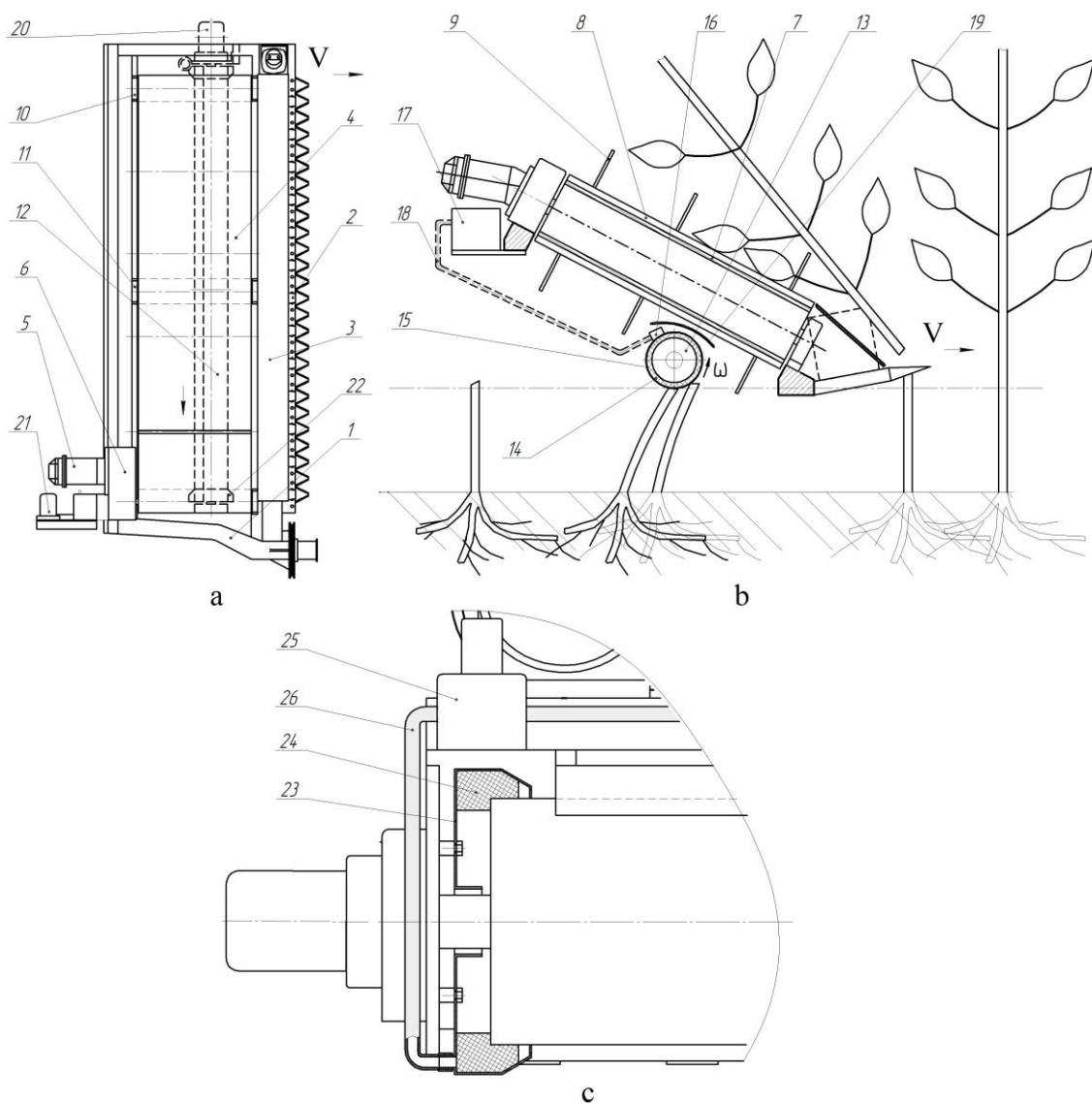

Fig. 1 - Scheme of the working tools of the contact action weeding mechanism

top view (a), working scheme (b), unused solution collector (c): 1-frame, 2-cutting device, 3-plate, 4-collector; 5-collector drive hydraulic motor; 6-collector drive gearbox; 7-conveyor belt; 8-cleat; 9-fingers; 10-tension mechanism; 11-supporters; 12-couplant mechanism; 13-drum; 14-porous-capillary material; 15-synthetic net; 16-feeder; 17-dosing pump; 18-pipe lines; 19-casing; 20-shaft drive; 21-pump drive; 22-unused solution collectors; 23-jar; 24-circle made of porous material; 25-draining pump; 26-pipe line

While in operation, the cut plants fall on the collector 4 and they are taken away; the drum 13 applies the herbicide solution directly on the cut plants by the couplant method. The herbicide moves to the plant root through the capillaries and causes their destruction or significant loss of vital functions without polluting the environment. The dosing pump 17 regulates the herbicide flow in order to ensure the supply of the necessary amount of herbicide and to avoid dropping.

The suggested construction has following advantages: possibility to destroy above ground part of the weeds and their roots, possibility to reuse the weed stems, selective action (only high plants are cut down, crop plants and grass are saved), ecological compatibility (chemicals that are used in solutions don't settle on the soil or crops), minimal non-productive losses (dropping, evaporation, wind).

According to the chosen topic, the authors research the kinetics of the weeding process in order to formulate the concept for further examining the weeding machine construction.

The authors study the technological process of weeding as the one that is done sequentially and consists of two technological operations: weeds stem cutting and herbicide application on the cut stems. As a result, we get two products – weed stubbles with herbicide applied on the top and cut weed stems on the field surface.

The authors examine the kinetics of weeding technological process in order to form the concept for further research of machine construction for contact weeding method. The analysis of the weeding process is done in accordance with the theory of biological populations' propagation and death (Sychuhov N.P., 1970; Ventsel E.S., 2003).

The authors regard the weeding process as homogenous, set in time and deterministic. The subpopulation of weed stems may be in the following states – cut but without herbicide covering (stubbles, non-covered); cut and covered with herbicide (stubbles, covered); non-cut covered with herbicide (stems, covered). These assemblages are characterized with initial and current inclusion in total weed amount on a certain field area. If these assumptions are correct, then the equation of material balance is true in any random moment of time:

$$Q(t) + Z(t) + \alpha(t) = Q_0 \quad (1)$$

where $Q(t)$ is the number of uncut plants that are not covered with the herbicide and remain on the field, $Z(t)$ is the number of uncut plants but covered with the herbicide, $\alpha(t)$ is the amount of cut and covered with the herbicide weeds, Q_0 is the total number of weeds before the beginning of the process.

The authors introduce the limitation for further research:

- in the initial moment of the process ($t=0$) $Q(t) = Q_0$;
- weed stems cutting is performed simultaneously with the herbicide application on the tops of the stubbles;
- the contact herbicide application process takes place under unchangeable environmental conditions.

We can write the differential equation of weeds number change on the processed area:

$$\frac{dQ(t)}{dt} = -k_1 \cdot Q(t) \quad (2)$$

where k_1 is the intensity of the weeds cutting process with the cutting unit of the contact action machine for weeding.

The number of weeds that are not cut but covered with the herbicide can be calculated with the help of the equation:

$$\frac{dZ(t)}{dt} = \frac{Q(t)}{dt} - \frac{d\alpha(t)}{dt} = k_1 \cdot Q(t) - \frac{d\alpha(t)}{dt} \quad (3)$$

The number of the stems where herbicide was applied is proportional to the number of cut and uncut stems:

$$\frac{d\alpha(t)}{dt} = k_2 \cdot Q(t) + k_3 \cdot Z(t) \quad (4)$$

where k_2 indicates the intensity of uncut stems processing and k_3 – the intensity of cut stems processing.

The indices k_1, k_2, k_3 can be defined experimentally or theoretically.

The equations for total change of weeds amount that was processed with the contact action machine are the following:

$$\left. \begin{aligned} \frac{dQ(t)}{dt} &= -k_1 \cdot Q(t) \\ \frac{d\alpha(t)}{dt} &= k_2 \cdot \frac{dQ(t)}{dt} + k_3 \cdot \frac{dZ(t)}{dt} \\ \frac{dZ(t)}{dt} &= k_1 \cdot Q(t) - (k_2 \cdot Q(t) - k_3 \cdot Z(t)) \\ \frac{dQ(t)}{dt} + \frac{d\alpha(t)}{dt} + \frac{dZ(t)}{dt} &= 0 \end{aligned} \right\} \quad (5)$$

We solve these equations.

The first equation of the system (5) shows the change in number of uncut weeds where herbicide was applied with the drum. The solution of this equation is:

$$\frac{dQ(t)}{Q} = -k_1 \cdot dt, \text{ hence } \ln Q(t) = -k_1 \cdot t + C \quad (6)$$

If we assume that $C = \ln C_1$, we will get $\ln Q(t) - \ln C_1 = -k_1 \cdot t$.

If the processing time $t=0$, then $Q(t) = Q_0$ and $C_1 = Q_0$, we have

$$Q(t) = Q_0 e^{-k_1 t} \quad (7)$$

The equation (7) is an exponential function. Before the start of the process $t=0$ $Q(t) = Q_0$. If the machine starts functioning moving along the field, the number of uncut stems covered with the herbicide reduces and tends to zero. The speed of herbicide application is determined by intensity (k_1). The variable k_1 depends on the design parameters of the machine and working regime. Also, the variable k_1 depends on the roughness and height of the weed stems.

The weed stems are processed by the cutting device knives in one second. The cutting device cuts m number of weeds in one second.

The cutting device cuts N stems on working width. According to (Letoshnev M.N., 1949):

$$N = t_0 h K \cdot 10^{-4} \quad (8)$$

where t_0 is the distance between the blades of cutting device, mm; h is delivery, cm; K is number of weed stems per m^2 , units.

We examine the key figures to evaluate the working quality of the machine for contact application.

For the evaluation of the process we take the key figures (the equations that we have got after the analysis of the functions above):

1. the number of unprocessed weed stems:

$$\varphi_u(t) = \frac{Q(t)}{Q_0} = e^{-k_1 t} \quad (9)$$

If $t=0$, we get $\varphi_u(t) = 1$.

2. the number of cut weed stems that are covered with herbicide – finish accuracy:

$$\text{taking the condition that } t=0 \varphi_u(t)=1, \text{ we get } \varphi_y(t) = 1 - \frac{Q(t)}{Q_0} = 1 - e^{-k_1 t}, \quad (10)$$

3. the number of destroyed weeds:

$$Y(t) = \frac{\alpha(t)}{Q_0} \quad (11)$$

If $t=0$, $Y(t)=0$.

The intensity coefficients K_1, K_2, K_3 do not show their complete dependence on design parameters and operation mode of the working tools of the contact action weeding machines. With this purpose, the authors establish general correspondences between plant stems and some parameters of machine working tools.

To calculate the intensity coefficient k_1 we assume that the cutting device effectively cuts on working width:

$$\lambda_1 = \frac{k_1 \cdot t}{N}, \text{ or } \lambda_1 N = k_1 \cdot t \quad (12)$$

If we assume that the cutting effectiveness on each area is the same, we will have an equation for finish accuracy (10):

$$\varphi_y(t) = 1 - e^{-\lambda_1 \cdot N} \quad (13)$$

Here we see that the cutting device is determined by the effectiveness index on a certain area. The higher λ_1 is, the faster φ_y becomes maximal.

On the other side, the process effectiveness is determined by the number of weed stubbles covered with herbicide. The drum contacts with m cut stems in one second:

$$m = \frac{L_d \omega_d}{2\pi \cdot v_m} \quad (14)$$

where L_d is the drum length, m; ω_d is its rotational speed, c^{-1} ; v_m is the machine speed, m per s.

We calculate the intensity of weeds cutting k_1 . We solve the equations (7), (9), (12). According to (12) we write the equation for finish accuracy (10):

$$\varphi_y(N) = 1 - e^{-\lambda_1 \cdot N} \quad (15)$$

Then the equation $\varphi_y(N) = 1 - \varphi_u^N$ is true (according to (14) and (15)) if the whole length of the cutting device cuts.

We get:

$$\varphi_y(N) = 1 - e^{-k_1 \cdot N} \text{ and } \varphi_u(N) = e^{-k_1 \cdot N} \quad (16)$$

Taking into consideration this equation and transformation (7), (9), (12), we can calculate:

$$k_1 = -\frac{\ln \varphi_y(N)}{t}, \quad (17)$$

where t is the processing time, s.

$\varphi_y(N)$ is determined in experimental way.

RESULTS

The effectiveness of the weeding process by suggested contact action machine can be evaluated with k_1 , that is the process intensity. It is a physical quantity that describes the kinetics of the process.

CONCLUSIONS

The above-mentioned equations (4), (9), (11), (12), (14) allow to formulate the concept of further research: explain the main parameters of the contact application machine in accordance with the physical and mechanical characteristics of the stems, namely roughness, cutting height, weed stems diameter that depends on the development stage of the weed. It allows providing the effective work of the suggested equipment.

REFERENCES

- [1] Bundza O.Z., Kravets S. V., Nalobina O. O., Nikitin V. G., (2015), Theoretical reasoning of the couplant equipment drum position respectively the cut plants, *INMATEH-Agricultural Engineering*, vol.46, no 2., pp. 95–100, Bucharest/Romania;
- [2] Bundza, O.Z.& Nikitin, V.H., (2010), *Equipment for plant and weed destruction*, Patent, No. 47259, Ukraine;
- [3] Joseph M. DiTomaso., Drewitz J., (2008), Jubatagrass (*Cortaderia Jubata*) control using chemical and mechanical methods, *Kyser invasive plant science and management*, vol.1, no.1., pp. 82–90, Davis/California;
- [4] Kotov A.A., (2009), Research of solution losses from the working tool surface of the contact herbicide machine (Исследование потерь препарата из покрытия рабочего органа контактной гербицидной машины), *Annals of the Moscow State University*, no.2, pp. 124–128, Moscow;

- [5] Kotov A.A., (2009), *Technology perfection and creation of new mechanisms for forest nurseries and forest crops*, Phd. Eng. dissertation, Moscow State Forest University/ Russia;
- [6] Lemus R., Mowdy M., Davis A., (2013), Herbicide evaluation for Smutgrass control using the weed wiper method, *Journal of the American Society of Farm managers and rural appraisers*, Vol. 6., issue 1, Mississippi State / U.S.A.;
- [7] Letoshnev M.N., (1949), *Agricultural machines. Theory, calculation, design, tests (Сельскохозяйственные машины. Теория, расчет, проектирование и испытание)*, "State publishing of agricultural literature", Moscow – St.Petersburg, 856p;
- [8] Lvov S.M., Putianin Y.P., Shashova M.V., (1990), Contact method of herbicide and arboricide application, *Forest Management*, no. 12, p.45-50;
- [9] Lysov A.K., (2009), Reduction of the pesticide losses during spraying (Снижение потерь пестицидов при опрыскивании), *Agricolist*, no. 2, p.138, Kyiv / Ukraine;
- [10] Lysov A.K., (2012), New technology for plants spraying (Новая техника для опрыскивания растений), *Plants protection and quarantine, Agricolist*, no.5, pp. 55 – 57, Kyiv / Ukraine;
- [11] Melezhyk O.I., (2010), *Improvement of pesticide spraying dispersion (Покращення дисперсності розпилення пестицидів)*, PhD Science Thesis, National university of bio-resources and natural use of Ukraine, Kyiv / Ukraine;
- [12] Moyo C., Harrington K. C, Kemp P. D, Eerens J. P., (2008), Herbicide deposition on weeds from weed wipers, *New Zealand Plant Protection*, (vol.61), p. 395, Henderson/ New Zealand;
- [13] Onyschenko B.V., (2011), Explanation of the spraying device with the step-type dispersion controller (Обґрунтування розпилювального пристрою обприскувача з ступеневим регулюванням дисперсності розпилення), PhD Science Thesis, National University of Life and Environmental Sciences of Ukraine, Kyiv / Ukraine;
- [14] Sychuhov N.P., (1970), *Pneumatic transport mounting. Classification, theory, calculation of principal blocks and examples of mounting calculations (Установки пневматического транспорта. Классификация, основы теории, расчет основных узлов и пример расчета установки)*, Moscow, p. 68;
- [15] Thomas J. Monaco, (2002), *Weed science. Principles and Practices*, John Wiley & Sons.inc., 685p., New York/U.S.A.;
- [16] Ventsel E.S., (2003), *Theory of probability and its application in engineering (Теория вероятностей и ее инженерные приложения)*, "Publishing centre "Academy", p. 464;
- [17] ***Weed wipers (2014). Available at: <http://www.smuckermfg.net/pages/weedwipers.aspx> (Accessed: 28 March 2015).