

DEVELOPMENT OF AN ELECTRO CHEMICAL MACHINE SET-UP AND EXPERIMENTATIONS

Aniket Jadhav¹, Kishor D. Patil², D. B. Jadhav³, W. G. Kharche⁴

¹M.Tech.Student, Mechanical Engineering Department, B.V.D.U.C.O.E. Pune, India
E-mail:-sananiketjadhav@gmail.com, Contact no.:- 7875610000

²Student, Mechanical Engineering Department, B.V.D.U.C.O.E. Pune, India

³Assistant Professor, Mechanical Engineering Department, B.V.D.U.C.O.E. Pune, India

⁴Principal, Bharati Vidyapeeth's J.N.I.O.T, Pune, India

Abstract:- Electro chemical machining (ECM) process is a non-traditional machining process. The material which is difficult to cut by conventional machining process, such kind of materials also machined by ECM. Electro chemical machine can also machine the complex shapes easily. The few common applications of Electro chemical machining are- machining fuel injection system components, aerospace components, dies, moulds etc. The paper is based on the set up development. The modeling of different components required for the set-up, preparation of manufacturing diagrams and actual manufacturing of components. The experiments are performed for the confirmation. The experimentations carried out under different pressure and feed rate. The results are physically observed. The maximum overcut observed is 0.80mm when the tool diameter is 4 mm and minimum overcut produced is 0.61mm.

Key words:- New ECM set-up, mechanical system, electric system, hydraulic system, overcut.

Introduction:

Machining of the hard material is the big challenge in the manufacturing processes. The material, which is difficult to machine under conventional machining processes, such materials are machined by non-conventional machining processes and also the ECM is most frequently used when shaped cavities are machined in to alloys that are difficult to shape by conventional methods. Electrochemical machining process is one of the most potential non- conventional machining processes. Tool and work piece are free of stress. It doesn't have any physical contact during the machining process. So the soft material can be used as the tool material compare to work-piece material. Only the electrically conductive materials are machined in ECM. So both the tool and work piece should be electrically conductive. There is no any thermal damage during machining because electrolyte carries the heat from the machining area under continuous circulation. ECM have a major advantages compare to other like no tool wear, not thermal stress, unaffected by hardness of the material [1].

Electrochemical machining process is based on the principle of electrolysis for material removal. The ECM is a process of material removal by anodic dissolution under controlled process parameters. The tool is connected to the negative terminal known as cathode and work piece is connected to the positive terminal is known as anode. Both the cathode and anode are keep separate by the small gap is known as inter electrode gap (IEG). IEG is filled by the electrolyte under continuous circulation. The metal is removed in the form of sludge and precipitates by electro-chemical and chemical reactions. This is occurred in the electrolytic cell. The material from the work piece is removed due to the continuous tool feed.

This study is related to the set-up development and practically observes the effect of the pressure and feed rate variation under constant voltage on the overcut and analyzes the circular profile of the machined component.

Working principle:

ECM removes the material under controlled anodic dissolution in the electrolyte. The dissolution starts, when the current flows between tool (cathode) and work piece (anode) through electrolyte. On the basis of Faraday’s law of electrolysis, the materials get removed (dissolved) from the work piece. Faraday’s two laws govern the electrolysis process [2, 3].

1. The amount of chemical change produced by an electric current, that is, the amount of any material removed, is proportional to the quantity of electricity passed[2,3].
2. The amounts of different substances dissolved by the same quantity of electricity are proportional to their chemical equivalent weights [2,3].

During the electro chemical machining, as potential difference is applied across the electrodes. The electrolyte and water undergoes ionic dissociation and different chemical reactions take place, ultimately removing some metal from anode surface. Let us consider a work piece of ferrous material which contains lower percentage of carbon and Sodium chloride is used as an electrolyte, when the potential difference is applied between the work piece and tool.

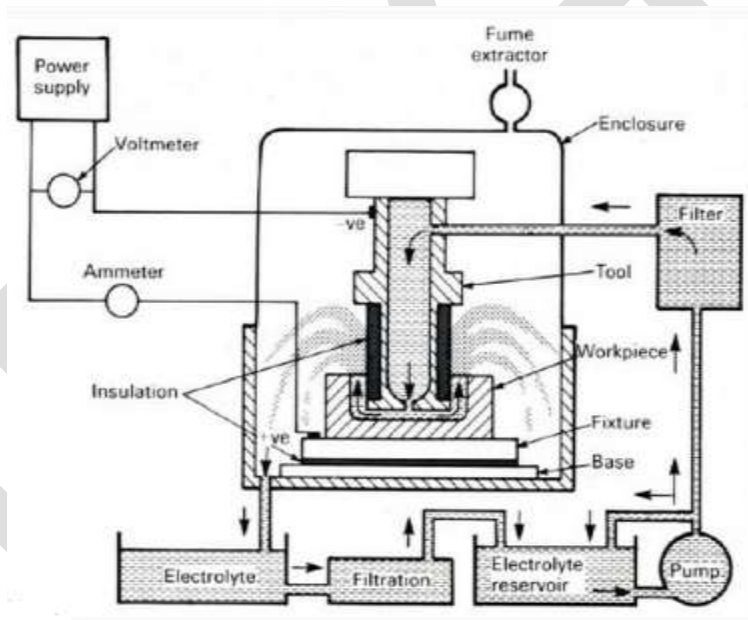
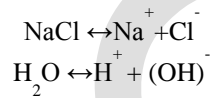
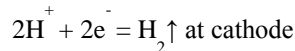
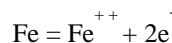

Figure 1. Schematic set-up of ECM [6]

The positively charged ions get attracted (move) towards the tool and negatively charged ions move towards the work piece, Thus the hydrogen ions will take away electrons from the cathode (tool) and from hydrogen gas as:



Similarly, the iron atoms will come out of the anode (work piece) as:



Within the electrolyte iron ions would combine with chloride ions to form iron chloride and similarly sodium ions would combine with hydroxyl ions to form sodium hydroxide

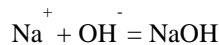

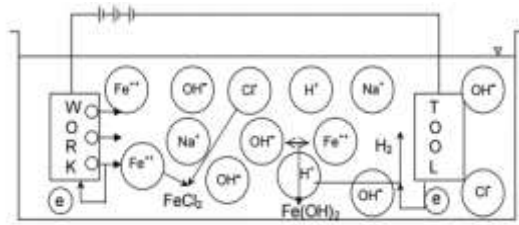

Figure 2: Representation of chemical reaction in ECM[4]

In practice $FeCl_2$ and $Fe(OH)_2$ would form and get precipitated in the form of sludge. In this manner it can be noted that the work piece gets gradually machined and gets precipitated as the sludge. There is no coating on the tool, only hydrogen gas evolves at the tool or cathode [4,5].

NEWLY DEVELOPED ECM SET-UP:

INTRODUCTION

The papers suggested that the response of a system is affected by the process parameters. The voltage, feed rate, pressure, flow rate, inter electrode gap, concentration of electrolyte and type of electrolyte etc. need to be control for good performance of process. So the important consideration during the setup development is to control the process parameters during machining and study the effect on the response of a system. To control the linear movement of a tool and tool feed rate is most important task while developing the mechanical system. 3D CAD model of mechanical system is prepared by using pro-e wildfire 5.0. The manufacturing drawings are prepared for manufacturing the components and the standard components are drought from the market. Mechanical system is made by assembling the manufactured and standard components. The three different systems get combined for the ECM set-up. Three systems are hydraulic, electrical and mechanical system. Electrolyte flow rate is controlled by hydraulic system. The voltage and tool feed rate is controlled by electric system. For better aesthetic look, all machined components were blackodized.

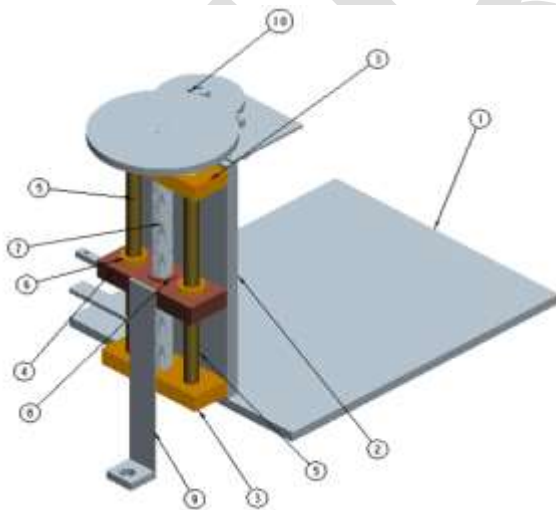

Sr. no.	Part name	Quantity
1	Base plate	1
2	Vertical plate	1
3	Holding blocks	2
4	Movable block	1
5	Guide bar	2
6	Linear ball bearing	2
7	Screw	1
8	Collar nut	1
9	Tool holder	1
10	Plastic gear	4

Figure3. CAD model of ECM set-up

Linear tool movement arrangement:

Movement of the tool during machining process is most important. It should move linearly up and down. Linear tool movement and tool shape decides the face profile of machined component. Proper guiding is required to get the linear tool movement. The aluminium block with two linear ball bearing and collar nut is properly guided by the guide bars. Collar nut moves up and down when the square threaded screw rotates by means of external device (DC motor). Ultimately aluminium block starts to move up and down. Dial gauge is attached with movable block by means of aluminium plate. Dial probe touches the plate and plate moves up and down over the guide bar and clamp at required place by using bolt. Dial gauge shows the distance travelled by the tool or aluminium block.

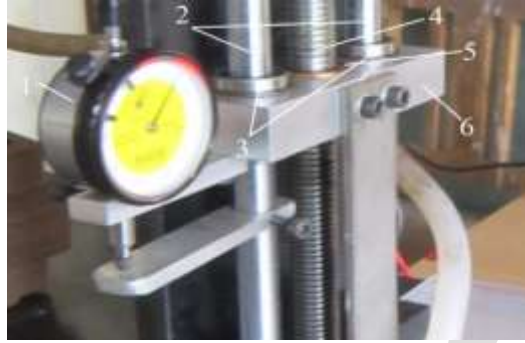

1. Dial gauge. 2. Guide bars, 3. Linear ball bearings, 4. Square threaded screw, 5. Collar nut, 6. Aluminium block

Figure4. Guiding and moving arrangement for tool

Tool holding arrangement:

Tool actually holds inside the machining chamber. So for that we required one aluminium plate whose one side is attached to movable block and at other end horizontal aluminium plate is attached. Tool is actually holds inside acrylic plate and finally acrylic plate is mount on the horizontal aluminium plate. Due to this the leakage of current is avoided.



1. Electrolyte inlet, 2. Electrolyte outlet

Figure5. Tool holder

Speed reduction arrangement:

Speed reduction arrangement is required to reduce the speed for achieving the required tool feed rate. DC motor of speed 10RPM is used to achieve the linear speed of 0.7mm/min. Two spur gear pairs are used for the speed reduction. The four gears are used having teeth of 10, 60, 15, and 100. First gear pair having teeth of 10 and 60. Second gear pair having teeth of 15 and 100



Figure6. Gear arrangement for speed reduction.

Machining chamber:

Machining chamber made up of plastic material. It occupies the tool and work piece. Plastic vice is used to clamp the work piece and is placed inside the machining chamber. Plastic material is used because the electrolyte is a corrosive material.



Figure7. Machining chamber

DC motor:

DC motor is used to provide a required rotary motion. Dc motor gives 10 rpm speed at 12V. But practically it gives more speed as the current varies. 12V, 1A DC adapter is used to run the motor. So, required DC motor speed is achieved by providing electric circuit.



Figure8. DC motor

Electrical system:

DC power supply of 0-30V and 0-20A is used. The positive and negative output of DC power supply is connected to the work piece and tool respectively. Power from the adapter is supplied to DC motor through an electric circuit. The electric circuit is used to vary the speed of dc motor. The input current of a DC motor is varied by using the potentiometer.. The following figure shows electric circuit control panel.



1. ON/OFF switch
2. forward/reverse switch
3. auto/manual switch
4. Current setting pot
5. Speed control pot

Figure 10. Actual electric circuit for speed control

Hydraulic system:

Hydraulic system is used to control the flow rate of electrolyte in electro chemical machining. The flow rate is varied by varying the electrolyte pressure. Electrolyte tank stores the electrolyte solution under sufficient quantity. The centrifugal pump is used to supply the electrolyte from the tank to machining area through the pipes. The bypass connection with flow control valve is used to control the input electrolyte pressure. Pressure gauge shows the electrolyte inlet pressure. Outlet of the hydraulic system is connected to the tool inlet through the centre hole of tool it passes to machining area. Plastic pipes are used for the system.



1. Electrolyte tank
2. Pump
3. Bypass connection
4. Bypass valve
5. ON/OFF valve
6. Pressure gauge
7. Input pipe

Figure 11. Hydraulic system

Tool and work piece:

Tool is made up of brass material and stainless steel material is used as a work piece material. Following table shows the chemical composition of selected work piece material

Table1. Chemical composition of work piece

Sample	Chemical composition %							
	C	Mn	Si	S	P	Cr	Ni	N
SS	0.08	2.0	0.75	0.030	0.045	18	8	0.10

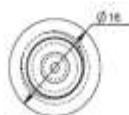
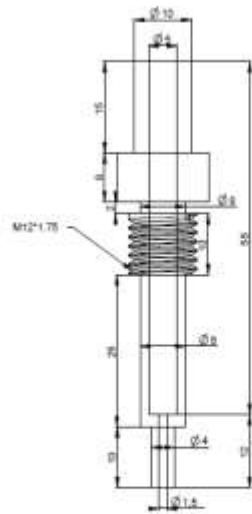

ALL DIMENSIONS IN MM



Figure12. Tool and work piece

Experimentation:

The tool and work piece are placed inside the machining chamber. Both are separated by small gap (0.3mm) is known as inter electrode gap. The power supply is connected to the tool (cathode) and work piece (anode). NaNO_3 electrolyte is used to fill a inter electrode gap under continuous circulation. The electrolyte is supplied to the machining area through hole which is at the centre of the tool. It carries current between tool and work piece when the voltage applied across the two electrodes. After that start the tool feed under controlled action. Tool movement towards work piece actually removes the material. The material is removed in the form of sludge and electrolyte removes the sludge from the machining area. The experimentations are performed for the set up validation and check the overcut produced under the feed rete and pressure variation by keeping the voltage constant.

Table2. Parameters and its levels

Parameters	Unit	Nomenclature	Low(-1)	High(+1)
Voltage	V	A	12	14
Feed rate	mm /min	B	0.4	0.6
Pressure	Bar (kg/cm^2)	C	2.0	2.5

Experimental results:

All the possible experiments are performed under controlled process parameters. Observe and note down the response.

Table3. Experimental results

Experiment no	Voltage	Feed rate	Pressure (bar)	Overcut (mm)
1	12	0.4	2.0	0.67
2	12	0.4	2.5	0.80
3	12	0.6	2.0	0.61
4	12	0.6	2.5	0.75



Figure13. work piece after machining

Conclusion:

A setup has been developed for the electro chemical machining process investigation. The validation experiment is done on 1 mm stainless steel plate. The maximum overcut produced is 0.80 mm when the parameters set as voltage 12V, feed rate 0.4mm and electrolyte pressure 2.5 bars. The overcut is increased as the pressure increases and feed rate decrease. The minimum overcut (0.61mm) is produced when the parameters set as voltage 12V, feed rate 0.6mm and electrolyte pressure 2.0 bars.

REFERENCES:

1. "Parametric Optimization of Electrochemical Machining Using Signal to Noise Ratio" By Bhawna Bisht, JyotiVimal, Vedansh Chaturvedi. International Journal of Modern Engineering Research. Vol. 3, Issue 4, Jul-Aug 2013.
2. Ghosh, A. And Mallik, A.K., (2010). Manufacturing Science Second Edition, East- West Press Private Limited, New Delhi, India. Page 354-383
3. "Unconventional Machining Manufacturing Processes" By M.K. Singh. New Age International Publiahers
4. Module 9 "Non-Traditional Machining" Lesson 38 Version 2ME IIT.
5. "Experimental Study On Parametric Optimization of Titanium Based Alloy (Ti-6al-4v) In Electrochemical Machining Process" By Pravin D. Babar, Baliram R. Jadhav. International Journal of Innovation in Engineering and Technology. Vol 2, Issue 2 April 2013.
6. J. A. McGeough, principal of electrochemical machining. Chapman and hall, London.