



## Design procedure for ductile tension-only seismic bracing with an energy dissipation ring

Dejan Erdevicki \*

*Erdevicki Structural Engineering, 4205 Musqueam Drive, Vancouver V6N 3R8, Canada*

### ABSTRACT

This paper will present a design solution for a ductile, tension-only seismic bracing with the use of an energy dissipating ring. This type of bracing behaves very well under seismic loading and has shown, by testing carried out in conjunction with the University of British Columbia, that it can reach very high post elastic drift limits. The presented procedure is a method created by the author and is based on information collected during the research testing program performed by the Civil Engineering Department at the University of British Columbia. The team was led by Professor Carlos Ventura, in collaboration with Dejan Erdevicki from Erdevicki Structural Engineering. The presented design procedure describes the behaviour of the system, the relation between energy, forces, drift limits and capacities of the ring. It also includes geometrical limitations and requirements for the ring element and bracing system, to ensure that target drifts can be achieved. It allows the user to calculate seismic forces and reduction factors based on an energy criterion and the chosen final drift of the structure. For longer period structures, an equal displacement principle is discussed and considered. The procedure can be used for seismic capacity design and is easily adjusted to suit applicable national codes. Ring capacity tables and examples are also included. This ductile, tension-only bracing, with an energy dissipating ring, can be used for new structures, as well as for the retrofit of existing ones. The system is relatively simple and allows for easy replacement of the ring after an earthquake event if needed. The application of the bracing system for buildings, including multi-storey structures, will be discussed.

### ARTICLE INFO

#### *Article history:*

Received 8 December 2015

Accepted 12 February 2016

#### *Keywords:*

Seismic bracing

Energy dissipation ring

Drift limit

Seismic design

Multi-storey structures

### 1. Introduction

The tension-only bracing illustrated in Fig. 1 is a simple and ductile bracing system that can be used as a seismic load-resisting structural element. The design procedure presented in this paper is a conservative method created by the author, based on the information collected during a series of tests on a full-scale braced frame carried out at the University of British Columbia. The testing program included quasi-static, cyclic and shake-table tests. Work on this research project started 2007 and most of the tests were performed from 2011 to 2013. The test program was performed at the UBC Earthquake Engineering Laboratory by a research team led by Professor

Carlos Ventura, in collaboration with Dejan Erdevicki from Erdevicki Structural Engineering.

The test program was limited to 45 degree diagonals and one-storey bracing. The author is confident that the procedure can be used also for multi-storey bracing systems. The optimal angle for diagonals is 45°. Until further test results are conducted, the author recommends restricting the angle of diagonal bracing  $\alpha$  to between 40° and 50°.

The system will dissipate energy by forming plastic hinges inside the central ring. Control of the number of hinging points and their locations is achieved using clamp plates. The design procedure presented in this paper is valid only if all the requirements for the ring and system design described below are fulfilled.

\* *Corresponding author.* Tel.: +1-604-880-1720 ; E-mail address: erdevicki@telus.net (D. Erdevicki)  
ISSN: 2149-8024 / DOI: <http://dx.doi.org/10.20528/cjsmec.2016.02.003>

Nomenclature	
$A$	length of clamp plates, mm
$A_{eq}$	effective rod cross sectional area, mm <sup>2</sup>
$A_r$	rod cross sectional area, mm <sup>2</sup>
$B$	width of ring, mm
$C$	dimension between clamp plates, mm
$D_{eq}$	equivalent diameter of rod, mm
$D_i$	internal diameter of ring, mm
$D_o$	external diameter of ring, mm
$E$	modulus of elasticity of steel, MPa
$F_u$	tensile strength of ring material, MPa
$F_y$	yield strength of ring material, MPa
$H$	horizontal force, kN
$H_{el}$	elastic seismic horizontal force, kN
$H_{ov}$	overstrength horizontal force, kN
$H_y$	horizontal force causing yield, kN
$h$	height of braced frame, mm
$h_i$	height of $i^{\text{th}}$ floor in multi-storey frame, mm
$K$	initial elastic stiffness of bracing, kN/mm
$K_r$	elastic stiffness of ring, N/mm
$L_d$	length of diagonal, mm
$M_f$	factored bending moment at a section, kNmm
$M_{f\ wind}$	factored bending moment for wind at a section, kNmm
$M_r$	seismic flexural resistance at a section, kNmm
$M_{rw}$	factored flexural resistance for wind at a section, kNmm
$R_o$	material factor as specified in the applicable design code
$R_d$	ductility factor as described in Section 6
$T_1$	first natural period of vibration, sec
$t_r$	thickness of ring, mm
$t_w$	clamp plate thickness, mm
$X, Y$	sections of peak ring flexure
$Z$	diagonal force, kN
$Z_{el}$	elastic seismic rod tension force, kN
$Z_f$	factored rod tension force, kN
$Z_{f\ wind}$	factored rod wind force, kN
$Z_r$	ring factored tension resistance, kN
$Z_{r\ wind}$	ring factored tension wind resistance, kN
$Z_y$	ring yield tension capacity, kN
$\delta$	horizontal deformation corresponding to $H$
$\delta_{el}$	elastic horizontal deformation
$\delta_{max}$	maximum horizontal deformation
$\delta_y$	horizontal deformation causing yield
$\Phi$	hole diameter, mm

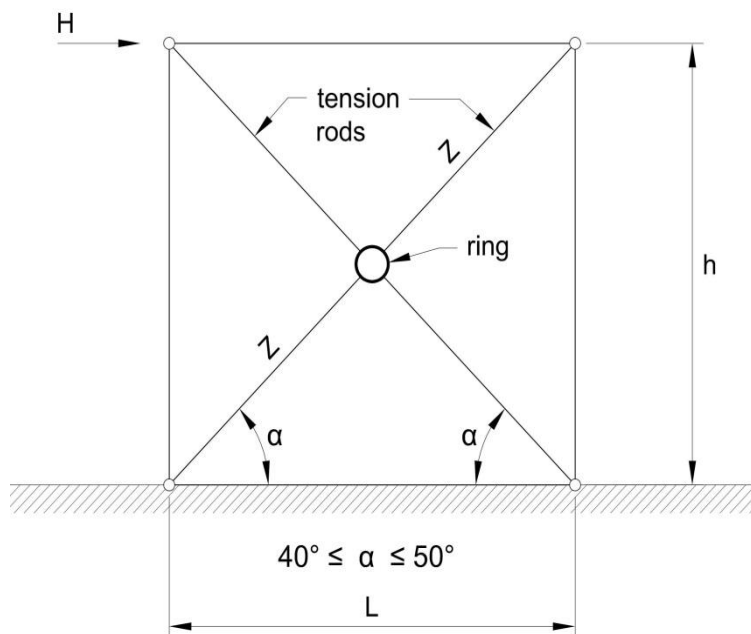

Fig. 1. Bracing system.

## 2. Ring General Requirements

The ring and washers are generally as shown in Fig. 2.

Based on current testing following geometric requirements are suggested:

- $Di > 142 > h / 21$
- $tr \geq 7$
- $B > 90 > 4 * \phi$

The minimum tested inside ring diameter  $Di$  was 149 mm for a frame height of 3160 mm ( $h / Di = 21.2$ ). Larger rings performed better as the post-elastic frame deformation for all quasi-static tests was limited to the same drift of  $0.015 * h$ . For that reason it is suggested that  $Di > h / 21$  and  $Di > 142$  mm. All tested rings were 90 mm wide and had 22 mm holes ( $B / \phi = 4.1$ ). The suggested  $B / \phi$  ratio is to limit the ring net-section reduction.

When tested, rings without double clamp plates fractured at the hole locations, whereas rings with double clamp plates fractured at the edges of the clamp plates and performed much better in the tests. All tested clamp plates were 50 mm long, 19 mm thick and had 22 mm diameter holes. These clamp plates worked well for overstrength diagonal loading of about 110 kN.

Making the clamp plates too narrow or too thin will reduce the clamp plate capacity and would impair ring performance. The clamp plates should remain elastic in resisting overstrength loading and should be capable of distributing the load evenly across the width of the ring. In addition, the clamp plates should not be too long in order to maximize the post-elastic deformation capacity of the rings. The minimum  $Di / A$  ratio tested was 2.98. The proposed  $Di / A$  ratio are therefore  $>3.0$ .

The following geometric limits are proposed, but could be varied in the light of satisfactory test results:

- $A \leq Di / 3, \geq 50, \geq 2 * \text{rod diameter}, \geq Do / 6$
- $tw > 19, > B / 5, > 0.4 * A, > 1.25 * tr$
- Clamp plate radius to match inside and outside ring radius.
- Clamp plate corners to be chamfered 2-3 mm.
- Clamp plate material to be as strong, or stronger than the ring material.
- Ring and clamp plate holes are to be 2 mm larger than the rod diameter.
- Rod nuts and lock washers to be placed on the inside and outside of the ring.



## 3. Ring Capacity, Factored Loading and Overstrength Factor

The following simplified relationship between the rod tension force and ring moments can be used:

$$Mf = 0.3 * Zf * C \quad \text{or} \quad Zf = Mf / (0.3 * C) \quad \text{Eq. (4.1)}$$

where

$$C = (Do - tr) / 2 - A / 2 + 5 \text{ mm}$$

Numerical modeling of the ring and clamp plates would be another way to determine the maximum moment at Section X.

### 3.1. Non-seismic loading

For non-seismic loading, the ring bending resistance at Section X should be calculated based on the applicable steel design code, using the gross section  $B * tr$  without reduction for the hole. The suggested ULS stress limit is  $0.9 * Fy$ .

The capacity check at Section Y is not critical, as the section tension capacity is significantly larger than the corresponding moment capacity, and the initial moment at Section Y is only about 67% of the corresponding moment at Section X.

### 3.2. Seismic loading combinations

For seismic design, the following ring resistance can be used:

$$Mr = My = 1 / 6 * Fy * B * tr^2 \quad \text{and} \quad Zr = Zy = Mr / (0.3 * C) = 1 / 6 * Fy * B * tr^2 / (0.3 * C) \quad \text{Eq. (4.2)}$$

- The seismic design requirement will be:
- $Mr \geq Mf$  or  $Zr \geq Zf$
- $Mf$  can be calculated using the design factored tension rod force  $Zf = Zel / (Rd * Ro)$ .
- $Zel$  = elastic diagonal ULS seismic force corresponding to  $Hel$  calculated using the applicable building code.
- $Ro \leq 1.5, Ro = 1.5$  is recommended.

The overstrength ring capacity will exceed the tensile strength of the material,  $Fu$  and the ring will gain significant post-elastic capacity through shape change. Based on experimental results, the maximum ring overstrength could be between 2.0 and 2.5. The author suggests using an overstrength factor of 2.5 for design of all connections, tension rods, and affected structural bracing elements and foundations. The overstrength factor for rings larger than 210 mm could be reduced to 2.0.

### RING DETAIL

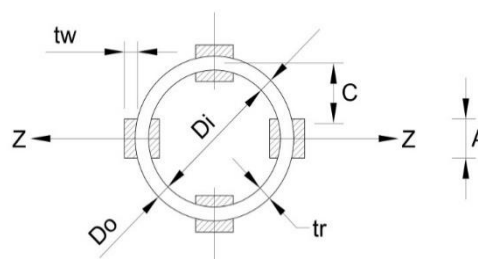

Fig. 2. Ring geometry

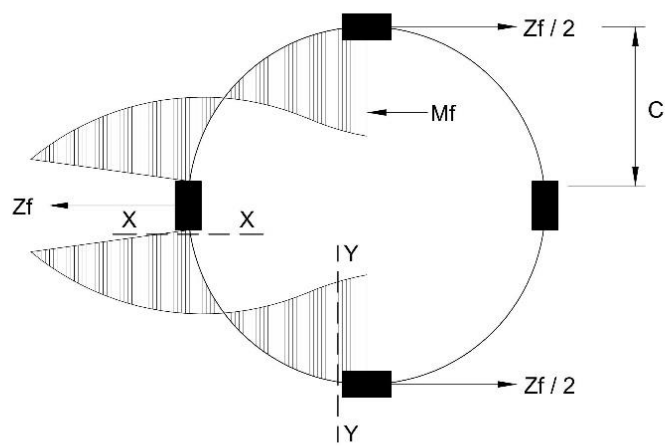

**Fig. 3.** Ring without double clamp plates.



**Fig. 4.** Ring with double clamp plates.

**RING MOMENTS**



$$M_f = 0.6 \times C \times Z_f / 2 = 0.3 \times C \times Z_f$$

**Fig. 5.** Ring moments.

### 3.3. Example and capacity table

**Table 1.** Ring capacity table.

Ring	$D_o$ (mm)	$t_r$ (mm)	$B$ (mm)	$F_y$ (Mpa)	$A$ (mm)	Seismic Capacity $Z_r$ (kN)
168/8	168	8	100	350	50	21
168/9.5	168	9.5	100	350	50	30
168/11	168	11	100	350	50	40
168/13	168	12.7	100	350	50	54.5
219/8	219	8	100	350	50	14.5
219/9.5	219	9.5	100	350	50	20.5
219/11	219	11	100	350	50	28
219/13	219	12.7	100	350	50	37.5
219/16	219	16	100	350	50	61
219/22	219	22	100	350	50	120
219/25	219	25.4	100	350	50	163
273/8	273	8	100	350	60	11.5
273/9.5	273	9.5	100	350	60	16.5
273/11	273	11	100	350	60	22
273/13	273	12.7	100	350	60	30
273/16	273	16	100	350	60	48
273/22	273	22	100	350	60	94
273/25	273	25.4	100	350	60	127
324/11	324	11	100	350	60	18
324/13	324	12.7	100	350	60	24
324/16	324	16	100	350	60	38.5
324/22	324	22	100	350	60	75
324/25	324	25.4	100	350	60	101
356/13	356	12.7	100	350	75	22.5
356/16	356	16	100	350	75	36
356/22	356	22	100	350	75	70
356/25	356	25.4	100	350	75	94.5

### 4. Bracing Stiffness

The initial elastic bracing stiffness  $K = H / \delta$ .

The bracing stiffness is important in estimating the ductility factor  $R_d$  and should therefore be carefully determined. The bracing should be modeled with one diagonal only and should include the ring.

Alternatively, the ring stiffness  $K_r$  from Table T2 can be used to calculate the required effective diagonal cross sectional area  $A_{eq}$  and to model only the diagonal without the ring using  $A_{eq}$ .

$$A_{eq} = A_r * L_d / (A_r * E / K_r + L_d - D_o) \quad \text{Eq. (5.1)}$$

Example:

- $L_d = 4500$  mm
- $A_r = 380$  mm<sup>2</sup> (for 22 mm diameter rod)
- Ring size: 324/25.4
- $K_r = 55$  kN/mm (from Table T2) = 55 000 N/mm
- $E = 210$  000 MPa
- Required equivalent diagonal cross section:
- $A_{eq} = 380 * 4500 / (380 * 210000 / 55000 + 4500 - 324)$
- $A_{eq} = 303$  mm<sup>2</sup>

Or, equivalent rod diameter  $Deq = 19.7$  mm.

The bracing should be modeled with one diagonal rod using an equivalent rod diameter of 19.7 mm.

The ring stiffness  $Kr$  for thicknesses not listed in Table T2 could be estimated using a ring of the same diameter and adjusting the stiffness using the  $tr^3$  ratio.

Example:

For the 219/16 ring, a thinner ring with the same diameter, 219/13 will be used. For the 219/13 ring, from Table T2,  $Kr = 24$  kN/mm. Therefore, for the 273/16 ring,  $Kr = 24 * 16^3 / 13^3 = 44.7$  kN/mm.

If the designer wishes to increase the bracing stiffness or capacity, it can be done by increasing the rod diameter, or by using multiple rods as shown in Fig. 8, in which case the ring should satisfy the geometric requirements described in Section 3.

## 5. Energy and RD

### 5.1. Systems with the first period of oscillation $T1 < 0.5(s)$

An energy criterion will be used to establish the ductility factor  $Rd$  as shown in Fig. 9. Test results have verified that diagonal tension-only bracing with a central ring can reach a post-elastic drift limit of at least 1.5 %. In addition, it was also evident that the system overstrength factor is higher than the  $Fu / Fy$  ratio. The overstrength area  $\Delta E1$  is larger than the area  $\Delta E2$  for  $\delta y < 0.0075 h$ , and is used to compensate for the  $\Delta E2$  area, and allow for simplification of the formula for  $E1$  shown in Fig. 9.

As a result:  $Rd = 2 * K * \delta max / Hel$  Eq. (6.1)

Substituting  $Hel / \delta el$  for  $K$ :  $Rd = 2 * \delta max / \delta el$  Eq. (6.2)

$Hel$  = The elastic seismic force calculated using the applicable building code

$\delta el$  = elastic force displacement

$\delta max = 0.015 * h$  = maximum displacement limit

Suggested  $Rd$  Limits:

$2.0 \leq Rd \leq 5.0$

It is important to note that the  $Rd$  factor can be increased using higher stiffness  $K$ , and will be reduced for a higher elastic force.

Example:

- $Hel = 100$  kN
- $K = 5$  kN/mm
- $h = 3000$  mm
- $\delta max = 0.015 * 3000 = 45$  mm
- $Rd = 2 * 5 * 45 / 100 = 4.5$
- Or using  $Rd = 2 * \delta max / \delta el$
- $\delta el = 20$  mm
- $Rd = 2 * 45 / 20 = 4.5$

Therefore, if the system is properly modelled and the elastic seismic forces are applied, the factor  $Rd$  is the ratio between the maximum chosen displacement and the elastic displacement.

### 5.2. Systems with a first period of oscillation $T1 > 0.5(s)$

The generally accepted the equal displacement principle shown in Fig. 10 can be used as an alternative to the

previously described approach. Further testing will be required to verify that the equal displacement principle is adequate and to establish a realistic limit to the force reduction factor.

An important limitation of the system in this case is that the elastic force displacement  $\delta el$  must be  $< 0.015 * h$ . If the designer decides to use the equal displacement approach, the author suggests limiting the force reduction factor  $Rd$  to 5.0.

## 5.3. Multi-storey systems

The force reduction factor,  $Rd$  can be checked at each storey level using the elastic seismic shear force at that level and corresponding  $K$  and  $\delta max = 0.015 * hi$  at that level.  $Rd$  can also be determined by calculating the elastic displacements at each level and using Eq. (6.2). See Fig. 11 for more details.

Ring ductility should be used at each floor level and should be designed with respect to design seismic shear force at that level. Further research should be undertaken on the behaviours of the multi-storey system to ensure that the plastic behaviour is not concentrated at the lower storey, but is distributed throughout.

## 6. Design Procedure for Systems with $T1 < 0.5$ s

- Design the ring and bracing for non-seismic loading.
- Calculate the first period  $T1$ , and system stiffness,  $K$ .
- Calculate the elastic seismic force  $Hel$  based on the applicable design code.
- Calculate  $Rd$  as described in Section 6.
- Calculate the seismic design force  $Hf = Hel / (Rd * Ro)$ .
- Calculate the corresponding diagonal force  $Zf$ .
- Design the ring as described in Section 4.
- Check the stiffness  $K$  based on the chosen ring size, and if  $K$  is lower than initially assumed, repeat the above procedure. If the chosen ring is stiffer than initially assumed, the system is safe in the case that it does not affect the force  $Hel$ . The designer can elect to refine the design or not.
- Design tension rods, connections and all affected bracing and foundation elements for overstrength forces  $Hov = 2.5 * Hy$  ( $2.0 * Hy$  for rings  $> 210$  diameter) but  $Hov < Hel / Ro$ .

## 7. Design Procedure for Systems with $T1 > 0.5$ (s) using Equal Displacement Principle

- Design the ring and bracing for non-seismic loading.
- Calculate the first period  $T1$  and system Stiffness  $K$ .
- Calculate the elastic seismic force  $Hel$  based on the applicable design code.
- Assume  $Rd = 5$ .
- Calculate the seismic design force  $Hf = Hel / (Rd * Ro)$ .
- Calculate the corresponding diagonal force  $Zf$ .
- Design the ring as described in Section 4.
- Check  $T1$  and  $K$  based on the chosen ring size.
- $K$  must be larger than  $Kmin = Hel / \delta max$ .
- If  $T1$  is higher than initially calculated, the designer can elect to refine the design or not.

Design the tension rods, connections and all affected bracing and foundation elements for overstrength forces  $Hov = 2.5 * Hy$  ( $2.0 * Hy$  for rings > 210 diameter) but  $Hov < Hel / Ro$ .

**8. Installation**

It is very important to install the ring exactly at the theoretical diagonal intersection point. A test performed on one braced frame with a ring 100 mm off-centre showed degradation of the hysteresis loops and pinching behaviour. Lock washers should be used. Slight pre-tensioning of the diagonal rods from the snug tight position is recommended. If higher capacity or stiffness is needed, wider rings with multiple diagonal rods as shown in Fig. 8 can be used.

**Ring Factored Tension Resistance -  $Z_r$**

Non Seismic loading  $Z_r = 0.9 * Z_y$

Seismic loading  $Z_r = Z_y$

$Z_y$  = Yielding capacity

$F_y$  (Mpa) = 350

$B$  (mm) = 100 (Ring Width)

$Do$  (mm) = 219

$t_r$  (mm) = 22

$A$  (mm) = 50

$C$  (mm) =  $(Do - T)/2 - A/2 + 5 = 78.5$

$Z_r = 1/6 * F_y * B * t_r^2 / 0.3 / C$

**$Z_r$  (kN) = 119.8868**      Seismic Loading

**$0.9Z_r$ (kN) = 107.8981**      Non - Seismic Loading

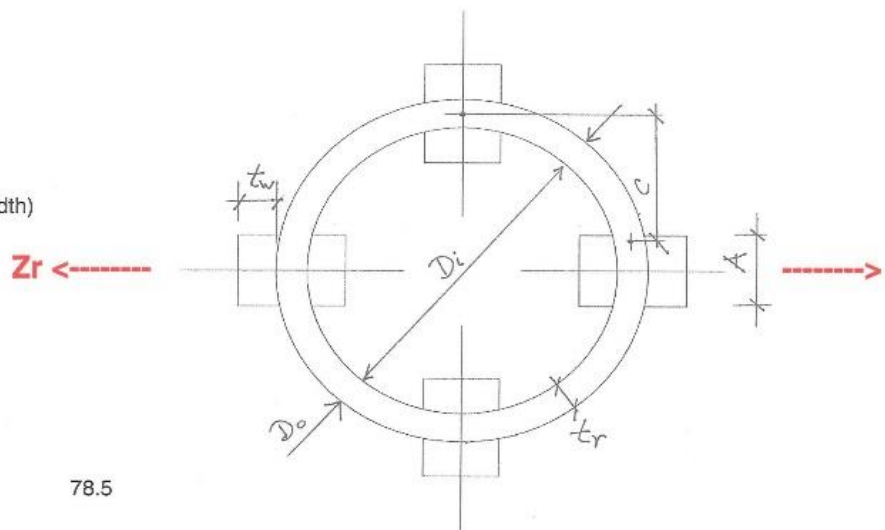

**Fig. 6.** Ring capacity example.

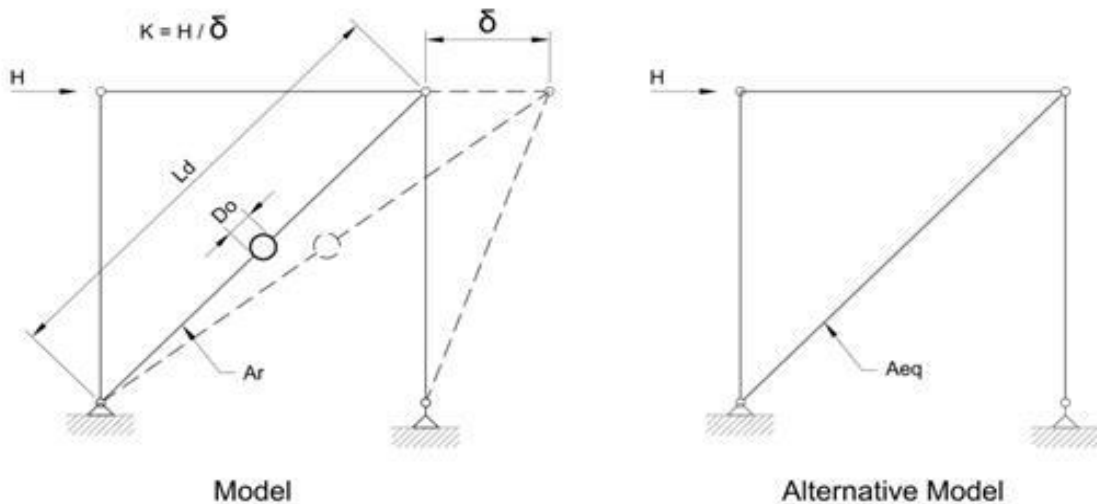

**Fig. 7.** Bracing stiffness models.

**Table 2.** Ring stiffness table.

Ring	$Do$ (mm)	$tr$ (mm)	$B$ (mm)	$Kr$ (kN/mm)
168/9.5	168	9.5	100	20
168/13	168	12.7	100	50
219/13	219	12.7	100	24
219/22	219	22	100	120
273/13	273	12.7	100	12
273/25	273	25.4	100	95
324/13	324	12.7	100	6.8
324/25	324	25.4	100	55

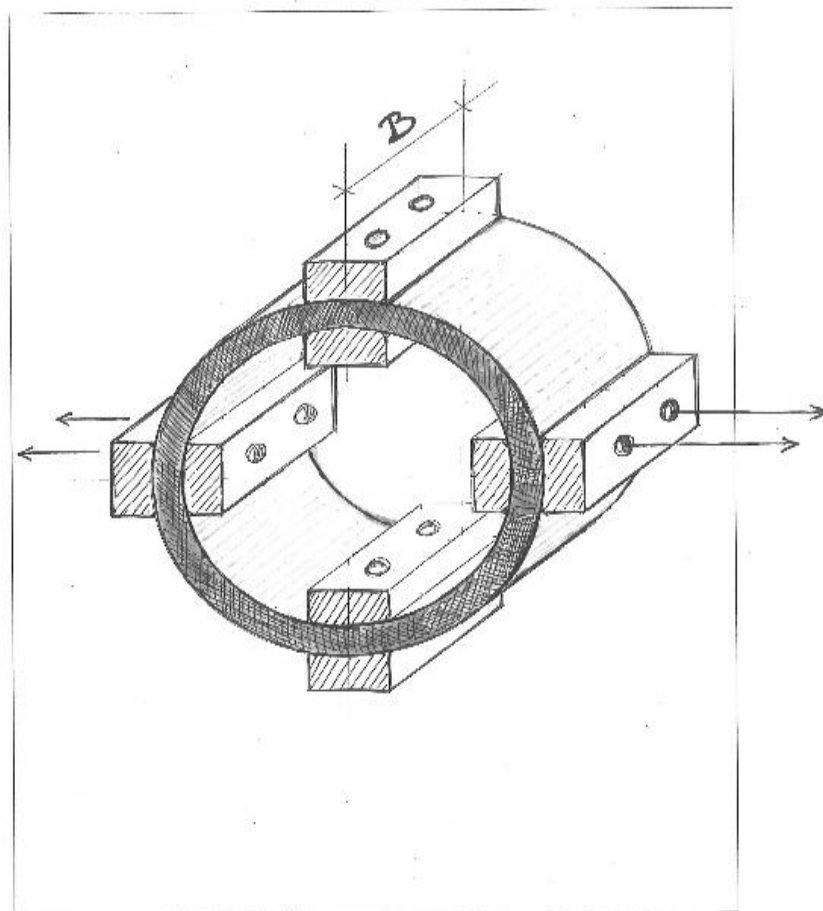
**Fig. 8.** Ring with multiple rods.



Rd - for T1 < 0.5 [s]

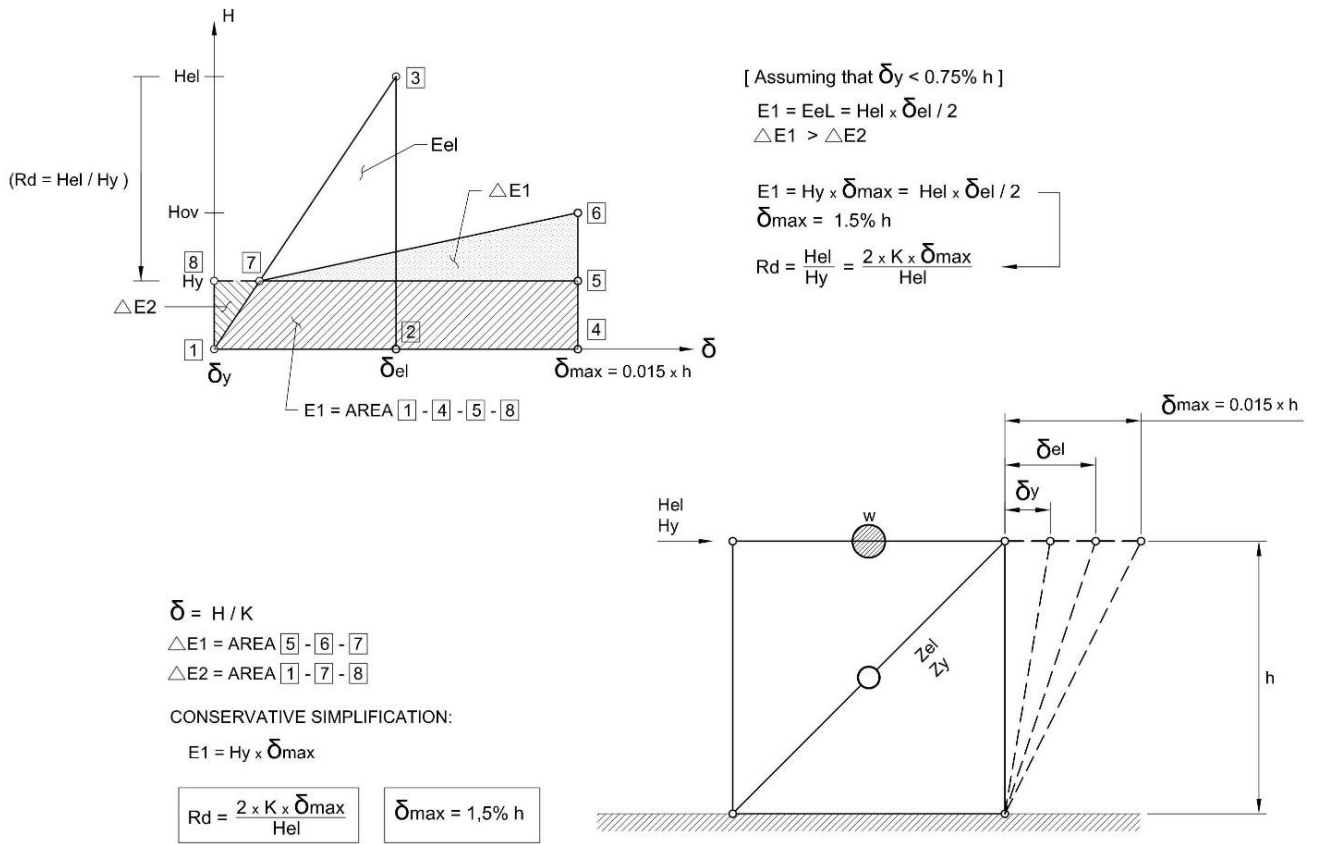

Fig. 9. Energy and drift diagrams.

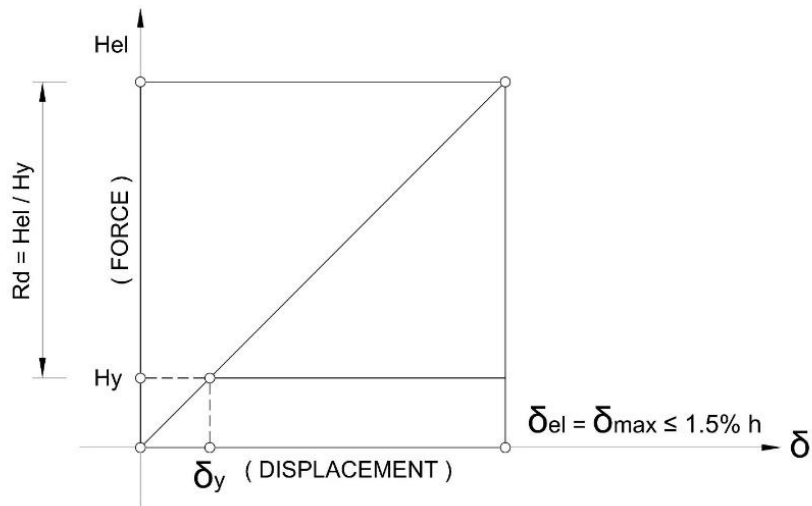

Fig. 10. Equal displacement principle diagram.

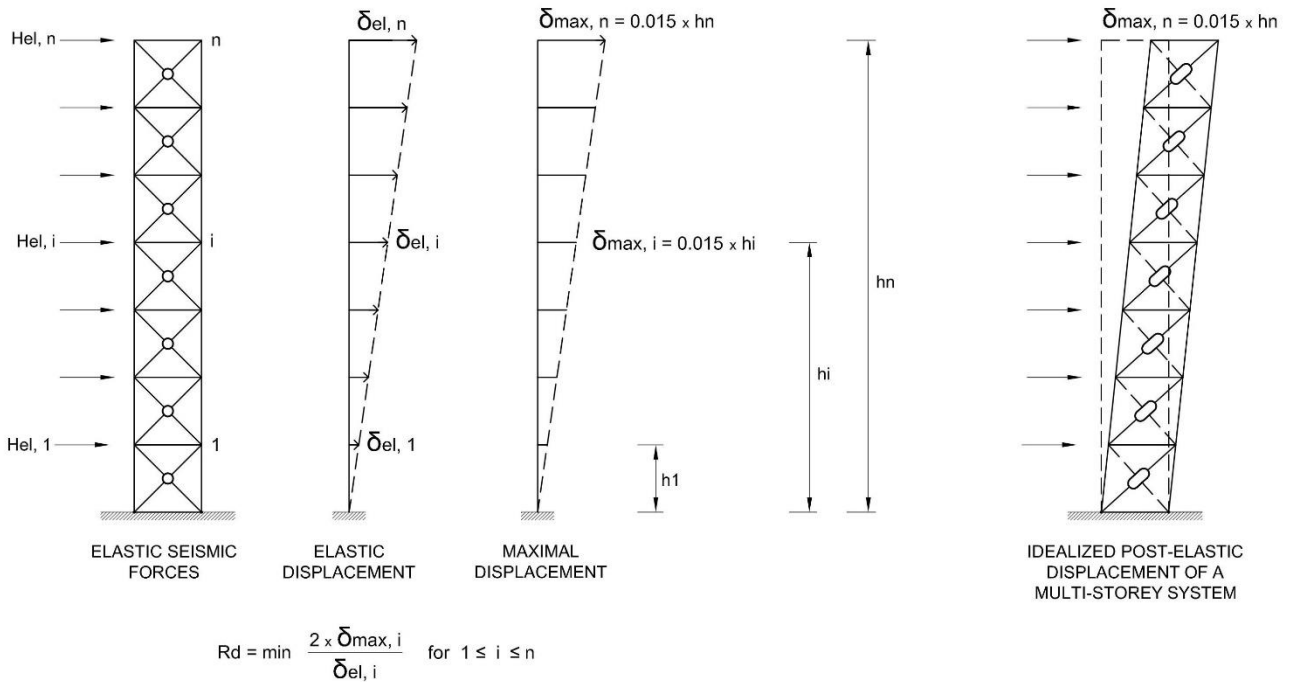

Fig. 11. Multi-storey systems.

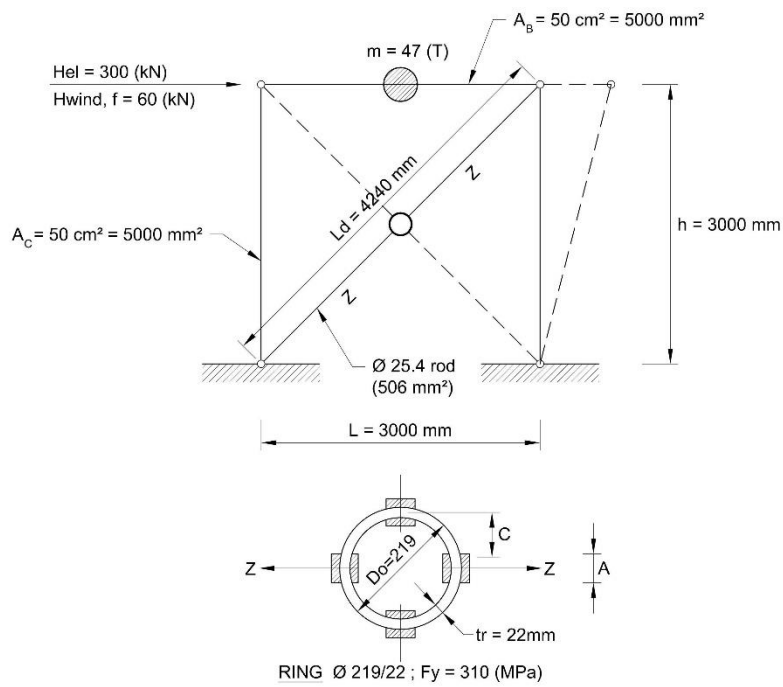

Fig. 12. Design example.

9. Conclusions

The procedure described in this paper allows designers to use a simple and ductile tension-only bracing system. The conservative design methodology described can be refined when the results from multi-storey braced frame tests are available. Larger diameter rings performed better in shake-table testing and can accommodate drift ratios greater than 1.5%.

Appendix A.

- Design Example:
- Ring Size: 219/22
  - B = 100 mm
  - Fy = 310 MPa
  - A = 50 mm
  - Ar = 506 mm<sup>2</sup>

### Wind Load Design

Factored diagonal wind load:  $Zf_{wind} = 1.414 * 60 = 85 \text{ kN}$

Ring factored moment:  $Mf_{wind} = 0.3 * Zf_{wind} * C$

- $C = (219 - 22) / 2 - (50 / 2 + 5) = 78.5 \text{ mm}$
- $Mf_{wind} = 0.3 * 85 * 78.5 = 2002 \text{ kNm}$
- Ring Wind Load Capacity:
- $Mr_{wind} = 1/6 * 0.9 * 310 * 100 * 222 * 10^{-3} = 2250 \text{ kNm}$

$Mr_{wind} > Mf_{wind}$

or, using  $Zr$ :

- $Zr_{wind} = 1/6 * 0.9 * 310 * 100 * 222 / (0.3 * 78.5 * 1000) = 95.6 \text{ kN} > Zf = 85 \text{ kN}$
- Or, using  $Zr$  and Table T1:
- $Zr_{wind} = 310 / 350 * 0.9 * 120 \text{ kN} = 95.6 \text{ kN} > Zf = 85 \text{ kN}$  (OK)

### Seismic Design

- $R0 = 1.50$
- $Kr = 120 \text{ kN/mm} = 120000 \text{ N/mm}$  (from Table T2)
- Equivalent diagonal  $Aeq = Ar * ld / (Ar * E / Kr + ld - Do)$
- $Aeq = 506 * 4240 / (506 * 210000 / 120000 + 4240 - 219) = 437 \text{ mm}^2$

The bracing is modelled using  $Aeq$  and a stiffness,  $K = 10 \text{ kN/mm}$  is determined. For a mass  $m = 47 \text{ tonnes}$ , the first period  $T1 = 0.43 < 0.5 \text{ (s)}$ .

Based on the applicable code, the elastic seismic force,  $Hel = 300 \text{ kN}$  and  $Zel = 424 \text{ kN}$

- $\delta_{max} = 0.015 * 3000 = 45 \text{ mm}$
- $Rd = 2 * K * \delta_{max} / Hel = 2 * 10 * 45 / 300 = 3.0$
- Seismic design force,  $Hf = Hel / (Rd * Ro) = 300 / (3 * 1.5) = 67 \text{ kN}$
- Seismic design diagonal force,  $Zf = 1.414 * 67 = 95 \text{ kN}$
- Ring capacity for seismic loading:
- $Mr = My = 1/6 * Fy * B * T^2$  and  $Zr = Zy = Mr / (0.3 * C)$
- $Hy = 0.707 * Zy$
- $Mr = 1/6 * 310 * 100 * 222 * 10^{-3} = 2500.67 \text{ kNm}$
- $Zr = Zy = 2500.67 / (0.3 * 78.5) = 106 \text{ kN} > Zf = 95 \text{ kN}$  (OK)

Ring Selected: 219/22

- $Hy = 0.707 * Zy = 0.707 * 106 = 75 \text{ kN}$
- Overstrength seismic force for design of the diagonal rods, columns and footings:
- $Hov = 2.0 * Hy < Hel / 1.50$
- $Hov = 2.0 * 75 = 150 \text{ kN} < 300 / 1.5 = 200 \text{ kN}$

### REFERENCES

- CSA S16-14 (2014). Design of Steel Structures. CSA Group, Mississauga, Canada.
- Djuric M (1973). Stabilnost i Dinamika Konstrukcija. Beogradski Univerzitet, Serbia.
- National Building Code of Canada (2010). National Research Council of Canada, Ottawa, Canada.
- Ventura CE, Motamedi M, Erdevicki D, Samoru S (2013). Tension-Only brace system for earthquake resistance of low rise buildings. EERF report for Steel Structure Education Foundation.