

## DESIGN AND STUDY ON THE EDGE CURVE OF BLADE OF A HANDHELD TILLER'S ROTARY BLADE

### 微耕机用旋耕弯刀刃口曲线设计及研究

Ms. Stud. Eng. Li S.T.<sup>1)</sup>, As. Eng. Yang L.<sup>1)</sup>, Ph.D. Eng. Niu P.<sup>1)</sup>, Ms. Stud. Eng. Zhang Y.H.<sup>1)</sup>,  
Prof. Eng. Xie S.Y.<sup>1)</sup>, Prof. Eng. Chen X.B.<sup>2)</sup>, Prof. Eng. Yang M.J.<sup>\*\*1)</sup>

<sup>1)</sup> Southwest University, College of Engineering and Technology / P. R. China;

<sup>2)</sup> Agricultural Machinery Quality Control and Inspection Technology Centre,  
Nanjing Research Institute for Agricultural Mechanization Ministry of Agriculture / P. R. China  
Tel: 8613883002509; E-mail: chxibi@126.com; ymingjin@swu.edu.cn

**Keywords:** rotary blade, edge curve, design parameters, mathematical model, CAD system, handheld tiller

#### ABSTRACT

The shapes and parameters of the edge curve of a rotary blade have important influence on the slip cutting performance, soil cutting resistance and soil throwing performance of the rotavators of a handheld tiller. In this study, taking the handheld tiller's rotary blade as a case study, the mathematical model of the edge curve of the rotary blade was built, and the CAD system of the rotary blade was obtained by means of the secondary development of AutoCAD based on Visual BASIC. Three rotary blades with different diameters and different edge curves were designed through the CAD system, the relative error of system output and calculated values (Excel) of parameters were studied, and the variation of grass removing angle of edge curve, scoop angle and tilling width were analyzed as well. The results showed that: the relative error of the system output and calculated values are at the level of 0.5%; the grass removing angle and scoop angle of edge curve edge are in the preferred value range; with cornerite increase, the grass removing angle and scoop angle linearly increase at large; on conditions of other parameters being constant, the tilling width decreases with increase of alpha angle.

#### 摘要

旋耕弯刀刃口曲线形状和对微耕机刀辊的滑切性能、切土阻力和抛土性能等具有重要影响。本文以圆盘式湿地弯刀为例，建立了微耕机用旋耕弯刀刃口曲线的数学模型，通过基于 Visual Basic 的 AutoCAD 二次开发，得到了旋耕弯刀的 CAD 系统。通过该 CAD 系统，设计了 3 把具有不同直径和不同形状刃口曲线的旋耕弯刀，研究了其参数输出值和计算值(Excel)的相对误差，分析了刃口曲线滑切角、背角和工作幅宽的变化规律。结果表明：系统输出值和计算值的相对误差均在 0.5% 水平，刃口曲线滑切角和刃口背角在较佳取值范围；滑切角和背角随着包角的增大而增大，呈近似线性关系；在其他条件不变的情况下，工作幅宽随着阿尔法角的增大而减小。

#### INTRODUCTION

The arable land of China that locates in the hills, mountains and plateaus region accounts for 69.3%, and the arable land located in the plains and basins accounts for only 30.7% (Hao, et al, 2003). Currently, handheld tillers are mainly used in the arable land in the hilly and mountainous areas. The functions of soil cutting, pulverization, soil turning, soil throwing and soil levelling, etc., and function that pushes the tillers forward by the soil reacting force from the soil-tilling are all achieved by the interaction of rotavator and soil while soil-tilling. The rotavator consists of some rotary blades and a shaft, and the geometric parameters of the blade directly affect the performance of a rotavator and the corresponding handheld tiller (Niu, et al, 2015). The shape of rotary blade edge including lengthwise edge and sidelong edge is decided by curve equation, maximum cornerite of the lengthwise edge curve, sidelong edge apex cornerite, bending angle and bending radius. And it has a significant impact on the grass removing angle and scoop angle, etc., thereby it affects the performance of grass removing of rotary blade, cut soil resistance and throwing soil properties.

At present, many scholars made some extensive investigations on the edge curve of blade of a handheld tiller's rotary blade, but they mainly focused on the performance of a single parameter or parameters of the experimental optimization. Hao et al studied the grass removing angle of lengthwise

edge, and found that the optimal values of the angle were in the range of  $35\text{--}55^\circ$  (Hao, et al, 2014); Gai et al studied the bending angle of sidelong edge, and found that the best values of the angle should be in the range of  $115\text{--}125^\circ$  (Gai et al, 2011); Sakai et al. experimentally studied the effects of scoop angle on soil cutting process, and obtained the reasonable range of scoop angle of the rotary blade under different soil conditions (Sakai et al, 1984); Saimbhi et al analyzed the force between the rotary blade and soil, and optimized the geometric parameters of edge curve of the blade (Saimbhi et al, 2004). However, the systematic research on the edge curve of rotary blade is not enough. For example, the principles to determine each parameter and the relationship between the various parameters are not quite clear. Standard GB / T5669-2008 (China) only provides curve equation and some parameters of common rotary blade, and it is difficult to define the sidelong edge curve as it is a space curve. Furthermore, there is no standard for the edge curve design of a handheld tiller's rotary blade, and reference is only given to the edge curve of blade of common rotary blade.

In this study, taking the handheld tiller's rotary blade as a case study, with reference to the standard GB / T5669-2008 (China) and JIS B 9210-1988 (2008 confirmed) (Japan), the mathematical model of the edge curve of a handheld tiller's rotary blade was established according to the geometric relations between each parameter, and the CAD system of rotary blade was obtained by means of the secondary development of AutoCAD based on Visual BASIC. The variation of grass removing angle, scoop angle and tilling width of rotary blade curve with different diameters and different shapes were studied as well. As a result, the study can provide references to the design, force and vibration reduction, and performance optimization for a handheld tiller's rotary blade.

## MATERIAL AND METHOD

### Material

The rotary blade, adaptable for wetland sticky paddy field tillage, is shown in fig.1. It was designed according to Chinese National Standard GB/T 5669-2008 "Rotary tiller-rotary blades and blade holders", Chongqing Standard DB50/T 277-2008 "Blades of micro-cultivator", and Japanese National Standard JIS B 9210-1988 (2008 confirmed) "Blades for tillers". The main design contents of a rotary blade include curve equation, maximum cornerite of the lengthwise edge curve, cornerite of sidelong edge apex, bending angle, bending radius, tilling width, grass removing angle and scoop angle etc.

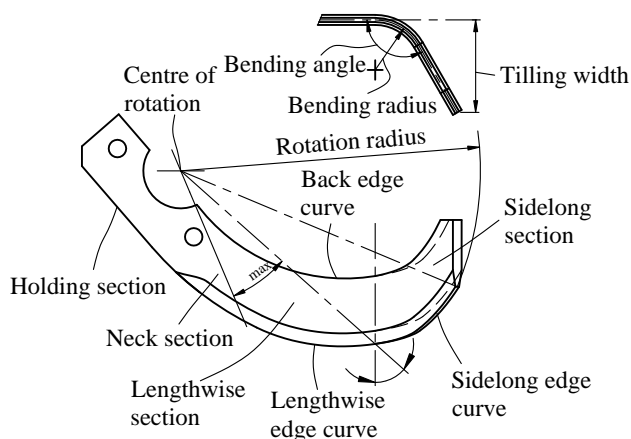

Fig. 1 - Structure and composition of the rotary blade

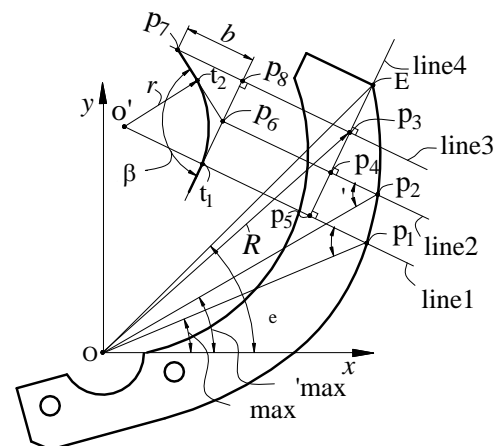

Fig. 2 - Developed view of the rotary blade in plane containing lengthwise edge curve

To simplify the modelling of the blade curve, the sidelong edge of the rotary blade was unfolded along the plane of lengthwise edge, and the coordinate system was defined as well, as shown in fig.2. Where:

- '<sub>max</sub> is the cornerite of bending point;
- <sub>max</sub> - maximum cornerite of the lengthwise edge curve;
- ' - angle between rotary radius of bending point with bending line;
- angle between rotary radius of end point of the lengthwise edge curve;
- E - apex of sidelong edge;

$\epsilon$  - cornerite of the apex of sidelong edge;  
 $r$  - bending radius;  
 $\alpha$  - bending angle;  
 $b$  - tilling width;  
 line 1- line 4 are auxiliary lines;  
 $p_1$ -  $p_8$  are points of intersection;  
 $t_1$  and  $t_2$  are points of tangency.

The edge curve is a spiral of Archimedes when it has been unfolded, and its equation is as follows:

$$R_n = a_0R + a_1R_n \quad (1)$$

where:

$R_n$  is rotation radius at a selected point on the edge curve, [mm];  
 $R$  – rotation radius of a rotary blade, [mm];  
 $\alpha$  – cornerite of the edge curve, [degree];  
 $a_0$  and  $a_1$  – constants.

Taking three rotary blades with different diameters and different edge curves as a case study, the construction process of the mathematical models and CAD system of the rotary blade was illustrated, and the parameters of the rotary blades were shown in table 1. The grass removing angle, scoop angle and tilling width, etc., of the blades were analyzed subsequently.

Table 1

Parameters of 3 rotary blades

Rotary blade	$R$ [mm]	$a_0$	$a_1$	$\alpha$ [°]	$R$ [mm]	$\alpha_{ma}$ [°]	$\alpha$ [°]	$e_0$ [mm]	$c_0$ [mm]	$l_0$ [mm]
1	180	0.58	0.0128	120	30	27	50	4	2	8
2	200	0.56	0.011	120	30	27	50	4.5	2	8
3	225	0.50	0.008	120	30	27	50	6	2	8

**Method**

**The mathematical models of edge curve**

The edge curve of rotary blade includes lengthwise edge and sidelong edge. The sidelong section takes the main responsibility for the soil-cutting (Yue, 2008). The lengthwise section is not only closely related to the performance of slip-cutting of the rotary blade, but also has a significant impact on the grass removing performance.

The design parameters of lengthwise edge curve include maximum cornerite of the lengthwise edge curve  $\alpha_{max}$ , the angle between rotary radius of end point of the lengthwise edge curve with bending line (namely the alpha angle for simplification), and grass removing angle  $\alpha$ .

Line 1 is the bending line of sidelong edge, line 2 is the bending midline, and line 1 is parallel to line 2. Point  $p_1$  is the end of sidelong edge, and it corresponds to the maximum cornerite of the lengthwise edge curve  $\alpha_{max}$ , as shown in fig. 2. Angles of  $\alpha_{max}$  and  $\alpha$  can be calculated as follows:

$$\left( \frac{k_2x_2 - y_2}{k_2 - \tan \alpha_{max}} \right)^2 + \left( \frac{k_2x_2 - y_2}{k_2 - \tan \alpha_{max}} \tan \alpha_{max} \right)^2 = (a_0R + a_1R_{\alpha_{max}})^2 \quad (2)$$

$$= \alpha_{max} + \alpha \quad [\text{degree}] \quad (3)$$

where:

$(x_2, y_2)$  is the coordinate of the bending point  $p_2$ ,

$$x_2 = (a_0R + a_1R_{\alpha_{max}}) \cos \alpha_{max}, \quad [\text{mm}];$$

$$y_2 = (a_0R + a_1R_{\alpha_{max}}) \sin \alpha_{max}, \quad [\text{mm}];$$

$k_2$  – the slope of line 2;

$$k_2 = \tan(180 - \alpha_{max} + \alpha).$$

The grass removing angle of a point is defined as the angle between velocity vector and normal plane, as shown in fig.3. Apply the derivative to equation of lengthwise edge curve, and the grassing moving angle can be expressed as:

$$= \arctan \left( \lim_{\rightarrow 0} \frac{R(+ ) \cos(+ ) - R(- ) \cos(- )}{R(+ ) \sin(+ ) - R(- ) \sin(- )} \right) - , [\text{degree}] \quad (4)$$

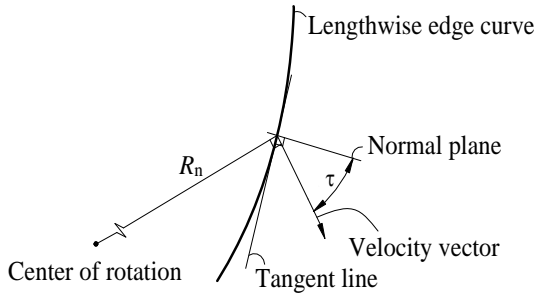

Fig. 3 - Definition of grass removing angle

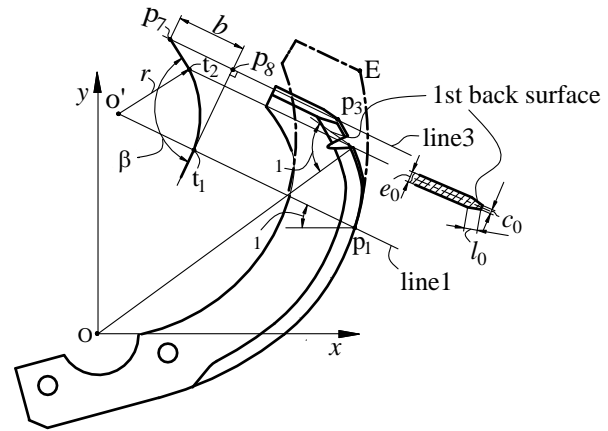

Fig. 4 - The schematic diagram of scoop angle

The design parameters of sidelong edge curve include cornerite of the apex of sidelong edge  $E$ , the bending radius  $r$ , the bending angle  $\beta$ , scoop angle  $\alpha_1$ , and the tilling width  $b$ . where,  $r$  is generally set as 30 mm, and  $\beta$  is generally set as  $120^\circ$ .

Since the length of the edge curve keeps constant before and after the bending deformation, there is:

$$A - (A - t_1 t_2) \cos(180 - S) - r \sin S = B \quad (5)$$

where:

$A$  – the distance between  $E$  and  $p_5$ , and :  $A = t_1 p_7$ , [mm];

$B$  – the distance between  $E$  and  $p_3$ , [mm].

When the end point of lengthwise edge  $P_1$  is known, dimensions of  $A$  and  $B$  contain only one unknown parameter  $E$ , thus  $E$  can be obtained by equation (5).

Similarly, the tilling width  $b$  can be expressed as:

$$b = (A - t_1 t_2) \sin S + (r - r \cos(180 - S)), [\text{mm}] \quad (6)$$

According to literature (Zhang Y., Yang L., et al., 2016), the scoop angle has the following expression:

$$\alpha_1 = \arctan \left( \frac{(e_0 - c_0) \cos \alpha_1}{2 \cos \left( -\frac{\alpha_1}{2} \right) \sqrt{l_0^2 - \frac{(e_0 - c_0)^2}{4}}} \right) + \arctan \frac{y}{x} + \alpha_1, [\text{degree}] \quad (7)$$

where:

$e_0$  is the blade thickness, [mm];

$c_0$  – edge width, [mm];

$l_0$  – edge surface width, [mm];

$\alpha_1$  – the angle of plane conversion, [degree], and it is generally set as  $60^\circ$ ;

$(x, y)$  – the coordinate of a point after the sidelong edge is bended, [mm];

$\alpha_1$  – the angle between bending line and x-axis, [degree], as shown in fig.4.

### The CAD system of edge curve

The relevant design parameters of the rotary blade curve can be calculated in accordance with mathematical models. However, since some design parameters are interrelated and the mathematical

models of some parameters are complex, lots of iterations are required to define the parameters. The CAD system of the edge curve is an important part of CAD system of the rotary blade. By developing the CAD system of edge curve, the design calculations can be greatly simplified, and the design efficiency can be greatly improved. The CAD system of the edge curve consists of subsystems of computing and graphics, and the program flow of the CAD system is shown in fig.5. The computing subsystem performs the calculation function of design parameters and the graphics subsystem performs the drawing function of blade curve designed.

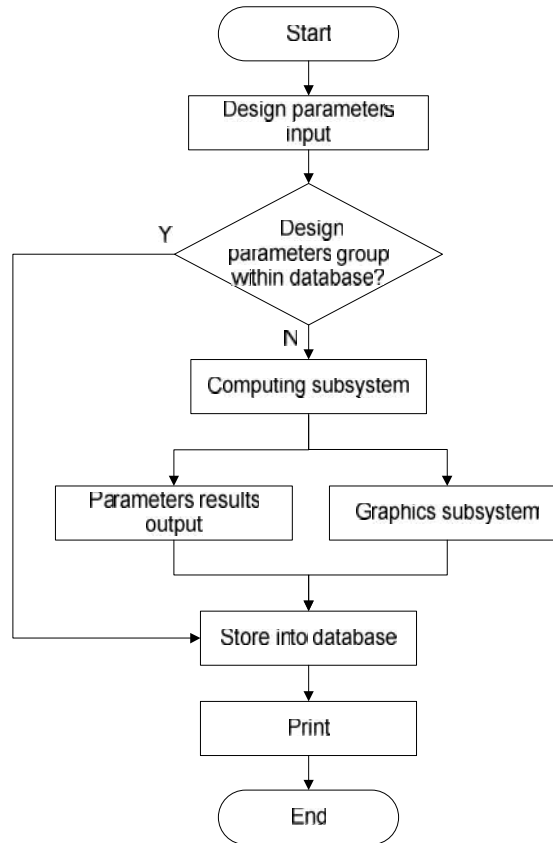

Fig. 5 - The program flow of CAD system

## RESULTS

### Interface of the CAD system

The main interface of the CAD system of edge curve of the rotary blade is shown in fig.6. Click the Parameters input button, and this will open a panel for parameters input; Close the Parameters input panel by clicking the Close button after parameters input; then click the Compute button in the main interface, and the design parameters of the edge curve that meet the design requirements will be obtained; then click the Print Button, and this will open a panel for displaying outline of the edge curve of a rotary blade, as shown in fig.7.

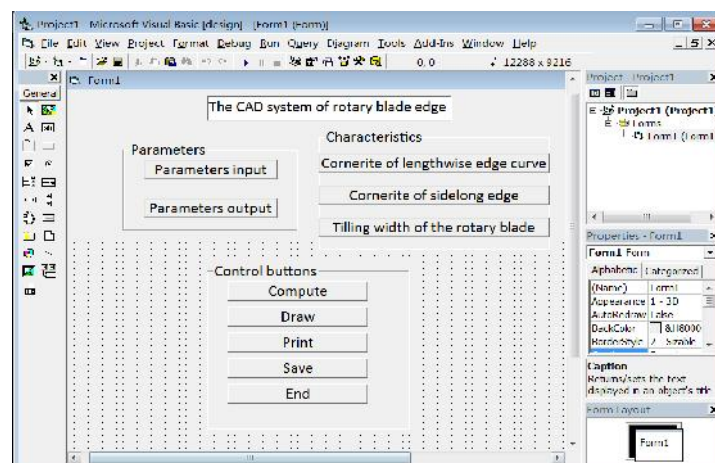

Fig. 6 – Main interface of the CAD system

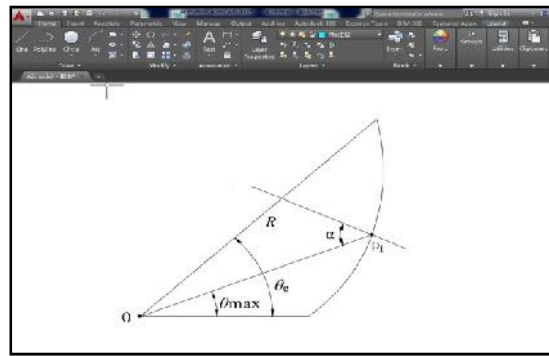

Fig. 7 – Interface of edge curve print

### Accuracy verification of the CAD system

There are 2 ways in which we can obtain the final design parameters, namely by means of Excel calculation and CAD system. The former is obtained through direct calculation based equations of mathematical models of edge curve, and it needs much calculation and time for the calculation; the latter being obtained through iterations, accompanying by such errors as iterative error and approximation error, thus parameter values of CAD system output deviate from those calculated values. Take 3 main parameters of edge curve of the rotary blades, namely alpha angle  $\alpha$ , the cornerite of the apex of sidelong edge  $r_e$  and the tilling width  $b$ , for the accuracy verification, and the results of error analysis are shown in table 2.

Table 2

Error analysis

Rotary blade	Parameters	Results		
		Calculated (Excel)	Output (CAD system)	Relative error [%]
1	$\alpha$ [degree]	45.396	45.250	0.32
	$r_e$ [degree]	45.858	45.620	0.51
	$b$ [mm]	61.524	61.457	0.32
2	$\alpha$ [degree]	46.426	46.20	0.44
	$r_e$ [degree]	47.020	46.836	0.39
	$b$ [mm]	58.640	58.374	0.45
3	$\alpha$ [degree]	46.824	46.647	0.37
	$r_e$ [degree]	47.256	47.018	0.50
	$b$ [mm]	56.284	50.062	0.39

As can be seen from table 2, the relative error of the system output and calculated values is at the level of 0.5%, which confirms that the accuracy of CAD system is good and it meets the design requirements of a handheld tiller's rotary blade.

### Effects of parameters of edge curve on the performance of a rotary blade

By the CAD system of edge curve of the rotary blade, values of grass moving angle with different cornerite of lengthwise edge were obtained for the rotary blades with other parameters listed in table 1, as shown in fig.8. As can be seen from fig.8, for a preselected point on the edge curve with certain cornerite, the grassing moving angle of rotary blade 3 has the maximum value and those angles of rotary blade 2 and rotary blade 1 decrease sequentially. With the increase of cornerite of the lengthwise edge, the grass moving angle approximately increases linearly. The grass moving angle of the lengthwise edge for the rotary blades with parameters in table 1 ranges from 38.3 to 53.1°, and it is in the recommended range of 35- 55°, according to literature (Hao X., Li Z., et al., 2014). The grassing moving angle contributes much to the performance of slip cutting and grass removing performance, and the bigger of grassing moving angle, the better of the performance of slip cutting and grass removing.



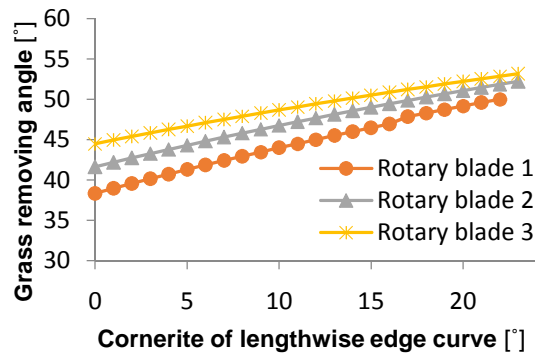

Fig. 8 - Grass removing angle of lengthwise edge curve

Similarly, values of scoop angle with different cornerite of sidelong edge were obtained by the CAD system for the rotary blades with other parameters listed in table 1, as shown in fig. 9. As can be seen from fig.9, for a preselected point on the edge curve with certain cornerite, the scoop angle of rotary blade 3 has the maximum value and those angles of rotary blade 2 and rotary blade 1 decrease sequentially. With the increase of cornerite of the sidelong edge, the scoop angle approximately increases linearly. The scoop angle of the sidelong edge for the rotary blades with parameters in table 1 ranges from 57.8 to 69.2° and it is in the recommended range of 55-75°, according to literature (Sakai J. et al., 1984). The rotary blade is suitable for tilling in loam and clay loam, and it is consistent with the application situation of soil type of wet and sticky soil for the rotary blades studied.

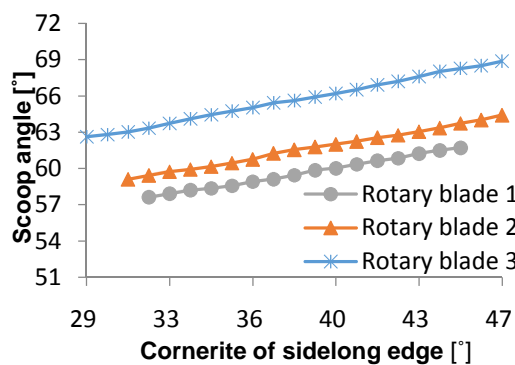

Fig. 9 - Scoop angle of sidelong edge curve

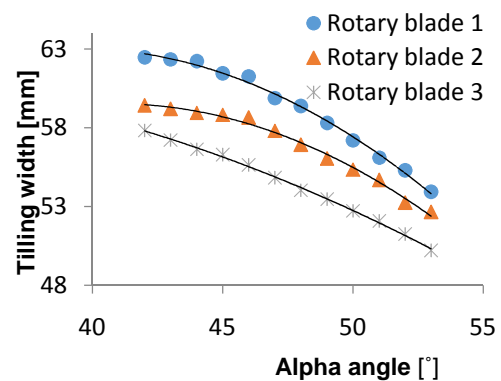

Fig. 10 - Tilling width of the rotary blade

Changing the alpha angle leads to the change of tilling width of a rotary blade, and this can be employed to obtain the required tilling width of the rotary blade. While keeping parameters of rotation radius of rotary blade, bending angle and bending radius, etc. constant, the values of tilling width of the rotary blades (listed in table 1) of different alpha angle were obtained by the CAD system, as shown in fig. 10. As can be seen from fig.10, with the increase of alpha angle, the tilling width decreases. According to the literature (Chinese Academy of Agricultural Mechanization Sciences, 2007), the number of rotary blade of rotavator and production costs can be reduced by increasing tilling width. Nevertheless, tilling width that exceeds the suitable values will seriously affect the stiffness of rotary blade and pulverization, therefore the actual application requirements need to be considered while determining the tilling width.

## CONCLUSIONS

(1) Based on mathematical model of edge curve, a CAD system of edge curve of the rotary blade was developed in this study. The relative error of the system output and calculated values is at the level of 0.5%, and it can meet the design requirements of a handheld tiller's rotary blade.

(2) With increase of cornerite of the lengthwise edge, the grass moving angle approximately increases linearly. And the grass moving angle of lengthwise edge for the rotary blades with parameters in table 1 ranges from 38.3 to 53.1°, which indicates good performance of slip cutting and grass removing of the rotary blade.

(3) With increase of cornerite of the sidelong edge, the scoop angle approximately increases linearly. The scoop angle of sidelong edge for the rotary blades with parameters in table 1 ranges from 57.8 to 69.2°, which is consistent with the application situation of soil type of wet and sticky soil for the rotary blades studied.

(4) With increase of alpha angle, the tilling width of the rotary blades decreases. While keeping parameters of rotation radius of rotary blade, bending angle and bending radius, etc. constant, the required tilling width could be obtained by adjusting the alpha angle.

## ACKNOWLEDGEMENT

The study was funded by Chongqing Science & Technology Commission (cstc2016shmszx80037), Ph.D. Research Project of Southwest University (SWU115011), and Fund from Key Laboratory of Modern Agricultural Equipment, Ministry of Agriculture, Republic of China (201601001).

## REFERENCES

- [1] Ding W., Peng S., et al., (1995), Study on the grassing moving of rotary blade and equation (旋耕刀滑切角及滑切角方程的研究), *Transactions of the Chinese Society of Agricultural Engineering*, issue 4, pp.67-72;
- [2] Gai C., Dong Y., et al., (2011), Optimization of bending angle of rotary machine rotary tilling blade based on COSMOS (基于 COSMOS 的还田机械旋耕刀弯折角优化), *Journal of Agricultural Mechanization Research*, issue 3, pp.30-33;
- [3] Hao F., Chang Y., et al., (2003), Farmland resource faced with challenge and its countermeasures for sustainable utilization in China (中国土地资源面临的挑战与可持续对策), *Nature Ecological conservation*, issue 4, pp.30-33;
- [4] Hao X., Li Z., et al., (2014), Optimum design and experiment about parameters of rotary blade and rotavator (微耕机旋耕刀片及其刀辊的参数的优化设计与实验), *Farm Machinery*, issue 5, pp.155-158;
- [5] Jun S., Hai L., Koichi L., et al. (1984), Tillage resistance characteristics of Japanese rotary blades—distribution of tilling resistance to the tipless (straight) blade and bending tip portion of a rotary blade, *Journal of the Japanese Society of Agricultural Machinery*, vol.46, issue 1, pp.593-598;
- [6] Niu P., Yang L., Zhang Y., Gao B., Li Y., Yang M., (2015), Finite element analysis of the rotary blade of a mini-tiller based on ANSYS Workbench (基于 ANSYS Workbench 的微耕机用旋耕弯刀有限元分析), *Journal of Southwest University (Natural Science Edition)*, vol.37, Issue 12, pp.162-147;
- [7] Peng B., Yang L., Yang M., Guo M., Ye J. Chen J., (2014), On connotation analysis and development countermeasures of the mini-tiller stand system (微耕机标准体系内涵分析及其发展对策), *Journal of Southwest Normal University (Natural Science Edition)*, vol.39, issue 4, pp.141-146;
- [8] Saimbhi V., Wadhwa D., Grewal P.,(2004) , Development of a rotary tiller blade using three. - dimensional computer graphics, *Biosystems Engineering*, vol.89, issue 1, pp.47-58;
- [9] Sakai J., Lam Van H., Iwasaki K., Shibata Y., (1984), Tillage resistance characteristics of Japanese rotary blades— distribution of tilling resistance to the tipless (straight) blade and bending tip portion of a rotary blade (ロータリ耕なたづめの耕うん抵抗特性-直刃部とわん曲部へのトルク分配), *Journal of the Japanese Society of Agricultural Machinery*, vol. 46, issue 1, pp. 593-598;
- [10] Yue G., (2008), An elementary analysis to blade of a handheld tiller's rotary blade (微耕机配套用旋耕刀浅析), *Farm Machinery*, vol.1, issue 7, pp.50-51;
- [11] Zhang Y., Yang L., et al., (2016), Study on the sloop angle characteristics of a handheld tiller's rotary blade (微耕机用旋耕弯刀正切刃背角特性研究), *INMATEH Agricultural Engineering Journal*, vol.49, issue 2, pp.5-12;
- [12] \*\*\*Ministry of Industry and Information Technology of the P. R. China, (2013), Handheld tillers JB/ T 10266-2013 (微型耕耘机 JB/ T 10266-2013), China Machine Press, P. R. China;
- [13] \*\*\*Chinese Standard Committee, (2008), Rotary tiller - rotary blades and blade holders, GB/T 5669-2008 (旋耕机械刀和刀座, GB/T 5669-2008), Chinese Standard Press, P. R. China;
- [14] \*\*\*Chinese Academy of Agricultural Mechanization Sciences, (2007), *Agricultural Machinery Design Manua*, (农业机械设计手册), China Agricultural Science and Technology Press, P.R. China;
- [15] \*\*\*Chongqing Bureau of Quality and Technology Supervision, (2008), Blades of micro-cultivator, DB50/T 277-2008 (微耕机配套用旋耕刀, DB50/T 277-2008), Chongqing, P. R. China;
- [16] \*\*\*Japanese Industrial Standards Committee, (2008), Blades for tillers, JIS B 9210-1988(2008 confirmed)(耕うんづめ, JIS B 9210-1988 (2008 確認)), Japanese Standards Association, Japan.