

THEORETICAL STUDIES ON THE WORKING CAPACITY OF DISK DEVICES FOR GRINDING AGRICULTURAL CROP SEEDS

/

ТЕОРЕТИЧНІ ДОСЛІДЖЕННЯ ПРОДУКТИВНОСТІ ДИСКОВОГО ТЕРКОВОГО ПРИСТРОЮ ДЛЯ ВИТИРАННЯ НАСІННЯ СІЛЬСЬКОГОСПОДАРСЬКИХ КУЛЬТУР

Assist. Tverdokhlib I.V., Ph.D. Spirin A.V.

Vinnitsa National Agrarian University

Tel: +380672152088; E-mail: igor_tverdokhlib@yahoo.com

Keywords: legume grasses, technological process, disc grating apparatus

ABSTRACT

The article describes the technological process of operation of the improved disc grating apparatus aimed to grate seed of legume grasses and presents the results of analytical studies of its performance.

РЕЗЮМЕ

У статті наведено опис технологічного процесу роботи удосконаленого дискового теркового пристрою, призначеного для витирання насіння бобових трав і результати аналітичних досліджень продуктивності його роботи

INTRODUCTION

Sustainable development of agricultural production in Ukraine is possible on the basis of further modern mechanization of all production processes through the development and introduction of highly efficient technologies of crop harvesting, including perennial legume grasses (Grynyk I. et al, 2014).

Sharp decrease of livestock population in Ukraine in recent years has led to the decline of such industry as seed production of perennial legume grasses (clover, alfalfa, sweet clover). Researches on the development of technologies and means of mechanization that would improve quality indicators of machines aimed to harvest seed of perennial legume grasses practically have not been carried out in recent years. Recently there has been observed a trend towards the intensification of production of animal products, so there is a need to develop feed base of farms and to provide these farms with seed of such crops as perennial legume grasses (clover, alfalfa, sweet clover) (Burkov A. et al, 2008).

Operational process of treatment or wiping of alfalfa seed from a pile that is threshed by the working bodies of harvesting machines and then goes to the separating transporting and technological systems is one of the most important and complex technological operations in the scope of the technological process of operation of combine harvesters. Growth of the degree of seed wiping, reduction of seed damage and losses are priority goals in terms of meeting agricultural and technical requirements for seed processing, i.e. seed quality (Adamchuk V. and Bulgakov V., 2010).

The problem of improvement of the technological level of grating modules, which are assessed by the seed quality indicators remains particularly relevant in terms of further development of stationary threshing machines and combine harvesters in general.

There is a great variety of construction and layout schemes of the stationary threshing machines and working bodies of grating devices. This is related to both harvesting technologies and agro-technical requirements for quality indicators of grating legume grass seed (Antipin V. and Erk F., 2006; Burkov A., et al, 2008). Since the development and application of the first technical devices and facilities for mechanical harvesting of legume grasses an extensive experience in the establishment of relevant working bodies and machines has been gained in the world practice. Agro-biological and mechanical properties of the grass seeds have a great influence on working conditions of grating modules and regulate construction features of working bodies for grating off legume grass seed (Grynyk I. et al, 2014).

Taking into account specific mechanical and technological properties of seed inside the pod and world tendencies of harvesting legume grasses it can be concluded that the technological process of grass seed grating should be performed by the working bodies of stationary machines according to the principle of seed grating off from the pods (Burkov A. et al, 2008)

Therefore, improvement of construction and layout schemes and working bodies of machines for grating legume grass seed and substantiation of parameters of their working bodies should be carried out taking into account specific properties of this process. This is particularly important and actual to provide necessary quality indicators of work according to agro-technical requirements (Antipin V. and Erk F., 2006).

The objective of the study is to increase technological process indicators of harvesting of legume grasses through the development and substantiation of working parameters of the discs grating device.

MATERIAL AND METHOD

In general, the object of research of the discs grating device (DGD) is a technological process of treatment (wiping) of the prepared material (pile of alfalfa). The integral component of the technological process of lucerne pile treatment is the study of changes of the technological parameters or changes of DGD performance depending on the construction and technological parameters of its structural elements. The subject of research is construction and kinematic parameters of the working bodies of DGD that perform technological process of seed removal from alfalfa pile, and performance parameters.

Methodology of the theoretical research was based on the mathematical modelling of the technological process of DGD operation in order to construct determinate mathematical models that characterize basic technological parameters.

Development of modern advanced layout schemes and new constructions of working bodies of the threshing-separating devices and their modules must be based on the international experience, taking into account peculiarities of local agricultural, technical, economic, and environmental requirements.

Based on the analysis of the obtained quality indicators and technological indicators of harvesting legume grasses we have proposed an improved design of DGD ДТП (Tverdokhlib I. and Anelyak M., 2013; Tverdokhlib I. et al, 2014)

Construction scheme of DGD is shown in Fig.1.

Grinding disc device DGD includes the body 6, where the tank is set 1, which has a loading mouth feed 2 and loading opening 3. In the tank space pin activator is installed 4, which has boards 5. Activator is fixed on top of the shaft 9, and on the lower part of the shaft moving grinding disc is fixed 8. In the body it is set a fixed disk 7, which has a glass, the hole of which follows loading mouth feed. Glass is designed as a hollow cylinder on the outside of which the threaded bushing is twirled. To the bottom surface of fixed disk are the beaters, installed on the disk in the form of rays. Beaters are made from steel in the reef form which has a notch. In the intervals between beaters concentric to the axis of the disc are placed ring lugs. At the bottom of tank there is the output channel 10.

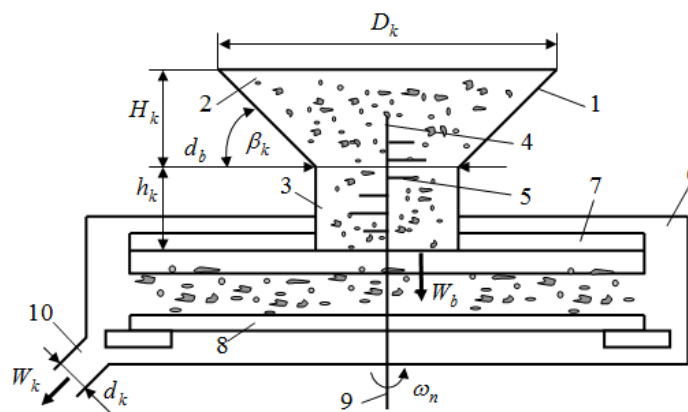

Fig.1 – Constructional scheme DGD:

1 – tank; 2 – loading mouth feed; 3 loading hollow; 4 – activator; 5 – blade; 6 – body;
7, 8 – stationary and moving disc; 9 – driving shaft; 10 – output channel

RESULTS

In addition to the ability to grind seeds, grinding device is also characterized by operational and technological criteria, including technological capacity. (Antipin V., Erk F., 2006) regulates the productivity of grinding devices and, ultimately, productivity of harvesting machines, or the ability to handle pile constituents without their 'download' on working surfaces for minimizing damage and loss of seeds.

To sustain the rational constructive-kinematic parameters DGD that meet the technical data of the machine, first is theoretical foundation of DGD band width or performance (Tverdokhlib I., Spirin A. 2015)..

The basis of the criterion foundation process work DGD is that the capacity of its working bodies within interval $t = 1$ C, or productivity must be equal or higher than the total of per second filing alfalfa pile that comes to them from previous transport and technological systems of harvesting machines, so the condition shall be fulfilled:

$$dQ_n / dt \geq dW_b / dt, \text{ or } Q_n \geq W_b, \quad (1)$$

where: Q_n – capacity (or productivity) accident DGD, kg/s;

W_b – general pile loading seconds transferred to DGD, kg/s.

In order to formalize alfalfa pile processing by DGD and to further study of the parameters of its working bodies, let's consider the design scheme of the internal working space surround channel, shown in Fig.2 and workflow of DGD.

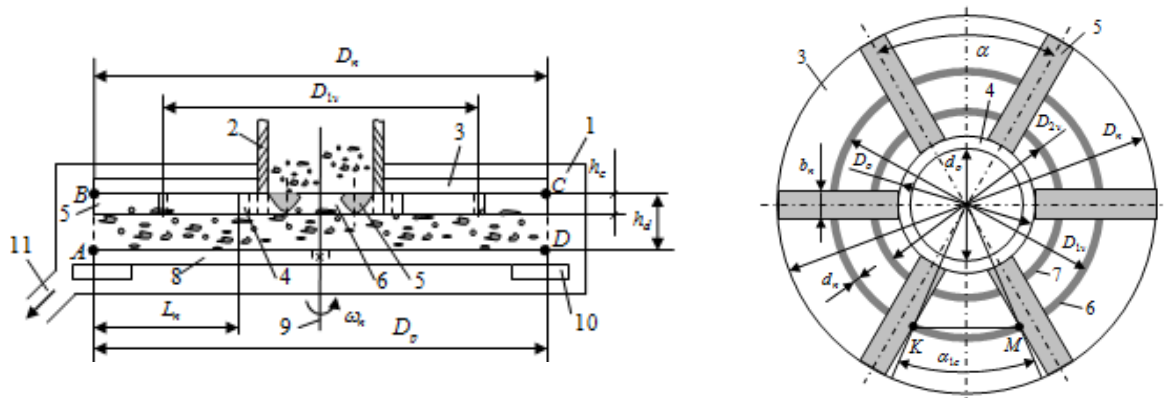

Fig.2 – Design scheme of the internal working space surround channel of DGD

1 – body; 2 – bushing; 3, 8 – stationary and moving disc; 4 – clip; 5 – beater; 6, 7 – ring lugs; 9 – shaft; 10 – blade; 11 – output channel

The internal volume of the working space of DGD is formed by adjacent - vertical position of stationary 3 (Fig.2) and 8 movable discs placed in the body 1 with the clearance, the height of which is h_d , with the outer diameter of the disk D_n and moving D_p that installed on the shaft 9 rotating with angular speed ω_n . In worktop of the stationary disk perpendicular and concentric to it is fixed holder 4, made in the form of bushings, outer diameter of which is D_o as mid - d_o and are installed in form of rays- beaters 5 the number of which is k_n , made in the form of rays (reefs) with the width b_n , length L_n and height h_c , which are enshrined to the hub. There are also on the working surface of the stationary disk in between beaters concentric to the axis of the disk ring lugs 6, 7 of total number k_v , formed as a round rod; the average diameter is from the centre of the disk at a distance of $0.5 D_{1v}$ and $0.5 D_{2v}$.

For further analysis and description of the formalized process of wiping alfalfa seeds in the context of the scheme we accept the following assumptions:

- the working space is a rectangle ABCD in section, that is why the working surfaces of the stationary 3 and the movable disks 8 are parallel to each other, so $D_n = D_p$;

- the cross section of beaters 5, which is fixed to the radial inner surface of the stationary disk is a segment of a cylinder with equal height segment h_c ;

- diameter ring lugs 6, 7 which are concentric to the axis stationary disk and is the same d_n as the height of the sleeve 4 is cross-sectional height of 5 and beaters totals h_c .

Pile with non - grind alfalfa seeds enters through the loading channel 2 the internal volume space of the working channel of an DGD, where the centrifugal force shifts it from the centre axis of the movable disk 8 and from the axis centre of rotation of disc 3 fixed to their periphery. In the process of its motion in space working channel the process of grinding alfalfa seeds takes place, and further processed alfalfa pile is taken by blades 10 which direct it to the output channel 11, through which it leaves GDD.

Productivity of DGD, Q_n , according to (Bronstein I. and Semendyaev K., 2009; Gorbert Goldeteyn et al, 2012) can be calculated by a common formula which determines the performance of machines of continuous action.

$$Q_n = F_p \rho_v \varphi_n V_c; F_p = 0,25\pi(D^2 - d_v^2); \varphi_n = V_v / V_n; V_n = 0,25\pi D^2 h_d \quad (2)$$

where:

F_p – the working area of basic (moving) disk, m²;

ρ_v – Bulk alfalfa pile density, kg/m³;

φ_n – Filling factor of internal working space formed by figure *ABCD*;

V_c – the average speed of the processed pile towards the periphery of the disc, m/s;

V_v – the amount of space pile alfalfa working channel, m³;

V_n – The total amount of space inside the working channel, m³;

V_n – Diameter and height of the cylinder, m.

The maximum possible volume $V_{v,max}$ of alfalfa pile that fills the space of the working channel of an DGD will consist of the difference of the total internal volume V_n of the working space of the channel and the total volume $\sum V_e$ of structural elements that are installed on the inner surface of the fixed disk and which hold a certain amount volume, i.e.

$$V_{v,max} = V_n - \sum V_e = V_n - \left(V_w + \sum_{j=1}^{k_n} V_{b_j} + \sum_{i=1}^{k_v} V_{k_i} + V_d \right) \quad (3)$$

where:

V_w , $\sum_{j=1}^{k_n} V_{b_j}$, $\sum_{i=1}^{k_v} V_{k_i}$, V_d – accordingly, bushings volume, the total volume of the beaters ring inserts and drive shaft volume, m³.

This amounts corresponding figures that adopted the design elements found on the inner surface of the real disk are determined by formulas

$$V_w = 0,25\pi h_c (D_o^2 - d_o^2); \sum_{j=1}^{k_n} V_{b_j} = F_c L_n k_n = 0,5 r_b^2 [(\pi \alpha_b / 180) - \sin \alpha_b] L_n k_n \quad (4)$$

$$\sum_{i=1}^{k_v} V_{k_i} = \sum V_{1v} + \sum V_{2v} + \dots + \sum V_{iv}; V_d = 0,25\pi d_v^2 h_d; i = 1, 2, \dots, k_v \quad (5)$$

$$\sum_{i=1}^{k_v} V_{k_i} = (V_1 + V_2 + \dots + V_i) - V'_{k_n} k_n k_v \quad (6)$$

where:

D_o , d_o – outer and inner diameter of bushing, m;

h_c – height of bushings, m;

F_c – beaters cross-sectional area or segment, m²;

α_b – central angle, tightening beater chord, grade;

k_n – total number of installed beaters, pcs.;

L_n , r_b – beat length and radius of the arc segment beat, m;

$\sum V_{1v}$, $\sum V_{2v}$, ..., $\sum V_{iv}$ – the total volume of one of the ring insert, which is placed concentrically at a distance from the centre of the stationary disc is equal, respectively, to $0,5 D_{1v}$, $0,5 D_{2v}$, ..., $0,5 D_{iv}$, m³;

V_1 , V_2 , ..., V_i – respectively, the total volume of each i of ring insert, which is placed concentrically at a distance from the centre of the stationary disc is equal, respectively, to $0,5 D_{1v}$, $0,5 D_{2v}$, ..., $0,5 D_{iv}$, m³;

V'_{k_n} – the amount of each i ring insert, which is placed across the width b_n of each set on a fixed disk beater, m^3 .

On the other hand the difference between the constituent right side of equation (6) can be written in the form $V_1 - V'_{1k_n} = V_{1k_n}$, $V_2 - V'_{2k_n} = V_{2k_n}$, $V_i - V'_{ik_n} = V_{ik_n}$, where V_{1k_n} , V_{2k_n} , ..., V_{ik_n} – the amount of each i ring insert, which is placed between two adjacent concentric beaters away from the centre of the real disk is equal, respectively, to $0.5 D_{1v}$, $0.5 D_{2v}$, ..., $0.5 D_{iv}$, m^3 .

Then the total volume of each i ring insert which is placed concentrically at a distance from the centre of the real disk, which is equal to, respectively, $0.5 D_{1v}$, $0.5 D_{2v}$, ..., $0.5 D_{iv}$ will be determined by the formula:

$$\sum V_{1v} = V_{1k_n} k_n; \sum V_{2v} = V_{2k_n} k_n; \sum V_{iv} = V_{ik_n} k_n, \text{ a } V_1 = 0,25\pi^2 D_{1v} d_n^2; V_2 = 0,25\pi^2 D_{2v} d_n^2; V_i = 0,25\pi^2 D_{iv} d_n^2 \quad (7)$$

where: D_{1v} , D_{2v} , ..., D_{iv} – the diameter of the centre section of the centre ring of the torus, m;

d_n – diameter of circular section torus, m.

Volume of each sector i ring insert, which is placed between two adjacent concentric beaters away from the centre of the stationary disk is equal to, respectively, $0.5 D_{1v}$, $0.5 D_{2v}$, ..., $0.5 D_{iv}$ and angle between the central part of i torus with (7) will be determined by the formula

$$\left. \begin{aligned} V_{1k_n} &= 0,25\pi^2 D_{1v} d_n^2 \alpha_{1c} / 360^0; \\ V_{2k_n} &= 0,25\pi^2 D_{2v} d_n^2 \alpha_{2c} / 360^0; \\ &\dots\dots\dots; \\ V_{ik_n} &= 0,25\pi^2 D_{iv} d_n^2 \alpha_{ic} / 360^0 \end{aligned} \right\} \quad (8)$$

where: α_{1c} , α_{2c} , ..., α_{ic} – central angle that tights a chord of each sectorial i ring insert, which is placed at a distance from the centre of stationary disk at $0.5 D_{1v}$, $0.5 D_{2v}$, ..., $0.5 D_{iv}$, rad.

Central angle that tights a chord of each sectorial share of i ring insert, which is placed at a distance from the centre of the disc real is equal, respectively, to $0.5 D_{1v}$, $0.5 D_{2v}$, ..., $0.5 D_{iv}$ according to (Grynyk *I. et al*, 2014) and is given by formula:

$$\alpha_{1c} = 2 \arcsin(a_{1v} / D_{1v}); \alpha_{2c} = 2 \arcsin(a_{2v} / D_{2v}); \alpha_{ic} = 2 \arcsin(a_{iv} / D_{iv}) \quad (9)$$

where: a_{1v} , a_{2v} , ..., a_{iv} – a chord length of each sectorial share of i ring insert, which is placed between two adjacent concentric beaters away from the centre of the real disk is equal, respectively, to $0.5 D_{1v}$, $0.5 D_{2v}$, ..., $0.5 D_{iv}$, charged by corresponding central angle, α_{1c} , α_{2c} , ..., α_{ic} , m.

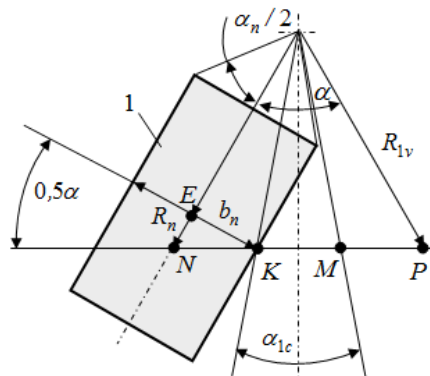

Fig. 3 – Scheme to determine the length of the chord:
1 - beater

To determine the length of the chord a_{1v} , a_{2v} , ..., a_{iv} , consider the composite scheme (Fig.3), while:

$$a_{KM} = 2(R_{1v} + 0,5b_n / \sin(\alpha/2)) - 2 \cdot 0,5b_n / \cos(\alpha/2) = D_{1v} + \frac{b_n}{2} \left(\frac{1}{\sin(\alpha/2)} - \frac{1}{\cos(\alpha/2)} \right) = a_{1v} \quad (10)$$

$$a_{2v} = D_{2v} + \frac{b_n}{2} \left(\frac{1}{\sin(\alpha/2)} - \frac{1}{\cos(\alpha/2)} \right); \quad a_{iv} = D_{iv} + \frac{b_n}{2} \left(\frac{1}{\sin(\alpha/2)} - \frac{1}{\cos(\alpha/2)} \right) \quad (11)$$

Then, according to (9) and (10) we have

$$\left. \begin{aligned} \alpha_{1c} &= 2 \arcsin \left(1 + \frac{b_n}{2D_{1v}} \left(\frac{1}{\sin(\pi/k_n)} - \frac{1}{\cos(\pi/k_n)} \right) \right); \\ \alpha_{2c} &= 2 \arcsin \left(1 + \frac{b_n}{2D_{2v}} \left(\frac{1}{\sin(\pi/k_n)} - \frac{1}{\cos(\pi/k_n)} \right) \right); \\ &\dots\dots\dots; \\ \alpha_{ic} &= 2 \arcsin \left(1 + \frac{b_n}{2D_{iv}} \left(\frac{1}{\sin(\pi/k_n)} - \frac{1}{\cos(\pi/k_n)} \right) \right) \end{aligned} \right\} \quad (12)$$

Then, substituting the values (12) to (9), and subsequently (9) (8) and according to (7), we obtain the formula for determining the total volume of each *i* ring insert, which is placed between two adjacent beaters and between beater central angle $\alpha_{1c}, \alpha_{2c}, \dots, \alpha_{ic}$, a sector of a torus of *i*.

$$\left. \begin{aligned} \sum V_{1v} &= 0,5\pi^2 D_{1v} d_n^2 k_n \arcsin \left(1 + \frac{b_n}{2D_{1v}} \left(\frac{1}{\sin(\pi/k_n)} - \frac{1}{\cos(\pi/k_n)} \right) \right) / 360^0; \\ \sum V_{2v} &= 0,5\pi^2 D_{2v} d_n^2 k_n \arcsin \left(1 + \frac{b_n}{2D_{2v}} \left(\frac{1}{\sin(\pi/k_n)} - \frac{1}{\cos(\pi/k_n)} \right) \right) / 360^0; \\ &\dots\dots\dots; \\ \sum V_{iv} &= 0,5\pi^2 D_{iv} d_n^2 k_n \arcsin \left(1 + \frac{b_n}{2D_{iv}} \left(\frac{1}{\sin(\pi/k_n)} - \frac{1}{\cos(\pi/k_n)} \right) \right) / 360^0 \end{aligned} \right\} \quad (13)$$

where:

$V_w, \sum V_b, \sum_{i=1}^{k_v} V_{k_i}, V_d$ – bushings volume, the total volume of the beater inserts and ring volume drive shaft m^3 .

Substituting the value of the total volume of each of *i* ring inserts with (13) in the first equation (5) we obtain the formula for determining the total beater volume k_n the total of which occupies the space of the working channel of DGD:

$$\sum_{i=1}^{k_v} V_{k_i} = \frac{0,5\pi^2 d_n^2 k_n}{360^0} \left\{ \begin{aligned} &D_{1v} \arcsin \left[1 + \frac{b_n}{2D_{1v}} \left(\frac{1}{\sin(\pi/k_n)} - \frac{1}{\cos(\pi/k_n)} \right) \right] + \\ &+ D_{2v} \arcsin \left[1 + \frac{b_n}{2D_{2v}} \left(\frac{1}{\sin(\pi/k_n)} - \frac{1}{\cos(\pi/k_n)} \right) \right] + \dots + \\ &+ D_{iv} \arcsin \left[1 + \frac{b_n}{2D_{iv}} \left(\frac{1}{\sin(\pi/k_n)} - \frac{1}{\cos(\pi/k_n)} \right) \right] \end{aligned} \right\} \quad (14)$$

The total volume $\sum V_e$ of structural elements that take a certain amount of the total internal volume V_n of the working space bed according to (3), (4) and (14) will be determined by the formula:

$$\sum V_e = 0,25\pi h_c (D_o^2 - d_o^2) + 0,5r_b^2 [(\pi\alpha_b / 180) - \sin\alpha_b] L_n k_n + 0,25\pi d_v^2 h_d + \left. \begin{aligned} &+ \frac{0,5\pi^2 d_n^2 k_n}{360^0} \left[D_{1v} \arcsin \left[1 + \frac{b_n}{2D_{1v}} \left(\frac{1}{\sin(\pi/k_n)} - \frac{1}{\cos(\pi/k_n)} \right) \right] + \right. \\ &+ D_{2v} \arcsin \left[1 + \frac{b_n}{2D_{2v}} \left(\frac{1}{\sin(\pi/k_n)} - \frac{1}{\cos(\pi/k_n)} \right) \right] + \dots + \\ &\left. + D_{iv} \arcsin \left[1 + \frac{b_n}{2D_{iv}} \left(\frac{1}{\sin(\pi/k_n)} - \frac{1}{\cos(\pi/k_n)} \right) \right] \right] \end{aligned} \right\} \quad (15)$$

At maximum volume $V_{v.max}$ alfalfa pile that fills the space of the working channel of the DGD according to (3)–(5) and (14) is determined:

$$V_{v.max} = 0,25\pi D^2 h_d - 0,25\pi h_c (D_o^2 - d_o^2) + 0,5r_b^2 [(\pi\alpha_b / 180) - \sin\alpha_b] L_n k_n + \left. \begin{aligned} &+ \frac{0,5\pi^2 d_n^2 k_n}{360^0} \left[D_{1v} \arcsin \left[1 + \frac{b_n}{2D_{1v}} \left(\frac{1}{\sin(\pi/k_n)} - \frac{1}{\cos(\pi/k_n)} \right) \right] + \right. \\ &+ D_{2v} \arcsin \left[1 + \frac{b_n}{2D_{2v}} \left(\frac{1}{\sin(\pi/k_n)} - \frac{1}{\cos(\pi/k_n)} \right) \right] + \dots + \\ &\left. + D_{iv} \arcsin \left[1 + \frac{b_n}{2D_{iv}} \left(\frac{1}{\sin(\pi/k_n)} - \frac{1}{\cos(\pi/k_n)} \right) \right] \right] \end{aligned} \right\} + \quad (16)$$

$$+ 0,25\pi d_v^2 h_d$$

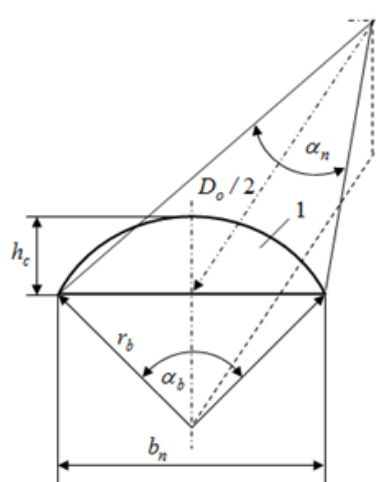

Fig. 4 – Scheme for definition of central angle α_b and radius r_b :
1 – beater

To determine the central angle α_b , tightening chord b_n of beater 1 and radius r_b we consider the composite circuit shown in Fig. 4.

According to Fig.4 and identities that are given in [6] we have $b_n = 2\sqrt{2h_c r_b - h_c^2} = 2r_b \sin(\alpha_b / 2)$, or $b_n^2 = 4(2h_c r_b - h_c^2)$, $\sin(\alpha / 2) = b_n / 2r_b$.

Where:

$$r_b = (b_n^2 / 8h_c) + 0,5h_c; \quad \alpha_b = 2 \arcsin \left(\frac{b_n h_c}{0,125b_n^2 + h_c^2} \right) \quad (17)$$

Maximum coefficient of filling $\varphi_{n.max}$ the internal space of the working channel of the DGD according to (2), (3) and (16), (17) is determined:

$$\begin{aligned}
& h_c (D_o^2 - d_o^2) + \frac{4}{\pi} [(b_n^2 / 8h_c) + 0,5h_c]^2 \times \\
& \times \left[(\pi \arcsin(b_n h_c / 180) \cdot (0,125b_n^2 + h_c)) - \sin \frac{b_n h_c}{0,125b_n^2 + h_c} \right] L_n k_n + d_v^2 h_d + \\
& + \frac{\pi d_n^2 k_n}{180} \left\{ D_{1v} \arcsin \left[1 + \frac{b_n}{2D_{1v}} \left(\frac{1}{\sin(\pi / k_n)} - \frac{1}{\cos(\pi / k_n)} \right) \right] + \right. \\
& + D_{2v} \arcsin \left[1 + \frac{b_n}{2D_{2v}} \left(\frac{1}{\sin(\pi / k_n)} - \frac{1}{\cos(\pi / k_n)} \right) \right] + \dots + \\
& \left. + D_{iv} \arcsin \left[1 + \frac{b_n}{2D_{iv}} \left(\frac{1}{\sin(\pi / k_n)} - \frac{1}{\cos(\pi / k_n)} \right) \right] \right\} \\
\varphi_{n,max} = 1 - \frac{\quad}{D^2 h_d} \quad (18)
\end{aligned}$$

The average speed V_c of pile processed towards the periphery of the movable and immovable discs will be determined:

$$V_c = V_m \lambda_v = 0,5(d\varphi / dt) D \lambda_v = 0,5\omega_n D \lambda_v, \quad (19)$$

where:

V_m – the theoretical speed of the material, m/s;

λ_v – factor for the decline rate V_m relative to the theoretical average speed V_c ;

φ – rolling disk angle, grad.;

ω_n – angular velocity of a moving disk, rad/s.

Thus, maximum productivity of DGD $Q_{n,max}$ according to (2), (18) and (19) is determined by dependence:

$$Q_{n,max} = \pi \omega_n \lambda_v \rho_v (D^2 - d_v^2) \left(1 - \frac{h_c (D_o^2 - d_o^2) + (4\Theta L_n k_n / \pi) + d_v^2 h_d + \Omega \pi d_n^2 k_n / 180}{8D h_d} \right) \quad (20)$$

Where:

$$\Theta = [(b_n^2 / 8h_c) + 0,5h_c]^2 \times \left[(\pi \arcsin(b_n h_c / 180) \cdot (0,125b_n^2 + h_c)) - \sin \frac{b_n h_c}{0,125b_n^2 + h_c} \right]$$

$$\begin{aligned}
\Omega = & D_{1v} \arcsin \left[1 + \frac{b_n}{2D_{1v}} \left(\frac{1}{\sin(\pi / k_n)} - \frac{1}{\cos(\pi / k_n)} \right) \right] + \\
& + D_{2v} \arcsin \left[1 + \frac{b_n}{2D_{2v}} \left(\frac{1}{\sin(\pi / k_n)} - \frac{1}{\cos(\pi / k_n)} \right) \right] + \dots + \\
& + D_{iv} \arcsin \left[1 + \frac{b_n}{2D_{iv}} \left(\frac{1}{\sin(\pi / k_n)} - \frac{1}{\cos(\pi / k_n)} \right) \right]
\end{aligned}$$

For practical use of the dependence (20), which is cumbersome, based on further analysis will hold its simplification based on the following considerations.

Maximum meaning of filling factor $\varphi_{n,max}$ the space working channel of DGD can be represented as a product useful volume φ'_n and the working space entered factor φ_e for the volume that is occupied by the structural elements installed on the inner surface of the stationary disc. This meaning is defined as the ratio of the total amount $\sum V_e$ of structural elements that are installed on the inner surface of the stationary disk to the total internal volume V_n space of the working channel of DGD or:

$$\varphi_e = \sum V_v / V_n = \frac{h_c(D_o^2 - d_o^2) + 4\Theta L_n k_n / \pi + d_v^2 h_d + \frac{\pi d_n^2 k_n}{180^0} \Omega}{8Dh_d} \quad (21)$$

Then, taking into account the factor φ_e , the actual meanings of filling $\varphi_{n,max}$ the space of the working channel of the DGD will be determined:

$$\varphi_{n,max} = \varphi'_{n,max} \varphi_e = \left(\varphi'_{n,max} h_c(D_o^2 - d_o^2) + 4\Theta L_n k_n / \pi + d_v^2 h_d + \frac{\pi d_n^2 k_n}{180^0} \Omega \right) / 8Dh_d \quad (22)$$

In this case, the maximum productivity of DGD $Q_{n,max}$ according to (22) will be determined by dependence:

$$Q_{n,max} = 0,125\pi D(D^2 - d_v^2) \rho_v \varphi'_{n,max} \varphi_e \lambda_v \frac{d\varphi}{dt} =$$

$$= 0,125\pi D(D^2 - d_v^2) \rho_v \varphi'_{n,max} \lambda_v \frac{h_c(D_o^2 - d_o^2) + 4\Theta L_n k_n / \pi + d_v^2 h_d + \frac{\pi d_n^2 k_n}{180^0} \Omega}{8Dh_d} \frac{d\varphi}{dt} \quad (23)$$

Or:

$$Q_{n,max} = \frac{\pi^2 n_n D(D^2 - d_v^2) \rho_v \varphi'_{n,max} \varphi_e \lambda_v}{120}, \quad (24)$$

where: n_n – fixed speed rot/min.

The resultant dependence (24) characterizes the change in productivity of DGD depending on its structural and kinematic parameters.

According to the dependence (24) constructed are image reproductions $Q_{n,max}$ as functional changes: Fig. 5 – $Q_{n,max} = f(D, n)$, Fig. 6a – $Q_{n,max} = f(n)$; Fig. 6b – $Q_{n,max} = f(\varphi'_n)$.

Analysis of dependence $Q_n = f(D, n)$ (Fig. 5) shows that productivity of DGD varies approximately in the range of 0.2 to 1.3 kg/s, depending on the meaning of the diameter D and rotational speed n_n of moving disc by linear variation of Q_n , with increased productivity n_n and unit growing D , which is also characteristic for dependencies that are shown in Fig. 6.

Significant productivity growth Q_n is observed in the meaning of movable disk diameter of $D \geq 0.5$ m, with a range of changes $400 \leq n_n \leq 1000$ rot/min for the moving diameter of $D = 0.6$ m, drive productivity Q_n increases by about 0.65...0.7 kg/s (Fig. 6a) and a significant increase in productivity Q_n , depending on changes in fill factor φ'_n working space channel of GDD (about 0.2...0.25 kg/s) is the meaning of $\varphi'_n \geq 0.5$ (Fig. 6b).

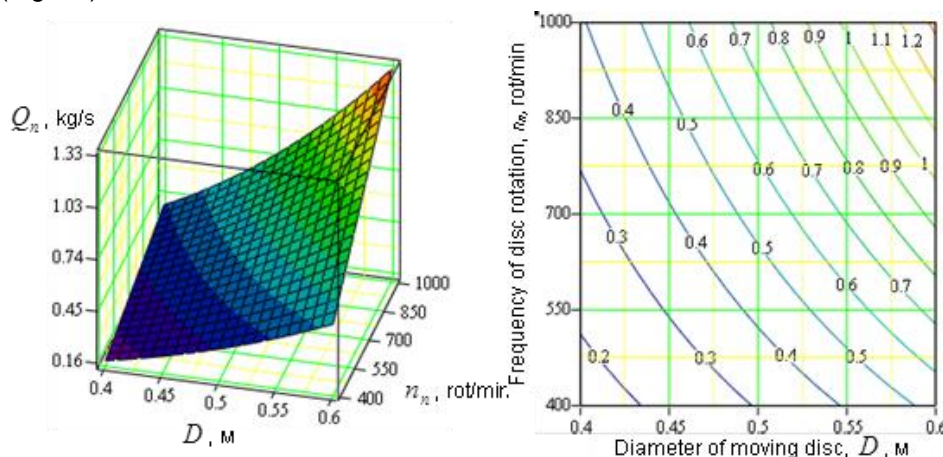

Fig.5 – Dependence of change Q_n as functional: $Q_{n,max} = f(D, n)$

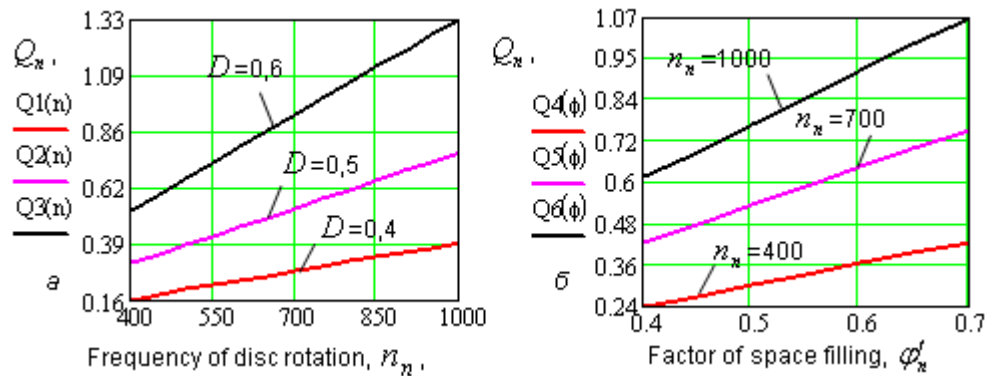

Fig.6 – Dependence of change Q_n as functional: $a - Q_{n,max} = f(n)$; $b - Q_{n,max} = f(\phi'_n)$

CONCLUSIONS

Thus, the developed analytical model of DGD productivity allows to theoretically support structural and kinematic parameters and modes of grinding device.

REFERENCES

- [1] Adamchuk, V., Bulgakov, V., (2010), The current state of scientific support of agricultural mechanization (Сучасний стан наукового забезпечення механізації сільського господарства), *Scientific Journal NUBiP Ukraine (Науковий вісник НУБіП України)*, pp.144;
- [2] Antipin V., Erk F., (2006), *Production of perennial grass seeds (Производство семян многолетних трав*, Rosselkhozizdat, p.191, Moscow/Russia;
- [3] Bronstein, I., Semendyaev K., (2009), *Mathematical Handbook (Справочник по математике)*, Ed. physical and mathematical literature, pp.608, Moscow/Russia;
- [4] Bugaev V., Kolesnik S., Anthony S., (2008), *Technology of growing perennial grasses for seed: recommendations (Технології вирощування багаторічних трав на насіння: рекомендації)*. Vinnitsa/Institute of feed UAAS, p.48, Ukraine;
- [5] Burkov A., Smirnov M., Mashkovtsev M., (2008), Definition of quality indicators of operation of the device for wiping grass seed (Определение показателей качества работы устройства для вытирания семян трав). *Mechanization and electrification of agriculture (Механизация и электрификация сельского хозяйства)*, Issue number 12, pp.18-19, Moscow/Russia;
- [6] Fedorenko V., Buklagin D., Kostina L., (2009), For the selection of machines, variety trials and initial seed field crops (Машины для селекции, сортоиспытания и первичного семеноводства полевых культур : каталог), *Katalog: FGBNU "Rosinformagroteh"*, pp.224, Moscow/Russia;
- [7] Gorbert Goldetejn, Charles Poole, Dzhon Safko, (2012), *Classical Mechanics (Классическая механика)*, Institute computer isledovany, p.367;
- [8] Grynyk I., Adamchuk V., Kaletnik G., Bulgakov, V., (2014), The state of design and production of agricultural machinery modern technical level in Ukraine (Стан проектування і виготовлення в Україні сільськогосподарських машин сучасного технічного рівня), *Mechanization and electrification of agriculture (Механізація і електрифікація сільського господарства)*, no.99 (1), pp.34-39;
- [9] Gukov Y., Grytsyshyn M., (2008), State of mechanization of agricultural production in Ukraine (Стан механізації сільськогосподарського виробництва в Україні), *Mechanization of agricultural production (Механізація сільськогосподарського виробництва)*, Vol.XIV, pp.64-70, Kyiv;
- [10] Tverdokhlib I., Anelyak M., Kuzmich A., Kustov S., (2013), *Threshing-separating device (Молотильно-сепаруючий пристрій)*, Patent № 101449, Ukraine;
- [11] Tverdokhlib I., Anelyak M., Kuzmich A., Kustov S., (2014), *Device for friction (Терковий пристрій)*, Patent № 105114, Ukraine;
- [12] Tverdokhlib I., Spirin A (2015), The results of experimental studies of seed wiping by disk-grinding device (Результати експериментальних досліджень витирання насіння дисково-терковим пристроєм), *Engineering, Energy, Transport, Agriculture (Техніка, енергетика, транспорт АПК)*, Vol.92 (3), pp.28-36, Vinnitsa/Ukraine.