

# A REVIEW ON MULTIFUNCTIONAL ROBOTIC VEHICLE FOR INDUSTRIAL AND SECURITY APPLICATIONS

<sup>1</sup>Prof. Bagwan M Faruk Sk Musa, <sup>1</sup>Prof.Raviprakash S. Shriwas, <sup>1</sup>Mr.Sumit G.Dhamodikar, <sup>1</sup>Ms.Sayali P. Gulhane, <sup>1</sup>Mr.Akshay D. Dikondawar, <sup>1</sup>Ms.Puja L. Alone

<sup>1</sup>Dept. of EXTC  
<sup>1</sup>J.D.I.E.T Yavatmal  
<sup>1</sup>Yavatmal, India.  
[mfbagwan@yahoo.com](mailto:mfbagwan@yahoo.com)

**Abstract**— In any industry or household work, the picking and placing are very basic operations and have been required to do it again and again .One way is the use of a small vehicle capable of doing pick and place type of work. The system proposed will include the robust assembly for these types of functions with the wireless operation and control using RF module. The system will have a wireless camera that will be used for continuous monitoring of the surrounding environment where the vehicle will be placed.

Another important aspect is the security of workplace for some natural hazards and also from thefts. The model will also include fire sensor and theft detection system with direct transmission of the signals to fire brigade and control and security office by using GSM module. It will also buzz the alarm at the same time of detection .Hence it will provide total security in the night time or when the workplace is off. The total functions will be built around AVR microcontroller with obstacle and metal detection also. Hence the vehicle will have total of five applications right from mechanical work, monitoring to the security and alarming.

**keywords**—RF module, GSM module, AVR microcontroller.

## INTRODUCTION

Life is the most priceless gift of the universe, which cannot be substituted or replaced. As generations have passed by, complexity of life has increased to such an extent that populaces are certainly not as concerned about the safety processes. In the present day scenario, fire accidents are on the rise due to sheer negligence and hence resulting in the loss of countless lives to which no effective procedures are being undertaken [1].

Robot is defined as a mechanical design that is capable of performing human tasks or behaving in a human-like manner. To built robot requires expert and complex programming [2]. Now a day's Robotics is part of today's communication & communication is part of advancement of technology, so we have decided to work on ROBOTICS to design something which will take human life to next era. ROBOT has sufficient intelligence to cover the maximum area within provided space. It is having an infrared sensor which are used to sense the obstacles coming in between the path of ROBOT [3].

Recent developments in the field of robotics and wireless communication have resulted in many widely adopted wireless standards, with each of the catering for different needs depending upon the utility of the user. We have also described here one of the applications of wireless communication by incorporating the wireless technology with a robotic vehicle which will be of optimum use in the workplace. This designing of a robotic system using RF technology with wireless camera, sensor and with an additional GSM feature. GSM based control systems implements the emerging applications of the GSM technology. GSM technology is also used to make the project more user friendly. The project helps to generate interests as well as innovations in the fields of robotics while working towards a practical and obtainable solution to save lives and mitigate the risk of property damage.

Technology makes use and knowledge of different tools, machines, along with techniques, systems and methods of organization for solving a problem as well as perform a specific function. It also refers for the collection of tools, machinery as well as procedures. Technology has affected society along with surroundings in a different ways. In society, technology is helping for development of more advanced economies and has allowed the rise of a leisure class. The implementation of this project is to resolve the problem of replacing a human work with wireless controlled omnidirectional monitoring robot with video support that fcompletely controlled with wireless network. The recent developments in technology which permit the use technology such as wireless, using wireless it have capabilities of communicating with each other. Wireless is a new technology, which has at its center the goal of eliminating wired connections between computers [4].

## OVERALL DESIGN OF THE SYSTEM

In this project the first type of robot we are going to see is a robot based on RF module for pick and place. A pick and place robot is the one which is used to pick up an object and place it in the desired location. We have shown that how we can control the movement of the robot with the help of an RF Module. RF Modules are used for wireless transfer data. It is suitable for remote controlling applications, where you need for controlling some machines or some robots without getting in touch with them. Here we are controlling all the movement of the robot by using transmitter which is equipped with encoder circuit, radio frequency transmitter. On the other hand at the receiver end we receive the data also control the motors used for the required movement.

The second we are going to see is obstacle detection using sensor. The sensor provides high immunity from ambient light and can be used in all light conditions quite effectively. Obstacle detection systems typically compute the position of obstacles relative to a mobile agent by using range information.

The next robot we are going to see is the robot used for fire sensing. Loss due to fire damage has always been a major area of concern for both industrial and residential areas. Fire detection is done by circuit containing LM35 and AVR microcontroller. This paper covers the design and construction of a robot that is able to sense fire and inform to fire bridge. It was determined that the use of robot equipped with advanced fire detection technology can minimize cost, reduce false alarms, and be highly extensible to other industries. With the rapid development of technology and innovation, there has been increased focus on the area of fire detection throughout the past few decades.

A wireless RF Camera is attached to the head of the robot to provide surveillance. However, the robot consists of RF Camera and at the workstation, the receiver is connected to the computer by using the TV Tuner Card. The different live images can be viewed and adequate measures or emergency operations can be carried out saving lives. The robot is built using steel and aluminium alloy which can resist high temperatures, and protecting the circuit.

One more function of these project is for theft detection during night time. The theft detection consist of two circuitary first consist of IR sensor place on window and doors of workplace and second one placed on robot which consist of LDR sensor and GSM Module. GSM Module will helps to indicate control and security room there is theft in workplace. It provide more security to the workplace.

## TECHNICAL REQUIREMENTS

The technical requirements which are chosen as a basis. They are for the efficient functioning of the system which are as follows:

### RF Module

RF Modules is used wireless data transfer. An RF module which is also called as (radio frequency module) is a small electronic device which is used for transmission and/or receiving radio signals between two communicating devices. In an embedded system it is often desirable for communication with another device. This wireless communication can be accomplished through optical communication or it may be through Radio Frequency communication. RF communications includes a transmitter and/or receiver.

An RF transmitter module is a nothing but small PCB sub-assembly which is capable of transmitting a radio wave along with modulating that wave for carrying data. Transmitter modules are mostly implemented alongside a micro controller which also provides data for the module which can be transmitted. RF Transmitters are mostly subjected to regulatory requirements which are used for dictation of maximum allowable transmitter power output along with harmonics, and band edge requirements.

An RF Receiver module is used to receive the modulated RF signal, and also demodulates it. There are mainly two types of RF receiver modules. they are as follows: superheterodyne receivers and super-regenerative receivers. Super-regenerative modules are generally low cost and low power designs made up of using a series of amplifiers for extracting modulated data from a carrier wave. Super-regenerative modules are usually imprecise because of their frequency of operation varies considerably along with temperature and also with power supply voltage.

- Range in open space(Standard Conditions) : 100 Meters
- RX Receiver Frequency : 433 MHz
- RX Supply Current : 3.5 mA
- RX IF Frequency : 1MHz
- RX Operating Voltage : 5V
- TX Frequency Range : 433.92 MHz
- TX Supply Voltage : 3V ~ 6V

- This has single channel for data transfer, so serial data communication is used

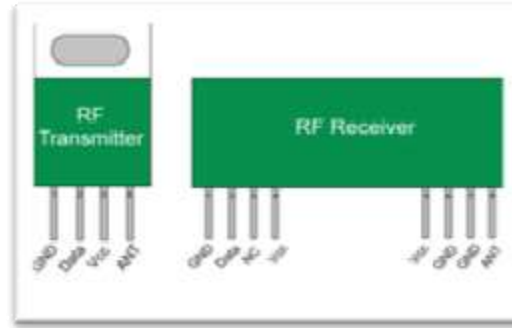

Figure 1. RF Module

### Serial Encoder/Decoder

The most popular serial encoder/decoder which used is the HT12D-HT12E pair. The HT12E Encoder ICs are nothing but series of CMOS LSIs used for Remote Control system applications. They are having capability to encode 12 bit of information which consists of N address bits and also 12-N data bits. Each of the addresses along with data input is externally trinary programmable if it is bonded out.

The HT12D Decoder ICs are series of CMOS LSIs which are used for remote control system applications. This ICs are paired with one other. For performing proper operation a pair of encoder/decoder along with the same number of address and data format must be selected. The Decoder is used to receive the serial address and also data from its corresponding encoder, which is transmitted by a carrier using an RF transmission medium .It gives output to the output pins when processing the data is over.

### Voltage regulator

We used LM7805 voltage regulator. The output current of 1.5A can be delivered by each of these stated regulators. The immunity for overloading is provided by means of the internal current-limiting as well as thermal shutdown features of the regulators. Generally, number "78" denotes positive voltage output and the given last two digits represent the output voltage which it will produce. Also with these devices can be cascaded arranged in parallel with the peripheral components for attaining adjustable output voltages and currents too. Figure 2 depicting the pin out of LM7805.

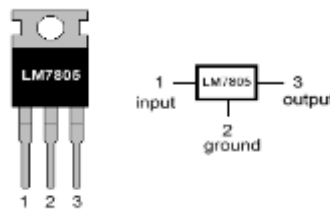

Figure 2. LM7805 Pinout diagram

### LDR

A Light Dependent Resistor (aka LDR, photoconductor, photocell, or photo resistor.) which is a device, has a resistance which always varies in accordance to the amount of light falling on the surface, when light falls upon it then value of resistance changes. Light dependent resistors are often used in the circuits where it is necessary for detection of the presence of light and the ambient level of light often for creation of a light triggered switch.

It is different for the values of resistances of an LDR to be in meg ohms in darkness and then used to fall to a few hundred ohms in the bright light. With such a wide variation found in resistance, LDRs are easily usable and there are many LDR circuits available in the market. LDRs are made from various semiconductor materials for enabling them so as to have their light sensitive properties with a very high resistance. Many materials are be used, but one most popular material used for these LDR's is a cadmium sulphide (CdS).

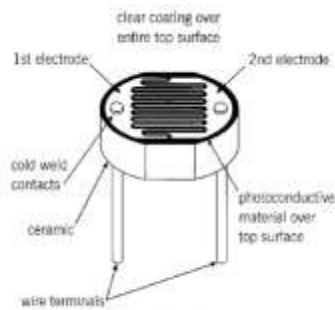

Figure 3. Typical construction of LDR

### LM35

The LM35 series are nothing but a precision integrated-circuit temperature sensors. It has an output voltage which linearly proportional to the Centigrade temperature and has Linear + 10 mV/°C Scale Factor. Thus we can say LM35 has an advantage over linear temperature sensors which are calibrated in ° Kelvin, because user is not required to subtract a large constant voltage from the output for obtaining convenient Centigrade scaling too. LM35 have 0.5°C ensured Accuracy provided at +25°C. The LM35 doesn't require any external calibration and trimming for providing a typical accuracies of  $\pm 1/4^\circ\text{C}$  at room temperature and the accuracy of  $\pm 3/4^\circ\text{C}$  over a range of  $-55^\circ\text{C}$  to  $+150^\circ\text{C}$  temperature. Low cost is guaranteed by trimming and calibrating at the water level. The low output impedance and linear output and precise inherent calibration of the LM35 used for making interfacing for readout or control circuitry. The device is used with just a single power supplies, or also with plus and minus supplies. LM35 draws only 60  $\mu\text{A}$  from the provided supply, has very low self-heating of less than 0.1°C in the still air. The LM35 is rated for operation of over a  $-55^\circ\text{C}$  to  $+150^\circ\text{C}$  temperature range. It has 4 to 30V voltage range. It has low impedance output, of 0.1  $\Omega$  for 1 mA Load.

### LM324

The LM324 series are having low-cost, quad operational amplifiers having true differential inputs. The LM324 is compensated internally and short circuited as well as protected outputs IC. It has low input bias currents of values 100 nA maximum. They are having several advantages over standard operational amplifier which are types in single supply applications. The quad amplifier can be operated at supply voltages as low as 3.0 V or it may be as high as 32 V with a quiescent currents of about one-fifth of these associated with the MC1741. The common mode input range which also includes the negative supply and thereby eliminating the necessity to external biasing components in much more applications. The output voltage range includes the negative power supply voltage.

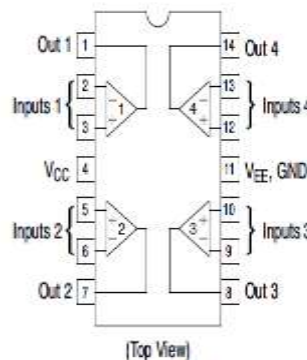

Figure 4. Pin connection of LM324

### Motor Driver

Any motor needs to be provided with certain voltage. When a motor is interfaced with a microcontroller or processor, it need extra current as compared to the microcontroller pin which can typically generate for running. A basic approach for this is for providing a switch which accepts a small current. It amplifies generates a larger current which is required to drive a motor. Thus entire process is done by a motor drive also.

L293D is a typical Motor driver which also allows DC motor used to drive in both of the clockwise and also anticlockwise direction. L293D is a 16-pin IC .It can control a set of two DC motors simultaneously in any of the direction. It is a dual H-bridge Motor Driver integrated circuit (IC) .Its operation is given by in the Table 1. L293D which has an output current capability limited only upto 600mA per channel with a peak of output current limited to 1.2A, sufficient enough for driving a 100rpm motor. An internal sensor senses its internal temperature and also stops driving the motors if the temperature crosses a set point which are used to implies that the over temperature protection is also for built into the IC. Zener diodes are also used for protecting the driver IC from the voltage spikes which occur when the motor is turned on or off.

TABLE I. Operation of L293

Input1	Input2	Operation
0	0	Stop
1	0	Clockwise
0	1	Anticlockwise
1	1	stop

**AVR Microcontroller**

Microcontroller is the main part of an embedded system. The Atmega16 is a low-power CMOS 8-bit Microcontroller which is based on the AVR enhanced RISC architecture. After execution of powerful instructions in a single clock cycle, then ATmega16 achieves throughputs approaching 1 MIPS per MHz which allows the system which are designed for optimizing power consumption verses processing speed. The AVR core combines with a rich instruction set with 32 general purpose working registers. Total 32 registers are directly connected to the Arithmetic Logic Unit (ALU), which allows two independent registers which are accessed in one single instruction executed in one clock cycle. The architecture found after result is more code efficient and achieving throughputs up to ten times faster than that of the conventional CISC

microcontrollers.



Figure 5. Pin diagram of AVR microcontroller

The ATmega16 features a 10-bit successive approximation ADC. ADC is connected to the 8-channel Analog Multiplexer which allows the 8 single-ended voltage inputs which constructed from the pins of Port A. The single-ended voltage inputs is referred to 0V (GND). The ADC consists of a Sample and Hold circuit which ensures that the input voltage given to the ADC is held at a constant level during the process of conversion. The ADC has a separate analog supply voltage pin and also AVCC. AVCC must not differ more than ±0.3 V from that of VCC. See the paragraph of “ADC Noise Canceler” which is mentioned on page 206 on how to connect this pin. Internal reference voltages of nominally 2.56V or AVCC are always provided On-chip. The voltage reference is externally decoupled at pin AREF by a capacitor for used for better noise performance.

## Global System for mobiles

The GSM Modem can be used to accept any GSM network operator SIM card and act like as a mobile phone with its own unique phone number. The RS232 port is used for communication and development of embedded applications which is an extra advantage of this modem. Applications like as data transfer, SMS Control, remote control and also logging can be developed in an easy way. The modem is directly connected to a PC serial port or any microcontroller. Sending and receiving of SMS can be done by using this modem. GSM SIM 300 Modem GSM/GPRS Modem TTL are built with dual band GSM/GPRS engine SIM 300 which works on frequencies 900/1800 MHZ. The Baud rate is configurable from the value of 2400-115200 through AT command. The GSM /GPRS modem is having an internal TCP/IP stack which enables to connect with internet via GPRS. It can be used for SMS also Voice as well as Data transfer application in M2M interfaces. The commercially available GSM is SIM 300 dual-band GSM/GPRS 900/1800 MHZ. It has features like

- It has Configurable baud rate
- It can be controlled through standard AT commands
- A SIM card holder
- An Inbuilt powerful TCP/IP Protocol stack internet data transfer over GPRS
- A Normal operation temperature: -20 C to +55 C
- An Input Voltage: 3.6V -4.5V DC

## IMPLEMENTATION

The proposed robot is wheel base robot which has arm on the front side and which can rotate through 180 degree. The robot has the mechanical structure which is composed of set of four wheels and two arms which are attached to the front. For the movement of the robot in forward, left, right, clockwise and anticlockwise direction 12V DC motors of 120 rpm are used. Movement of the arms close or open is carried out by 12V DC motors of 10rpm .

We have a transmitter for controlling the robot with a RF MODULE for forward, backward, left, right movements and arms movement. A block diagram of transmitter section is shown in figure 6.

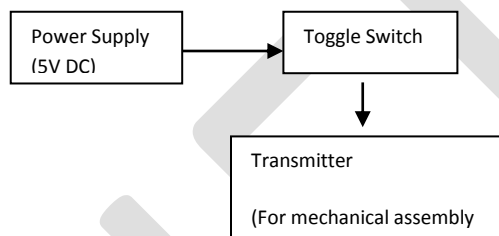

Figure 6. Transmitter Section

At the receiver end we receive the data and then this data is decoded by a decoder, then through microcontroller the signals goes to the motor driver and we get the desired movements. A block diagram of receiver section is as shown in figure 7. Here we use 433MHz of radio frequency. In this project we use one encoder IC HT 12 E to encode data. The transmitter converts the data from decimal to binary into 12 bit code. The parallel signals as the output of the encoder are then fed to the RF module. RF module here is capable of transmitting the signals wirelessly. So the RF module transmits the signals wirelessly into the free space via the transmitting antenna. The ASK modulation is done by the RF itself. In the receiver circuit we use one decoder IC. This IC is HT 12 D. First of all data is to be received by the RF module and then connected to the decoder IC.



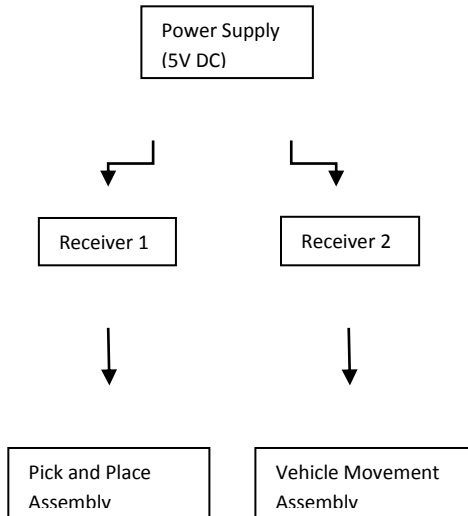

Figure 7. Receiver section

In this robot as LM35 is connected to the AVR microcontroller. LM35 senses the fire or increase in temperature after certain limit microcontroller will receives the signal a buzzer sounds, the buzzer sound is to intimate the occurrence of fire accident. After the sounding of the buzzer microcontroller actuates the driver circuit and it connect to the GSM module which will send message to the fire bridge.

Some IR sensors are connected across door and window of the workplace. When door or window is close, there will be continuous transmission of the Infrared signal. But when door or window opens then transmission of Infrared signal stops then through receiver circuit one relay is connected which will turns ON bulb in the workplace. LDR is used to detect the light. When light is detected buzzer sounds, buzzer and light is to intimate the occurrence of theft in the workplace. It also connected to the GSM module which will send message to the control and security office. A block diagram of sensing and detection system shown in figure 8.

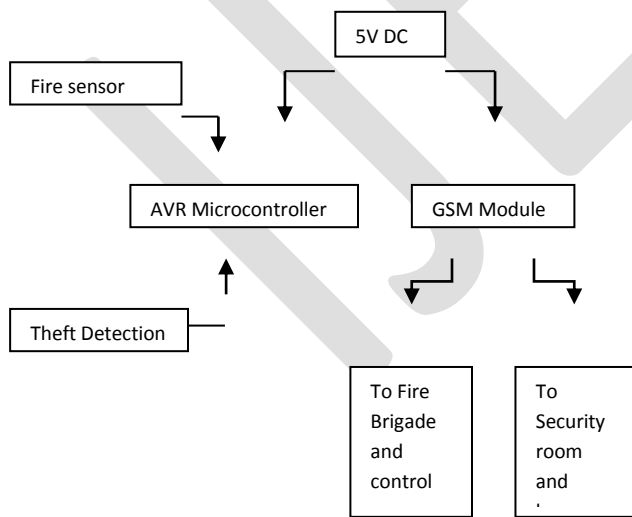

Figure 8. Sensing and detection system

This robot uses infrared sensor for detection of the obstacle in between the path and then avoid them to complete its objective. The IR transmitter continuously generate an Infrared signal, when an obstacle comes in the path the infrared signal reflected back from the object and is received by the IR sensor and then generating a positive high signal with the help of the receiver circuit which indicates that there is an obstacle in the path. In such a way the robot is able to detect obstacles of provided space and able to avoid obstacles coming in between the path of ROBOT.

#### CONCLUSION

This robot is able to produce the basic walking movements using four dc motors and arm movement for pick and place using 2 dc motors. A robot is developed with a very good intelligence which is easily capable to sense the obstacle and by processing the signal coming from the sensor it is perfectly avoiding the obstacle coming in between the path. In future, the sensing range can be increased by increasing the sensor quality with the help of ultrasonic sensor or the IR signal spread all over the provide area. It is capable of sensing fire in the workplace which provide protection of workplace from natural hazards. In future we can also add the system which will extinguish fire and can be extended to a real fire extinguisher by replacing the water carrier by a carbon-di-oxide carrier and by making it to extinguish fires of all the room using microcontroller programming. Robotic vehicle is capable for theft detection. It provide safety to the workplace. It also provide continuous monitoring system through which user can observe condition in the workplace in the control room.

#### REFERENCES:

- [1] Deepak Kuma, Digvijay Singh, Ms. Ghazala Ansari, "RF and GSM Controlled Spy ROBO with Wireless Nigit Vision Camera and Fighting Weapon" in Internal Journal Of Engineering Research & Management Technology, Volume-1, Issue-2, March 2014.
- [2] U.Jyostna Sai Prasanna, M.V.D.Prasad, "Automatic Fire Sensing and Extinguishig Robot Embedded With GSM Modem", International Journal of Engineering and Advanced Technology (IJEAT) ISSN: 2249 – 8958, Volume-2, Issue-4, April 2013
- [3] Rakesh Chandra Kumar, Md. Saddam Khan , Dinesh Kumar, Rajesh Birua, Sarmistha Mondal, ManasKr. Parai, "OBSTACLE AVOIDING ROBOT – A PROMISING ONE", International Journal of Advanced Research in Electrical, Electronics and Instrumentation Engineering Vol. 2, Issue 4, April 2013
- [4] M. A. Meor Said, M.A.Othman, M.M.Ismail, H.A.Sulaiman, M.H.Misran, Z.A. Mohd Yusof, "Wireless Controlled Omnidirectional Monitoring Robot With Video Support", International Journal of Engineering Research and Applications, Vol. 2, Issue4, July-august 2012
- [5] Kunal Borker, Rohan Gaikwad , "Wireless Controlled Surveillance Robot", International Journal of Advance Research in Computer Science and Management Studies Volume 2, Issue 2, February 2014.
- [6] Harish Chandra Mohanta, Rajat Kumar Mahapatra, Jyotirmayee Muduli, "Anti-Theft Mechanism System with Accidental Avoidance and Cabin Safety System for Automobiles", International Refereed Journal of Engineering and Science, ISSN-2319-183X Volume 3, Issue 4, April 2014.
- [7] Love Aggarwal Varnika Gaur Puneet Verma, " Design and Implementation of a Wireless Gesture Controlled Robotic Arm with Vision", International Journal of Computer Applications, Volume 79 – No 13, October 2013