

BIDIRECTIONAL DUAL ACTIVE BRIDGE LCL RESONANT CONVERTER WITH FUZZY LOGIC CONTROLLER

¹S.Benilah and ²A.CoredillaSumathy

¹Department of Electrical and Electronics Engineering, Francis Xavier Engineering college

benilah@gmail.com contact no:9442935012

²Assistant professor Department of Electrical and Electronics, Francis Xavier Engineering College

Abstract— This project presents a bidirectional LCL resonant converter with dual active bridge for dc distribution applications. This converter allows both forward and reverse power transfer between the source and the load. To maintain the output voltage constant, irrespective of load and line disturbances, it is necessary to operate the converter as a closed loop system. In recent years, the Fuzzy Logic Controller (FLC) has become more popular due to its simplicity, automated control and need of less skilled labour. The proposed FLC for bidirectional DC to DC converter is validated through simulation in Matlab/Simulink environment. A hardware setup is also developed to validate the simulation.

Keywords— DC-DC Converter, Bidirectional power, LCL, Fuzzy logic, Dual active bridge.

INTRODUCTION

Power electronic circuits primarily process the energy supplied by a source to match the form necessary by the load, by means of using semiconductor devices to regulate the voltage and current. The energy is usually available from the utility grid or from a bank of batteries with the applications ranging from high-power conversion equipment processing megawatts to everyday low power equipment with requirements of a few milliwatts. With rising importance on compact, smaller and effective power systems there is increasing attention in the possibility of using bi-directional converters [1], [3]-[5], particularly in DC power based applications like planetary, telecommunication and computer systems. In[2], an auxiliary switch control for bidirectional dc converter is presented to improve the efficiency of the converter which can be used in electric vehicle. High power isolated bi-directional DC-DC converters afford galvanic isolation, V2G capability and diminish the cost and impression of the system. Maintaining high power efficiency in wide vehicle battery pack voltage range is required. Three full bridge based high power bidirectional DC-DC converters are conceptually designed for this application [6]. According to a recent report from the IEA, fossil fuels are subsidized at a rate about five times greater than renewables. Just as cellular telephony has brought telecommunications to remote parts of the globe that never had access to the technology before, distributed generation system offers hope for progress and a better standard of living for millions of people that have never had the opportunity before [7]. A current sourced bidirectional inductive power transfer interface which is suitable for simultaneous contactless charging / discharging of multiple electric vehicles or equipment [8]. A dual phase shift algorithm for DAB converter in whole operation range covering wide voltage ratio of primary and secondary side DC-link, whole possible duty ratio and phase shift angle is used in [9]. A bidirectional inductive power transfer system is used as the wireless interface between the electric vehicle and the DC bus while a bidirectional DC-DC converter serves as an interface between the battery system and DC bus to store and retrieve energy [10]. Bidirectional DC converter with single or three phase input, power factor correction for single phase input, controllable power factor for three phase input, isolation and voltage matching with high-frequency transformer that offers low volume, weight and cost is analysed in [11]. The control algorithms for bidirectional DC converter are Dual-Phase-Shift Control (DPSC), Model-based Phase-Shift Control (MPSC) and enhanced MPSC [12]. The intelligent technique based controlling strategy improves the dynamic behaviour of the converter [13]. Furthermore, several soft-switching converter topologies such as series/parallel resonant, dual active bridge, phase-shifted bridge, auxiliary resonant commutated bridge and hard switching PWM have been proposed [14], [15].

In this paper, a resonant bidirectional dual active bridge topology applied with soft switching technique is proposed. Bidirectional dc-dc converters exhibit as an ever-lasting key component to interface between a high-voltage bus and a low voltage bus. The two buses are interconnected by a bidirectional dc-dc power converter to permit power flow in both directions thus enabling the excessive energy to be stored in the battery and later delivered back to the system when it is necessary. Therefore, in order to connect those buses while keeping reduced volume, weight and cost, a high power density, high efficient bidirectional dc/dc converter is required and the analysis and design of a proposed solution based on Fuzzy Logic Controller is the subject of this paper.

PROPOSED TOPOLOGY

This paper proposes a bidirectional DC – DC converter controlled by Fuzzy Logic Controller. The circuit diagram of the proposed bidirectional converter is shown in Fig.1. For simplicity, the active source is represented by dc source which can be a PV system. The bidirectional DC converter allows both forward and reverse power transfer between the source and the load. During forward power transfer, bridge converter 1 acts as inverter and the other converter acts as rectifier and vice versa during reverse power transfer. The dynamic behaviour of the system can be improved by the application of Fuzzy Logic Controller

BIDIRECTIONAL DC CONVERTER (BDC) WITH LCL NETWORK

Fig.2 shows the block diagram of the bidirectional DC converter which consists of a high frequency transformer and two bridge converters located on the primary and

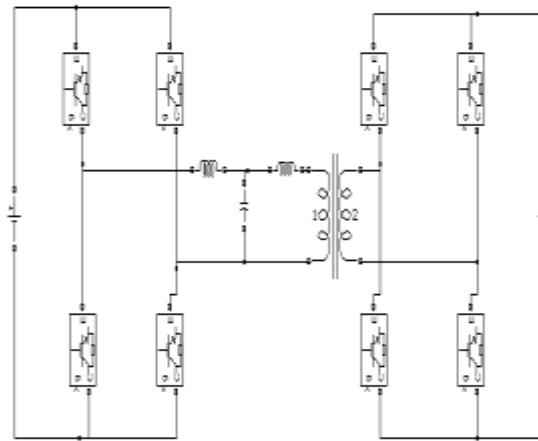

Fig.1. Proposed BDC converter

secondary sides of the transformer. The high frequency transformer provides the required isolation and voltage matching between the low and high voltage buses. The transformer leakage inductance serves as the instantaneous energy storage device. The operation is bidirectional, that is, each bridge converters can be considered as primary or secondary depending on the direction of power flow.

Applications that require exchange of power from the source to the load and viceversa have conventionally been implemented with two unidirectional converters; each processing the power in one direction. Then they are implemented by soft switching and resonant techniques. But it increases the component rating, circuit complexity and its losses. To overcome these difficulties bidirectional converter is proposed which has the advantage of low stress on switches, galvanic isolation and reduced components count. The BDC is located between the high voltage bus and the low voltage bus which is also connected to DC loads such as anti-lock brakes, fans, electric power steering, heated seats and electronic ignition in the vehicle.

Apart from out-dated applications in DC motor drives, novel applications of BDC comprise energy storage in renewable energy storage systems, fuel cell systems, hybrid electric vehicles (HEV) and uninterruptible power supplies. In HEV applications, BDCs are required to link different dc voltage buses and transfer energy between them.

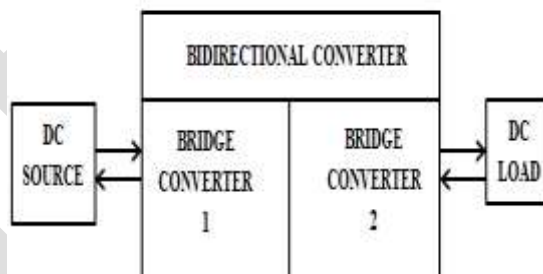

Fig.2 Block Diagram of BDC

High efficiency, less weight, compact size and high consistency are certain significant necessities for the BDC used in such applications.

At high frequencies, DC – DC converters experience high switching losses, reduced reliability, EMI and acoustic noise. These switching losses can be reduced by introducing a resonating tank circuit. The so called converters with resonating tank circuit are series resonance converters (SRC) and parallel resonance converters (PRC). In these converters, the tank circuit is made up of simple L and C components connected either in series or parallel to the load. Though SRC has better load efficiency, it suffers from poor load regulation. On the other hand, in PRC no load regulation is possible but it also suffers from poor load efficiency and lack of DC blocking for the isolation transformer. Moreover, both SRC and PRC draws large reactive current component and therefore incur large conduction losses. Therefore, in this paper it has been suggested to design resonant converter with three resonating component (LCL) for better voltage regulation.

MATHEMATICAL MODELLING OF LCL NETWORK USING STATE SPACE TECHNIQUE

The equivalent circuit of LCL network is shown in Fig.3. The mathematical modelling using state space technique can be obtained assuming all the components to be ideal.

The vector space equation for the converter is

$$\dot{X} = AX + BU \quad (1)$$

Where

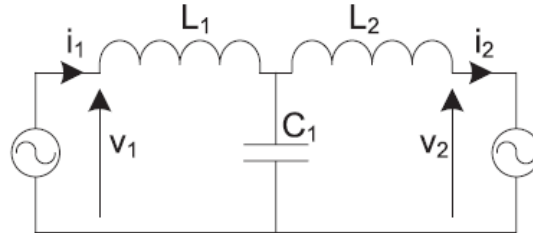

Fig.3 Equivalent circuit model of LCL network

$$\dot{X} = \frac{d}{dt} \begin{bmatrix} i_{L_1} \\ V_C \\ i_{L_2} \end{bmatrix}, X = \begin{bmatrix} i_{L_1} \\ V_C \\ i_{L_2} \end{bmatrix}, U = \begin{bmatrix} V_i \\ V_o \end{bmatrix}$$

The state space equation can be obtained from the Fig.3. The state equation for LCL converter is

$$\frac{di_{L_1}}{dt} = \frac{mV_i}{L_1} - \frac{V_C}{L_1}$$

$$\frac{dV_C}{dt} = \frac{1}{C} (i_{L_1} - i_{L_2})$$

$$\frac{di_{L_2}}{dt} = \frac{-nV_o}{L_2} + \frac{V_C}{L_2}$$

Where

$$A = \begin{bmatrix} 0 & -1 & 0 \\ \frac{1}{C} & 0 & -1 \\ 0 & \frac{1}{L_2} & 0 \end{bmatrix}, B = \begin{bmatrix} \frac{m}{L_1} & 0 \\ 0 & 0 \\ 0 & \frac{-n}{L_2} \end{bmatrix}$$

Equation (1) can be written as

$$A = \begin{bmatrix} 0 & -\frac{1}{L_1} & 0 \\ \frac{1}{C} & 0 & -\frac{1}{C} \\ 0 & \frac{1}{L_2} & 0 \end{bmatrix}, B = \begin{bmatrix} \frac{m}{L_1} & 0 \\ 0 & 0 \\ 0 & -\frac{n}{L_2} \end{bmatrix}$$

$$\frac{d}{dt} \begin{bmatrix} i_{L_1} \\ V_C \\ i_{L_2} \end{bmatrix} = \begin{bmatrix} 0 & -\frac{1}{L_1} & 0 \\ \frac{1}{C} & 0 & -\frac{1}{C} \\ 0 & \frac{1}{L_2} & 0 \end{bmatrix} \begin{bmatrix} i_{L_1}(t) \\ V_C(t) \\ i_{L_2}(t) \end{bmatrix} + \begin{bmatrix} \frac{m}{L_1} & 0 \\ 0 & 0 \\ 0 & -\frac{n}{L_2} \end{bmatrix} \begin{bmatrix} V_i \\ V_0 \end{bmatrix}$$

FUZZY LOGIC CONTROLLER (FLC)

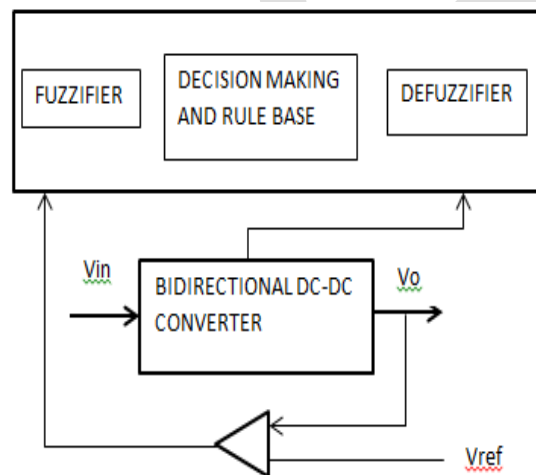

Fig.4 Block diagram of FLC

Fig.4 shows the block diagram of the FLC. In FLC, basic control action is determined by a set of rules. These rules are determined by the system. Meanwhile the numerical variables are converted into linguistic variables, mathematical modelling of the system is not required in fuzzy control. Converter circuits contain non – linearities like delay, overshoot, large settling time, rise time etc. Due to these non-linear characteristics of DC – DC converters, linear controllers do not allow disturbance rejection and also possess slow response time. So, there is more interest in using non-linear control techniques to improve the performance of the DC – DC converters. The process of FLC design includes the following process.

- (i) Fuzzification: Process of representing the inputs as suitable fuzzy value.
- (ii) Decision Making: Appropriate control action to carried out. It is based on the knowledge base and rule base.
- (iii) Defuzzification: Method of converting fuzzified output into crisp value.

The inputs to the FLC are error signal and difference of error signal. The output is the duty ratio of the switching signal.

$$E(k) = V_{ref} - V_o$$

$$CE(k) = E(k) - E(k - 1)$$

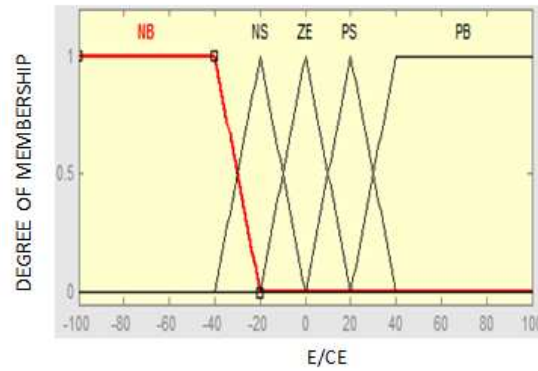

Fig.5 Membership functions of Error input (E) and Change in error(CE)

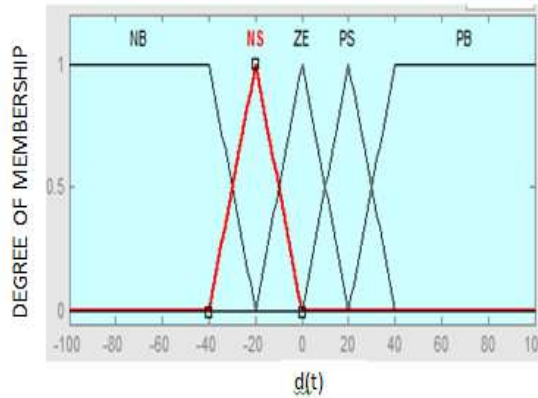

Fig.6 Membership functions of output duty cycle.

$$d(t) = d(t - 1) - d(X(t))$$

Where

- $E(k)$ – Error signal
- $CE(k)$ – Change in error signal
- $E(k - 1)$ – Previous error signal
- $d(t)$ – Duty cycle at t_{th} instant
- $d(t - 1)$ – Duty cycle at $(t-1)$ instant
- $d(X(t))$ – Change in duty cycle

Mamdani type controller is selected for this application and the basic rule of this type of controller is :

IF e is A and de is B THEN d(t) is C
Where A and B –Fuzzy subsets
C – Fuzzy singleton

The universe of discourse is distributed into five subsets such as Negative Big(NB), Negative Small(NS), Zero(ZE), Positive Small(PS), Positive Big(PB).

The Fig.5 shows the membership functions of the inputs. To maintain the voltage at desired level the triangular membership of error and control output are cramped near to zero for the given operating condition. For improving the controller performance, membership functions are further adjusted based on trial and error method. Fig.6 shows the membership functions of the output variable

SIMULATION RESULTS

In this section, the Matlab/Simulink simulation results for different operation modes of the bidirectional converter that interfaces the load to the source is shown. The proposed BDC converter operation and the closed loop FLC performance are also modelled.

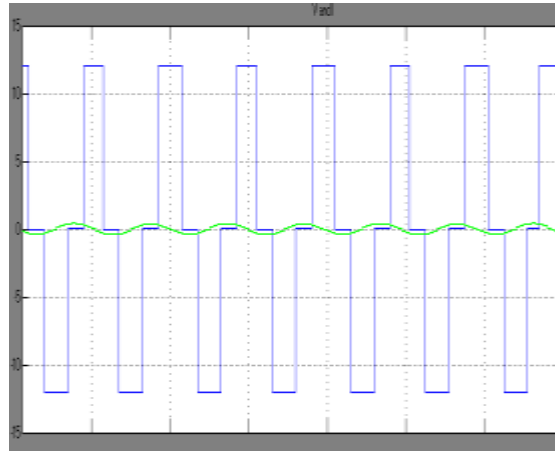

Fig.7 Output of the inverter during both forward and reverse mode

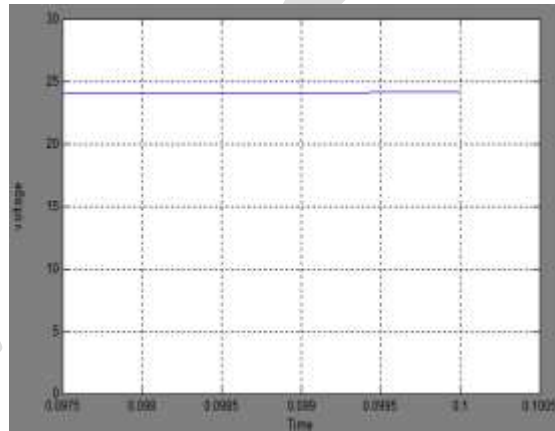

Fig.8 DC output during forward mode

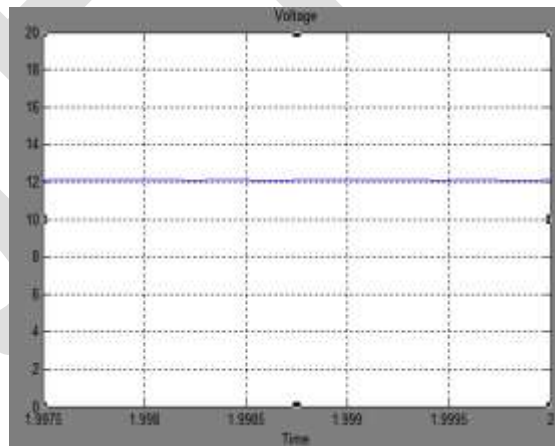

Fig.9 DC output during reverse mode

Fig.7 demonstrates the output of the inverter with voltage and current in the same axis. This output is given as a input to the lcl resonant network and then to the load via the bridge converter which acts as a rectifier.

Fig.8 and Fig.9 illustrate the closed loop performance of the converter. In a bidirectional system, the response of the system to power flow in both the forward and reverse direction is also important. The closed loop result analysis clearly shows that, the output voltage get stabilizes at faster rate to the desired value (24V) in boost mode. Similarly in buck mode, output voltage get stabilizes at very faster rate to the desired value (12V)

CONCLUSION

In this project work, LCL resonant network is used in bidirectional DC – DC converter. This resonant technique is used in full bridge as well as half bridge converters. The proposed converter is devoid of the transistors switching power dissipation within the whole operating range, therefore it is measured by high efficiency. In order to obtain the desired operating voltage irrespective of the source and load disturbances the converter must be operated in closed loop. All these problems are efficiently dealt with FLC. The FLC controller regulates the output voltage and helps in achieving smooth transition between the two operation modes of the bidirectional converter, namely buck and boost mode. Fuzzy control method does not need accurate mathematical model of a plant and hence, it outfits well to a process where the model is unknown or ill-defined. This system can be used for applications such as space and radar applications.

REFERENCES:

- [1] Ancy A. M, Siby C Arjun, "A resonant converter topology for bidirectional DC - DC converters," International journal of engineering research and technology, Vol. 3, Issue 9, Sep 2014.
- [2] K. Kaviarasu, Shilpa Rajan T. V, "Auxillary switch control for bidirectional DC - DC converter," International journal for technology research in engineering, Vol. 1, Issue 10, June 2014.
- [3] K. Ramya, R. Sundaramoorthi, "Bidirectional power flow control using CLLC resonant converter for DC distribution system," International journal of advanced research in electrical, electronics and instrumentation engineering, Vol. 3, Issue 4, April 2014.
- [4] J. Park, M. Kwon and Sewan Choi, "Design and control of a bidirectional resonant DC – DC converter for automotive engine/battery hybrid power generation," Seoul National university of science and technology, 2013.
- [5] A. Salami and E. Rexaei, "A novel ZVS bidirectional DC – DC converter for fuel cell applications," International journal of information and electronics engineering, Vol. 3, no. 3, May 2013.
- [6] D. Yu, S. Lukic, B. Jacobson, and A. Huang, "Review of high power isolated bidirectional DC – Dc converters for PHEV/EV DC charging infrastructure," in Proc.IEEE Energy Convers.Congr.Expo.,2011.
- [7] J. Marsden, "Distributed generation systems: A new paradigm for sustainable energy," in Proc.IEEE Green Technol. Conf.,2011
- [8] U. K. Madawala and D. J. Thrimawithana, "A bidirectional inductive power interface for electric vehicles in V2G systems," IEEE Trans. Ind. Electron., Vol. 58, no. 10, Oct. 2011.
- [9] K. Myoungho, M. Rosekeit, S. Seung-Ki and R. W. A. A. De Doncker, "A dual-phase-shift control strategy for dual-active-bridge DC – DC converter in wide voltage range," in Proc. IEEE Power Electron. Energy Convers. Congr. Expo. Asia,2011.
- [10] D. J. Thirmawithana and U. K. Madawala, "A model for a multi-sourced green energy system," in Proc. IEEE Conf. Sustainable Energy Tehnol.,2010.
- [11] N. D. Weise, K. K. Mohapatra, and N. Mohan, "Universal utility interface for plug-in hybrid electric vehicles with vehicle-to-grid functionality," in Proc.IEEE Power Energy Soc. Gen. Meeting, 2010.
- [12] B. Hua, N. Ziling, and C. C. Mi, "Experimental comparison of traditional phase-shift, dual-phase-shift, and model-based control of isolated bidirectional DC – DC converters," IEEE Trans. Power Electron., Vol. 25, no. 6, Jun 2010.
- [13] N. Raja rajeswari and K. Thanushkodi, "A high performance DC – DC converter with battery charging circuit," The pacific journal of science and technology, Vol. 9, no. 2, Nov 2008.
- [14] R. L. Steigerwald, R. W. De Doncker, and H. Kheraluwala, "A comparison of high-power DC – DC soft-switched converter topologies," IEEE Trans. Ind. Appl., Vol. 32, no. 5, Oct. 1996.
- [15] R. W. A. A. De Doncker, D. M. Divan, and M. H. Kheraluwala, "A three-phase soft-switched high-power-density DC – DC converter for high-power applications," IEEE Trans. Ind. Appl., Vol. 27, no. 1, Feb 1991.