

Research and Development of ERS Cutting Machine

¹Mr.Dhanapal S, ²Mr.Manikandan T

¹M.E.Applied Electronics, ²Asst.Prof- Department of Electronics and Communication Engineering, Jay Shriram Group of Institution, Tirupur, Tamilnadu. ¹dhanapal6sb@gmail.com, ²mani.siva88@gmail.com

Abstract— It is observed that garment elastic cutting methods are not fully successful due to the given measurement for elastic length was not cut properly. And also no such machine in an Indian make. The main objective of this proposed system is to avoid elastic shrinkage problem and reduces the machine cost and also save the machine importing cost. This machine is particularly useful for small and medium size serial productions, where flexible and automated cutting solutions for Elastic and VELCRO tape are required. This ERS (Elastic, Rope, and Shoe lace) cutting machine provides a best cutting solution for garment technology with cheapest price.

Keywords— VELCRO, garment elastic cutting, shrinkage

INTRODUCTION

The purpose of this research is to design, fabricate, test, and evaluate the prototype of a semi-automatic ERS cutting machine. The design concept is that ERS cutting is accomplished by pneumatic press on an ERS sitting on a sharp knife in a horizontal plane. The machine consists of 5 main parts: 1) machine frame, 2) cutting base, 3) sensing unit, 4) pneumatic system, and 5) stacker receiving cutting pieces. In operation, Elastic is placed on the cutting base and the pneumatic control is switched on. The Elastic is automatically moved to the sensing unit and by a knife set. The cutting piece flows down to the stacker. The machine is found to operate safely without damage to the pieces. Easy to load new elastic using elastic feed roller for the selected elastic length. Elastic length can be programmed and managed offline on. Equipped with an IR sensor virtually eliminates shrinkage mistakes. Easy insertion of the Elastic, cycle start by means of an automatic sensor, and the ability to clearly view the entire operation through the safety shield further add to the user-friendliness. Precision mechanics coupled with new generation electronics guarantee repeatable cutting quality. The cutting head accepts different blade types. Blades can be changed quickly and easily without any tools.

Draw backs of Existing System

1) Output Accuracy

Today's Existing System are all not provide correct measurement in given length, because of the Elastic shrinkage problem

2) Cost

Machine cost is so high for all garment exporters. No Such a brand in India, therefore machine importing cost and duty clearance charges also included

3) Optional Devices

Optional Devices like twisting bar, Stacker are extra charges as per the customer requirement

4) Thickness of the Cutting material

Existing System are all not suitable when thickness of the cutting material is greater than 3.5mm

PROPOSED SYSTEM

The automatic cutting machine ERS Cutting Machine is useful whenever Elastic/Velcro tape is used (e.g. safety wear, medical products, and bags). ERS Cutting Machine has an automatic material feed system. Depending on the cutting length it is

possible to have up to 60-80cuts/min. The cutting is done by a customized cutting tool, which can handle a material width of 100mm maximum. The cutting tool is individualized and can be designed for various patterns (e.g. rounded arrow shape, semi-circles, and other customized shapes). Additionally, it is possible to employ a compound-cutting die in order to cut two tapes parallel resulting in a higher productivity.

In order to increase the flexibility of the cutting machine, it is possible to easily swap cutting tools. It is also very simple to set up the machine by entering the cutting length and the quantity. These features make it easy to respond to changes in the final product design. Due to the very easy handling of the machine, small quantities of a certain tape length can be cut efficiently. This helps to reduce the stock of pre-cut material. The device is also equipped with a roll holder as well as an integrated auto-stop function in case the tape material runs out.

The ERS Cutting Machine is a compact-designed and portable cutting machine for any kind of Elastic and VELCRO tape. A regular 220V power connection, very little space required, and no compressed air make it easy to employ it at any production site.

The machine is particularly useful for small and medium size serial productions, where flexible and automated cutting solutions for Elastic and VELCRO tape are required. . Easy insertion of the Elastic, cycle start by means of an automatic sensor, and the ability to clearly view the entire operation through the safety shield further add to the user-friendliness.

WORKING PRINCIPLE

Initially user will set the elastic length in measurement unit then Elastic from box is fed into twisting device that will be used to produce the neat flow of elastic to elastic feeder. Two Elastic feeders are used to avoid the elastic shrinkage problem that allows free of elastic flow. If elastic reaches the given measuring length then IR sensor sense it and send the signal to control unit. This is explained by following functional block diagram of front end, Fig.1

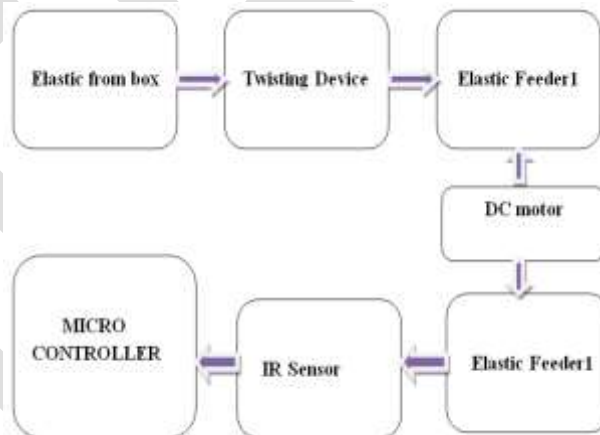

Fig .1. Functional block front end

Controller unit send the signal to Pneumatic System that uses compressed air to transmit and control energy to solenoid valve. If solenoid valve is open then the cutter device is cut the elastic once at a time, Elastic cutting information like number of elastics are cut, and elastic length are to be displayed with the help of LCD display .That can be explained by the following functional block diagram of back end, Fig.2.

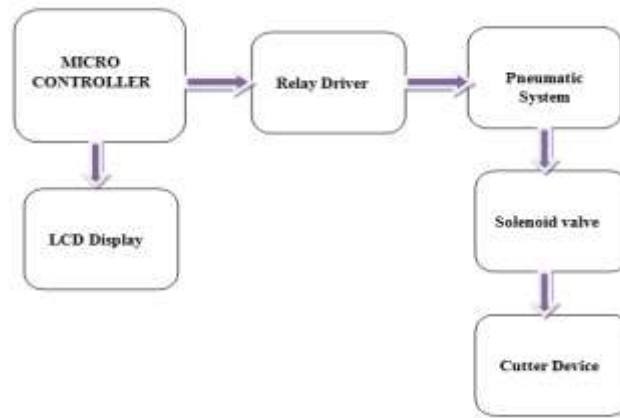

Fig.2. Functional block diagram of back end

SPECIAL FEATURES

- 1) Cutting length: 25-1000mm
- 2) Max cutting width: 80mm
- 3) Voltage, frequency: 220V/50Hz
- 4) Power: 0.22KW
- 5) High speed: It can cut 100~120 cut per minute. (50mm long)
- 6) Accuracy: Cut-length is accurate swing to a stepping motor
- 7) Cutting type: Cutting is neat due to using a cold cutter which is durable because they are made of high-speed steel.
- 8) Automatic operation: It works automatically only by setting length and quantity
- 9) Automatic stopper: It stops automatically if materials run out during operation.
- 10) Memory: Set-length, set-q'ty & set-speed are not erased even if power off & on.
- 11) Additional device: For cutting elastic band from box or ground, it prevents twisting of the band.

Entire operating function is described in the following functional flow chart Fig.3.

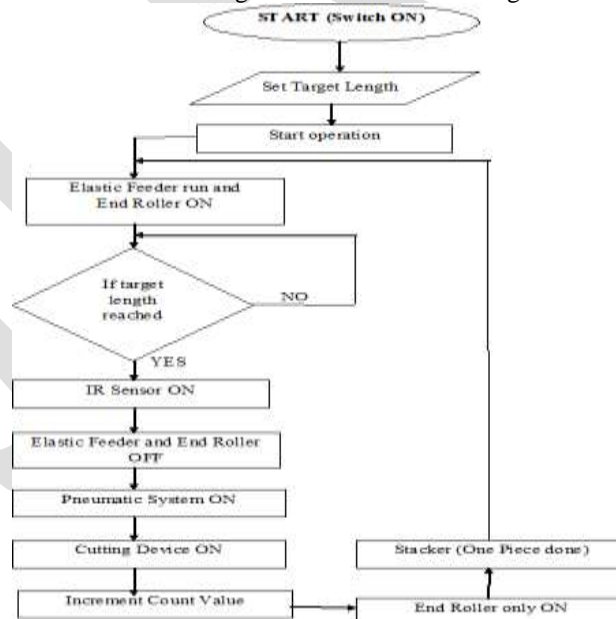

Fig.3. Functional flow chart of proposed System

APPLICATION OF PROPOSED SYSTEM

Specialized for Elastic material (rubber tape)

- ✓ Can also be used for:
- ✓ Velcro (hook & loop),
- ✓ Tape, Belt loop,
- ✓ Plastic Zipper,
- ✓ Elastic band,
- ✓ String and Shrink tube.

ADVANTAGES OF PROPOSED SYSTEM

- 1) This system is more safety to operator
- 2) Quick in response
- 3) Simple in Construction
- 4) It is very useful in all garment industries
- 5) Machine cost is low

EXPERIMENTAL RESULT

The system specifications include the software requirements for the simulation of the project. The project is simulated with the help of a desktop computer or laptop. The development tool used for the simulation of this project is Proteus 7.2 shown in Fig 4

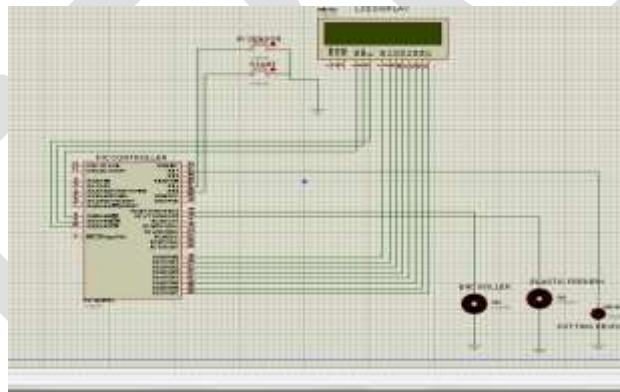

Fig.4.Simulation circuit diagram of proposed system

Press start button then the display will show "ELASTIC CUTTING MACHINE" Fig.5.

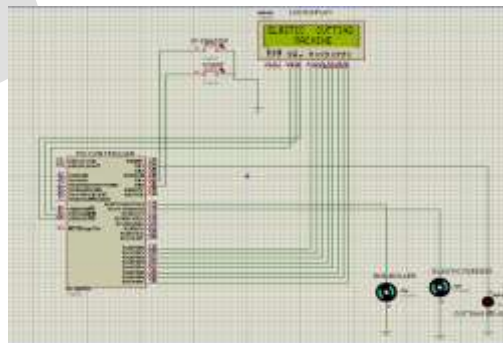

Fig.5. Switch ON the Machine

If motor will ON then rotate the Elastic feeder and End roller for elastic movement after that IR sensor is sense the elastic (given target length which was set manually as per requirement) means cutting device will ON and cut the elastic with accurate length, and also count value will be displayed shown in Fig.6.

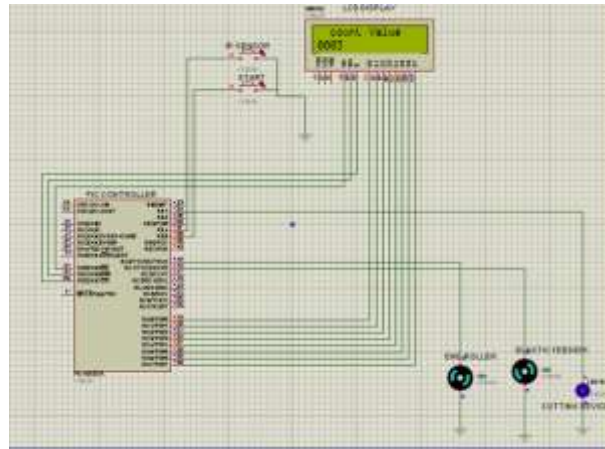

Fig.6. Elastic cut operation and display count value

Elastic feeder doesn't rotate in particular delay but End roller is continuously run to pull out the cut elastic shown in Fig.7.

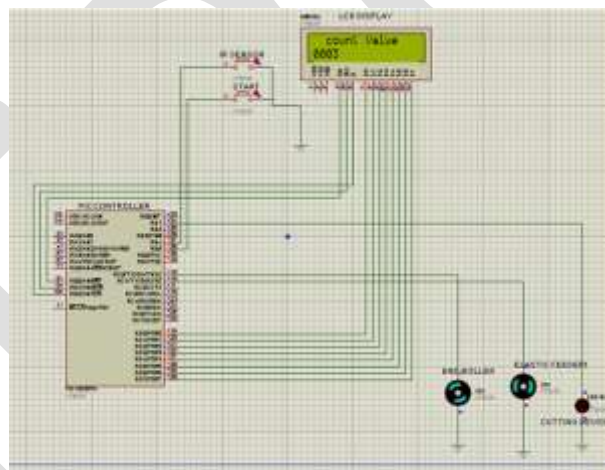

Fig.7. Elastic pullout operation end roller only ON

CONCLUSION

This proposed system provides a best cutting solution for garment technology with cheapest price. This project eliminates the disadvantages of the already existing system such as shrinkage problem and cost.

REFERENCES:

- Ana Mongal, Balwinder Singh "Finite State Machine based Vending Machine Controller with Auto-Billing Features" International Journal of VLSI design & Communication Systems (VLSICS) Vol.3, No.2, April 2012.
- Arghya Ganguly, Naveenkumar Kumbhare, Pooja Shinde, Jayashri P. Joshi "PLC based Control System for Hardening and Tempering Furnace in Heat Treatment Plant" International Journal of Advanced Research in Electrical, Electronics and Instrumentation Engineering Vol. 3, Issue 4, April 2014

- Arun S, Sree Rajendra and Vijayavithal Bongale “Automatic Punching Machine: A Low Cost Approach” International Journal of Advanced Mechanical Engineering. ISSN 2250-3234 Volume 4, Number 5 (2014), pp. 509-517
- M.Bhuvaneswari, S.Sukhumar, N.Divya, S.Kalpanadevi “Embedded System Based Automatic Ticket Vending Machine for Modern Transport System” International Journal of Advanced Research in Computer and Communication Engineering Vol. 2, Issue 11, November 2013.
- P.Keerthanaa, K.Jeevitha, V.Navina, G.Indira, S.Jayamani “Automatic Wall Painting Robot” International Journal of Innovative Research in Science, Engineering and Technology Vol. 2, Issue 7, July 2013
- Rohan Mithari , Swanand Vaze ,Sanjay Sanamdikar “Automatic Multistoried Car Parking System” International Journal Of Innovative Technology & Adaptive Management (Ijitam) Issn: 2347-3622, Volume-1, Issue-6, March, 2014.
- Samer Riachy And Malek Ghanes “A Nonlinear Controller For Pneumatic Servo Systems: Design And Experimental Tests” IEEE/ASME Transactions On Mechatronics, Vol. 19, No. 4, August 2014
- Shashank Lingappa M, Vijayavithal Bongale, Sreerajendra “PLC Controlled Low Cost Automatic Packing Machine” International Journal of Advanced Mechanical Engineering. ISSN 2250-3234 Volume 4, Number 7 (2014), pp. 803-811
- S.Ramesh , Prof. S.Yuvaraj “Improved Response Time on Safety Mechansim Based on PIR sensor” International Journal of Emerging Technology and Advanced Engineering (ISSN 2250-2459, Volume 2, Issue 4, April 2012)
- T.Kalaiselvi, R.Praveena, Aakanksha.R, Dhanya.S “ PLC Based Automatic Bottle Filling and Capping System With User Defined Volume Selection” International Journal of Emerging Technology and Advanced Engineering Website: www.ijetae.com (ISSN 2250-2459, Volume 2, Issue 8, August 2012)
- Yasar Birbir, H.Selcuk Nogay “Design And Implementation Of PLC-Based Monitoring Control System For Three-Phase Induction Motors Fed By PW Inverter” International Journal Of Systems Applications, Engineering & Development Issue 3, Volume 2, 2008