

Traveller Tracking Using Pilgrims Model in WSN

Preeti Ratnaparakhe, Prof. M. B. Tadwalkar

JSCOE Hadapsar, Pune India

preetiratn@gmail.com

Abstract— Every year millions of pilgrims gather in the small city like NASHIK for Kumbhmela, or in Amarnath or in the Holy area of Kashmir, India, to perform the rituals of GODs. Finding the position and movements of such a large number of people is important to the pilgrims themselves and the authorities managing the whole event. This paper deals a real-time pilgrim tracking or finding system that has been designed and implemented. The system relies on a dedicated delay-tolerant wireless sensor network (WSN). This WSN is interfaced to the Internet through lots of gateway(s) available from an internet service provider (ISP). Energy efficiency is most important factors in designing such system but there are few more like robustness, and reliability. Each pilgrim is given a mobile sensor unit which includes a GPS chip, a microcontroller, and antennas. A network of fixed units is installed in the Holy area for receiving and forwarding data. After a fixed period of time, each mobile unit sends its user identification (UID), latitude, longitude, and a time stamp. A central server maps the latitude and longitude information on a geographical information system (GIS). The developed system can be used to track or find a specific or a group of pilgrims.

Keywords— Kumbhmela season, pilgrim tracking, wireless sensor network (WSN).

I. INTRODUCTION

Kumbhmela or Holy area of Kashmir or Amarnath yatra or HAJJ (Pilgrimage) is the world's largest gathering of Muslims worldwide. It has unique characteristics with regards to the people who attend (pilgrims), the place they meet in, and the rituals they perform. Such a setup poses a real challenge to the authorities in managing the crowd, and tracking/identifying people. What makes it even more challenging is that all pilgrims move at the same times and to the same places. The Kumbhmela authorities control the quotas for pilgrims from each country. Yet, the number of visitors exceeds 6 million per year. This number is expected to reach 10 million in the near future. While Kumbhmela is a unique spiritual experience for all pilgrims, it poses major challenges of all sorts to the authorities responsible for facilitating this annual event. Some of the major difficulties facing pilgrims and the authorities alike include: identification of pilgrims (lost, dead, or injured), medical emergencies, guiding lost pilgrims to their respective camps, and congestion management.

For such a scenario, there is a need for a robust tracking system for pilgrims. Thus, the idea of using wireless sensor network (WSN) for tracking pilgrims was initiated [2] because passive and active RFID systems have been tested in the past with limited success (details of these experiments are discussed in [1]) and also other approaches such as image-based tracking systems are not suitable for a large crowd as in this application. Here, we propose a tracking and monitoring system that consists of small portable wireless sensor units carried by pilgrims and a fixed infrastructure of wireless network capable of gathering, processing, and routing information on locations and time stamps of the pilgrims. This paper focuses on the design, implementation and testing of a real time pilgrim tracking system. The paper is organized as follows: Section II gives the overview of literature survey of already proposed and implemented system. Section III describes the proposed design of the mobile units and the WSN. The proof of concept for the system is discussed in Section IV. Some concluding remarks are discussed in Section V.

II LITERATURE SURVEY

In wireless sensor network tracking system uses a delay/disruption tolerant design. There are mobile units as well as fixed units. This is because we have to create adhoc and fixed sensor network. The nodes in this network used to transmit and receive the data among the network. In wireless network energy efficiency is very important point because all nodes and devices are portable and they are battery backup this will be a major threat to the tracking and identification of pilgrims. Also low bandwidth is very crucial point. There are some researchers who already work on tracking of position of peoples in crowd and send the information within the network. **M. Mohandes** [3], putted the problems and difficulties facing the pilgrims and the Hajj authorities have also been on the rise - especially in crowd control and the prevention of accidents. A significant number of pilgrims die due to both accidents and natural causes, and a

large number get lost in this extremely crowded gathering. The authorities are faced with the problem of identifying the dead and injured pilgrims as well as helping those who get lost during the Hajj. In this paper, a solution based on RFID technology to help the Hajj authorities in the identification of pilgrims is developed. A pilot study is performed on 1000 pilgrims from Ivory Coast to prove the concept and get feedback on the performance. S. Mahlkecht, S.A. Madani,[4], The container trade faces a lot of challenges comprising of container tracking, real time monitoring and intrusion detection, real time theft reporting mechanism, and status reporting of shipment items. While in principle the above functionality can be provided by state of the art industrial monitoring systems, it does not provide the advantages in flexibility and cost of wireless sensor networks (WSNs). In combination with GSM and GPS/Galileo technologies, WSNs can result in a system capable of tracking and monitoring of containers in the real time. Mohamed Mohandes Digest of Technical Papers [5], developed a system for the tracking and identification of pilgrims in the Holy areas, in Makkah-Saudi Arabia, during Hajj (Pilgrimage). The area is already covered by a sophisticated 3.5G network by several service providers. Upon request or periodically, the mobile phone sends its UID, latitude, longitude, and time stamp. A server maps the latitude and longitude information on a Google map or any geographical information system. If the Internet connection is lost the mobile phone stores the location information in its memory until the Internet connection is restored, then it sends all stored location information and clears this information from memory. The developed system can be used to track a specific pilgrim. Alternatively any pilgrim can request emergency help using the same system. M. A. Haleem, C. N. Mathur, and K. P. Subbalakshmi [6], in this paper there is study of a joint distributed data compression and encryption scheme suitable for wireless sensor networks where we adopt the structured encryption system of advanced encryption standard (AES). The distributed compression is achieved as per the Slepian-Wolf coding theorem, using channel codes. Core to achieving optimal compression in the joint compression and encryption is the preservation of correlation among different blocks of data despite applying cryptographic primitives. It is established that the correlation between sources remains unchanged when cryptographic primitives, namely key addition and substitution are applied. However, as a requirement of security in the encryption, any correlation between two inputs to an encryption system is removed with diffusion techniques. Compliance to the requirements of diffusion layer of AES cipher is achieved by designing the compression function so as to maintain branch number property.

Our proposed system having some advantages over the existing system like:

- Heath monitoring is first time being implemented in the tracking system.
- Bluetooth range used in mobile is for 10 m only, but Zigbee range is 30 m and can be varied.
- Bluetooth is used for single pair, but multiple tracking is possible in our project.
- Efficient way for wireless data logging of hazardous applications.
- Less time delays and Quick response time.
- Fully automate system robust system, Low power requirement.

III. SYSTEM DESIGN

The wireless sensor network created for the pilgrim tracking system uses a delay/disruption tolerant design. There are mobile units as well as fixed units. This is because we have to create adhoc and fixed sensor network. The number of mobile units to be monitored is significantly large compared to the fixed units. The mobile units are used to capture the movement of pilgrims. Thus, the WSN for this application has similarity to the ZebraNet [3] designed for habitat monitoring. It makes use of opportunistic, ad-hoc, and short-range wireless communications to disseminate data. Ad hoc networks increase total network throughput by using all available nodes for forwarding and routing. Therefore, the more nodes that take part in packet routing, the greater is the overall bandwidth, the shorter is the routing paths, and the smaller the possibility of a network partition.

In our application, each pilgrim carries a matchbox-sized mobile unit that includes a GPS receiver and an IEEE802.16.4/ ZigBee radio to communicate with the network of fixed units. The fixed sensor units consist of hardware and software to communicate with the mobile units carried by pilgrims to make queries and to receive location and UID information. Further, these fixed units communicate with each other to route the collected data to the tracking and monitoring station via gateway nodes. The gateway nodes are part of a commercial high data rate network, such as a high speed packet access (HSPA) or any other 3.5G network. The server can receive large volume of data via this high data rate network.

The major factors considered in the design are energy efficiency and reliability. The mobile units are battery powered and therefore require energy-efficient hardware and software. This can be achieved by optimizing the data volume and signal processing to minimize energy consumption. One technique is to minimize the duty cycle (percentage of time the mobile node is on) using sleep/awake protocol. The fixed units, on the other hand, do not necessarily have strict restrictions on energy and processing power. They may, for example, draw energy from the power supply of the street lighting system. Nevertheless, their communication range is limited in a similar way to the mobile units due to regulations on emission and coexistence issues with other wireless networks in the area.

The location information of a pilgrim carrying the mobile unit along with the time stamp and UID are transmitted to the nearest fixed sensors periodically, or in response to a query originating from the monitoring station. Periodic transmission of location information facilitates continuous monitoring but leads to increased power consumption and bandwidth occupancy. Instead of periodical transmission, a mobile unit may wait to respond to a query generated by the tracking station. However, this approach may delay accessing the required information. A compromise between delay and power efficiency can be achieved by optimally selecting the interval for periodic transmission of required data. The subsections to follow elaborate on the mobile and fixed unit design, sensor network configurations, and protocols involved in the WSN based tracking system.

A. Mobile Sensor Units

The mobile units are battery powered and therefore require power-efficient hardware and software. Intuitively, the amount of signal processing and data volume to be transmitted in the mobile unit should be kept minimal. In general, there are three aspects of the nodes and the network which impact energy consumption. These are: the number of descendants in the routing

tree, radio duty cycle, and role of the node. In the designed WSN, most critical nodes in terms of energy are the mobile nodes as they are operated by small batteries. Nevertheless, the energy efficiency of the fixed nodes are also of concern. Thus, the elements of the protocols and algorithms residing in the network, MAC, and PHY layers are designed to maximize energy efficiency and limit signal interference. The components of the mobile sensor unit are shown in Fig. 1. This unit includes an off-the-shelf SiRF GPS chip capable of estimating the location information with 5 m accuracy. A microchip PIC nano Watt series microcontroller collects the data from the GPS chip and frames the same according to WSN protocol. An ISM band radio from Texas Instruments (Chipcon CC1100) transfers the location data to the fixed sensor units with a range of 50–100 m. The module also includes a ceramic chip fractal antenna for the radio, and a separate antenna for GPS receiver. Two lithium Ion AA batteries provide the power and a DC-DC converter, from Texas Instruments, conditions the battery power to 3.6 V DC.

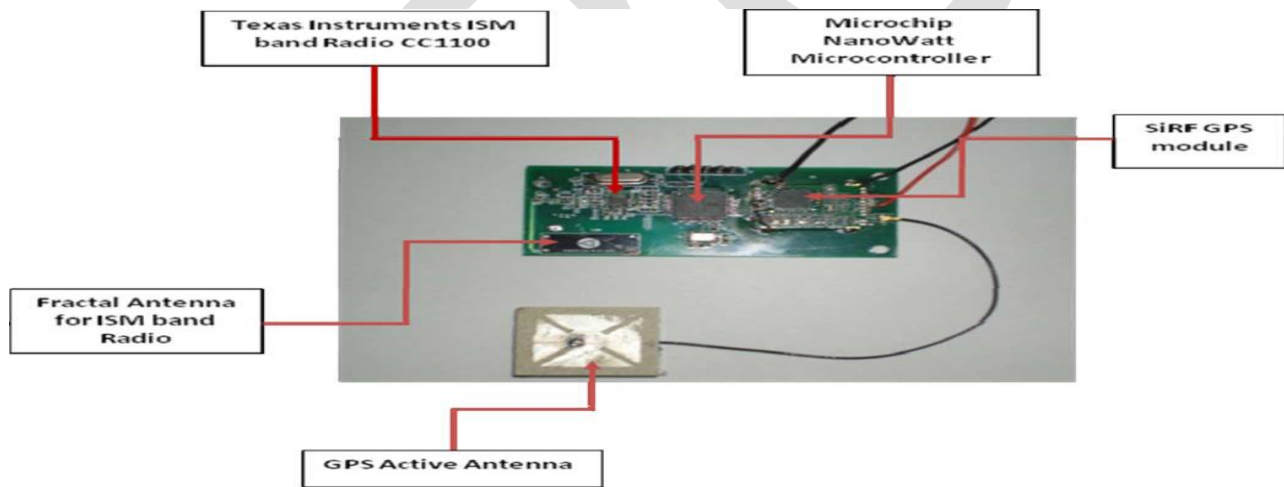

Fig. 1. Developed mobile sensor unit.

B. Fixed Sensor Units

The WSN is based on a set of fixed wireless nodes. Each fixed wireless node consists of a UHF high gain antenna, RF transceiver, microcontroller, battery and Ethernet for interfacing to the server via internet (TCP/IP connection). Whenever there is a need to locate a pilgrim, the fixed units broadcast his/her unique UID. Each mobile unit checks whether this UID matches its own. If there is a match, the mobile unit sends an acknowledgement while others remain silent. Subsequent protocol ensures that the appropriate location information is sent to the fixed node which in turn sends it to the server. To keep the overall software managing the system simple, we did not consider any data encryption at this stage since only UID (known only to authorized officers at the central server), time stamp, and location information are sent across the network.

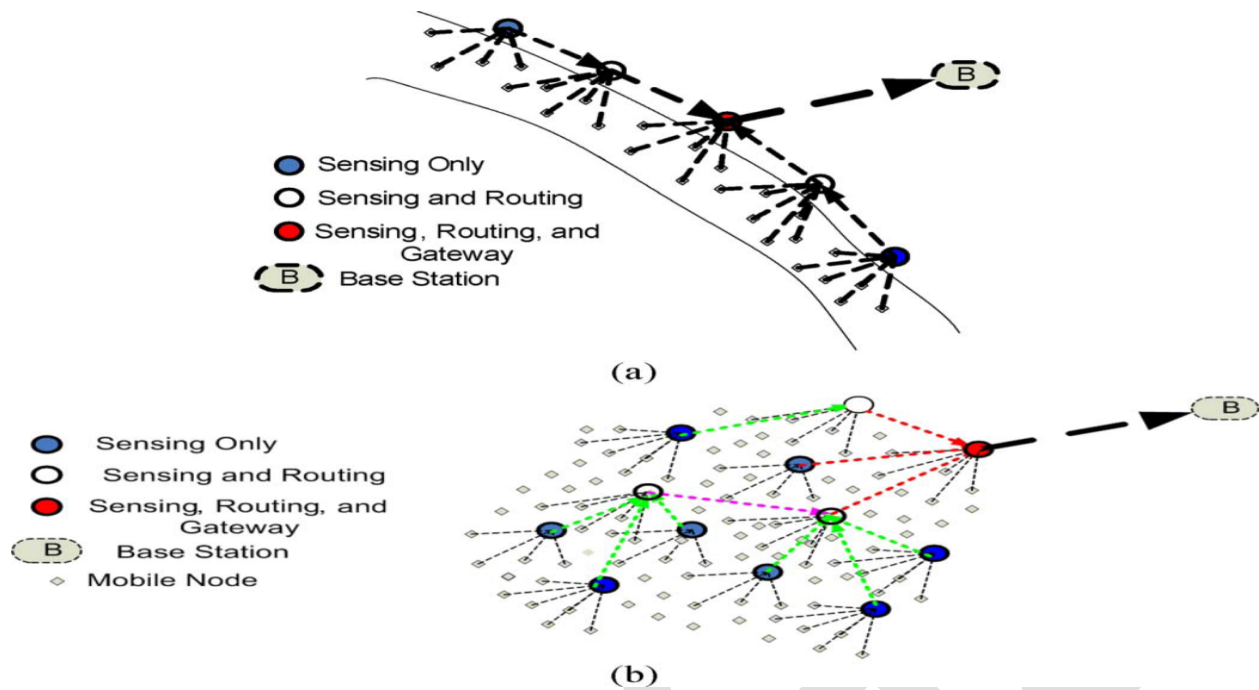

Fig. 2. (a) Sensors configuration under the pilgrim trail scenario. (b) Sensors configuration under the congregation scenario.

C. Node Configuration in the WSN

All nodes in the fixed WSN are made identical to keep the deployment, configuration and reconfiguration process simple. Under the proposed configuration, the different nodes are classified either as sensing only, sensing and routing, or gateways. Sensing-only nodes receive queries from the network; collect data from the mobile units in the vicinity, then send the data to nearby sensors. In addition to sensing, some nodes function also as routers. Moreover, few strategically placed nodes are selected to communicate with the public communication networks. Fig. 2(a) and (b) show two different deployment scenarios: long a pilgrim trail, and in a congregation.

D. Protocols and Algorithms

The minimization of energy consumptions highly relies on the processing and communication requirements of the protocols and algorithms at various layers of the WSN. Consideration of the elements at all layers with a cross layer design approach is vital to the overall efficiency of the network. At the PHY and MAC layer levels, the duty cycle of the nodes (the ratio of ON to OFF periods) is reduced by using a modified carrier-sense multiple access (CSMA) protocol. By sensing and detecting whether there is activity on the channel, a node may sleep and periodically sample the channel. If a node detects incoming energy on the channel, it stays awake to receive the packet. Because the transmitter might repeatedly send a packet, the receiver must be awake during at least one transmission of the packet—a scheme commonly called low-power listening (LPL)—inspired by ALOHA with preamble sampling. The node's duty cycle using LPL depends on the number of its neighbors, as well as the application and sensor sampling rate. Multihop communication is used to route information. Multihop communication yields reduced power consumption and scalability advantages. Under the simplest scenario, all location queries are sent by a single monitoring station. One important challenge is the design of an optimal routing protocol for sending a query to a particular pilgrim. Along with other criteria, this protocol may use prior knowledge about the location of the person being queried. Another challenge is the design of a protocol to include parallel routing of multiple queries to minimize the latency resulting from multiple queries. To simplify the complexity, the mobile units may use a flooding protocol so that a group of closest fixed sensors receive the same data. The data is stored and routed through the best multihop route to the tracking and monitoring station. The flow of commands in a typical query for a given pilgrim is outlined in Fig. 3.

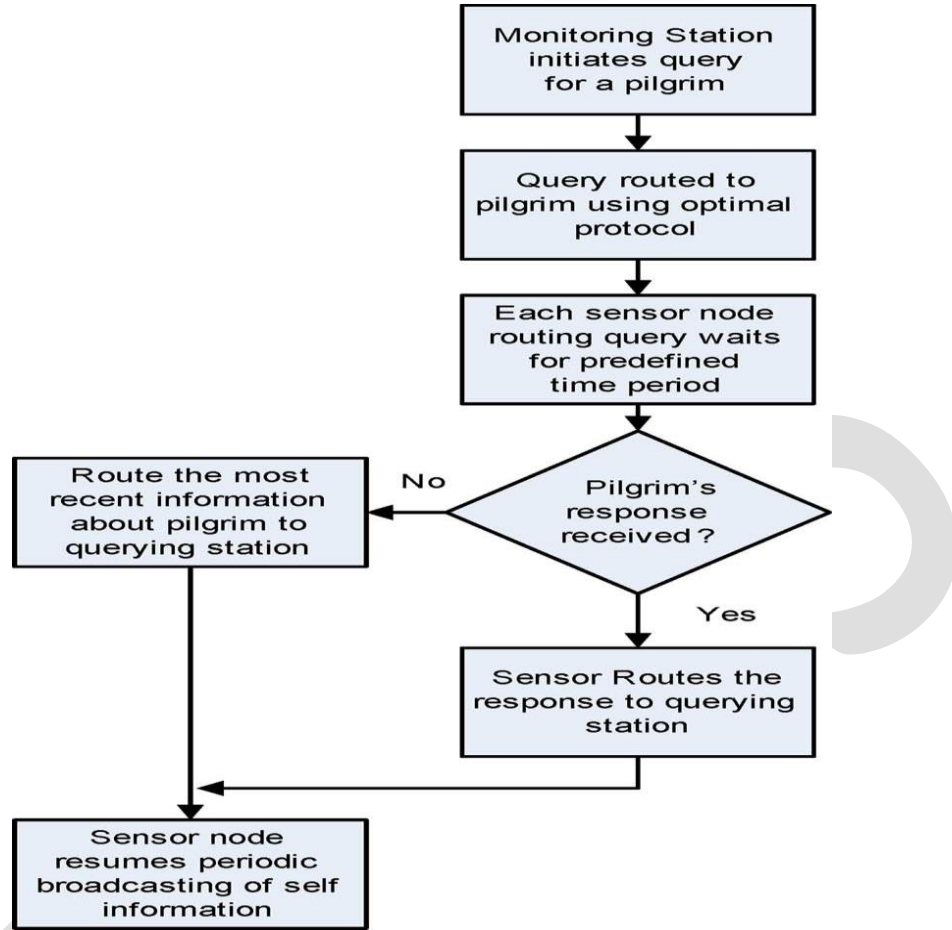

Fig. 3. Flow of commands for querying a pilgrim.

An important cost function used in the design of efficient routing protocols is discussed in [7]. For node i , this cost function is given by

$$C(\text{power}) = \varepsilon \frac{\delta_i - \sum_{j=0}^k \delta_j/k}{\sqrt{\sum_{j=0}^k \delta_j^2/k - \sum_{j=0}^k \delta_j k}}$$

Where k is the number of neighbors of node, S_i is the duty cycle of node, and S_j is the duty cycle of neighbor. The cost C is considered only if it is equal or less than the cost value of the parent node in the routing table.

The history of location information is retained and used in subsequent computations for increased energy efficiency and reduced computational load. Moreover, the use of previous location information minimizes latency in responding to future queries. Another aspect is the efficient in-network processing of data. This includes data encryption and compression. Even though we did not consider encryption at this stage, a joint data compression and encryption scheme can be used to achieve high security and good energy efficiency [8]. The benchmark standard for such implementation is the IEEE 802.15.4/ZigBee protocol suite for low bit rate communications.

IV. SCHEME DESCRIPTION

To implement the system we divided the system into two parts one is pilgrim unit and other is server unit. We have taken microcontroller ARM-7 2138. This has different units like IR sensors, LCD display, GPS, ZIGBEE, buzzer and emergency keys. The sensor senses the signals from pilgrims units which are to be tracked and has analog to digital converter of 10 bits. The pilgrim unit stores the digital data in microcontroller RAM. After this ZIGBEE is used to send the data to the desktop PC via RS232. On desktop PC we have installed VB software which is used to access data from storage.

The block diagram of pilgrim unit and server unit are shown in fig 4 and fig 5. The description of units is as follows.

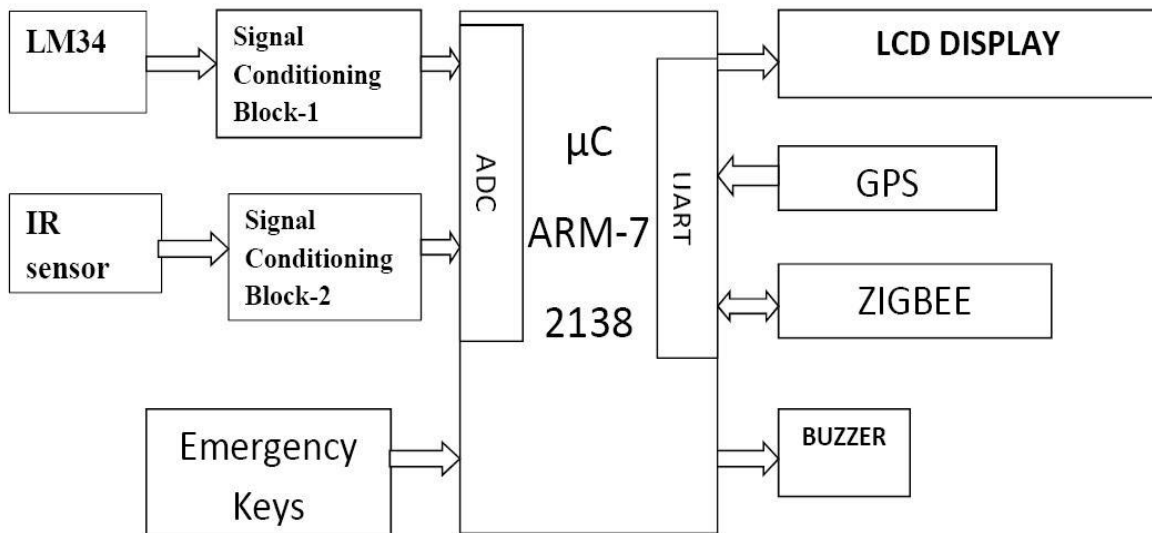

Fig 4: Block Diagram of Proposed System (Pilgrim Unit)

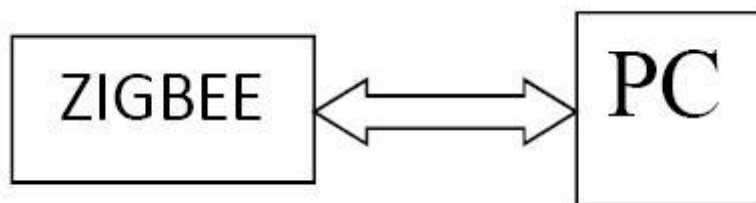

Fig 5: Server unit

A. Pilgrims Unit

The pilgrim unit is a combination of different individual parts which perform together to track the pilgrims. The sensor senses body temperature and pulse rate of the body will be sensed and counted by temperature sensor LM34 and pulse rate sensor IR obstacle sensor. The emergency keys has Keypad with 4 keys is used for emergency alertness. If the pilgrim himself will feel that something wrong is happening with him, then he can use this facility. Pilgrim where he can ask 4 predetermined questions to the base camp like-Lost, Help, water and oxygen. The buzzer is used in case of emergency. When the emergency keys are pressed the buzzer will get ON.

The signal conditioning given to sensor LM34 and IR Obstacle sensor. Signal conditioning given to sensor converts the input values compatible to the ARM7. For example if input voltage given by the sensor is 20 V but controller only needs 5V. Then signal conditioning circuit converts the voltage 20V to 5V. The LPC2138 contains two ADCs. These converters are single 10-bit successive approximation ADCs with eight multiplexed channels. ADC converts analog signal to digital signal. DAC does it vice versa.

ARM 7 is the heart of the project, which contains ADC and DAC inbuilt. It monitors the whole program given to the project. The values of health parameters will be continuously given to the LCD to display. The UART 0 and 1 which is used here is used for serial communication. It transmits and receives the data lines. It gives the data lines to the LCD, and receives the data lines from GPS. The GPS-PROGIN is used in this project. GPS receiver provides high position, velocity and time accuracy performances as well as high sensitivity and tracking capabilities. GPS finds out the location of the pilgrim. The GPS is used to log the longitude and the latitude of Pilgrim which is stored in the μ c memory. The ZIGBEE unit sends the frame to the Monitoring base CAMP containing the health parameters and the location of Pilgrim and also if any emergency then that will be communicated to server using ZIGBEE. The ZIGBEE-S1 is used for the wireless communication between pilgrim units to server unit. The data collected by ARM-7 like health parameters like body temperature and pulse rate and GPS coordinates are transferred to the PC through ZIGBEE.

B. Server Unit

In server unit VB Graphic User Interface (GUI) is used. In server unit all the location, body parameters are transferred to the PC through the ZIGBEE. In PC all the data of each pilgrim is sorted out in VB. The information of the pilgrim is stored in UID form. So the information will be kept secured.

Upon receiving the SMS, the VB s/w sorts the Pilgrim's location based on the GPS coordinates also the health status is displayed. In this way the official's can keep a track of all the Pilgrims. Here we making XBEE based network for environment application. Here we have master and slave structure for the Application. The range of XBEE is about 30 mtrs. So, the whole area cannot be covered by a single Master slave combination. For this we are covering the whole mine by a master and slave combination. We have a main PC master terminal which has the VB software on it. The PC master terminal is used to monitor the status of all the slaves which covers the whole area.

At master terminal we are receiving data from pilgrim units. In Visual Basic software we gather all data and separate it in VB software and store it in excel format. When we want to access data of all pilgrims we can generate that excel file via VB software.

Collision Avoidance protocol:

Here we are using a master Request and slave response protocol. In this system the Master sends the request to the all the slaves. In the request frame the master mentions the slave ID. The request frame is received by all the slaves who are in range. The slaves who are in range receive the incoming frame and store it in its internal RAM memory. Then they check for the slave ID. If the incoming slave ID matches with their own slave ID then they Accept the 28 frame and send the parameter back to the master. If the ID does not match then the slave discards the frame.

Cooperative communication:

Here we are using the cooperative communication technique to make sure that the slave is always in range of the master. For this we use two sub masters units. These units are basically repeater unit which will enhance the data signal when the slave is not in range of the master. Here the request is first given to the sub master. The frame transmitted by PC master will contain the sub master id as well as the slave id from whom the data is to be retrieved. The sub master upon receiving the frame will then check for the slave id and will retransmit the frame as it is. If one of the sub masters fails then the other sub master can also send the data of the other slave.

Simulation Results:

The simulation of above experiments has been taken and it exactly detects the pilgrims and tracks them in crowded area. The experiments has taken on ARM-7 which has sensing units to sense the body temperature and the data will sent in digital format to the server unit where it has processes for tracking. The figure 6 shows the simulation results.

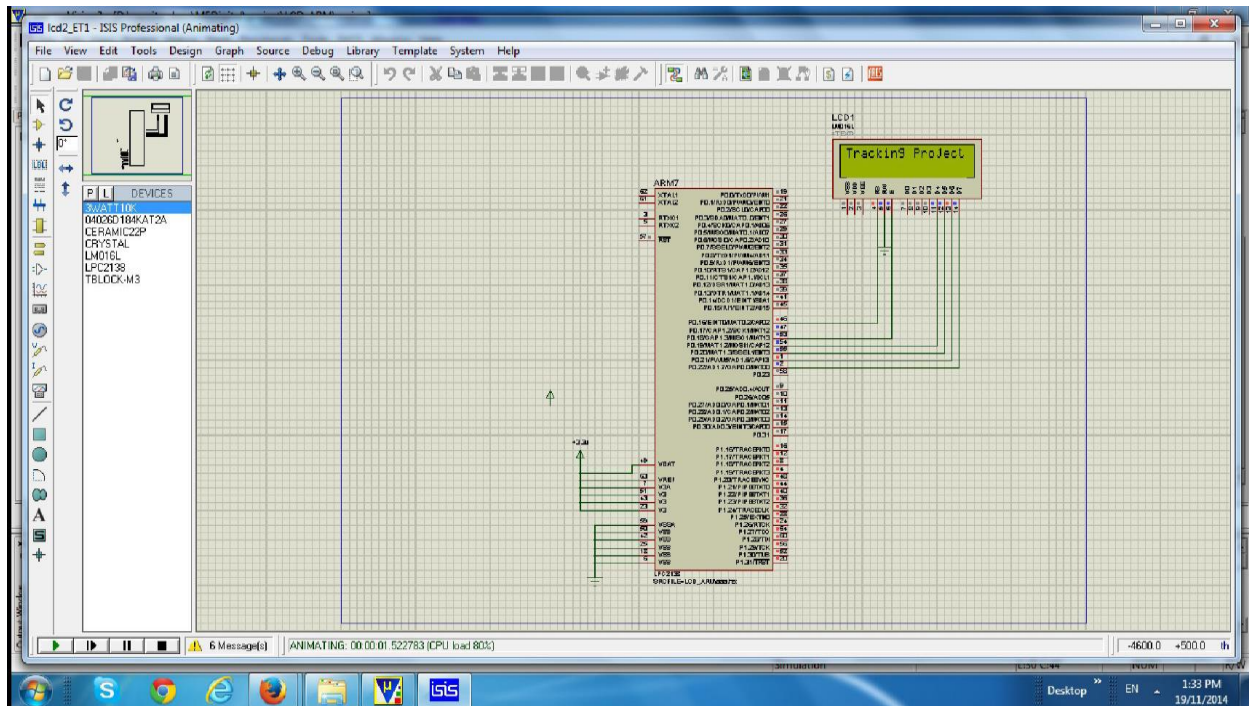

Fig:6 Simulation of LCD

In addition to tracking pilgrims, the system can also help in detecting areas with high congestion so that proper measures are taken to relieve such bottlenecks. Special software can be developed to recognize such congestions and alert authorities about these.

CONCLUSION

It is clear that the design and implementation of a system can be used for tracking and monitoring pilgrims during Amarnath, Kumbhmela season in the Holy area of Kashmir, Nashik. The system consists of mobile units carried by pilgrims and a fixed wireless sensor network. Based on some preset parameters, the WSN communicates periodically location information of pilgrims to a central server. The communication between mobile units and the WSN relies on the Zigbee protocol. The design provides an option (such as an alarm button on the mobile unit) for pilgrims to request help in case of emergency. The location information is mapped onto a GPS system for ease of localization and efficiency in providing help. It can be concluded that the system will be robust and reliable even in dense urban areas.

REFERENCES:

- [1] M. Mohandes, "RFID-based system for pilgrims identification & tracking," *J. Appl. Comput. Electromagn. Soc. (ACES)*, vol. 25, no. 3, pp. 273–282, Mar. 2010.
- [2] Mohandes, Haleem, Abul-Hussain, and Balakrishnan, "Pilgrim tracking using wireless sensor network," presented at the Workshops Int. Conf. Adv. Inform. Netw. Appl. (WAINA 2011), Singapore, Mar. 22–25, 2011.
- [3] On Architecture of Low Power Wireless Sensor Networks for Container Tracking and Monitoring Applications-S. Mahlknecht, S.A. Madani, Vol 1 Source: IEEE Xplore DOI: 10.1109/INDIN.2007.
- [4] Pilgrim tracking and identification using the mobile phone-Mohamed Mohandes Digest of Technical Papers - IEEE International Conference on Consumer Electronics 01/2011; DOI: 10.1109/ISCE.2011.5973812.
- [5] Joint Distributed Compression and Encryption of Correlated Data in Sensor Networks- M. A. Haleem, C. N. Mathur, and K. P. Subbalakshmi IEEE Military Commun. Conf. (MILCOM), Washington, DC, 2006.
- [6] P. Zhang, C. M. Sadler, S. A. Lyon, and M. Martonosi, "Hardware design experiences in zebranet," in *Proc. 2nd Int. Conf. Embed. Netw. Sensor Syst.*, New York, 2004, pp. 227–238, ACM Press.
- [7] Özdenici, B.; Aydin, M.; Coskun, V.: NFC research framework: a literature review and future research directions. The 14th International Business Information Management Association (IBIMA) Conference. Istanbul, Turkey (2010)