

# REFRACTORY FAILURE INVESTIGATION IN CFBC BOILER

1. Amol S. Kinkar 2. G. M. Dhote, 3.R. Chokkar

E-mail:amol.kinkar@gmail.com, girishdhote@gmail.com, choks.chokkar@calderys.com

**Abstract---** Heavy industrialization & modernization of society demands in increasing of power cause to research & develop new technology & efficient utilization of existing power units. Variety of sources are available for power generation such as conventional sources like thermal, hydro, nuclear and renewable sources like wind, tidal, biomass, geothermal & solar. Out of these most common & economical way for producing the power, is by thermal power stations. Various industrial boilers plays an important role to complete the power generation cycle such as CFBC (Circulating Fluidized Bed Combustion), FBC (Fluidized Bed Combustion), AFBC (Atmospheric Fluidized Bed Combustion Boiler), CO Boiler, RG & WHR Boiler (Waster heat recovery Boiler).

This paper is intended to comprehensively give an account of knowledge related to refractory & its failure in CFBC boiler with due effect of flue gas flow during operation on refractory by using latest technology of CAD (Computer aided Design) & CAE (Computer aided Engineering). By conceptual application of these technology the full scale model is able to analyze in regards the flow of flue gas & bed material flow inside the CFBC boiler via CFD (Computational Fluid Dynamics) software. The results obtained are helpful to understand the flow of flue gas & particles in different areas of boiler. Results also helped to check the velocity values in particular failure area and suggest suitable refractory material to withstand under such velocity .

**Keywords--** CFD Simulation, Cyclone Separator, CFBC loop, Refractory for CFBC Boiler, CFBC Boiler, Refractory failure in CFBC, CAD & CFD Technology.

## INTRODUCTION

On December 16, 1921 a new chapter opened in the history of the energy and power industries. Fritz Winkler of Germany introduced gaseous products of combustion into the bottom of a crucible containing coke particles, creating the first demonstration of gasification of coal in a fluidized bed. Winkler saw the mass of particles lifted by the drag of the gas to look like a boiling liquid (Squires,1983). This experiment initiated a new process called fluidization, the art of making granular solids behave like a liquid. Though some would argue that many others observed the phenomenon of fluidized beds in the past, the credit for the invention of the bubbling fluidized bed (BFB) process, which we use for scores of processes including combustion and gasification, should go to Winkler. [6]

Heavy industrialization & modernization of society demands in increasing of power cause to research & develop new technology & efficient utilization of existing power units. Fluidized bed boilers have acquired sufficient operating experience to be called a matured technology.

## LITERATURE SURVEY

The circulating fluidized bed (CFB) boiler is a member of the fluidized bed boiler family. It has gained popularity, especially in the electric power-generation market, for its several practical advantages, such as efficient operation and minimum effect on the environment. Lots of research is going on in this field to addressed different issues related to boiler operation, boiler performance, increase efficiency, and utilization of most advance tools like CFD simulation & assistance of CAD/CAE tools to addressed the combustion & flow.

Thenmozhi Ganesan, Dr. Sivakumar Lingappan [1] focused on survey on the growing energy demands in the power sector. Fluidized bed combustion (FBC) technology is continuously gaining importance due to its ability to burn different low grade coals and the absence of  $\text{NO}_x$  production.[1]

The main advantages of the fluidized bed combustion boilers are: reduced  $\text{NO}_x$ ,  $\text{SO}_x$  due to relatively low combustion temperature, better efficiency and reduction in boiler size and design. It has the ability to burn low grade coal and it is less corrosive as the combustion temperature is less when compared to that of an utility boiler. In addition to all of these, the startup and shut down operation of FBC boilers are much easier. [1]

Nan Zhang, Bona Lua, Wei Wang, Jinghai Li [2] focused on 3D CFD Simulation on Hydrodynamics of 150MW circulating fluidized bed boiler because of owing to the advantages of low emission and fuel flexibility, circulating fluidized bed (CFB) boilers for utility power generation have been increasing in the past decades in both capacity and quantity. Proper design and scale-up of a CFB boiler rely heavily on its hydrodynamic understanding. To this end, experimentation is certainly an approach, while numerical simulation is another, receiving growing interest with the rapid development of computational technologies, especially computational fluid dynamics (CFD).

Berend van Wachem, Xiao Yu and Tian-Jian Hsu [3] worked to understand the 3D Eulerian-Lagrangian Numerical Model for Sediment Transport. The motion of the sediment phase is elucidated by a Lagrangian or Discrete Element Method (DEM), implying that the individual trajectory of each particle is determined by approximating Newtons second law of motion.

Ning Yang, Wei Wang, Wei Ge, Jinghai Li[4] studied the CFD simulation to understand the two phase flow. Apart from experimental investigation, recent years have seen a rapid growth of computer simulation of gas–solid two-phase flow. Most of these simulations are based on the two-fluid approach in which gas and solid are assumed to be continuous and fully interpenetrating in each control volume, so the conservative equations of mass and momentum originally derived from single-phase flow can be extended to describe the hydrodynamics of gas–solid two-phase flow.

## CFBC TECHNOLOGY

CFBC(Figure1) i.e. Circulating Fluidized Bed Combustion is the most used & economical technology adopted by the industries. Deterioration of coal quality and pollutant gases (NO<sub>x</sub>) arising out of burning coal in conventional utility boilers lead to the development of fluidized bed combustion boilers. The main advantages of the fluidized bed combustion boilers are: reduced NO<sub>x</sub>, SO<sub>x</sub> due to relatively low combustion temperature, better efficiency and reduction in boiler size and design. It has the ability to burn low grade coal and it is less corrosive as the combustion temperature is less when compared to that of an utility boiler. In addition to all of these, the start up and shut down operation of CFBC boilers are much easier. Fluidization is the process by which the solid particles are brought to a suspended state through gas or liquid. When air or gas is passed upward through the solid particles at low velocity, they remain undisturbed. As the velocity is increased, the particles reach the state of "Fluidization".[1]

A CFBC boiler may be divided into two sections: the CFB loop and the convective or back-pass section of the boiler. The CFB loop consists of the following items making up the external solid recirculation system. (Figure 2)

1. Furnace or CFB riser
2. Gas–solid separation (cyclone)
3. Solid recycle system (loop-seal)
4. External heat exchanger (optional)

The air system is very important for the CFB boiler, as it consumes the greatest amount of power. A typical utility CFB boiler would use three types of fan/blowers:

1. Primary air fan
2. Secondary air fan
3. Loop-seal air fan or blower

The primary air fan delivers air at high pressure (10 to 20 kPa). This air is preheated in the air preheater of the boiler and then enters the furnace through the air distributor grate at the bottom of the furnace.

The secondary air fan delivers air, also preheated in the air preheater, at a relatively low pressure (5 to 15 kPa). It is then injected into the bed through a series of ports located around the periphery of the furnace and at a height above the lower tapered section of the bed. In some boilers, the secondary air provides air to the start-up burner as well as to the tertiary air at a still higher level, if needed. The secondary air fan may also provide air to the fuel feeder to facilitate the smooth flow of fuel into the furnace.

Loop-seal blowers deliver the smallest quantity of air but at the highest pressure. This air directly enters the loop-seals through air distribution grids. Unlike primary and secondary air, the loop-seal air is not heated. [6]

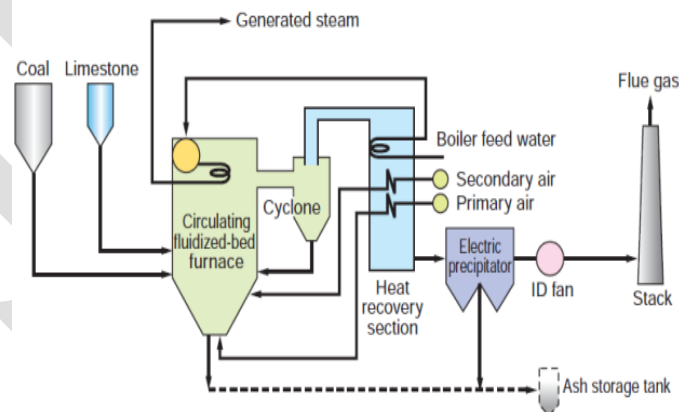

Figure 1.CFBC Boiler General Arrangement

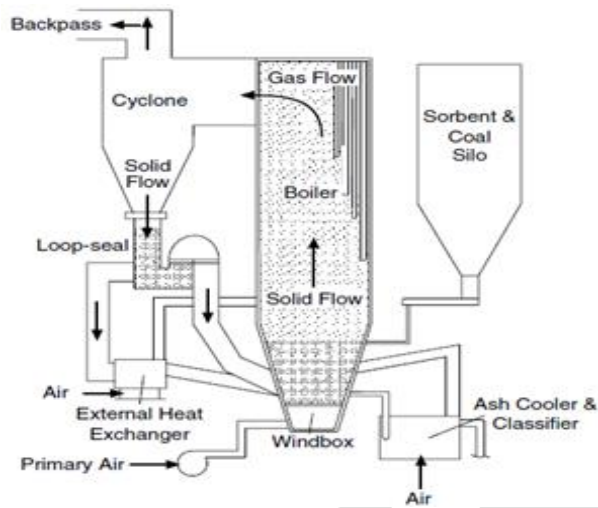

Figure 2.CFBC Boiler Component

## REFRACTORY

Refractories are heat-resistant materials that constitute the linings for high-temperature furnaces and reactors and other processing units. In addition to being resistant to thermal stress and other physical phenomena induced by heat, refractories must also withstand physical wear and corrosion by chemical agents. Refractories are more heat resistant than metals and are required for heating applications above 1000°F (538°C).

The term refractory refers to a substance that is hard to fuse, while insulation refers to a substance with a high thermal resistance. Both are used as inner linings of gasifiers, furnaces, combustors, or hot ducts. These two play a critical role in modern FBC because they protect the internals from hot abrasive particles and gases moving at high velocities. The reliability of the refractory and insulation linings is dependent upon the successful combination of materials, proper design, and installation of the refractory. [6]

### Importance of refractory

The inner lining of a furnace or hot duct serves two purposes: protection against erosion and protection against high temperatures. Refractory serves the first purpose and insulation serves the second.

- Erosion Resistance

Erosion resistance is a critical criterion for refractory selection. Potential for severe erosion in the cyclones and transfer lines requires that special erosion-resistant materials be used in these areas. ASTM test C-704 is a commonly-used procedure for evaluating the relative erosion resistance of refractory materials.

- Insulating Surfaces

Another important feature of the lining is to insulate against heat loss in areas where heat cannot be transferred to the water wall tubes. [6]

### Properties of refractory

Principal qualities required in a refractory material are (BEI, 1992a, 1992b):

- Resistance to the temperatures to which it is likely to be exposed
- Resistance to any stress likely to be imposed by adjacent material
- Resistance to any vibrations and mechanical blows that may occur
- Resistance to the slagging action of the fuel
- Uniform expansion and contraction properties
- Resistance to environmental attack associated with oxidizing or reducing conditions

Important physical properties of the materials selected for the lining include erosion resistance, thermal conductivity, volume stability, and thermal expansion/shrinkage.

## PROBLEM IDENTIFICATION

Fluidized bed boilers have acquired sufficient operating experience to be called a matured technology. Innovative modifications of different components of the boilers largely addressed the problems affecting materials and performance. Still, some problems remain, forcing occasional shutdowns. Most forced outages or shutdowns of a boiler are related to materials, operation, or design issues. Some

fluidized bed boilers of older design have experienced availability as low as 70% due to failures of their refractory parts or erosion of pressure and non pressure parts. Failure of a critical component results in shutdown of the entire power plant and requires immediate attention, making material issues the most immediate concern for the plant operators. Thus, a good selection of materials and the understanding of their behavior in a fluidized bed environment are critical to the operators.

Erosion resistance is a critical criterion for refractory selection. Potential for severe erosion in the cyclones and transfer lines requires that special erosion-resistant materials be used in these areas.

The most common areas of refractory erosion & failure are Cyclone, Cyclone inlet Duct & Loop Seal. The combustor roof and cyclone inlet are subjected to impact by high-velocity flue gases containing large particle clusters at high temperatures (800 to 900°C). Both gas and bed materials change direction here, and thereby cause greater impact on the wall. The thickness of the total lining varies from 300 to 400 mm. In the cyclone inlet, a dense-phase castable is used on the hot face along with one or two layers of insulating material.

The cyclone wall of a CFB boiler experiences the most severe conditions. Thermal cycling is rather common as the temperature varies between 850 and 950°C with little change in operating parameters. For this region, a dense-phase refractory along with an insulating back-up of 400 to 500 mm is used. Generally, a multilayer brick lining with a calcium silicate block next to the shell, followed by insulating firebrick and a hot face of dense, abrasion-resistant, superduty or mullite brick is used to resist the erosion of the refractory lining. (Figure 3.) [6]

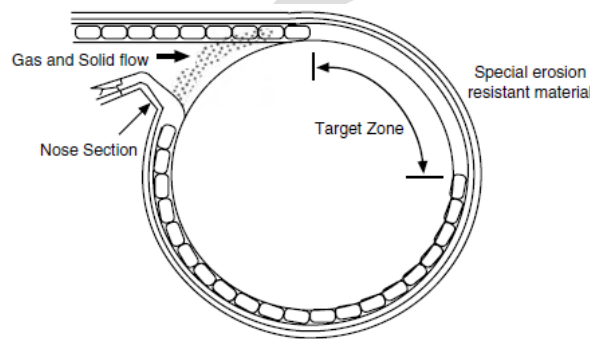

Figure 3. Cyclone Target Area

Actual photographs for the target zone, cyclone cylinder, & bottom cone shows the erosion & failure of refractory. (Figure 4 to Figure 6)



Figure 4. Photograph of Erosion in Cyclone Target Area

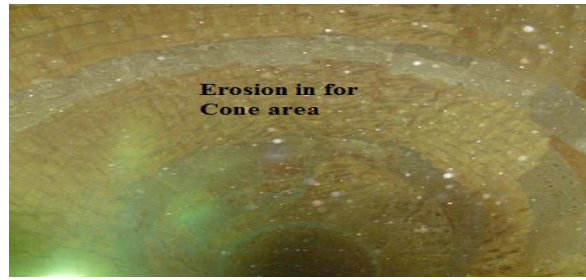

Figure 5. Photograph of Erosion for Cyclone Cone

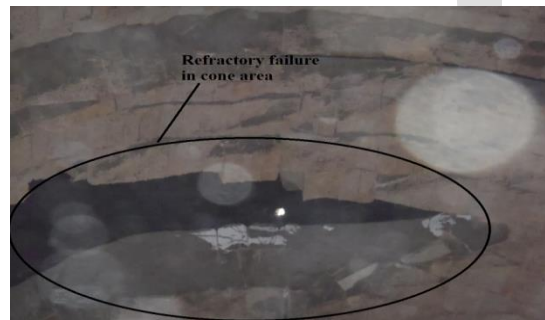

Figure 6. Photograph of Refractory Failure in Cyclone Cone

### AIM AND OBJECTIVE

Most uncertain & unplanned activity due to failure of refractory is the shutdown of boiler operation. To bring back boiler into operation is cumbersome activity. So it is always advisable to avoid the unplanned shutdowns. Aim & objective is to understand the cause of failure & serve the solution with technical aspects. This can be only achieved by using advance CAD/CAE/CFD tools available to demonstrate the actual boiler operation phenomenon virtually in to computers. Steps followed to achieve the simulation are

- Prepare individual equipments into CAD software
- Prepare the general arrangement of equipments of CFBC boiler
- To simulate the flow of flue gas inside the loop of CFBC boiler by using CFD software to understand & address the failures

### A. INPUT FOR MODELING & SIMULATION

The process parameters for the CFBC operation are listed here taken as a reference from 1X120 T/H, 64 kg/cm<sup>2</sup> (g), 485± 5° C to conduct CFD study. The flue gas of 1.3128 Kg/Nm<sup>3</sup> density flows with rate of 113350 Nm<sup>3</sup>/hr along with maximum size of coal is 6mm. The weather condition where the operation conducted is as ambient temperature 30<sup>0</sup> C with 80% relative humidity. The operating data is as given in following Tables (Table 1 to 5).

Table 1: Atmospheric condition

Sr. No	Atmospheric Conditions		
	Description	Design	Range
1	Ambient temperature (C)	30	24 - 40
2	Relative humidity (%)	80	40 - 100
3	Elevation above MLS (m)	31	
4	Seismic zone as per IS 1894	Zone IV	
5	Max. wind velocity (m/s)	40	



Table 2: Fluidized Bed Area

Sr. No	Operating Conditions		
	Description	Unit	Values
1	Operating temperature	°C	850±50
2	Operating Pressure	mbar	200
3	Excess air Coeff.	-	0.49 to 1
4	Gas Velocity Max.	m/s	6.0
5	Particle Loading	Kg/nm <sup>3</sup>	Dense fluidized bed (1000 to 1500)

Table 3: Cyclone inlet & roof

Sr. No	Operating Conditions		
	Description	Unit	Values
1	Operating temperature	°C	850±50
2	Operating Pressure	mbar	0 to 100
3	Excess air Coeff.	-	0.73 to 1.2
4	Gas Velocity Max.	m/s	7.0
5	Particle Loading	Kg/nm <sup>3</sup>	20

Table 4: Ducting System

Sr. No	Operating Conditions		
	Description	Unit	Values
1	Operating temperature	°C	900±50
2	Operating Pressure	mbar	-10 to 20
3	Excess air Coeff.	-	1.2
4	Gas Velocity Max.	m/s	28
5	Particle Loading	Kg/nm <sup>3</sup>	15

Table 5: Cyclone

Sr. No	Operating Conditions		
	Description	Unit	Values
1	Operating temperature	°C	950±50
2	Operating Pressure	mbar	-25 to +40
3	Excess air Coeff.	-	1.2
4	Gas Velocity Max.	m/s	6.0 - 28
5	Particle Loading	Kg/nm <sup>3</sup>	1 - 15

With above input along with the dimensional inputs 3D models were prepared into CAD system (Figure 7). In later stage this model is used for meshing purpose. The method used for the meshing is the block structure meshing in ICEM CFD software (Figure 8 & Figure 9). Various meshing techniques are available so depending upon the complexity of equipment the meshing method needs to be change. While simple ducts can be modelled using a single block, majority of the geometries encountered in real life have to be modelled using multi-block strategies if at all it is possible.

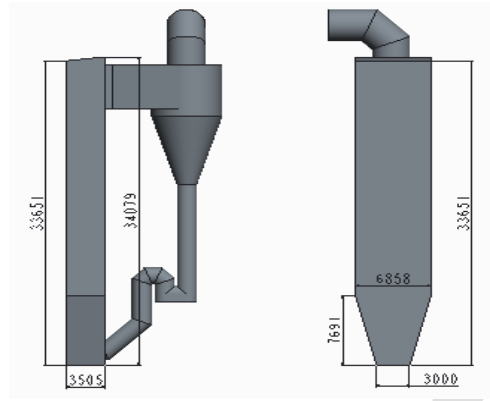

Figure 7. 3D model with actual dimensions

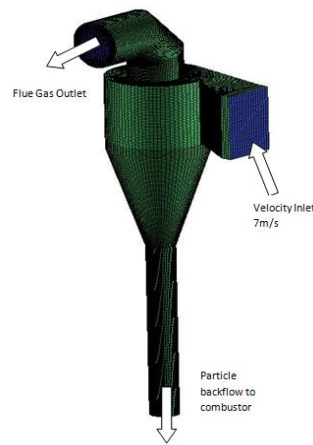

Figure 8. Meshed model with O-Grid Method

No. of Nodes - 715023  
No. of Elements - 697832

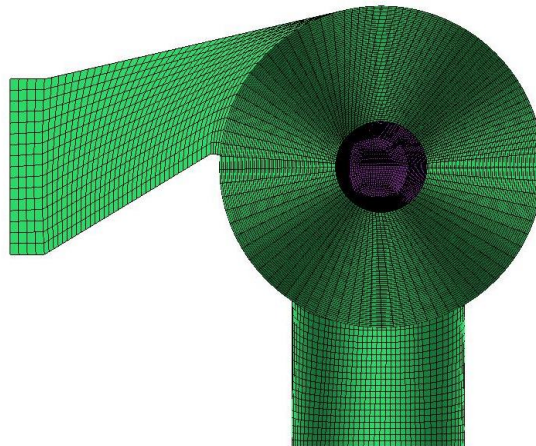

Figure 9. Meshed model-View from top

## CFD SIMULATION

Ron Zevenhoven, Mika Järvinen studied the versatility and power of commercial CFD software codes that are readily available on the open market has resulted in their widespread and straightforward use in industrial equipment design. R&D institutes and academia, however, typically operate outside the range of possibilities offered by these products and are often involved in improving or developing certain sub-models. This certainly holds for CFB reactors involving a complex situation of multi-phase flow and chemistry. For CFB combustion or gasification reactors homogeneous (gas phase) as well as heterogeneous (gas/solid) turbulence/chemistry interactions must be considered. Aiming at CFD-based modelling of CFB reactors a round-robin was made over several commercial CFD codes considering their use in multi-phase flow system calculations.[5]

Based on various research papers available on the CFD study for reactor & processing equipments & available help manuals from ANSYS, Menter SST K-Omega model is selected to ensure resolving the flow gradients that are expected in the Cyclone Separator. The shear-stress transport (SST)  $k-\omega$  model was developed by Menter to effectively blend the robust and accurate formulation of the  $k-\omega$  model in the near-wall region with the free-stream independence of the  $k-\epsilon$  model in the far field. To achieve this, the  $k-\epsilon$  model is converted into a  $k-\omega$  formulation. The SST  $k-\omega$  model is similar to the standard  $k-\omega$  model, but includes the following refinements:

- The standard  $k-\omega$  model and the transformed  $k-\epsilon$  model are both multiplied by a blending function and both models are added together. The blending function is designed to be one in the near-wall region, which activates the standard  $k-\omega$  model, and zero away from the surface, which activates the transformed  $k-\epsilon$  model.
- The SST model incorporates a damped cross-diffusion derivative term in the  $\omega$  equation.
- The definition of the turbulent viscosity is modified to account for the transport of the turbulent shear stress.
- The modeling constants are different.

These features make the SST  $k-\omega$  model more accurate and reliable for a wider class of flows (e.g., adverse pressure gradient flows, airfoils, transonic shock waves) than the standard  $k-\omega$  model. Other modifications include the addition of a cross-diffusion term in the  $\omega$  equation and a blending function to ensure that the model equations behave appropriately in both the near-wall and far-field zones.

## Acknowledgment

The author would like to thanks to Dept. General Manager of CALDERYS INDIA REFRACTORY LTD. India, for continuous support & assistance related to the work.

## RESULT & CONCLUSION

CFD simulation study has been conducted on full scale model to understand the behaviour & flow of flue gases inside the CFBC boiler equipments like cyclone, return leg & cyclone outlet duct. The model is setup & solved using ICEM CFD (ANSYS) software. The model was converged (Fig 10) & results for Velocity & Vorticity were (Fig 11 & 12) obtained. The results from CFD were compared with given data from the processing equipment supplier & found within acceptable limits.

From Velocity plot it is observed that the velocity goes in Cyclone up to 30m/s for some area. Installed refractory for this area was as per the technical requirement from end user which do not commit the expected life for the boiler hence needs to be replaced. The results also help to understand the flow of flue gases in the cyclone separator & actual target velocities which is practically difficult to get from the operating boiler. From vorticity plot (Fig 12-Section 3) it is observed that the vortex is focused in one direction which can be one prominent cause of refractory failure in cyclone cone (Fig 6).

Research is going in the direction of preparation of mathematical model for predicting wear phenomenon which may compare the results from the CFD along with the mathematical model. Results can be more furnished by applying different CFD codes to the model which helps to compare the outcomes.

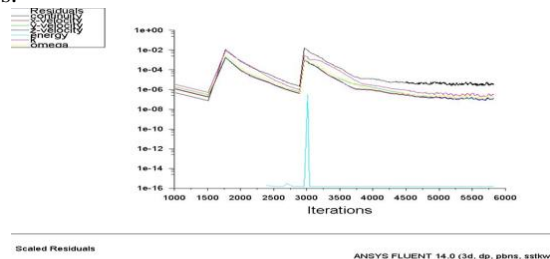

Figure 10. Convergence Graph



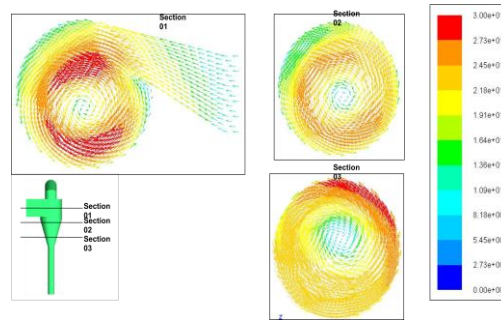

Figure 11. Velocity magnitude for Cyclone Separator

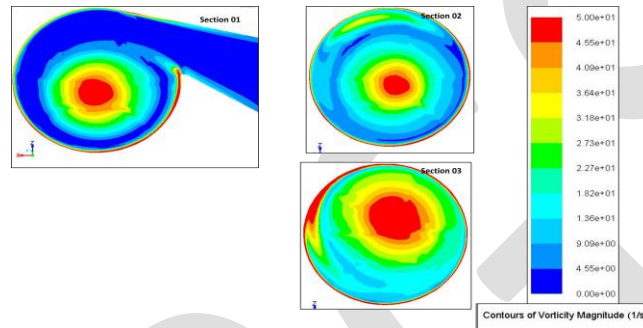

Figure 12. Vorticity magnitude for Cyclone Separator

#### REFERENCES:

1. Thenmozhi Ganesan, Dr.Sivakumar Lingappan," A Survey on Circulating Fluidized Bed Combustion Boilers", International Journal of Advanced Research in Electrical, Electronics and Instrumentation Engineering, Vol. 2, Issue 8, August 2013, ISSN (Print) : 2320 – 3765, ISSN (Online): 2278 – 8875
2. Nan Zhang, Bona Lu, Wei Wang, Jinghai Li ,"3D CFD simulation of hydrodynamics of a 150MWe circulating fluidized bed boiler", Chemical Engineering Journal ,162 (2010) 821–828
3. Berend van Wachem, Xiao Yu and Tian-Jian Hsu,"A 3D Eulerian-Lagrangian Numerical Model for Sediment Transport", 7th Int. Conf. on Multiphase Flow (ICMF-2010) Tampa (FL) USA, May30-June4-2010
4. Ning Yang, Wei Wang, Wei Ge, Jinghai Li ,"CFD simulation of concurrent-up gas–solid flow in circulating fluidized beds with structure-dependent drag coefficient", Chemical Engineering Journal,96 (2003) 71–80
5. Ron Zevenhoven, Mika Järvinen, "CFB reactors, CFD and particle/turbulence interactions " , 4th Int. Conf. on Multiphase Flow (ICMF-2001) New Orleans (LA) USA, May 27 - June 1, 2001,Zevenhoven & Järvinen, # 727 / 1
6. Professor Prabir Basu," Combustion and gasification in fluidized bed", CRC Press, Taylor & Francis Group-2006,ISBN-1978-0-8493-3396-5,Pg No-1-20,253-265,299-335