

# Simplified views of a complex 3-Dimensional object in 2-Dimensional technical drawing for image processing

Deepa Mittal<sup>1</sup>, Manoj mittal<sup>2</sup>, Dr. P. K. Jamwal<sup>3</sup>

<sup>1</sup>Research Scholar, Computer Engineering Pacific Academy of Higher Education and Research University Udaipur, Udaipur,

<sup>2</sup>Asst. Prof. Mechanical Engineering Department, Govt. Engg. College Jhalawar, Jhalawar,

<sup>3</sup>Professor, Mechanical Engineering Dept. Rajasthan Technical University Kota, Kota, India

**Abstract-** Drawing is to be considered as universal language. Drafting is a technical drawing<sup>5</sup> used by designers to graphically present ideas and represent objects necessary for a designed environment. A set of this drafted illustration is called a construction document. There are common rules and standards to ensure that all designers are able to understand what is in the drawing. These design drawings use a graphic language to communicate each & every piece of information necessary to convey an idea and ultimately create a design. The basic principle of the Technical drawing is the representation of a three-dimensional body (usually it is a component or assembly) in a two-dimensional drawing. To the uniqueness of the drawing to realize in various views (e.g. from the front, from the side and rear). Complex components may require that the carcasses of several pages (ie, multiple views) must constitute representations or even cut through the component must draw round. In this paper we will show the representation of technical drawing in the standard view.

**Keywords :** technical drawing, assembly, complex components, carcasses, construction document, multiple views, three dimensional body.

## INTRODUCTION

An engineering drawing is a legal document (that is, a legal instrument), because it communicates all the needed information about "what is wanted" to the people who will expend resources turning the idea into a reality. Industry requires many millions of drawings every year. Every part must have a working drawing. These drawings communicate the details to a skilled craftswoman or man so the item can be correctly manufactured<sup>10</sup>. Engineering drawings specify requirements of a component or assembly which can be complicated. Standards provide rules for their specification and interpretation. Drawings convey the following critical information:

- Geometry – the shape of the object, represented as views, how the object will look when it is viewed from various angles, such as front, top, side, etc.
- Dimensions – the size of the object is captured in accepted units.
- Tolerances – the allowable variations for each dimension.
- Material – represents what the item is made of.
- Finish – specifies the surface quality of the item, functional or cosmetic. For example, a mass-marketed product usually requires a much higher surface quality than, say, a component that goes inside industrial machinery.

### 1. Sets of technical drawings

#### **Working drawings**

Working drawings are the set of technical drawings used during the manufacturing phase of a product. In architecture<sup>8,11</sup>, these include civil drawings, architectural drawings, structural drawings, mechanical systems drawings, electrical drawings, and plumbing drawings.

## ***Assembly drawings***

Assembly drawings show how different parts go together, identify those parts by number, and have a parts list, often referred to as a bill of materials. In a technical service manual, this type of drawing may be referred to as an exploded view drawing or diagram, we can use these parts in engineering.

## ***As-fitted drawings***

These are also called As-Built drawings, or As-made drawings. As-fitted drawings represent a record of the completed works, literally 'as fitted'. These are based upon the working drawings and updated to reflect any changes or alterations undertaken during construction or manufacture.

### ***2. Types of technical drawings***

The two types of technical drawings are based on graphical projection. This is used to create an image of a three-dimensional object onto a two-dimensional surface.

## ***Two-dimensional representation***

Two-dimensional representation uses orthographic projection to create an image where only two of the three dimensions of the object are seen.

## ***Three-dimensional representation***

In a three-dimensional representation, also referred to as a pictorial, all three dimensions of an object are visible.

Difference between 2D & 3D drawing:

A 2D drawing is a flat drawing that focuses on balance and symmetry, while a 3D drawing focuses on depth and space. Standard 2D art focuses on the contrast, rhythm, scale and proportion of a drawing, whereas 3D art looks at the depth and sculpture of the drawing. Examples of 2D art are graphic design, digital imaging and fabric design. Examples of 3D art include animation, sculpting and metal work. The visual contrast between the two types of drawings is a 2D drawing is a flat drawing and a 3D drawing looks like it has jumped off the page.

**3. Different types of view :** In most cases, a single view is not sufficient to show all necessary features, and several views are used. Types of views include the following:

### **3.1 Orthographic projection**

Orthographic Projection<sup>2</sup> is a way of visualizing different views of an object from these different sides such as a top view, front view, side view, the object is rotated so that the viewer viewing the object can see each individual side as the part is rotated. These Views are then drawn on a sheet of paper, enough views are drawn of the object to Help the person manufacturing the part to get a good visualization of what the part looks Like. The most common views drawn of an object in an orthographic drawing are the front view, top view, and right side view. After the views have been drawn on a sheet of paper notes and dimensions are then added. In orthographic projection there are 6 principle views of an object, front, top, L side, R side, rear, and back views. The three most commonly views drawn on a technical drawing are the front, back, and side views most other views are not needed. Other views may be needed in order for the person who is creating the Part, to better visualize it in order to properly manufacture it. The orthographic projection shows the object as it looks from the front, right, left, top, bottom, or back, and are typically positioned relative to each other according to the rules of either first-angle or third-angle projection. The origin and vector direction of the projectors (also called projection lines) differs, as explained below. In first-angle projection, the projectors originate as if radiated from a viewer's eyeballs and shoot through the 3D object to project a 2D image onto the plane behind it. The 3D object is projected into 2D "paper" space as if you were looking at a radiograph of the object: the top view is under the front view, the right view is at the left of the front view. First-angle projection is the ISO standard and is primarily used in Europe. In third-angle projection<sup>3</sup>, the projectors originate as if radiated from the 3D object itself and shoot away from the 3D object to project a 2D image onto the plane in front of it. The views of the 3D object are like the panels of a box that envelopes the object, and the panels pivot as they open up flat into the plane of the drawing. Thus the left view is placed on the left and the top view on the top; and the features closest to the front of the 3D object will appear closest to the front view in the drawing. Third-angle projection is primarily used in the United States and Canada, where it is the default projection system according to ASME standard ASME Y14.3M.

## First and Third Angle Projections

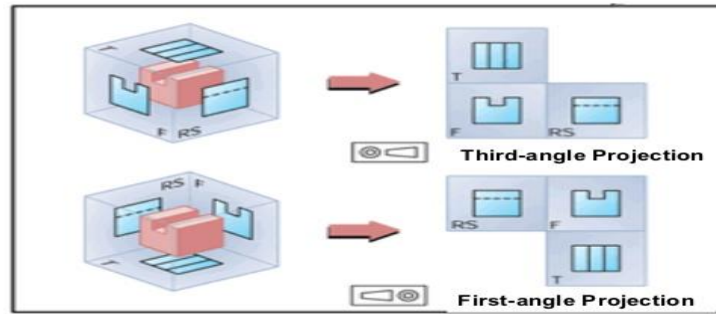

- First Angle
- Third Angle

Fig. 3.1 1<sup>st</sup> angle & 3<sup>rd</sup> angle view.

As shown above, the determination of what surface constitutes the front, back, top, and bottom varies depending on the projection method used.

Not all views are necessarily used. Generally only as many views are used as are necessary to convey all needed information clearly and economically. The front, top, and right-side views are commonly considered the core group of views included by default, but any combination of views may be used depending on the needs of the particular design.

### 3.2 Auxiliary projection

An auxiliary view<sup>1</sup> is an orthographic view that is projected into any plane other than one of the six principal views. These views are typically used when an object contains some sort of inclined plane. The auxiliary view allows for that inclined plane (and any other significant features) to be projected in their true size and shape. The true size and shape of any feature in an engineering drawing can only be known when the Line of Sight (LOS) is perpendicular to the plane being referenced. It is shown like a three-dimensional object.

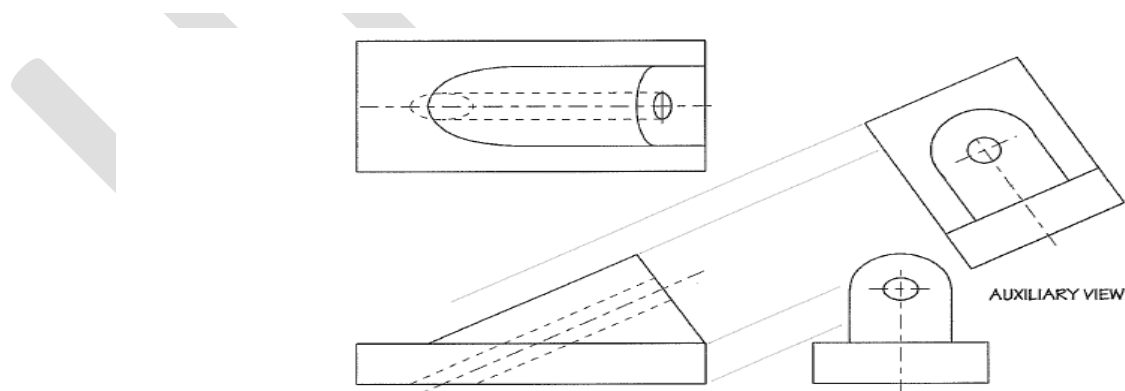

Fig 3.2 auxiliary projection.

### 3.3 Axonometric projection

It is a type of parallel projection used for creating a pictorial drawing of an object, where the object is rotated along one or more of its axes relative to the plane of projection. There are three main types of axonometric projection: isometric, dimetric, and trimetric projection.

#### 3.3.1 Isometric projection

The isometric projection<sup>4</sup> show the object from angles in which the scales along each axis of the object are equal. Isometric projection corresponds to rotation of the object by  $\pm 45^\circ$  about the vertical axis, followed by rotation of approximately  $\pm 35.264^\circ$  [=  $\arcsin(\tan(30^\circ))$ ] about the horizontal axis starting from an orthographic projection view. "Isometric" comes from the Greek for "same measure". One of the things that makes isometric drawings so attractive is the ease with which 60 degree angles can be constructed with only a compass and straightedge.

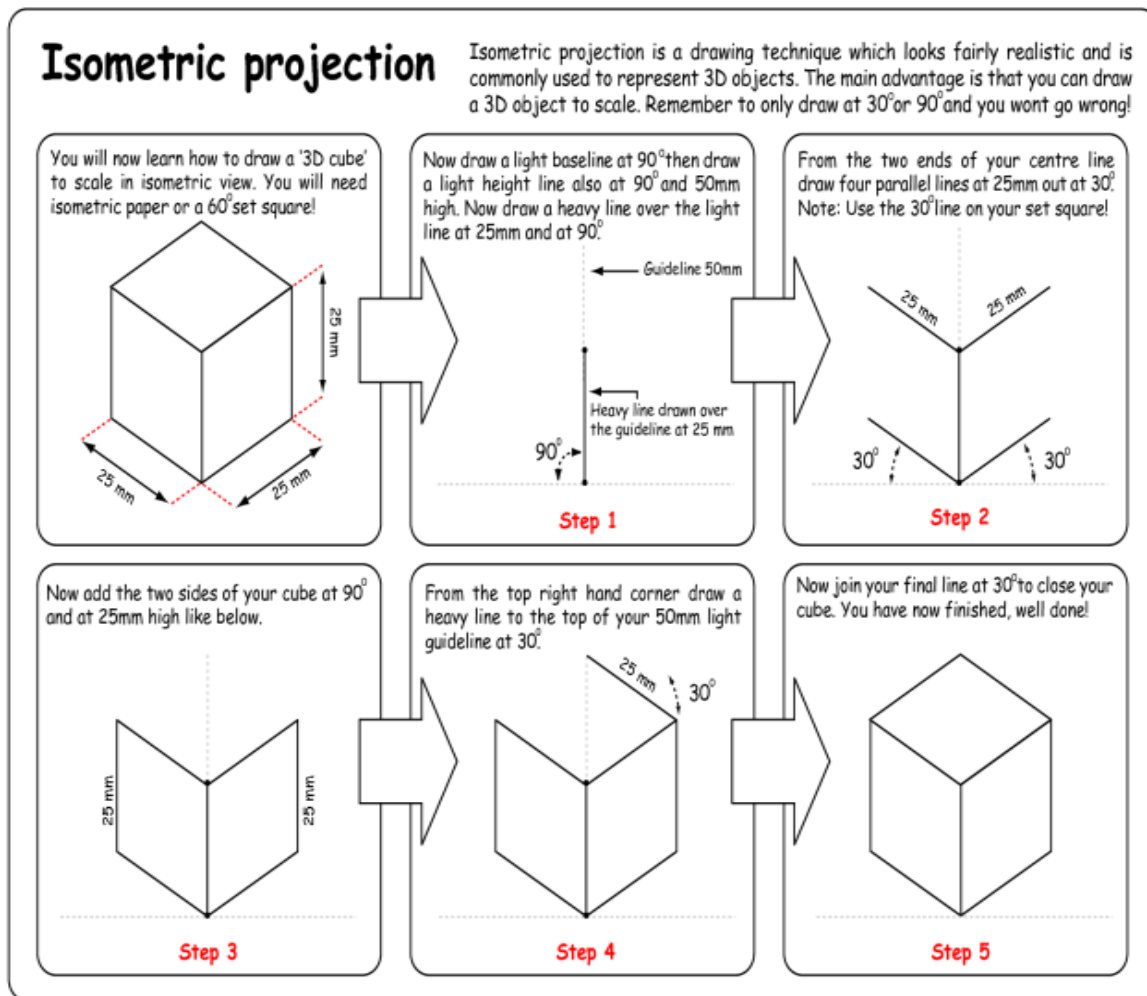

Fig. 3.3.1 steps for drawing isometric view.

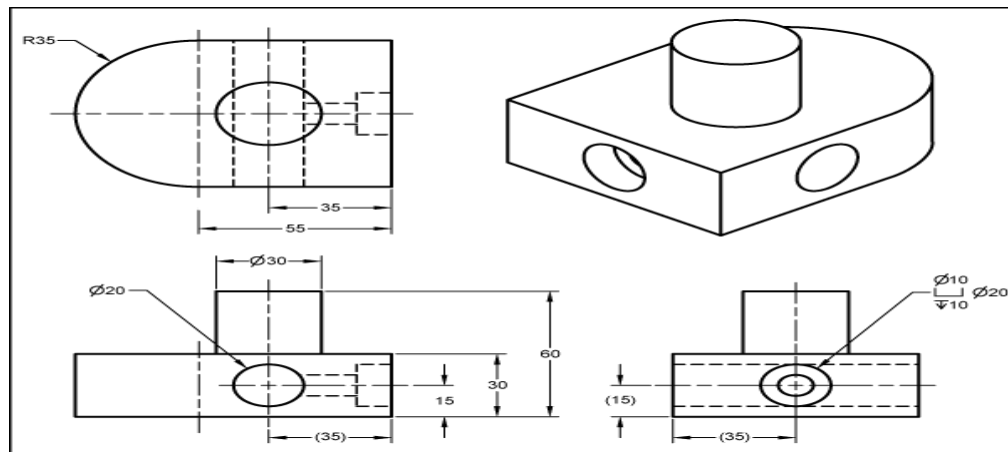

Fig. 3.3.2 isometric view of an object.

### 3.3.2 Dimetric projection

In dimetric projection, the direction of viewing is such that two of the three axes of space appear equally foreshortened, of which the attendant scale and angles of presentation are determined according to the angle of viewing; the scale of the third direction (vertical) is determined separately.

### 3.3.3 Trimetric projection

In trimetric projection, the direction of viewing is such that all of the three axes of space appear unequally foreshortened. The scale along each of the three axes and the angles among them are determined separately as dictated by the angle of viewing. Trimetric perspective is seldom used, and is found in only a few [video games](#)

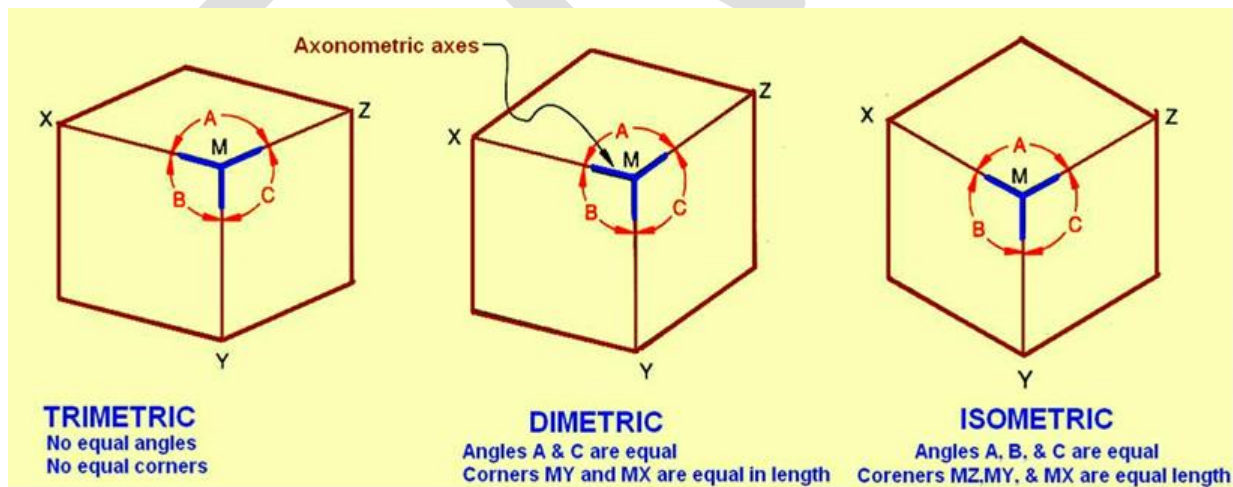

Fig. 3.3 Axonometric projections

### 3.4 Oblique projection

An oblique projection is a simple type of graphical projection used for producing pictorial, two-dimensional images of three-dimensional objects. It projects an image by intersecting parallel rays (projectors) from the three-dimensional source object with the drawing surface (projection plan).

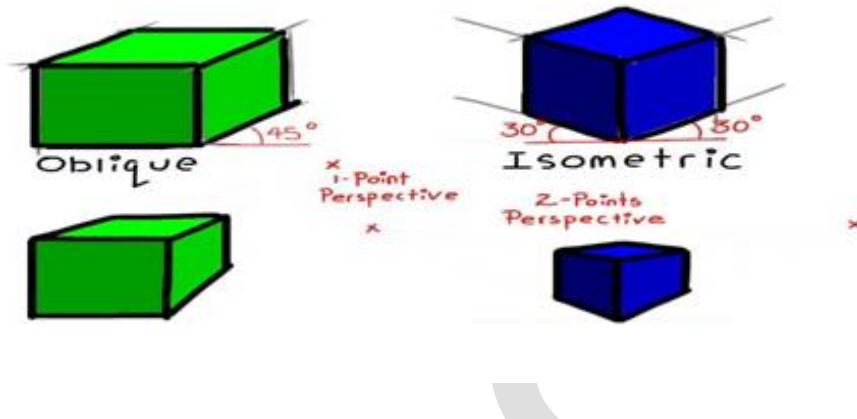

Fig. 3.4 difference between oblique & isometric view

In both oblique projection and orthographic projection, parallel lines of the source object produce parallel lines in the projected image.

### 3.5 Perspective projection

Perspective<sup>12</sup> is an approximate representation on a flat surface, of an image as it is perceived by the eye. The two most characteristic features of perspective are that :

- objects are drawn smaller as their distance from the observer increases.
- Foreshortened: the size of an object's dimensions along the line of sight relatively shorter than dimensions across the line of sight.

Perspective projection is a type of drawing that graphically approximates on a planar<sup>13</sup> (two-dimensional) surface (e.g. paper) the images of three-dimensional objects so as to approximate actual visual perception. It is sometimes also called perspective view or perspective drawing or simply perspective. All perspectives on a planar surface have some degree of distortion, similar to the distortion created when portraying the earth's surface on a planar map.

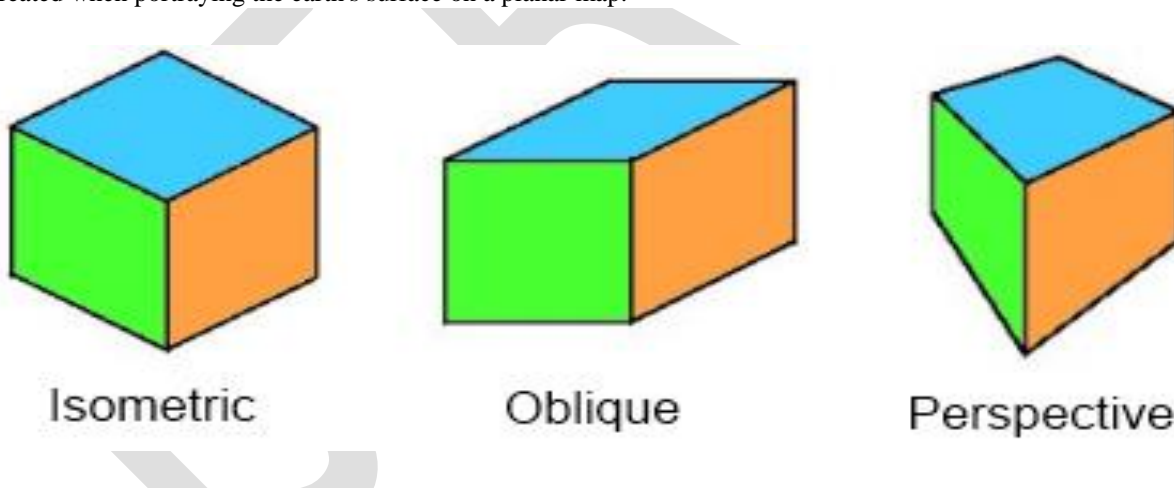

Fig 3.5 different types of views

### 3.6 Section Views

A section view<sup>7</sup> is a view used on a drawing to show an area or hidden part of an object by cutting away or removing some of that object. The cut line is called a “cutting plane”, and can be done in several ways.

Projected views (either Auxiliary or Orthographic) which show a cross section of the source object along the specified cut plane. These views are commonly used to show internal features with more clarity than may be available using regular projections or hidden lines. In assembly drawings, hardware components (e.g. nuts, screws, washers) are typically not sectioned. Projected views are of two types :



### 3.6.1 Full Section

In a full section, the cutting plane line passes fully through the part. Normally a view is replaced with the full section view. The section-lined areas are those portions that have been in actual contact with the cutting-plane.

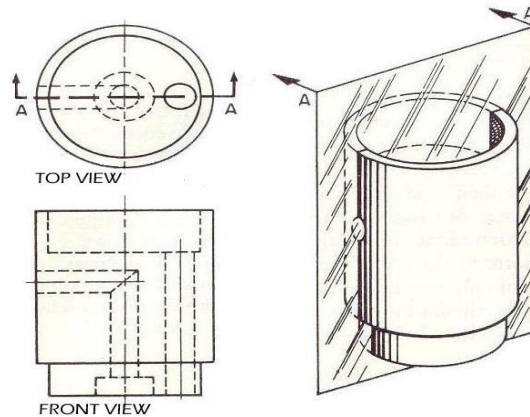

Fig. 3.6.1 full section view.

### 3.6.2 Half Section

Half Section<sup>7</sup> is used to the exterior and interior of the part in the same view. The cutting-plane line cuts halfway through the part and removes one quarter of the material. The line that separates the different types (interior and exterior) may be a centerline or a visible line.

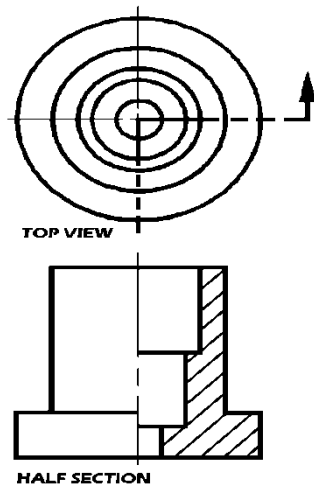

Fig. 3.6.2 half section view.

## CONCLUSION

Technical drawing is a way on which creation of an object is fully depended. So it is necessary to make an accurate drawing for error free production. This paper presents a basic idea for representing complex 3D objects in 2D view in projection line drawings. Main aim of this paper to 1) separate a complex line drawing into simpler ones along its internal faces, 2) reconstruct the 3D shapes from these simpler line drawings, and 3) combine the shapes into a complete object. The future work includes using these drawings with image processing<sup>6</sup> for quality control at production time.

**REFERENCES:**

1. Bertoline, Gary R. Introduction to Graphics Communications for Engineers (4th Ed.). New York, NY. 2009
2. Bhatt, N.D. Machine Drawing. Charotar Publication.
3. Engineering Drawing Practices, ASME Y14.100
4. French, Thomas E.; Vierck, Charles J.; et al (1953), *A manual of engineering drawing for students and draftsmen* (8th ed.), New York, New York, USA: McGraw-Hill, [LCCN 52013455](#)
5. Goetsch, David L.; Chalk, William S.; Nelson, John A. (2000). Technical Drawing. Delmar Technical Graphics Series (Fourth ed.). [Albany](#): Delmar Learning. p. 3. [ISBN 978-0-7668-0531-6](#). [OCLC 39756434](#).
6. Ivan Viola and Meister E. Gröller (2005). "Smart Visibility in Visualization". In: Computational Aesthetics in Graphics, Visualization and Imaging. L. Neumann et al. (Ed.)
7. J. Diepstraten, D. Weiskopf & T. Ertl (2003). "[Interactive Cutaway Illustrations](#)". in: Eurographics 2003. P. Brunet and D. Fellner (ed). Vol 22 (2003), Nr 3.
8. Jefferis, Alan; Madsen, David (2005), *Architectural Drafting and Design* (5th ed.), Clifton Park, NY: Delmar Cengage Learning, ISBN 1- 4018-6715-4
9. Lieu, Dennis K; Sorby, Sheryl (2009), *Visualization, Modeling, and Graphics for Engineering Design* (1st ed.), Clifton Park, NY: Delmar Cengage Learning, [ISBN 1-4018-4249-6](#) , p.1-2
10. Michael E. Brumbach, Jeffrey A. Clade (2003). *Industrial Maintenance*. Cengage Learning, 2003 [ISBN 0-7668-2695-3](#), p.65
11. Ralph W. Liebing (1999). *Architectural working drawings*. John Wiley and Sons, 1999. [ISBN 0-471-34876-7](#).
12. Richard Boland and Fred Collopy (2004). *Managing as designing*. Stanford University Press, 2004. [ISBN 0-8047-4674-5](#), p.69
13. [United States Patent and Trademark Office](#) (2005), [General Information Concerning Patents § 1.84 Standards for drawings](#) (Revised January 2005). Accessed 13 February 2009.