

ANALYSIS OF IMPACT ON COMPOSITE STRUCTURES WITH THE METHOD OF DIMENSIONALITY REDUCTION

UDC 539.3

Valentin L. Popov

Berlin University of Technology, Germany
National Research Tomsk State University, Russia

Abstract. *In the present paper, we discuss the impact of rigid profiles on continua with non-local criteria for plastic yield. For the important case of media whose hardness is inversely proportional to the indentation radius, we suggest a rigorous treatment based on the method of dimensionality reduction (MDR) and study the example of indentation by a conical profile.*

Key Words: *Contact Mechanics, Impact, Plasticity, Non-local Constitutive Relations, Roughness, Reduction of Dimensionality*

1. INTRODUCTION

Constitutive relations for materials are mostly formulated in terms of stresses and deformations. Correspondingly, the critical behavior of materials is generally described by parameters having the dimension of stress such as yield stress, fracture stress or hardness. Further, the constitutive relations are in most cases assumed to be local relations. However, it is well known that the processes of plastic deformation, damage and fracture, independently of the detailed mechanism, are always non-local processes. For dislocation plasticity, this immediately follows from the mechanism of deformation by formation of shear zones [1]. Each elementary event of plastic deformation is a non-local process [2, 3]. The same is valid for fracture processes: both the initial concept of Griffith [4] and its later microscopic [5] and macroscopic [6] generalizations are intrinsically non-local. In the past, there was much effort to address the non-locality in the frame of gradient generalizations of both theory of elasticity and plasticity [7, 8, 9, 10]. Practitioners often take the non-locality into account by introducing critical stresses

Received: January 02, 2015

Corresponding author: Valentin Popov

Berlin University of Technology, 10623 Berlin, Germany; National Research Tomsk State University, 634050 Tomsk, Russia

E-mail: v.popov@tu-berlin.de

depending on the size of the system or the size (or depth) of indentation. Thus, in [12], it is shown that the strength of micro contacts of Au-Au and Au-Pt is proportional to the contact radius for the contact radiuses between 10 and 100 nm, meaning that the “fracture stress” is inversely proportional to the contact radius. While for metals this size dependence is observed only at a sufficiently small scale, for composites it can be valid already at the macroscopic scale. The same is valid for plastic yielding: the nonlocal nature of plastic deformation leads to the size dependence of the “yield stress”. In [11], it is shown that the indentation hardness of polydimethylsiloxan (PDMS) is inversely proportional to the indentation depth over three decimal orders of magnitude. Similar dependencies are observed by nanoindentation of Au [13]. Such dependence of the characteristic parameters on the size of the system shows of course an inconsistency in the theory and should be replaced by an appropriate non-local formulation.

In the following we confine ourselves to the processes of plastic deformation and damage prior to the complete fracture of a structure. The whole spectrum of non-local yield criteria and thus the dependence of the hardness on the size of an indenter can be very roughly divided into three classes:

- (a) Constant hardness σ_c ,
- (b) Hardness, which is inversely proportional to indentation radius a : $\sigma_c = q_c / a$,
- (c) Hardness, which is inversely proportional to indentation area: $\sigma_c = f_c / a^2$.

In the cases (b) and (c), the hardness is in reality not a proper material parameter. It is rather quantity q_c having the dimension of surface energy density in the case (b) and quantity f_c having the dimension of the force in the cases (c), which now characterize unambiguously the plastic properties.

From the point of view of mechanisms of plasticity, the cases (a), (b) and (c) correspond to the situations where the plastic flow is governed by:

- (a) Volume processes, the characteristic critical quantity having the dimension of energy per volume or stress,
- (b) Surface processes, the characteristic critical property having the dimension of energy per area,
- (c) Line processes, the characteristic critical property having the dimension of energy per unit length.

All known criteria for plastic yielding either coincide with one of these classes or can be considered as their combinations.

In the present paper, we concentrate our attention only on the “intermediate” class of constitutive relations (b) and describe how the impact on materials with such non-local plastic criteria can be described using the *method of dimensionality reduction* (MDR) [14, 15, 16, 17].

2. METHOD OF DIMENSIONALITY REDUCTION

At the first glance, the non-local plasticity criterion (b) seems to be more complicated than the local criterion (a). However, the non-locality in three-dimensional systems can sometimes lead to a much simpler theoretical description than in the case of local relations. In a series of publications by Popov, Hess and co-authors (see e.g. [20, 14, 15, 16]), it is shown that the mechanical properties which in a three-dimensional system are

proportional to the contact diameter, can be easily mapped onto a contact with a one-dimensional elastic foundation. For example, this is the case for the contact stiffness of an arbitrary contact with an elastic half-space. The contact stiffness is proportional to the diameter of the contact and thus can be described naturally by a one-dimensional model. The same property is present in contact conductivity (both electrical and thermal) which thus can be described in the framework of MDR [21]. In the publications [14] and [22], it is shown that the mapping of the contact properties from 3D to 1D is exact for arbitrary bodies of revolution provided some rules are considered for recalculation of the material properties and profiles of the contacting bodies. In the case of plastic deformation with the indentation hardness inversely proportional to the contact radius (and thus the indentation force proportional to the radius), we again have a property, which is directly proportional to the contact radius. It is therefore logically to assume that the indentation with such a yield criterion will be correctly described within a one-dimensional model.

In the following, we shortly recapitulate the basics of the method of dimensionality reduction and then formulate its extension to the description of plasticity. If applied to a contact of a body with an elastic or viscoelastic half-space, the MDR consists of two main independent steps:

I. First, a viscoelastic half-space is replaced by a one-dimensional series of parallel springs with stiffness Δk_z and dash pots with damping constant $\Delta \gamma$ (Fig. 1):

$$\Delta k_z = E^* \Delta x, \quad \Delta \gamma = 4\eta \Delta x, \quad (1)$$

where E^* is the effective elastic modulus

$$\frac{1}{E^*} = \frac{1-\nu_1^2}{E_1} + \frac{1-\nu_2^2}{E_2}, \quad (2)$$

E_1 and E_2 are the Young's moduli of contacting bodies, ν_1 and ν_2 , their Poisson-ratios, and η the dynamic viscosity of the medium.

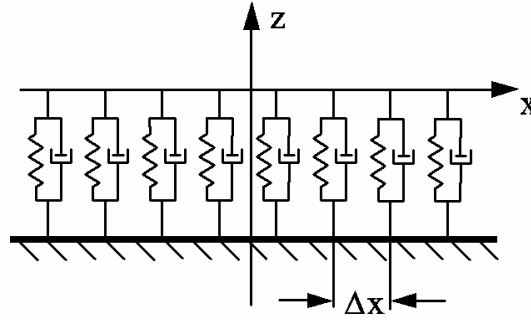

Fig. 1 Equivalent one-dimensional visco-elastic foundation

II. Secondly, the form of the indenter must be recalculated according to the following *rule of Hess*: If a body of revolution is described by equation $z = z(r)$, then the equivalent one-dimensional profile is defined as

$$z_{1D}(x) = |x| \int_0^{|x|} \frac{z'(r)}{\sqrt{x^2 - r^2}} dr. \quad (3)$$

It is proven in [14] and [22] that the contact of the modified 1D profile will provide *exactly* the same relations between the normal force, the indentation depth, and the contact radius as in the initial full three-dimensional problem. If the three-dimensional profile is described by a power-function with an arbitrary positive power n

$$z(r) = c_n r^n, \quad (4)$$

the equivalent one-dimensional profile is a power-function with the same power, but a modified coefficient:

$$z_{1D}(x) = c_n |x| \int_0^{|x|} \frac{nr^{n-1}}{\sqrt{x^2 - r^2}} dr = \tilde{c}_n |x|^n, \quad (5)$$

where

$$\tilde{c}_n = \kappa_n c_n \quad (6)$$

and

$$\kappa_n = \frac{\sqrt{\pi}}{2} \frac{n\Gamma(\frac{n}{2})}{\Gamma(\frac{n}{2} + \frac{1}{2})}. \quad (7)$$

$\Gamma(n)$ is the Gamma-function

$$\Gamma(n) = \int_0^{\infty} t^{n-1} e^{-t} dt. \quad (8)$$

In particular, for a cone ($n = 1$) we get $\kappa_1 = \pi/2$ and for a parabolic profile ($n = 2$) $\kappa_2 = 2$. This last case is known as the *rule of Popov* [14] (Fig. 2).

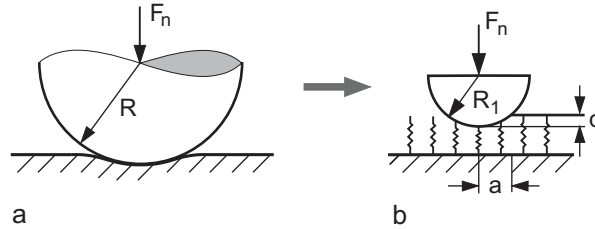

Fig. 2 (a) A three-dimensional contact and
(b) its one-dimensional representation in the MDR

The solution of the one-dimensional problem provides not only correct relations between the global properties (total force, indentation depth and contact radius), but allows to determine the exact three-dimensional distributions of stress. In the elastic foundation, normal forces $f(x)$ of separate springs are immediately determined for any contact configuration. We can define linear force density $q(x)$ by dividing these forces with spacing Δx :

$$q(x) = \frac{f(x)}{\Delta x} . \quad (9)$$

In [14], it is shown, that normal stress $\sigma_{zz}(r)$ in the contact area can be obtained from linear force density $q(x)$ by the following integral transformation:

$$\sigma_{zz}(r) = \frac{1}{\pi} \int_r^\infty \frac{q'(x)}{\sqrt{x^2 - r^2}} dx . \quad (10)$$

3. PLASTICITY CRITERION IN THE METHOD OF DIMENSIONALITY REDUCTION

As stated above, basically all properties which in three dimensions are proportional to the contact radius, can be easily mapped to an appropriate one-dimensional system. For plasticity, this is the case if the indentation force is proportional to the indentation radius:

$$F_N = \pi \sigma_c a^2 = \pi q_c a . \quad (11)$$

It is easily seen that we reproduce this behavior by introduction of the following criterion for plastic yielding of the one-dimensional model described in the previous Section:

$$f_c = \frac{\pi}{2} q_c \Delta x . \quad (12)$$

Note that while the three-dimensional criterion is a non-local one, the corresponding criterion in the equivalent one-dimensional model occurs to be local. Further numerical investigation of the model could lead to another coefficient of proportionality in Eq. (12), but they cannot change the functional form of this relation.

With criterion (12), the complete problem of an indentation in a “visco-elastic, non-locally plastic” medium is reduced completely to a contact problem with a one dimensional elastoplastic foundation with independent elements.

4. IMPACT OF CONICAL PROFILES ON THE MATERIAL WITH A NON-LOCAL YIELD CRITERION

As an illustration, let us consider an impact of a conical profile of the form

$$z = \tan \theta \cdot r \quad (13)$$

with an elastoplastic medium with the non-local yield criterion (11). According to the rule of Hess, the equivalent one-dimensional profile is given by

$$z = \frac{\pi}{2} \tan \theta \cdot |x| . \quad (14)$$

For indentation depth d , the displacement of a spring having coordinate x will be

$$u_z = d - \frac{\pi}{2} \tan \theta \cdot |x| . \quad (15)$$

The contact radius is obtained from condition $u_z(a) = d$, hence,

$$a = \frac{2}{\pi} \frac{d}{\tan \theta}. \quad (16)$$

The spring forces which are still in the elastic state are equal to

$$f(x) = E^* \Delta x \left(d - \frac{\pi}{2} \tan \theta \cdot |x| \right), \quad \text{for } f < \frac{\pi}{2} q_c \Delta x \quad (17)$$

After achieving the critical value, the spring force remains constant and equal to

$$f(x) = \frac{\pi}{2} q_c \Delta x. \quad (18)$$

Up to the indentation depth

$$d_c = \frac{\pi q_c}{2 E^*}, \quad (19)$$

there will be no plastic yielding of any spring. Thus, there exists a critical indentation force F_c for starting the plastic yielding:

$$F_c = 2E^* \int_0^{a_c} u_z(x) dx = 2E^* \int_0^{a_c} (d_c - (\pi/2) \tan \theta \cdot x) dx = \frac{\pi q_c^2}{2E^*} \frac{1}{\tan \theta}. \quad (20)$$

After exceeding the critical force, the inner part of the contact will be in the state of plastic yield. Radius c of the plastically deformed area is given by the condition $f(c) = \pi q_c \Delta x / 2$, hence

$$c = \frac{1}{\tan \theta} \left(\frac{2}{\pi} d - \frac{q_c}{E^*} \right), \quad a - c = \frac{q_c}{E^* \tan \theta} \quad (21)$$

The normal force is given by

$$F_N = 2E^* \int_c^a u_z(x) dx + \pi c q_c = F_c + \pi c q_c = F_c + \frac{2q_c}{\tan \theta} (d - d_c). \quad (22)$$

After achieving the critical state, the normal force increases linearly with the indentation depth.

We do not consider at this point the complete dynamic problem of an impact, which generally can also depend on the structure stiffness. We limit ourselves to the case of a very rapid impact, when the indentation depth is much larger than the critical one. In this case we can write $F_N \approx 2q_c d / \tan \theta$. The work of plastic deformation up to the maximum indentation will be

$$W \approx \int_0^{d_{\max}} \frac{2q_c}{\tan \theta} dd(d) = \frac{q_c d_{\max}^2}{\tan \theta}. \quad (23)$$

The area of contact will be equal to $A_{\max} = \pi a_{\max}^2 = \frac{4}{\pi \tan^2 \theta} d_{\max}^2$.

Thus, the damaged area will be proportional to the impact energy:

$$A_{\max} \approx \frac{4}{\pi q_c \tan \theta} W. \quad (24)$$

This differs from the result for the media with the local plastic criterion, where the impact energy is proportional to the expelled volume [18, 19].

5. CONCLUSION

In the present paper, we considered an indentation of a rigid profile into an elasto-plastic medium with a non-local yield criterion. We considered only the case where the non-locality leads to the inverse proportionality of the indentation hardness to the indentation radius. For such media, we have suggested a generalization of the method of dimensionality reduction and analyzed the case of indentation of a rigid conical indenter. As the method of dimensionality reduction is also valid for tangential contacts [23], the proposed method can be easily generalized for the case of impacts with a tangential component of impact velocity.

Acknowledgements: *Many valuable discussions with S. Psakhie, M. Ciavarella, S. Dubinsky and A. Ushakov are gratefully acknowledged. This work is supported in part by Tomsk State University Academic D.I. Mendeleev Fund Program.*

REFERENCES

1. Popov L. E., Kobayev V. S., Kovalevskaya T. A., 1982, *Concepts of strengthening and dynamic recovery in the theory of plastic deformation*, Russian Physics Journal, 25, pp. 520-541.
2. Popov L. E., Slobodskoi M. I., Kolupaeva S. N., 2005, *Simulation of single slip in FCC metals*, Russian Physics Journal, 49, pp. 62-73.
3. L. E. Popov, Kolupaeva S.N., Vihor N.A., Puspesheva S.I., 2000, *Dislocation dynamics of elementary crystallographic shear*, Computational materials science, 19(1), pp. 267-274.
4. Griffith A.A., 1921, *The phenomena of rupture and flow in solids*, Philos. Trans. R. Soc. Lond. Ser. A, 221, pp.163–198.
5. Prandtl L., 1933, *Ein Gedankenmodell für den Zerreivorgang spröder Körper*, ZAMM, J. Appl. Math. Mech., 13, pp. 129–133.
6. Rice J.R., 1968, *A Path Independent Integral and the Approximate Analysis of Strain Concentration by Notches and Cracks*, Journal of Applied Mechanics, 35, pp. 379–386.
7. Aifantis E.C., 1999, *Strain gradient interpretation of size effects*, Int. J. Fracture, 95, pp. 299–314.
8. Nix W.D., Gao H., 1998, *Indentation size effects in crystalline materials: a law for strain gradient plasticity*, Journal of the Mechanics and Physics of Solids, 46(3), pp. 411-425.
9. Gao H., Huang Y., Nix W.D., Hutchinson J.W., 1999, *Mechanism-based strain gradient plasticity—I. Theory*, Journal of the Mechanics and Physics of Solids, 47(6), pp.239-1263.
10. Popov V.L., 1992, *Gauge theory of plastically incompressible medium without dissipation. 1. Dispersion relations and propagation of perturbations without dissipation*, International Journal of Engineering Science, 30, pp. 329-334.
11. Wrucke A.J., Han C.-S., Majumdar P., 2013, *Indentation size effects of multiple orders of magnitude in Polydimethylsiloxane*, J. Appl. Polym. Sci., 128, pp. 258–264.

12. Budakian R., Putterman S.J., 2002, *Time scales for cold welding and the origins of stick-slip friction*, Phys. Rev. B, 65, pp. 235429.
13. Corcoran S.G., Colton J., 1997, *Anomalous plastic deformation at surfaces: nanoindentation of gold single crystals*, Phys. Rev. B, 55 pp. R16057.
14. Hess M., 2012, *On the reduction method of dimensionality: The exact mapping of axisymmetric contact problems with and without adhesion*, Phys. Mesomech., 15(5-6), pp. 264-269.
15. Popov V.L., Hess M., 2013, *Methode der Dimensionsreduktion in Kontaktmechanik und Reibung – Eine Berechnungsmethode im Mikro- und Makrobereich*, Springer-Verlag.
16. Popov V.L., 2013, *Method of reduction of dimensionality in contact and friction mechanics: A linkage between micro and macro scales*, Friction, 1(1), pp. 41-62.
17. Popov V.L., Hess M., 2014, *Method of dimensionality reduction in contact mechanics and friction*, Springer.
18. Popov V.L., 2010, *Contact Mechanics and Friction. Physical Principles and Applications*, Springer-Verlag, 362 pp.
19. Kleis I., Kulu P., 2008, *Solid Particle Erosion, Occurrence, prediction and control*, Springer, 206 pp.
20. Popov V.L., Psakhie S.G., 2007, *Numerical simulation methods in tribology*, Tribology International, 40, pp. 916-923.
21. Hess M. and Popov V.L., 2013, *Wärmeleitung und Wärmeerzeugung*, In: Popov, V.L. and Hess, M., *Methode der Dimensionsreduktion*, Springer, pp. 115-131.
22. Hess M. and Popov V.L., 2013, *Exakte Lösungen in drei Dimensionen für den Normalkontakt rotationsymmetrischer Körper*, In: Popov V.L. and Hess M., *Methode der Dimensionsreduktion*, Springer, pp. 227-239.
23. Hess M. and Popov V.L., 2013, *Exakte Lösungen in drei Dimensionen für den Tangentialkontakt rotationsymmetrischer Körper*, In: Popov V.L. and Hess M. (Eds.), *Methode der Dimensionsreduktion*, Springer, pp. 227-239.