

Child activity monitoring using sensors

Mr. D K Kamat¹, Ms. Pooja S Ganorkar², Mrs. R A Jain³

1(Asst Prof, E&TC department, Sinhgad Academy of Engineering, Kondhwa(BK), Pune and Research Scholar SCOE, Pune)

2(Savitribai Phule Pune University, E&TC department, Sinhgad Academy of Engineering, Kondhwa(BK), Pune)

3(Asst Prof, E&TC department, Sinhgad Academy of Engineering, Kondhwa(BK), Pune)

Abstract:

This paper presents the activities of children in Epilepsy in which a person has repeated or recurrent seizures over time. In this, the particular person suffers from symptoms such as violent shaking, non controllable jerky movements of the arms and legs, loss of alertness etc. But in the proposed model, we are using the wearable sensors which will be worn on the brain and palms to detect the epileptic attacks and the GSM is used so that the message is send through mobile to their relatives or friends that an attack has occurred. Proper medicines can cure this disorder so we are going to suggest medicines according to the type of seizure. The readings will be displayed on flex grid. The sensors include two 3-axis accelerometer sensors, temperature sensor, moisture sensor. This model will utilize the ARM LPC2138 processor and the programming will be developed in keil3. Software includes Visual Basics. So we will be doing the monitoring as the seizure will be detected and their parents or relatives will be knowing about it. We are going to detect generalized tonic clonic seizures, absence seizures.

Keywords — Epilepsy, flex grid, GSM, sensors, types of seizures.

I. INTRODUCTION

In recent years, automatic identification of human activities has drawn much attention due to the increasing demands from various applications such as surveillance system, entertainment systems and healthcare systems. The automatic detection of abnormal activities, for example automatic reporting of a person with a bag hanging around at the station or airport, can be used to alert the related authority about the dangerous activity in surveillance system. Similarly, in an entertainment system, the automatic activity recognition can be used to improve the interaction of human with the computer. Further, in healthcare systems, the activity recognition can be used to help the patients, such as identifying a dangerous activity performed by a patient. Although various activity recognition methods have been reported, the human activity recognition is one of the difficult issues in terms of perfect recognition.

Epilepsy is the disorder in which the person suffers from various types of seizures. In this, the person gets an attack and it may lasts from seconds to minutes. Forty-five million people all over the world have epilepsy, and each year 125,000 to 150,000 people are newly diagnosed with the condition in the United States. About 30 percent of these are children. The person can injure himself when he gets an attack and he may get serious. So this disease may lead to death [2].

Generalized tonic-clonic seizures (GTCS), especially when not taken care, they are related with an increased risk of injuries, and also for unexpected sudden death in epilepsy which came to know by [5],[7]. Some EEG based seizure detection algorithms are there, and implemented in many epilepsy monitoring units, but only a few patients were allowed to use EEG electrodes on a long-term basis for signal acquisition [11]. Previous studies for the detection of convulsive seizures based on accelerometer signals alone [6],[8],[10] or in combination with other modalities [4],[9] showed promising results. But all of those studies contains

algorithms which were used for the offline detection of the convulsions or seizures in the recorded data.

So there is a need to monitor the activities of seizure because it will help to know that when the attacks came and for how much time they had lasts. The main advantage is to monitor the life time seizure attacks.

A seizure is a sudden attack caused by an abnormal electrical discharge in the brain so people experience it as altered awareness (for example, losing consciousness), involuntary movements, or convulsions [3]. Seizures may come from high fever (called febrile seizures) or heatstroke, severe sleep deprivation, diabetes (if blood sugar levels become too low or too high), drug or alcohol withdrawal, or a reaction to medications. Therefore it is good if we are using our model for this purpose.

Most common symptoms of epilepsy include violent shaking, loss of alertness, temporary confusion, uncontrollable jerky movements of the arms and legs, loss of consciousness or awareness, psychic symptoms. Two types of seizures have been detected each producing different symptoms.

1.Generalized tonic-clonic seizures - During such a type, a person suddenly starts to lose consciousness and falls down. All the muscles of the body may contract in a sustained fashion at once called as tonic, or they can contract in a series of rhythmic contractions called as clonic, or it may be both. Also the person may pass urine in such an attack. The seizure attack typically lasts for about 90 seconds and is followed by a brief period of deep stupor, then a longer period of lethargy and confusion. Many people experience headaches, muscle aches, lack of energy, inability to concentrate, and mood changes for up to 24 hours after the seizure.

2.Absence seizures - It occurs mainly in children. They are characterized by sudden few small jerks of the hands or arms. Most last for less than ten seconds. Because behavior and awareness return immediately to normal, so that a person usually has no idea that a seizure has occurred. Absence seizures can occur hundreds of times a day.

The arrangement of this paper is as follows: Section II gives implementation of paper, Section III gives Methodology with A) hardware part and explanation of respective Blocks and B) software part, Section IV Performance testing and Result and V is conclusion and VI future scope.

II. Implementation of paper

In this paper, we are going to monitor the attacks from the types of seizures. The hardware part consists of various types of sensors which will be worn on the brain and palms and the respective readings will be displayed on flex grid which is the software part ie. visual basics.

III. Methodology and Material

I. Hardware Development

The objective of the present paper is: 1) to detect the attacks occurring through various types of seizure. 2) to suggest the medicines for particular type of seizure. 3) Sensors play an important role as they are going to recognize an attack and an SMS is send through GSM on mobile that an attack has occurred and an attack has gone. 4) It will characterize the various types of seizures which have its own symptoms. The key is pressed for a particular type of seizure on VB and the results will be displayed on flex grid with time, date etc.

This section describes the design of the model. The block diagram of system is shown in figure 1.

The model consists of microprocessor ARM-LPC 2138. It includes LCD, two accelerometer sensors, temperature sensor, moisture sensor, GSM module.

A. Components used

1) LPC2138: The LPC2138 microcontrollers works on a 16/32-bit ARM7TDMI-S CPU with real-time emulation and embedded trace support, which combines the microcontroller with 32 kB, 64 kB, 128 kB, 256 kB and 512 kB of embedded high-speed flash memory. Because of their tiny size and low power consumption, these microcontrollers are suitable for applications where miniaturization is a primary requirement, such as access control and point-of-sale.

2) Liquid Crystal Display: LCD is used to see the output of the application. We have used 16x2 LCD which indicates 16 columns and 2 rows. So, we can write total 16 characters in each line. So, overall 32 characters we can display on 16x2 LCD.

LCD is also used in a project to check the output of different modules which is interfaced with the microcontroller. Thus LCD plays an important role in a project to see the output and to debug the system module wise in case of system failure in order to rectify the problem.

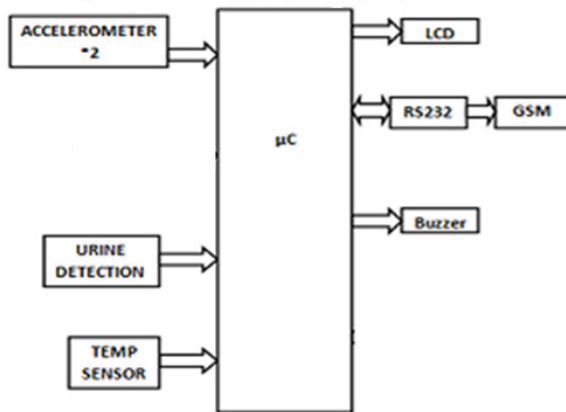

Figure1: System Block Diagram.

3) RS232: RS 232 IC is a driver IC to convert the μC TTL logic (0-5) to the RS 232 logic (+/-9v). Many devices today work on RS 232 logic such as GSM modem, PC, GPS etc. So in order to communicate with such devices, we have to bring down the logic levels to the 232 logic (+/-9v).

4) Temperature sensor: Temperature sensor senses the temperature. We have used a Temperature sensor which is called as LM35. It is calibrated directly in degree centigrade. It has Linear +10.0mV/degree centigrade scale factor and also 0.5 degree centigrade accuracy. Due to wafer level trimming, it has low cost. This temperature sensor can sense the temperature of the atmosphere around it or the temperature of any machine to which it is connected or even can give the temperature of the human body in case if it is used. So, irrespective of the application to which it is

used, it will give the reading of the temperature. The LM35 series are temperature sensors precision integrated-circuit, where its output voltage is linearly proportional to the Celsius or Centigrade temperature.

Temperature sensor is an analog sensor and it gives the output into the form of analog signal. This signal is given to ADC which will convert it into digital form. When it is converted into analog form, the microcontroller will process the digital temperature signal according to the application.

5) Accelerometer: An accelerometer is a device which is electromechanical used to measure acceleration forces. These acceleration forces are of two types- they can be static, such as the force of gravity which is constant and pulls at your feet, or they can be dynamic which is caused by moving or vibrating the accelerometer.

By calculating the amount of static acceleration caused by gravity, we are able to detect the angle of the device which is tilted with respect to the earth. By experiencing the amount of dynamic acceleration, we can recognize the way the device is moving.

Accelerometers use the piezoelectric effect – so they include microscopic crystal structures which get stressed by accelerative forces, and cause a voltage to be generated. Second way to do it is by experiencing changes in capacitance. If two microstructures are there next to each other, then they have some capacitance amongst them. If an accelerative force moves one of the structures, then the capacitance will vary accordingly. Adding some circuitry and converting it from capacitance to voltage, we will get an accelerometer.

The three axis accelerometer are actually used to identify the movements across the three axis i.e. x-axis, y-axis, z-axis. Accelerometer is an electronic device which is interfaced using I2C protocol and it provides the reading after every 1msec. According to the requirement of the application, the microcontroller will take the reading from the accelerometer within a fixed interval of time and perform the necessary operation according to the requirement of the application.

6) GSM modem: GSM (Global System for Mobile communication) is a digital mobile telephony system.

By using the GSM module interfaced, we can send short text messages to the required authorities as per the application. GSM module is provided by SIM. It uses the mobile service provider and send SMS to the related authorities as per programmed. This technology enables the system a wireless system with unspecified range limits. GSM uses a variation of time division multiple access (TDMA) and is the most usually used of the three digital wireless telephony technologies (TDMA, GSM, and CDMA).

II. SOFTWARE DEVELOPMENT

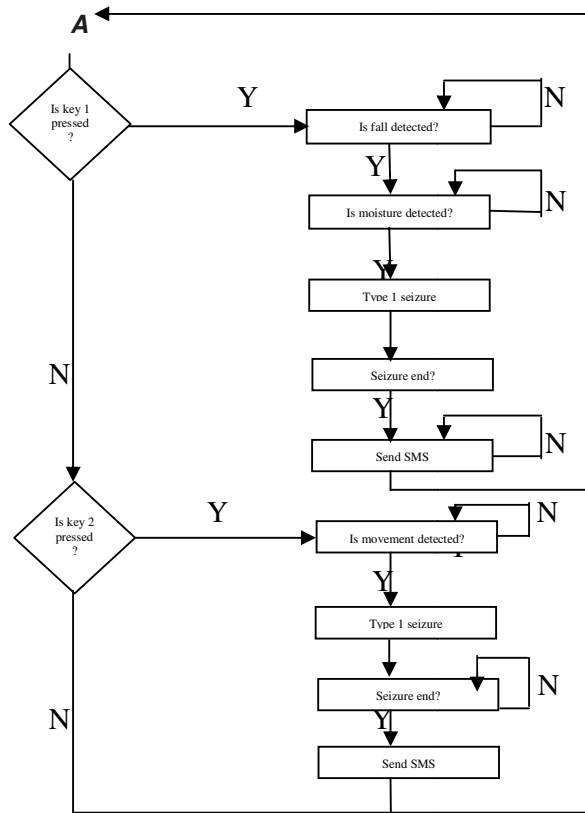

Fig.2. Flow chart of the software part

The flow is shown in fig.2. VB software is used in the proposed model. Two ports are connected to the

computer. One port takes the data from GSM and the other port takes the data from hardware. By connecting the single port at once, we will be able to know which type of port it is. Then selecting the two ports will initialize the code and successfully completing it will give the desired readings. We will first select the type of seizure so that the controller will continuously send data to VB. On VB, there is a timer of 1 minute for complex partial seizure. And for other types, it will check the condition after every 5 sec. All the readings will be shown on flex grid. SMS will be sent at the start of the seizure as well as at the end of the seizure.

IV. Performance Testing

These are the readings for generalized tonic clonic seizures. Here, we have done monitoring for only two types of seizures. It uses the keypad. Accordingly the sensor starts to detect the symptoms and will display the readings as shown in fig 3.

| Child Activity Monitoring | | | | | | | |
|---------------------------|----------|------------|-------------|---------------|---------------|----------|--|
| Mobile No | | 9975679311 | | | | | |
| Date | Time | Type | Temperature | Head Movement | Palm Movement | Moisture | |
| 29/04/2015 | 18:47:11 | 1 | 33.4 | Normal | Normal | 0012 | |
| 29/04/2015 | 18:47:15 | 1 | 33.6 | Normal | Normal | 0012 | |
| 29/04/2015 | 18:47:23 | 1 | 34.5 | Normal | Normal | 0012 | |
| 29/04/2015 | 18:47:27 | 1 | 33.8 | Absent | Normal | 0010 | |
| 29/04/2015 | 18:47:31 | 1 | 33.5 | Absent | Normal | 0006 | |
| 29/04/2015 | 18:47:35 | 1 | 33.4 | Absent | Normal | 0006 | |
| 29/04/2015 | 18:47:40 | 1 | 33.8 | Absent | Normal | 0006 | |
| 29/04/2015 | 18:47:43 | 1 | 33.5 | Absent | Normal | 0007 | |
| 29/04/2015 | 18:47:47 | 1 | 33.3 | Absent | Normal | 0007 | |
| 29/04/2015 | 18:47:51 | 1 | 33.4 | Absent | Normal | 0006 | |
| 29/04/2015 | 18:47:55 | 1 | 33.8 | Absent | Normal | 0007 | |

Fig.3. Readings we get after pressing the key for particular type of seizure which includes date, time, type, temperature, head movement, palm movement, moisture.

And SMS will be delivered to their parents or doctor when the seizure starts and seizure ends for that particular number. And all these readings are displayed on flex grid.

V. Conclusion

In the proposed work, we are going to detect the attacks of the types of seizures suffering from

various symptoms. So an SMS is send about when an attack came and when an attack has gone. It will help to know about the number of attacks and also one can prevent the attack or injuries he might do after an attack. So this project is for life time activity monitoring.

VI. Future Scope

We can do this for other types of seizures also which will cover everything. Also some other technology can be developed including EEG and sensors combinely.

ACKNOWLEDGMENT

I would like to thank my guides, Mr. D. K. Kamat and Mrs. R. A. Jain for their guidance and support, for providing his valuable guidance and their precious time to make this project a success. I would like to express my devoted regards and reverence to the P.G. Coordinator Dr. R.P.Borse and the H.O.D of E&TC Department Prof. M.M.Sardeshmukh for their whole hearted support and guidance and their keen interest during the progress of my project.

References

- [1] Yunyoung Nam and Jung Wook Park, "Child Activity Recognition Based on Cooperative Fusion Model of a Tri-axial Accelerometer and a Barometric Pressure Sensor", *IEEE Journal of Biomedical and Health Informatics*, VOL. 17, NO. 2, MARCH 2013.
- [2] *Epilepsy and Seizures — The Dana Guide* by Timothy A. Pedley March, 2007.
- [3] Available from website 'Epilepsy Facts, information, pictures _ Encyclopedia.com articles about epilepsy.htm'.
- [4] Conradsen I, Beniczky S, Wolf P, Henriksen J, Sams T, Sorensen HB. Seizure onset detection based on a Uni modal or multi-modal intelligent seizure acquisition (UISA/MISA) system. *Conf Proc IEEE Eng Med Bio Soc* 2010:3269–3272.
- [5] Hesdorffer DC, Tomson T, Benn E, Sander JW, Nilsson L, Langan Y, Walczak TS, Beghi E, Brodie MJ, Hauser A, IL *Epidemiology, Subcommission on Mortality*. (2011) *Combined analysis of risk factors for SUDEP. Epilepsia* 52:1150–1159.
- [6] Kramer U, Kipervasser S, Shlitner A, Kuzniecky R. (2011) 'A novel portable seizure detection alarm system: preliminary results'. *J Clin Neurophysiol* 28:36–38.
- [7] Lhato SD, Johnson AL, Goodridge DM, MacDonald BK, Sander JW, Shorvon SD. (2001) 'Mortality in epilepsy in the first 11 to 14 years after diagnosis: multivariate analysis of a long-term, prospective, population-based cohort'. *Ann Neurol* 49:336–344.
- [8] Nijssen TME, Arends JBAM, Griep PAM, Cluitmans PJM. (2005) 'The potential value of three-dimensional accelerometry for detection of motor seizures in severe epilepsy'. *Epilepsy Behav* 7:74–84.
- [9] Poh MZ, Loddenkemper T, Reinsberger C, Swenson NC, Goyal S, Sabtala MC, Madsen JR, Picard RW. (2012) 'Convulsive seizure detection using a wrist-worn electrodermal activity and accelerometry biosensor. *Epilepsia*' 53:e93–e97.
- [10] Schulc E, Unterberger I, Saboor S, Hilbe J, Ertl M, Ammenwerth E, Trinka E, Them C. (2011) 'Measurement and quantification of generalized tonic-clonic seizures in epilepsy patients by means of accelerometry— an explorative study. *Epilepsy Res*' 95:173–183.
- [11] Schulze-Bonhage A, Sales F, Wagner K, Teotonio R, Carius A, Schelle A, Ihle M. (2010) 'Views of patients with epilepsy on seizure prediction devices. *Epilepsy Behaviour*' 18:388–396.