



## Use of optical fibre technology to measure structural performance

Laurie F. Boswell\*, Brett McKinley

*Department of Civil Engineering, School of Engineering and Mathematical Sciences, City University, London EC1V 0HB, UK*

### ABSTRACT

Structural monitoring using optical fibre technology may be undertaken to establish the long-term behaviour of structures, components and materials of construction. Condition monitoring may be used as an aid to repair and strengthening schedules. The establishment of material durability is also part of the monitoring process. The paper describes and discusses the application and development of the use of optical fibres to monitor structures. Examples have been given in which strain, temperature and moisture content have been determined for structural elements and materials of construction. Of particular interest is the use of an optical fibre monitoring system to determine the performance of an actual bridge, which has been subjected to controlled loading conditions. The results, which have been described, demonstrate the enormous potential to monitor structures using optical fibres.

### ARTICLE INFO

*Article history:*

Received 14 May 2015

Accepted 3 June 2015

*Keywords:*

Structural monitoring

Optical fibres

Bridge maintenance

Durability

Composite construction

### 1. Introduction

There has been considerable effort in recent years for increasing the understanding of the long-term behaviour of civil engineering and other structures through the use of advanced monitoring techniques using optical fibre based instrumentation (Ferdinand et al., 1994; Measures et al., 1995; Ning et al., 1998; Grattan and Meggitt, 2000a; Grattan and Meggitt, 2000b; Betz et al., 2002; Maurin et al., 2002).

This paper highlights some of the recent research activity conducted at City University in collaboration with other national and international institutions. This activity has seen the establishment of monitoring systems for strain and temperature, which have been deployed in steel, concrete and composite structures in the laboratory and concrete, steel-concrete composite and polymer composite structures in the field.

The existing ability to monitor extensively large structures has been limited by the available strain sensors which rely on electrical instrumentation that is time consuming to install, requires a large amount of electrical inter-connections, can be difficult to distribute over large distances and to embed during the construction process. The quasi-distributed, multiplexed optical fibre sensor

systems developed will provide invaluable information regarding the stress relief, shrinkage, creep, dead loading, post tensioning and structural degradation manifested by the appearance of cracks, fissures and corrosion. Further, it will permit the possibility for monitoring the static and dynamic loading history that is essential in both setting controlled maintenance procedures and scheduling and for structural design assessment. This provides a powerful means to determine the service quality and safety in a continuous fashion, both during and after construction, throughout the structures lifetime and especially approaching its designed life-span and following unusual phenomena such as subsidence, earth-quakes, impact, high wind, fire and flooding to avoid catastrophic failure.

Considerable attention has been directed towards the possible application of optical fibres for civil engineering use. Although a range of possible transducer principles has been investigated including strain, temperature, acceleration, moisture and various chemicals, the development of the in-fibre Bragg grating has provided a step forward in the potential capabilities of the technology for large structure monitoring. This and compatible temperature systems has been the basis of research activity at City University.

\* Corresponding author. Tel.: +44-20-70408140 ; Fax: +44-20-70400119 ; E-mail address: l.f.boswell@city.ac.uk (L. F. Boswell)

## 2. Optical Fibre Instrumentation Technology

### 2.1. Strain measurement

The Bragg grating structure is written as a periodic variation in the refractive index of a photosensitive fibre providing a strain and temperature dependent optical filter. The grating effectively acts as a wavelength specific mirror whilst allowing all other light to pass almost perfectly in order to interrogate further gratings if used in a multiplexed system, Fig. 1.

The grating forms the basis of optical strain measurements, which can be monitored by measuring the changes in the wavelength spectrum of the reflected optical signal. It allows an absolute measurement that is independent of potential intensity fluctuations caused by

light source variation, fibre bending loss or connector attenuation. It is simple and encapsulates all the benefits of optical fibre technology. This is a major advantage of Bragg grating sensors for long term monitoring in large engineering structures where the service lifetime of the structure is considerable. As passive optical sensing devices, immune to electromagnetic interference, Bragg gratings encapsulate all the advantages of fibre optic sensors (Grattan and Meggitt, 2000a). As they are written directly into the fibre, they are hence unobtrusive and small in size (barely visible in Figs. 2 and 3), allowing easy sensor embedment for smart structure applications. In addition, several gratings can be written in series along a single fibre at different wavelengths for quasi-distributed sensing, a major advantage of the use of this approach.

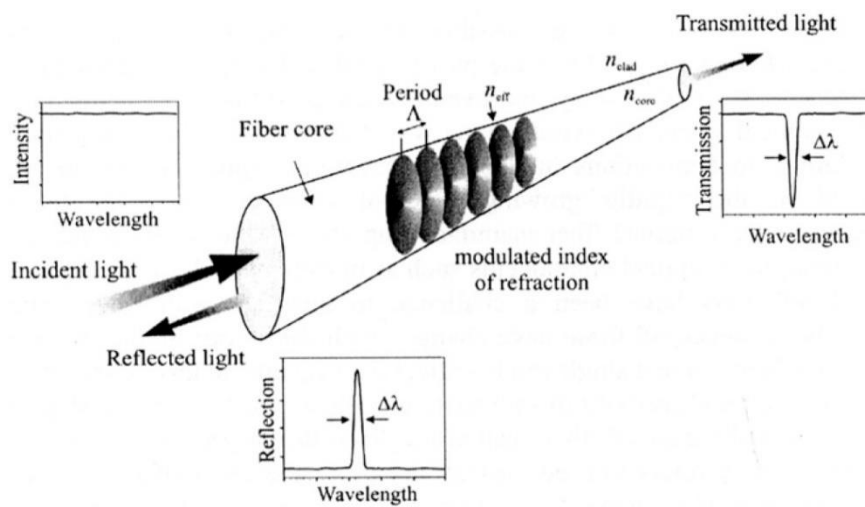

Fig. 1. Schematic representation of operation of FBG based strain instrumentation.



Fig. 2. Installed optical fibre sensors on steel structure.



Fig. 3. Strain gauges and optical fibre sensors on failed concrete specimens.

### 2.2. Temperature determination

The prime aim of recent activity is the development of a fibre-based sensor system for temperature monitoring, using a technique complementary to the Bragg grating based system for strain monitoring.

This would allow the measurement of temperature during the exothermic process of concrete curing; and would provide a mechanism to compensate changes in the strain measurements within a structure caused by changes in temperature. The method proposed requires the use of small temperature-sensitive elements of

doped fluorescent fibre, the fluorescence decay time of which can be monitored as a function of temperature. This technique is sensitive over the whole range of temperatures to be measured in the structure (-20 to +300°C) and utilises the same wavelengths as the strain

measurement system, to simplify the optical system used. The signal processing can be constructed using readily available electronic components, to yield a precision of  $\pm 2^\circ\text{C}$  with the probe in-situ. Fig. 4 shows the probe design.

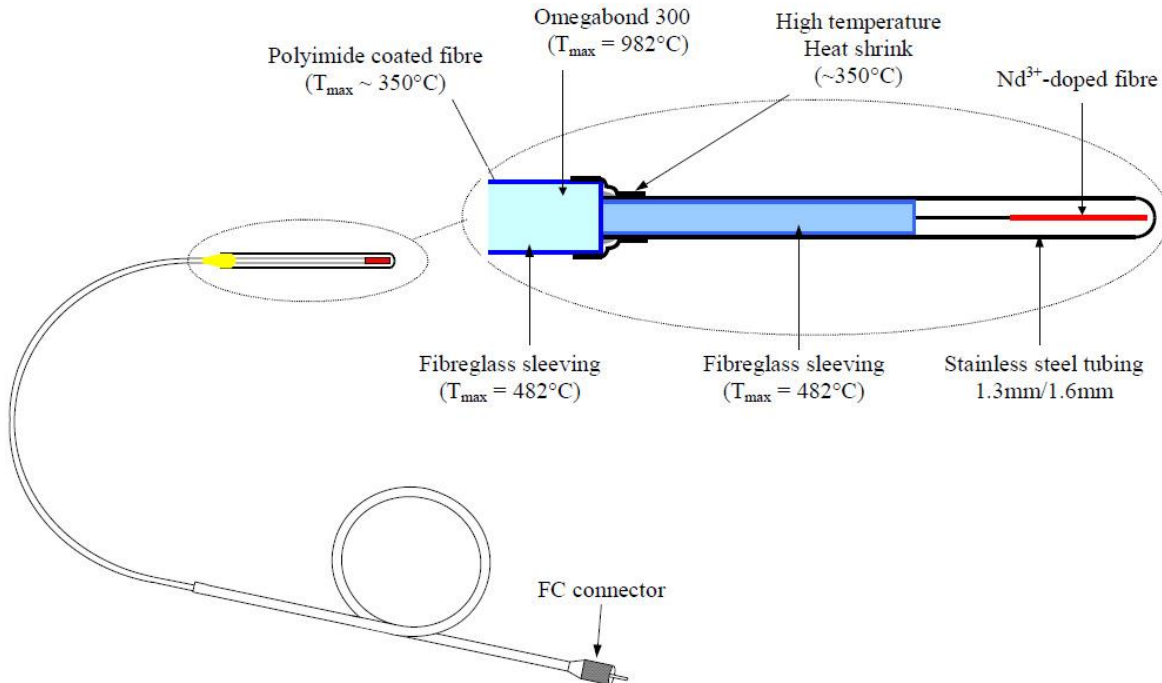

Fig. 4. Design of optical fibre temperature probe for temperatures up to 350°C, and installed in a reinforcement cage.

### 3. Applications

The application of optical fibre sensors to civil engineering structures has been developed and proven through extensive laboratory testing prior to being implemented on a number of bridges made from a range of materials including steel, concrete and polymer composites. Some examples of the work are given.

#### 3.1. Strain and temperature measurements for concrete beams

A series of tests using reinforced concrete beams was used to evaluate the durability of the optical fibre sensors exposed to high temperature. The dimensions of the beams were: length 850 mm, height 85 mm and width 60 mm and were tested using existing apparatus capable of applying structural loads to failure and thermal loads to 800°C. This work was carried out using the optical fibre based temperature sensor as well as FBG optical fibre sensors for strain and temperature, electrical resistance strain gauges and thermocouples.

Initially the beam was loaded up to approximately 10kN (40% static capacity) at ambient temperature, during which the temperature of the beam was monitored using both a K-type thermocouple and an optical fibre temperature probe. After the initial loading of the concrete beam the temperature of the beam was raised in

stages of approximately 100°C, up to a maximum of 300°C, with the beam temperature being allowed to stabilise for each heating stage. Once the beam had stabilised at each of the set temperatures the applied load was increased back to 10kN. The reduction in the load applied to the beam during each of the heating stages was due to expansion of metal components in the test rig.

Some small changes in temperature readings that occurred during the test were accompanied by failure of two strain gauges mounted on the steel reinforcement of the concrete beam, indicating that a substantial change in the beams' mechanical properties has occurred. Further evidence of this fact was indicated when visual inspections of the beam upon later removal from the test rig found flexural cracks of the concrete in the middle section of the beam allowing more direct and rapid heating of the area around the sensors.

FBG sensors were also used to measure strain and to compensate for temperature variations within concrete beams subjected to structural and thermal loads. Two FBG sensors were installed in the concrete beam with one attached to the steel reinforcement and the other inserted into a glass capillary in order that it would only be subjected to thermal variations and was located adjacent to the first sensor. The strains measured by the FBG sensor on the reinforcement were successfully compensated as indicated by a comparison with the conventional gauges, Fig. 5.

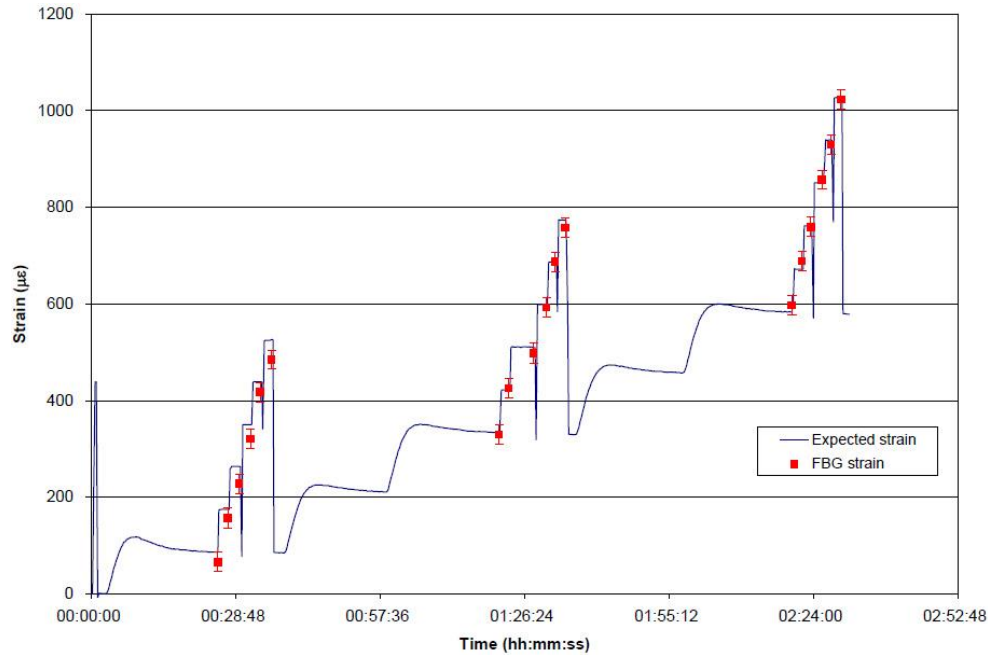

Fig. 5. Comparison of temperature compensated FBG sensors to strain gauge measurements.

### 3.2. Durability of concrete cylinders

A programme of work to characterise and catalogue the effect of damage development in dry and preconditioned concrete cylinders and cubes as a function of applied load and curing environment was undertaken. The specimens were cured under four different conditions and then loaded to a series of pre-defined levels and then unloaded, sectioned, inspected and the results catalogued. The damage behaviour as a function of load and environment was correlated to the output from the FBG sensors attached to the cylinders and to ultrasonic pulse velocities, which is a common method of measuring relative, in-situ degradation of concrete structures.

The measured ultrasonic pulse velocities indicate change from approximately 30% of the concrete cube strength. The changes at this level were within the noise variations of the system and would only be detectable after many readings. The method was, therefore, assessed to be only of use once significant load had been placed on the specimen.

The data from the FBG sensors was correlated to the behaviour of concrete cylinders under load before and after compensating for non-axial loading. This showed significant difference in the stress-strain behaviour between the concrete cylinders cured under the different environmental conditions. The strength of the concrete under the different curing regimes is as expected based on the amount of moisture available for concrete hydration. The specimens cured under control conditions achieved near design 28 day strengths of 40 N/mm<sup>2</sup> with the higher humidity levels causing increased strength.

The samples cured in air had reduced strength. There was a clear change in the stress-strain response between the specimens, as measured using the optical fibre sensors, which is easily detectable from low level and, therefore, significant better than any visual inspection.

### 3.3. Fatigue tests on concrete beams

A series of tests using reinforced concrete beams were subjected to dynamic fatigue loading at various load levels to determine the performance of sensors at low loading (up to 10<sup>6</sup> cycles), intermediate and high loading (<1000 cycles). A single FBG optical fibre sensor together with two electrical resistance strain gauges was used for monitoring the compression strains at the centre of the test specimens, Fig. 3. The design of the beams is such that failure will occur by concrete compression at the mid span.

A beam loaded at low levels was seen to steadily increase the strain range response throughout the test until after 6.5x10<sup>5</sup> cycles, where it remained steady. The specimen did not fail and the test was halted after 10<sup>6</sup> cycles. Specimens that were highly loaded showed rapid degradation of the beam by the continuously increasing strain range and increasing residual strain within the beam. Some sudden drop-offs in the signal were caused by the wavelength of the reflected light from the Bragg falling outside the range of the detection system indicating the need to match the Bragg sensor to the requirements.

Fig. 6 shows the number of cycles to failure from nine concrete beam tests, which have been subjected to various load ranges. Two of the specimens did not actually fail and are highlighted by the dotted lines indicating when the failure might be expected to occur. Some degree of scatter has occurred in the results, which is attributed to the nature of concrete. When results from the beam tests unexpectedly occurred, concrete cube tests were taken but little discrepancy in their results was ever found. Fig. 6 shows that most of the scattered results occurred when loaded around 50 to 60% of the maximum static capacity. The results from this work have enabled a fatigue curve to be generated for concrete in compression, although this only applies to one concrete specification.



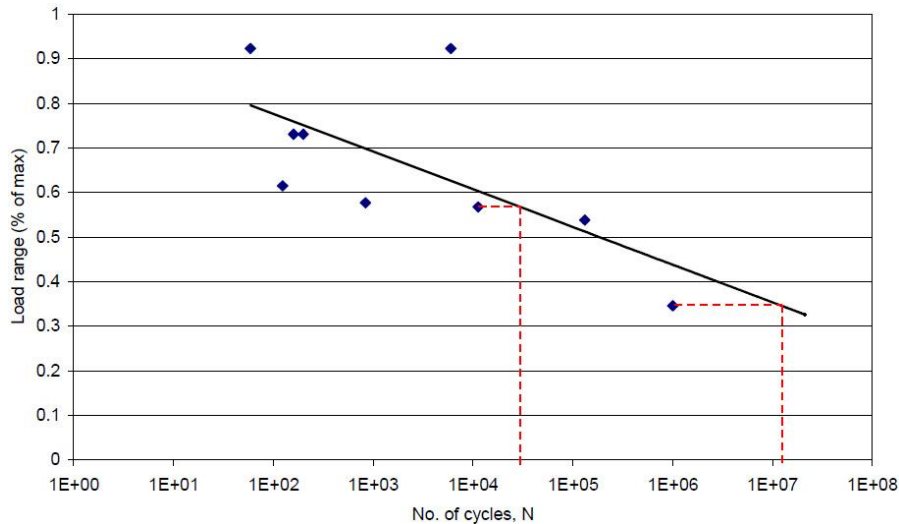

Fig. 6. Fatigue curve for concrete beam specimens tested.

### 3.4. The measurement of moisture absorption in concrete

A fibre-optic based humidity sensor has been developed and used for the measurement of moisture absorption in concrete. The sensor was fabricated using a fibre Bragg grating (FBG) coated with a moisture sensitive polymer. To investigate the use of this sensing technique for the detection of moisture ingress in concrete, the sensor was embedded in various concrete samples of different water to cement ratios which were then immersed in a water bath. A direct indication of the humidity level within a sample is given by the shift of the Bragg wavelength caused by the expansion of the humidity-sensitive material coated on the fibre. The sensor itself exploits the inherent characteristics of the FBG, with its operation being based on the strain effect induced in the Bragg grating, through the swelling of the polymer coating.

It was found that optical fibre based humidity sensors of this type form a basis for determining the changes in the moisture content in different concrete samples, indicating potential new applications of the sensor system to ensure the integrity of civil engineering structures in which they are used.

Due to the nature of concrete structures and their exposed environmental conditions (e.g. a bridge), corrosion can occur internally without this being evident from the outside. This is often due to the ingress of water corroding the reinforcements, which is hastened by the salts and chlorides dissolved in it. Concrete itself is made up by simply mixing cement, aggregate and water together, but its properties and strength reside in the specifics of the quantities used and the way that it is cured. The durability of concrete however lies in its ability to withstand the process of deterioration to which it is exposed. This may be due to both chemical attack and the repeated 'freeze-thaw' effects of water absorbed into the concrete.

There are three principal fluids that can enter and damage the concrete: water (pure or carrying chemicals) carbon dioxide and oxygen. They travel through the concrete primarily via the hydrated cement. The permeability is defined as the ease with which a fluid flows due to

the pressure differential while the porosity is a measure of the proportion of the total volume of concrete occupied by pores formed in the structure. If the porosity is high and the pores are interconnected, the permeability will also be high. There can however, also be diffusion and sorption of the concrete.

As tests for permeability of concrete have not been standardized, the permeability values quoted from different sources may not be readily comparable. The conditioning of concrete in service is nearly impossible as there is no generally accepted method, but this does not detract from the need to perform effective monitoring, and work undertaken here addresses this issue.

The humidity sensor scheme used in this work is based on an expansion principle, using a fibre Bragg grating (FBG). The influence of humidity on a polymer-coated FBG was first discussed by Giacarri et al. (2001), and the technique described for humidity detection was further explored by various authors (Laylor et al., 2002; Yeo et al., 2005). In summary, the humidity sensor is created by coating an optical fibre containing an FBG with a moisture-sensitive polymer that absorbs the moisture present, causing it to swell. This swelling effectively stretches the fibre and thereby causes a strain in the FBG contained with it. This consequently changes the wavelength of the reflected signal of the FBG which can be monitored using an optical spectrum analyser or any other similar wavelength-based interrogation technique. Different chemical coatings will have different response to humidity change. Polyimide was used as the coating material as a linear response is preferred.

In use, samples of concrete with a humidity sensor embedded inside were placed in water and the rate of water absorption was measured from the rate of the humidity change resulting in the concrete.

Due to the fragile nature of the fibre into which the sensitive FBG was written and the need to use it as a probe, it was appropriate to find a way to protect the sensor from damage in use in the concrete specimens examined. It was found to be best achieved by using a thin metal tube to cover the sensor and having holes drilled along each side to allow the free circulation of fluids. This

was fixed to the sensor using epoxy resin. The probes constructed could also require temperature compensation in some applications, and this could be done by monitoring the temperature (e.g. using the approach of previous work by some of the authors (Pal et al., 2004) and applying a correction, as required, for temperature changes. However, the tests reported in this study were carried out in a water bath, at controlled temperatures, to minimize the need for correction and maintain comparable conditions for the different concrete samples evaluated.

Standardized cylindrical samples of concrete were made with a diameter of 100 mm and depth 100 mm (Fig. 7(a)). They were cast with a 4 mm diameter hole at the centre, with a depth of 80 mm into which the sensor could be placed. The mix was manufactured using ordinary Portland cement (OPC) CEM-I 42.5 conforming to BS EN 197 Part 1 (BS EN 197-1:2000) manufactured by Lafarge (previously Blue Circle Cement Ltd.). The mix designs of the specimens were based on the guidelines from the BRE (Building Research Establishment) in the

UK (BR106:1988) and have a mix proportion ratio of 1:2:2 for cement, fine and coarse aggregate. Sharp sand with a maximum coarse size of 5 mm was used as the fine aggregate and river gravel with a maximum coarse size of 10 mm was used as the coarse aggregate. To allow for different response time in saturating a specimen, three different mixes were made, with water/cement (w/c) ratios of 0.5, 0.6 and 0.7 respectively. The concrete cylinders were removed from their casts after a period of 24 hours, after which they were left to cure in a water tank for 28 days at  $\sim 20^{\circ}\text{C}$  and finally, removed and left to dry under laboratory conditions with an average temperature of  $16^{\circ}\text{C}$  for approximately one month.

To obtain comparative data, concrete cubes of dimensions 100 mm x 100 mm x 100 mm were cast from each mix to determine the average mix strength. Four cubes from each mix were cast and their compressive strengths after 28 days were measured using a compression test machine. Data from this test are shown in Table 1. For each test, a sample was set up with the probe placed in the centre of the concrete cylinder (Fig. 7(b)).

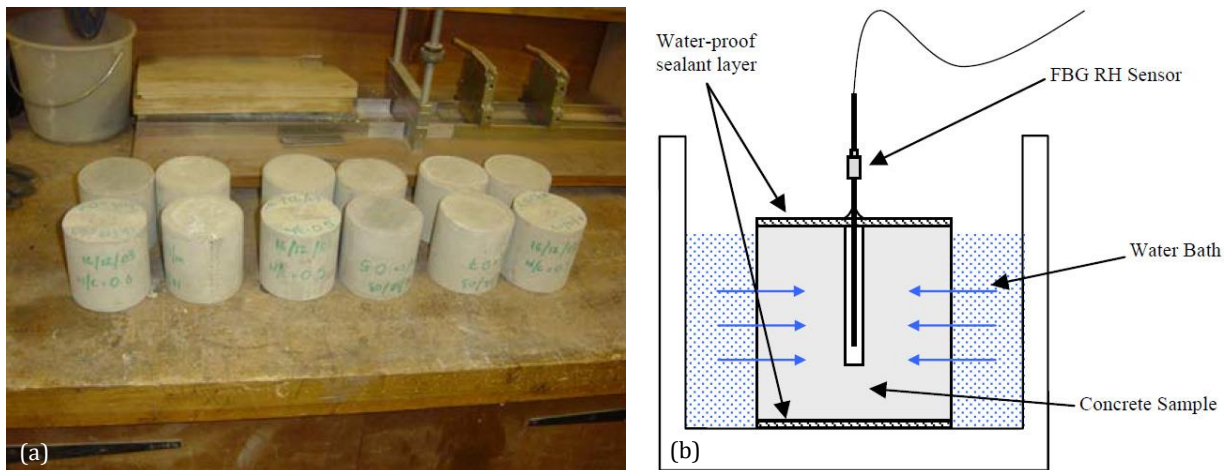

**Fig. 7.** a) Standardized cylindrical concrete samples of different water/cement ratio.  
b) Schematic of a concrete sample with a RH sensor in the water bath.

**Table 1.** Compressive strength of the concrete samples of different water/cement ratios.

Mixture (Water/Cement Ratio)	Sample	Compressive Strength (N/mm <sup>2</sup> )	Average
0.5	a	36.4	36.5
0.5	b	36.9	
0.5	c	36.5	
0.5	d	37.3	
0.6	a	25.6	26.9
0.6	b	27.7	
0.6	c	27.1	
0.6	d	27.3	
0.7	a	14.1	14.4
0.7	b	14.3	
0.7	c	14.8	
0.7	d	14.3	

Results for a series of humidity measurements, which show the response of the same sensor to different samples (pre-conditioned at different temperature and drying duration) when immersed in water bath, are shown in Figs. 8-11. This investigation of the concrete samples, through tests with the probe itself was carried out to determine its reaction to the change of moisture content within the concrete.

In summary, it can be clearly seen that from this laboratory study, fibre optic based humidity sensors can be used effectively to monitor moisture changes in concrete. It has been shown through the data produced using several different concrete samples subjected to water ingress that concrete can be monitored effectively in this way.

**3.5. Bridge monitoring using an optical fibre monitoring system**

Mjosundet Bridge is located in Aure, about 50 kilometres north of Kristiansund on the west coast of Norway and in the County of More and Romsdal. The bridge is a five span continuous composite bridge, Figs. 12 and 13. It is practically symmetrical with two end spans of 41m, two intermediate spans of 82m and a centre span of 100m giving a total length of 346m. Both ends are supported on concrete abutments with bearings providing free movement in the horizontal direction. Piles support the two central columns (axis 3 and 4) and the intermediate columns are founded directly on to rock. All connections between the bridge deck and columns are monolithic.

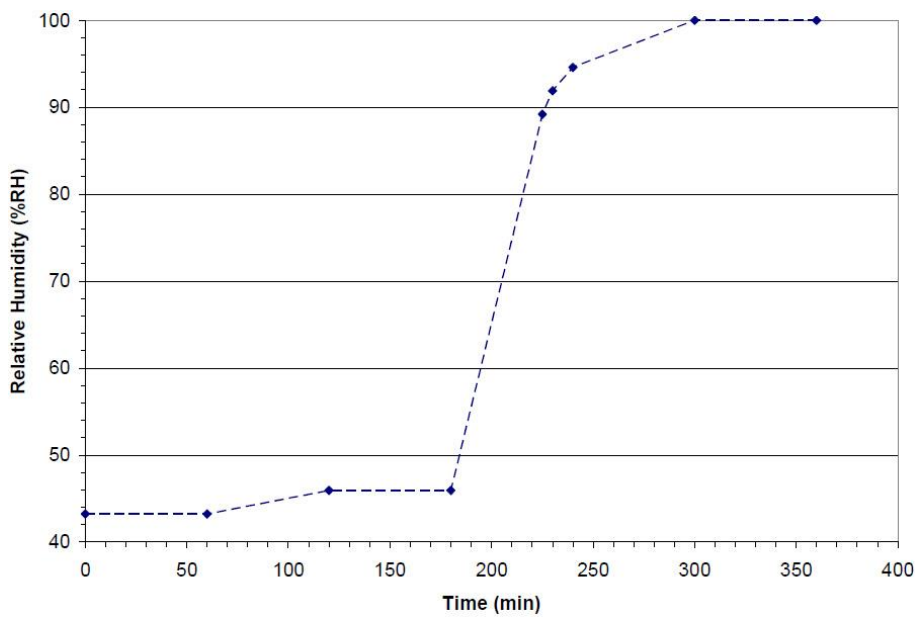

**Fig. 8.** Sample with w/c ratio of 0.6, oven dried at 80°C for 24 hours.

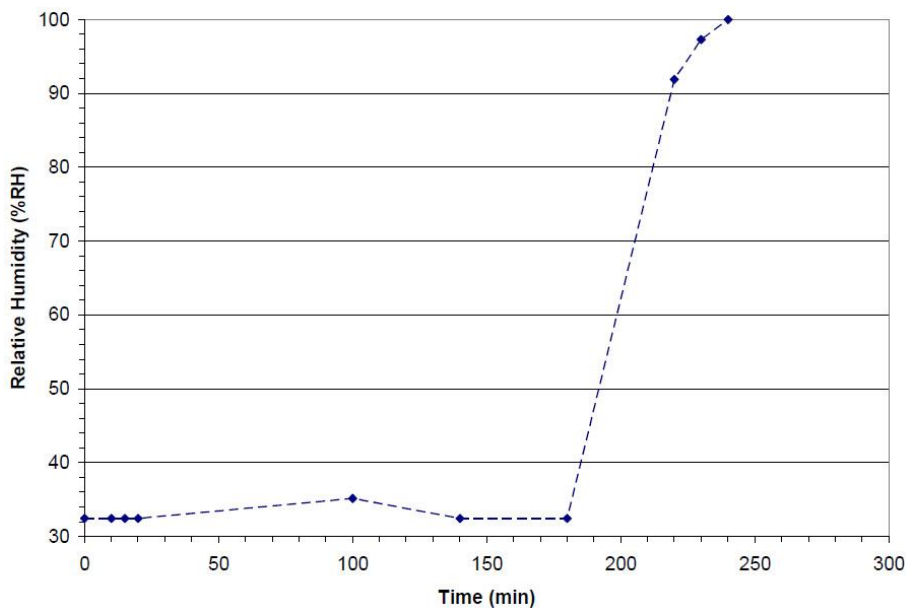

**Fig. 9.** Sample with w/c ratio of 0.7, oven dried at 80°C for 24 hours.

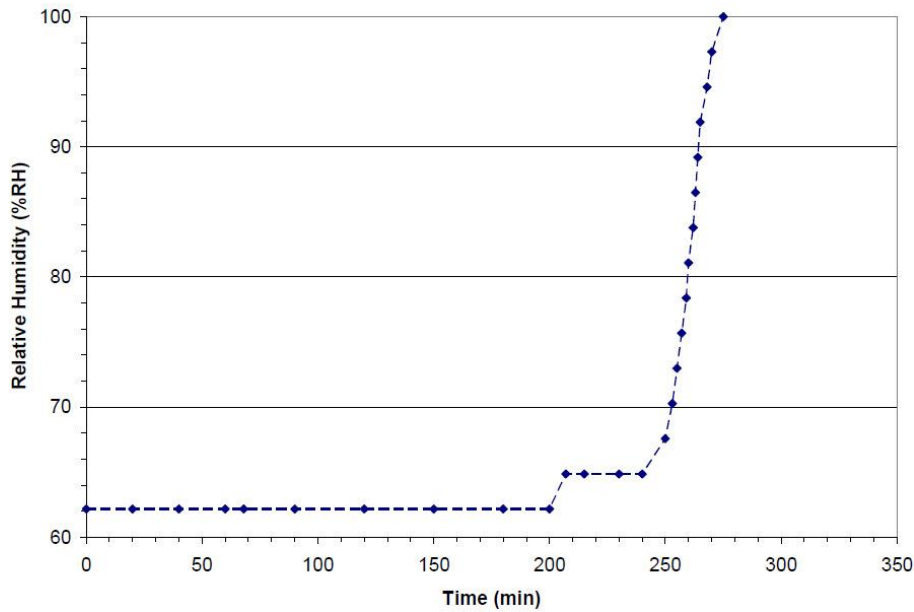

**Fig. 10.** Sample with w/c ratio of 0.5, oven dried at 95°C for 48 hours.

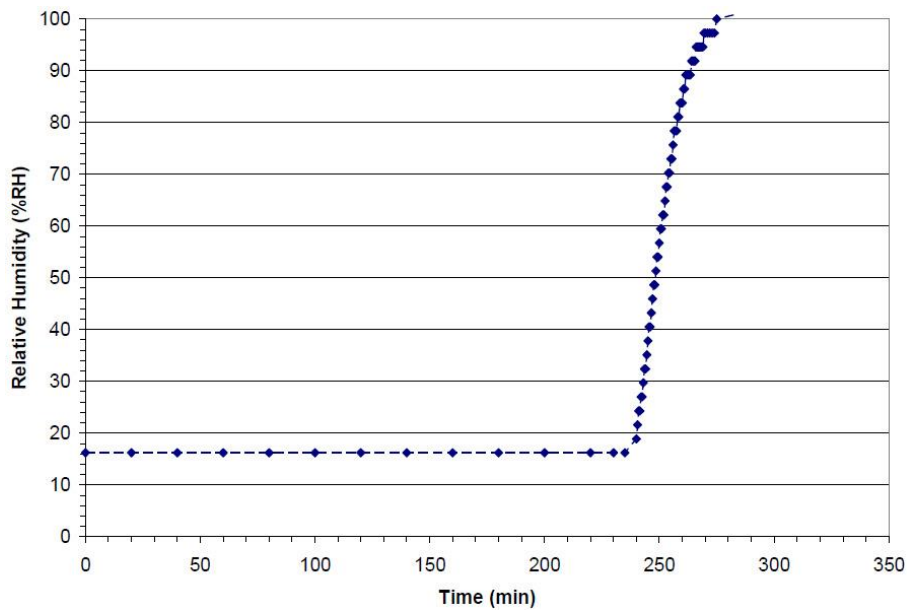

**Fig. 11.** Sample with w/c ratio of 0.7, oven dried at 95°C for 48 hours.

The deck is made of concrete, fixed with shear connectors to the top flanges of the steel box. The concrete deck is approximately 9.1 m wide and 0.3-0.4 meters thick, while the steel box varies in height from about 2.5 meters to about 4.2 meters (Fig. 14). The bottom plate, webs and flanges of the steel box all have various thicknesses (14-60 mm). The concrete deck is not visible inside the box-girder as it was cast on corrugated plate permanent formwork, supported on the steel flanges.

The construction of a model of Mjosundet with a section scale of one-fifth and length scale of one-twentieth has been completed, Fig. 15. For the purpose of the laboratory model, only the spans between sections 3 and 5 of Mjosundet were modeled. These are the central and one adjacent side spans, with the central span being the longest. This structure was successfully used to test and

implement the hardware and software for the acquisition of data. The structure was tested under a series of static and cyclic load tests within the elastic range to strain levels equivalent to those expected from the field trial.

It was considered important to provide a comparison with existing strain measuring techniques with more recently developed of optical fibre monitoring techniques. Two systems were, therefore, assembled that would run as a single unit during the field trial tests. The first system was an electrical (ERSG) system used to monitor the strain gauges that were attached to the structure. The second system was the optical fibre based fibre Bragg grating (FBG) system, which had been specifically developed to be capable of monitoring up to 100 sensors. In order to provide further information for the strain measurements, a separate finite element study was conducted.





Fig. 12. Mjosundet Bridge used for the field trials.

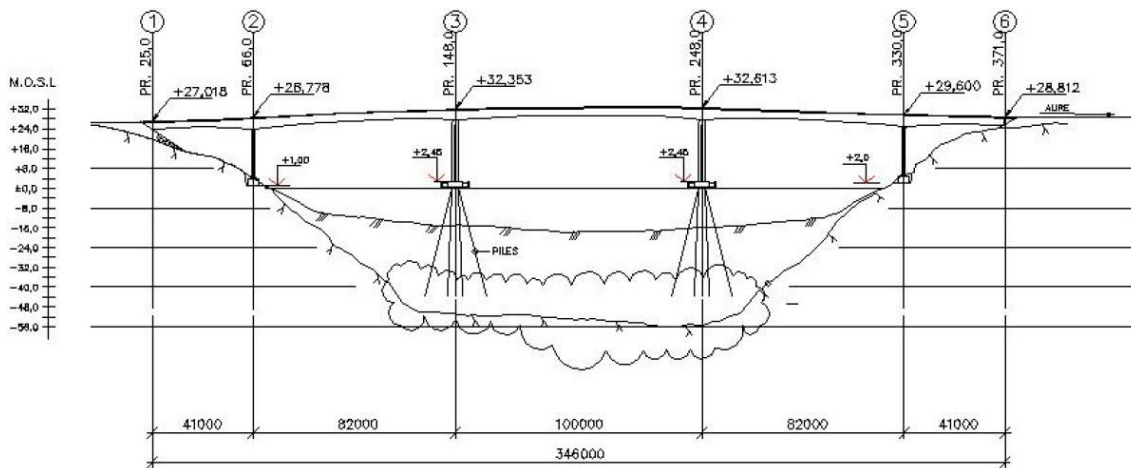

Fig. 13. Drawing of bridge with axis and profile numbering.

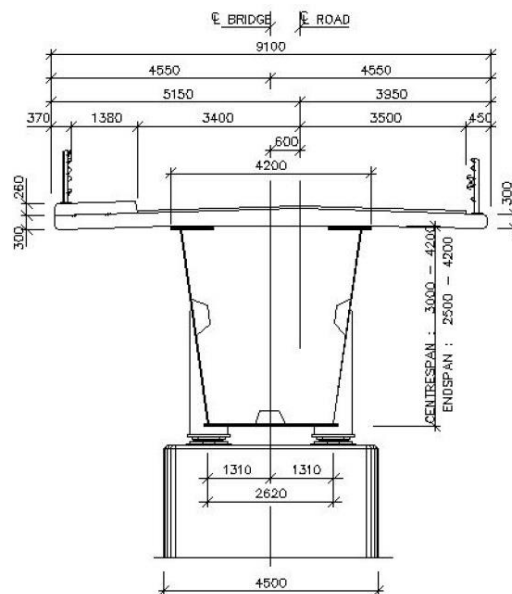

Fig. 14. Typical cross-section of bridge.



Fig. 15. Large-scale bridge model in laboratory at City University.

The bridge was instrumented on two cross sections with electrical resistance strain gauges (ERSG's) and fibre optic Bragg grating sensors (FBG's). The placement of the instrumentation was determined by a finite element analysis in order to provide guidance to the most effective positions. These positions were determined as having the highest strains within the steel structure, which would then be used within a fatigue analysis. This was a primary objective of the research, rather than aiming to describe the performance of the whole structure. Three locations at each section within the structure were monitored in order to assess the bending strains at the centre of the bridge and the shear strains close to one of the supports of the middle span of the bridge. The three monitored locations near the support were placed 0.5, 1.0 and 1.5 m measured up from the lower flange. The remaining three monitored locations were placed at centre of the bridge with two being on the bottom flange (0.4 m and 0.8 m from the web) of the bridge and the other placed at the lower edge of the web, 0.22 m up from the flange. The arrangement of the instrumentation was such that an ERSG could be used to verify the measurements of a corresponding FBG and to calibrate the finite element model. The remaining FBG's would then be assessed using the finite element model. The duplication of sensors at any position on the structure was conducted in order that the repeatability of any sensor measurements could be determined as well as providing redundancy within the data set.

Field trial testing was conducted on three individual occasions, together with continuous monitoring between each test. Each of the individual field trials consisted of a number of static and dynamic tests where the structure was subjected to loads from a number of parked or moving vehicles, respectively. The static tests consisted of three loading states where the structure was subjected to maximum sagging and hogging moments and maximum shear forces up to the design load levels. A series of discrete load and no-load events allowed data to be recorded continuously for the test and easily processed afterwards. During the dynamic tests, the vehicle was driven across the structure at a steady

velocity. A number of these tests also involved the vehicle being driven over a plank in order to induce shock vibrations and, hence record data during natural frequency oscillations.

#### 4. Comparison of Theoretical and Acquired Data

Fig. 16 shows a comparison of data acquired from both measurement systems with that obtained from the finite element analysis. A comparison is made for one load case and each figure represents the longitudinally aligned sensors from one of the monitored cross sections.

From Fig. 16, it is clear to see the bending of the structure with the neutral axis located approximately 2.5 m to 2.75 m above the lower flange of the structure. The data from the two measuring systems agree well with each other, which are slightly underestimated by the finite element analysis. However, since the gradients of these lines are equivalent it has been assumed that this difference is due to an axial force in the structure during the load test caused by fixture of the deck between the columns. The difference in the data is none the less very similar.

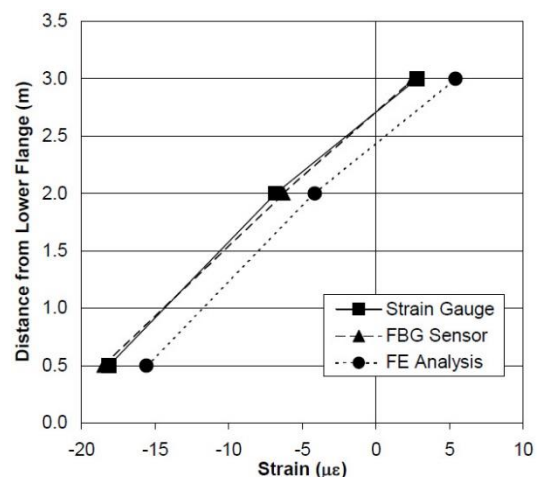

Fig. 16. Comparison of data at support location (high shear loads).

## 5. Conclusions

FBG and fluorescence-decay optical fibre based sensor systems have been developed and assessed for the monitoring of the structural integrity of civil engineering structures. The development of suitable surface and embedment techniques and protection systems for using optical fibre sensors in the field has been developed and validated using concrete cylinder and reinforced concrete beam tests. The sensors have been subjected to static, fatigue and thermal loading within reinforced concrete test structures and have shown excellent results throughout. The sensors attached directly to structures have correctly measured strain and temperature to  $\pm 1$  microstrain and  $\pm 2^\circ$  centigrade, respectively and dynamic strains of approximately 3000 microstrain whilst monitoring fatigue loading of reinforced concrete beams. The sensors have also monitored the stress-strain response of concrete specimens subjected to various environmental conditions. The results achieved indicate that the optical fibre probes are robust and can withstand large and sudden changes in the load applied to the test structure.

A particular interesting development has been the application to the measurement of moisture ingress in to concrete. This is the mechanism of chloride attack and a probe has been developed to develop humidity change in concrete.

The successful application of FBG sensors for monitoring the short and long term loading of bridge structures has been conducted with continuous data being recorded for a period of 17 months in one application.

The amount of data acquired during the course of this programme has been enormous and it would be impossible to present all of it here. It is, however, possible to summarise the data. A comparison between the two types of sensor system (ERSG and OFS) was used to assess the performance of the optical fibre based monitoring techniques.

For sensed locations on the field trial structure where there were ERSG and OFS sensors at the same location (a total of 10 sensor points), a comparison between the two types of sensor was possible with the following results:

- $1.2\mu\epsilon$  average difference between ERSG & OFS for 10 sensors over 4 tests.
- $11.9\mu\epsilon$  standard deviation of difference for same sampling batch.

Similarly, a comparison of all of the sensors from two field trial tests conducted 13 months apart is possible after factoring the data to account for differences in the load levels, which shows:

- $7.2\mu\epsilon$  average change for 28 OFS sensors over the 2 tests conducted 13 months apart.
- $18.8\mu\epsilon$  standard deviation of the change for same sampling batch.
- $-4.3\mu\epsilon$  average change for 8 ERSG sensors over the 2 tests conducted 13 months apart.
- $7.6\mu\epsilon$  standard deviation of the change for same sampling batch.

The use of optical fibre based technologies within civil engineering has been proven to be of use for further investigations. Sensors are currently being developed to measure the ingress of moisture and chlorides into concrete structures that can ultimately lead to an increased

understanding of the behaviour of the materials involved and their resistance to chemical attack. Sensors are also being used to determine the effectiveness of repairs for concrete structures and members.

## Acknowledgements

The funding for this activity has been through several European and national research programmes from the European Commission and EPSRC funding bodies. The research has been conducted in collaboration with the following institutions:

- City University - Electrical, Electronic and Information Engineering, EM Technology (UK).
- Cranfield University (UK), University of Kent (UK), Norwegian Public Roads Authority.
- Oceanographic Company of Norway (OCEANOR), ACREO AB (SE) and ETANE S.A. (GR).

## REFERENCES

- Betz D, Staudigel L, Trutzel MN, Schmuecker M, Huelsmann E, Czernay U (2002). Test of a fibre Bragg grating sensor network for commercial aircraft structures. *Conference Proceedings Optical Fibre Sensors (OFS 15)*, Portland USA, 55-58.
- BR106 (1988). Building research establishment report. Design of normal concrete mixes. Revised Ed.
- BS EN 197-1 (2000). Cement composition, specifications and conformity criteria for common cements.
- Ferdinand P, Ferragu O, Lechien JL, Lescop B, Marty V, Rougeault VS, Pierre G, Renouf C, Jarret B, Kotrotsios G, Neuman V, Depeursings Y, Michel JB, Uffelen MV, Verbandt Y, Voet MRH, Toscano D (1994). Mine operating accurate stability control with optical fibre sensing and Bragg grating technology. *The Brite Euram Stabilis Project Proceedings, SPIE 2360*, 162-166.
- Giaccari P, Limberger HG, Kronenberg P (2001). Influence of humidity and temperature on polyimide-coated fiber Bragg gratings. *Proceedings Tends in Optics and Photonics Series: Bragg gratings, photosensitivity, and poling in glass waveguides*, 61, BFB2.
- Grattan KTV, Meggitt BT (2000). Optical Fibre Sensor Technology Fundamentals. Kluwer Academic Publishers, Dordrecht, Netherlands.
- Grattan KTV, Meggitt BT (2000). Optical Fibre Sensor Technology Advanced Applications-Bragg Gratings and Distributed Sensors. Kluwer Academic Publishers, Dordrecht, Netherlands.
- Laylor M, Calvert S, Taylor T, Schulz W, Lumsden R, Udd E (2002). Fiber optic grating moisture and humidity sensors. *Proceedings Smart Structures and Materials: Smart Sensor Technology and Measurement System*, 4694, 210-217.
- Maurin L, Boussoir J, Rougeault S, Bugaud M, Ferdinand P (2002). FBG-based smart composite bogies for railway applications. *Conference proceedings optical fibre sensors (OFS 15)*, Portland USA, 91-94.
- Measures RM, Alavie AT, Maaskant R, Ohn M, Karr S, Huang S (1995). A structurally integrated Bragg grating laser sensing system for carbon fibre prestressed concrete highway bridge. *Smart Materials and Structure*, 4, 20-30.
- Ning YN, Meldrum A, Shi WJ, Meggitt BT, Palmer AW, Grattan KTV, Li L (1998). Bragg grating sensing instrument using a tunable Fabry-Perot filter to detect wavelength variations. *Measurement Science Technology*, 9, 599-606.
- Pal S, Sun T, Grattan KTV, Wade SA, Collins SF, Baxter GW, Dussardier B, Monnom G (2004). Strain-independent temperature measurement using a type-I and type-IIA optical fiber Bragg grating combination. *Review of Scientific Instruments*, 75, 1327-1331.
- Yeo TL, Sun T, Grattan KTV, Parry D, Lade R, Powell BD (2005). Polymer-coated fiber Bragg grating for relative humidity sensing. *IEEE Sensors Journal*, 5, 1082-1089.