

Implementation of Wireless Sensor in Coal Mine Safety System

R.MUTHAIYAN¹, V.G.RAJARAMYA², A.BILOMIN RAMYA³
Asst. Professor / Department of ECE, ^{1,2}, M.E VLSI ³
University College of Engineering, Thirukkuvalai, India¹
SRV Engineering College, Sembodai, Vedaranyam, India^{2,3}

ABSTRACT: The foremost critical task for coal mine is of keeping track of miners spread out across a large mining areas .It becomes even difficult when mine tunnels collapse. Many mines use a radio system to track miners, but when a collapse occurs, the base stations connected by a thin wire often are rendered useless. In this project to overcome the demerits of radio system we used wireless technology for tracking the miners. The transceivers communicate with base stations through LIFI module. In addition of tracking the location of miners we also include sensors such as temperature & humidity to intimate the base station & miners when some atmosphere changes occur. Mine operators are now able to monitor the real-time locations of each miner to better pinpoint their locations in the event of an emergency.

1.1GENERAL

Wireless network is one of the hottest topics in mobile computing. Everything has an opinion on the state of the third generation (3G) wireless networks, the effect of Bluetooth of personal networks, and which wireless local area network technology will dominate the market. Even though not all mobile applications require wireless connectivity, there is no doubt that wireless technology is one of the main driving forces behind mobile computing. Wireless networks serve many purposes. In some cases they are used as cable replacement, while in order cases they are used to provide access to corporate data from remote location. Much of the industry type surrounds third generation wide area networks that provide broadband wireless connectivity to users on a national basis. These networks are now commercially available in most generating excitement. As users carry around multiple devices a need arises for an easy, effective way for them to communicate.

For the purpose of discussion, wireless network will be divided into two broad segments: short-range and long-range. Short-range wireless pertains to networks that are confined to a limited area. This applies to local area networks, such as corporate building, school campuses, manufacturing plants or homes, as well as personal area networks where portable computers typically operate over unlicensed spectrum recovered for industrial, scientific, medical usage. The available frequencies differ from country .the most common frequency band is at 2.4 GHZ, which is available across most to the globe. Other band at 5GHZ and 40GHZ are also often used.

Long ranges networks continue where LANs and connectivity is typically provided by companies that sell the wireless connectivity as a service. These networks span large area such as metropolitan area, a state or province, or an entire country. The goal of long-range network is to provide wireless coverage globally. The most common long range network is wireless wide area network (WWAN). When true global coverage is required, satellite network are also available.

PROPOSED SYSTEM

In this project to overcome the demerits of radio system we used wireless technology for tracking the miners. The transceivers communicate with base stations through LIFI module. In addition of tracking the location of miners we also include sensors such as temperature & humidity to intimate the base station & miners when some atmosphere changes occur. Mine operators are now able to monitor the real-time locations of each miner to better pinpoint their locations in the event of an emergency. In Li Fi network at receiving side we use the photo detector sensor will be used.

7.1BLOCK DIAGRAM

7.1.1 MINE SECTION:

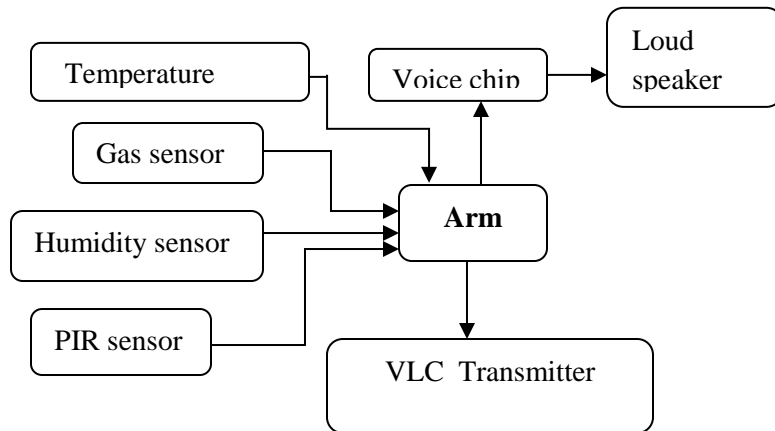

Fig 7.1.1.1 Proposed Block Diagram for Mine Section

SERVER SECTION

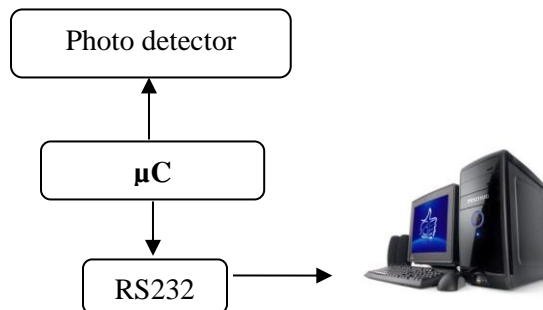

Fig 7.1.2.1 Proposed Block Diagram for Server Section

7.1.3 Sensors used:

- Temperature Sensor
- Humidity sensor
- Gas sensor
- PIR sensor

7.2 LI-Fi:

LiFi is a new paradigm for short range wireless technology to provide unprecedented connectivity within a localized data-centric environment. Li Fi is a transmission of data through illumination, sending data through a red light bulb that varies in intensity faster than human eye can follow. This sort of communication can be called as Visible light communication (VLC). Using this technique, the user can transmit the data through light from one device to another.

7.2.1 PHOTO DETECTOR

An Avalanche Photodiode (APD) provides higher sensitivity than a standard photodiode. It is ideal for extreme low-level light (LLL) detection and photon counting. Offered in Silicon or InGaAs materials, these devices provide detect from 400 nm - 1100 nm. Multiple configurations are available to provide a wide range of sensitivity and speed options.

Advantages of this system

1. No interference on RF signal
2. Illumination and communication
3. Optical output is varied at extremely high speed
4. Unutilized electromagnetic spectrum
5. Can be used in more environment
6. No health problems

LI FI

3.1 INTRODUCTION

LiFi is a new paradigm for short range wireless technology to provide unprecedented connectivity within a localized data-centric environment. Li Fi is a transmission of data through illumination, sending data through a red light bulb that varies in intensity faster than human eye can follow. This sort of communication can be called as Visible light communication (VLC). Using this technique, the user can transmit the data through light from one device to another. Li-Fi technology works on a simple digital principle which is nothing but a led is ON a digital data 1 can be transmitted and if it is OFF digital data 0 can be transmitted. So, in this project work we are going to switching the LEDs very quickly. These fast switching can be achieved by PWM technique to transmit digital data stream containing strings.

To acquire this, we are programming the microcontroller to vary the duty cycle of the PWM signal which has the task of regulating the current in the LED. The biased current is fed to LED driver unit. The power of LED is varied according to the waveform of data signal. At the receiver side photodiode sensor produces a current proportional to the received instantaneous power. From this data can be filtered and it can be displayed on PC.



Fig 3.1.1 Real Time Usage of LiFi

3.2 Technology Details

It is a 5G visible light communication system that uses light from light-emitting diodes (LEDs) as a medium to deliver networked, mobile, high-speed communication in a similar manner as Wi-Fi. Li-Fi could lead to the Internet of Things, which is everything electronic being connected to the internet, with the LED lights on the electronics being used as Li-Fi internet access points. The Li-Fi market is projected to have a compound annual growth rate of 82% from 2013 to 2018 and to be worth over \$6 billion per year by 2018.

Visible light communications (VLC) works by switching bulbs on and off within nanoseconds, which is too quickly to be noticed by the human eye. Although Li-Fi bulbs would have to be kept on to transmit data, the bulbs could be dimmed to the point that they were not visible to humans and yet still functional.[8] The light waves cannot penetrate walls which makes a much shorter range, though more secure from hacking, relative to Wi-Fi.

3.2.1 Advantages of Li-Fi:

Li-Fi has the advantage of being useful in electromagnetic sensitive areas such as in aircraft cabins, hospitals and nuclear power plants without causing electromagnetic interference. Both Wi-Fi and Li-Fi transmit data over the electromagnetic spectrum. But whereas Wi-Fi utilizes radio waves, Li-Fi uses visible light. While the US Federal Communications Commission has warned of a potential spectrum crisis because Wi-Fi is close to full capacity, Li-Fi has almost no limitations on capacity. The visible light spectrum is 10,000 times larger than the entire radio frequency spectrum. Researchers have reached data rates of over 10 Gbit/s, which is more than 250 times faster than superfast broadband. Li-Fi is expected to be ten times cheaper than Wi-Fi. Short range, low reliability and high installation costs are the potential downsides.

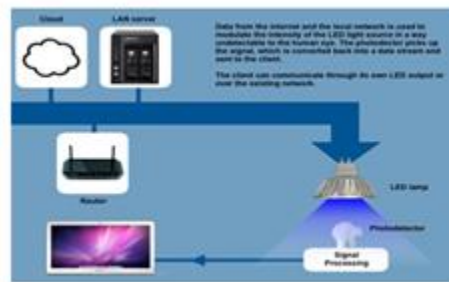

Fig 3.2.1.2 How LiFi works

3.3 Internet Connection Through Li-Fi LED Light Bulbs



Fig 3.3.1 LiFi LED bulbs

While I am someone who could possibly be called a techno-phobe, I found this news from China interesting in its future possibilities. Scientists in China are succeeding in replacing traditional Wi-Fi radio traffic with Li-Fi, a system that uses the light signals from an LED light-bulb. Li-fi, short for "light-fidelity", back in 2011. Now The Shanghai Institute of Technical Physics has developed new hardware that uses Li-Fi for high-speed data which are almost ready for market.

Chinese scientists have reportedly been able to use a single one-watt LED light-bulb with a signal modulation chip to send data to four PCs at 150Mbps. As an alternative to radio transmissions, it has several advantages over wi-fi. It is cleaner and it's greener. Light is much more energy-efficient than radio, and has potentially 10,000 times the bandwidth to transmit information. Wherever there is an LED light bulb, there is an Internet signal. If you turn off the light, there's no signal. The signal will be cut off. Already, ten Li-Fi kits, using one LED light bulb, are on display at this month's China International Industry Fair, which began on November 5. With a specially-designed receiving station, the PCs were able to connect to the LED bulb. The number of devices that already use LEDs - including the flashbulbs on mobile phone and cameras - means that in theory, the infrastructure already partly exists for Li-Fi communication. Li-Fi is not without its drawbacks: it is dependent on light, so cannot be used in the dark, but have been connected to nearby laptops with Ethernet. Its size is a problem. Not what you would call portable, the first model is about the size of a video game console. Over the next 5 years, scientists will work on miniaturizing components and improving Li-Fi coverage. Considering only 18 months have been spent getting this far in the development of LI-Fi it will be interesting to see the future models.

3.4 Avalanche Photodiodes:



Fig 3.4.1 avalanche photodiodes

An Avalanche Photodiode (APD) provides higher sensitivity than a standard photodiode. It is ideal for extreme low-level light (LLL) detection and photon counting. Offered in Silicon or InGaAs materials, these devices provide detectivity from 400 nm - 1100 nm. Multiple configurations are available to provide a wide range of sensitivity and speed options.

Products offered include:

- High-volume, cost effective silicon APDs for Range Finding and Laser Meter applications.
- Large area, UV-enhanced APDs for Molecular Imaging (PET).
- Long wavelength enhanced APDs for Analytical Applications.
- Multi element and quadrant APDs for Analytical Instruments.
- Standard, high performing APDs for Industrial applications.
- Hybrid Modules for easy implementation into high performing Instruments.

The use of APDs instead of PIN photo detectors will result in improved sensitivity in many applications. In general, APDs are useful in applications where the noise of the amplifier is high — i.e., much higher than the noise in the PIN photo detector.

RESULT

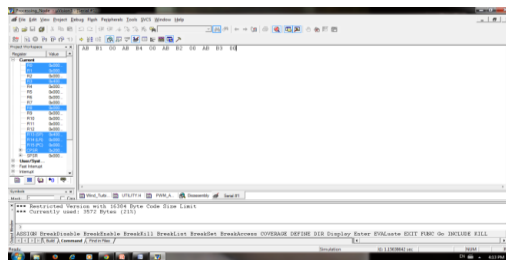

CONCLUSION

Traditional mine security system can be effectively replaced by the surveillance and safety system proposed in the paper. A large area and more depth inside hazardous underground mines are now covered and potential accidents can be controlled effectively. The system combined with Li-Fi wireless data transmission technology with modern small size sensors.

REFERENCES

- [1] L. G. Stolarczyk, "Emergency and operational low and medium frequency band communications system for underground mines," *IEEE Trans. Ind. Appl.*, vol. 27, no. 4, pp. 780–790, Jul./Aug. 1991.
- [2] L. G. Stolarczyk and H. Bobroski, "Medium frequency vehicular control and communication systems for underground mines," in *Proc. IEEE Veh. Technol. Conf.*, May 21–23, 1984, pp. 316–321.
- [3] H. Dobroski, Jr. and L. G. Stolarczyk, "Control and monitoring via medium-frequency techniques and existing mine conductors," *IEEE Trans. Ind. Appl.*, vol. IA-21, no. 4, pp. 1087–1092, Jul. 1985.
- [4] L. G. Stolarczyk, *A Medium Frequency Wireless Communication System for Underground Mines*, A.R.F. Products, Inc., Raton, NM, USA, A mining contract research report, Contract HO308004, pp. 20–22, pp. 83–103. [Online]. Available: <http://www.cdc.gov/niosh/mining/pubs/pdfs/h0308004-3.pdf>
- [5] L. G. Stolarczk, M. Sepich, and K. Smoker, *A Medium Frequency Wireless Communication System for Underground Mines*, A.R.F. Products, Inc., Raton, NM, USA. [Online]. Available: <http://www.cdc.gov/niosh/mining/pubs/pdfs/h0308004-2.pdf>
- [6] M. D'Amore and M. Sabrina, "Simulation model of a dissipative transmission line above a lossy ground for a wide-frequency range—Part I: Single conductor configuration," *IEEE Trans. Electromagn. Compat.*, vol. 38, no. 2, pp. 127–138, May 1996.
- [7] D. Hill and J. Wait, "Excitation of monofilar and bifilar modes on a transmission line in a circular tunnel," *J. Appl. Phys.*, vol. 45, no. 8, pp. 3402–3406, Aug. 1974.
- [8] J. R. Carson, "Wave propagation in overhead wires with ground return," *Bell Syst. Tech. J.*, vol. 5, pp. 539–553, 1926.
- [9] H. K. Sacks and R. L. Chufo, "Medium frequency propagation in coal mines," in *Proc. 4th WVU Conf. Coal Mine Electrotechnol.*, Morgantown, WV, USA, Aug. 2–4, 1978, pp. 27-1–27-12.
- [10] P. Degauque, G. Courbet, and M. Heddebaut, "Propagation along a line parallel to the ground surface: Comparison between the exact solution and the quasi-TEM approximation," *IEEE Trans. Electromagn. Compat.*, vol. EMC-25, no. 4, pp. 422–427, Nov. 1983.
- [11] A. Agrawal, K. Lee, L. Scott, and H. Fowles, "Experimental characterization of multiconductor transmission lines in the frequency domain," *IEEE Trans. Electromagn. Compat.*, vol. EMC-21, no. 1, pp. 20–27, Feb. 1979.
- [12] J. Volakis, *Antenna Engineering Handbook.*, 4th ed. New York, NY, USA: McGraw-Hill, 2007, pp. 51-3–51-43.
- [13] G. R. K. Shevgaonkar, *Transmission Lines and EM Waves*. Mumbai, India: Department of Electrical Engineering, IIT, Jan. 8, 2008, ser. On- Line Lecture Series.

[14] Transmission Lines. [Online]. Available: <http://www.ece.msstate.edu/~donohoe/ece4333notes2.pdf>

[15] T. S. Cory, Electromagnetic Propagation in Low Coal Mines at Medium Frequencies, Rep. Collins Commun. Switch. Syst. Div., Commercial Telecomm. Group, Cedar Rapids, IA, USA, Contract No. H0377053.

[16] R. Lagace, A. Emslie, and M. Grossman, Modeling and Data Analysis of 50 to 5000 kHz Radio Wave Propagation in Coal Mines, Supplement to Final Report, Arthur D. Little, Inc., Boston, MA, USA, USBM contract HO346045. [Online]. Available: <http://www.cdc.gov/niosh/mining/pubs/pdfs/h0346045-2.pdf>



R.MUTHAIYAN
Asst.Prof/Department of ECE
University College of Engineering,
Thirukkuvilai, India



V,G.RAJARAMYA
Asst.Prof/Department of ECE
SRV Engineering College, Sembodai, Vedaranyam, India



A.BILOMIN RAMYA
M.E VLSI