

Embedded based Controller for Induction Generator

Rupinder kaur¹, Shruti Aggarwal²

M.Tech Research Scholar¹, Assistant Professor²

Department of Computer Science and Engineering

Sri Guru Granth Sahib World University, Fatehgarh Sahib,
Punjab, India

Abstract--With faster rate of depletion of fossil fuels the world has now started to greatly depend on renewable sources of energy. Wind energy is undoubtedly one of the most effective weapons to handle the situation. In this paper efforts have been taken to optimize the wind energy generation by induction generator using an embedded based controller. This paper involves a controller design which amalgamates two key functions viz. automatic voltage regulation and frequency control. The automatic voltage regulator is incorporated with the help of flux control. The proposed controller regulates the excitation current of the induction generator to regulate the generated three phase voltage. The reactive power balance of the system can be maintained within tolerable limits by using VAR condensers which is switched accordingly by the embedded controller. The frequency control can be implemented by adjusting the wind turbine pitch according to the wind inrush by measuring the wind speed. The controller provides control pulses to actuate stepper motor suitably which drives the blade to orient itself appropriately. A simulation model is also developed to illustrate this control strategy. The wind is simulated by considering the average wind characteristics.

I. INTRODUCTION

The use of induction machine as a generator has become more and more popular. Induction generators are widely used for non conventional energy and have an advantage of lower cost, higher reliability, rugged and simple construction, reduced maintenance and so on. An induction machine can be made to operate as an isolated ac generator by supplying the necessary exciting or magnetizing current from capacitors connected across the terminals of the inverter which is connected across the machine. In an isolated application a 3-phase induction generator operates in self excited mode. In self excited induction generator the excitation current is supplied by the capacitor.

In this paper a controller has been proposed which compensates for a variation in output voltage and generated frequency. The static VAR sources make it possible to consider the induction generator as an alternative for synchronous generator. The rotor of the induction generator

is driven by the wind turbine and hence can vary at any time. When the induction generator excited by the external capacitor or single capacitor is loaded, the magnitude of the generated voltage and frequency will vary with load. The terminal voltage of the induction generator is controlled using the vector control scheme. The output voltage is regulated by varying the flux in the induction generator. However the generated frequency can only be compensated by varying the rotor speed of the induction generator

II. PRINCIPLE OF OPERATION

The voltage regulated induction generator controller uses a pulse width modulated inverter to supply excitation current for induction generator. The generated voltage is regulated by controlling the current drawn by the inverter.

The dynamic generated frequency, during loading conditions, is calculated from the measured voltages. A three-axis to two-axis transformation is used in the calculation of dynamic frequency value. Here the transformation is used to simplify the calculation. In the experimental investigation the speed of the rotor was kept at a constant value by applying a speed regulator to the prime mover.

A dynamic model for the three phase induction machine can be derived from the two phase induction machine if the equivalence between two and three phases is established. The equivalence is based on the equality of the mmf produced in the two phase and three phase windings and equal current magnitudes.

Embedded system:

Embedded System is a combination of hardware and software used to achieve a single task. Embedded system simplifies the task of complex controlling equipments and accomplishes the control process with the help of a microcontroller.

Embedded systems are computer systems that monitor, respond to, or control an external environment. Environment connected to systems through sensors, actuators and other I/O interfaces. Embedded system must

meet timing & other constraints imposed on it by environment.

Embedded system overview

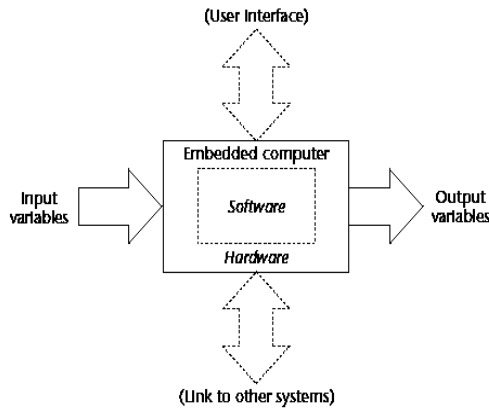

A
n
Emb

embedded system is a component within some larger system. It is contrast with general-purpose computers. **The software in the embedded system is called firmware.** An Embedded system is an intelligent firmware designed for a definite process to be achieved perfectly.

An Embedded system, in general, incorporates hardware, operating system, and peripheral devices and communication software to enable to perform the predefined functions.

In contrast to desktops that perform a variety of tasks, an embedded system performs a single, well-defined task. The system has a processor, associated peripherals, and software for a specific purpose. This is possible by programming security bit/code in a microcontroller program. The use of simple microprocessors in embedded intelligence has gradually decreased and the use of microcontroller in such an environment has not only increased but also brought in a revolutionary change. This is indeed due to integration of microprocessor and certain peripherals (including memory) on a single chip known "microcontroller". Thus, it can be thought of us as $\mu p++$. thus an embedded controller in this paper.

III. SYSTEM DESCRIPTION

A static PWM inverter is used for controlling excitation. The

The proposed system starts its excitation process from an external battery. The external battery helps to charge the capacitor and also to start the build up of flux in the core. When the generated voltage rises to a value greater than the battery voltage then the diode blocks the back flow of current to the battery.

Reference frames simplifies the dramatic simplification of the system equations. For the purpose of control it is always easy if the variables involved are of DC type. But the situation is not so as the variables involved are of alternating sinusoidal type. This complication can be overcome by having a reference frame revolving at the same angular speed as that of the sinusoidal variable. As the reference frames are moving at an angular speed equal to the angular frequency of the sinusoidal supply, then, the differential speed between them is reduced to zero, resulting in the sinusoid being perceived as a DC signal from the reference frames. Then by moving to that plane it is easier to develop the small signal equation out of the nonlinear equation at the operating point described by the DC variables.

The total stator flux of the induction generator is controlled by the d-axis stator current in the rotating or excitation reference frame. The q-axis stator current reference frame controls the active power output generated by the induction generator. Hence the flux producing currents can be independently controlled.

Overall system description

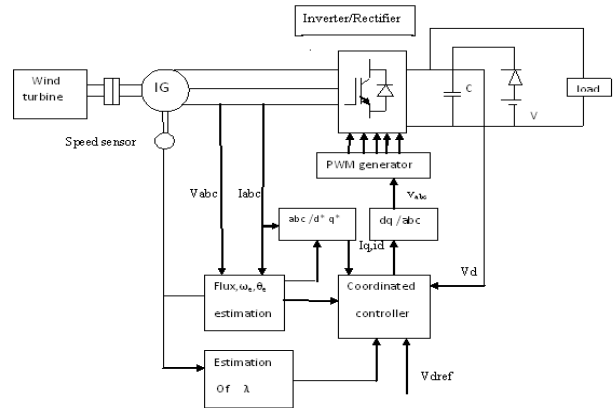

shunt connected PWM inverter has to supply only excitation

current and reactive load current. The active load current is directly supplied by the generator. The terminal voltage is regulated for varying rotor speed and changing load conditions. The reference current generated and the output current are processed by the controller and initiate the necessary pulses to the inverter.

Frequency control:

If the output to be taken is of alternating type then the frequency of the output voltage is to be kept constant .however the prime over is variable speed wind turbine. In order to maintain constant frequency sensors along with stepper motors are used which are controlled by the controller. The sensors will measure wind direction and actuate corresponding signals to the controller. The controller then drives the stepper motor so that turbine is properly directed into the wind. If the wind speed is above the cut-in value, the pitch is changed so that rotation can occur. The generator field control is activated so that a predetermined current is sent through the field of the generator. A fixed field current fixes the flux, so that E is proportional to the rotational speed n. The turbine accelerates until it almost reaches rated angular velocity. At this point the frequency of E will be about the same as that of the power grid. The amplitude of E will be about the same as V if the Generator field current is correct. Slightly variation in different frequencies will cause the phase difference between E and V to change slowly over the range of 0 to 360°. The voltage difference V_d is sensed so that appropriate control measure can be taken by controller.

SYNCHRONOUSLY ROTATING REFERENCE FRAMES MODEL

The concept of equal mmf and current magnitudes are made use of in this technique. The number of turns in the either side of the equation is cancelled leaving the current equalities. The q axis is assumed to be lagging the d axis by θ . The relationship between dqo and the abc currents is as follows:

$$\begin{pmatrix} i_{qs} \\ i_{ds} \\ i_0 \end{pmatrix} = \frac{2}{3} \begin{pmatrix} \cos \theta_c & \cos(\theta_c - 2\pi/3) & \cos(\theta_c + 2\pi/3) \\ \sin \theta_c & \sin(\theta_c - 2\pi/3) & \sin(\theta_c + 2\pi/3) \\ 1/2 & 1/2 & 1/2 \end{pmatrix} \begin{pmatrix} i_{as} \\ i_{bs} \\ i_{cs} \end{pmatrix}$$

The current i_0 represents the imbalances in the currents of the three phases and can be recognized as the zero sequence

component of the current.

$$i_{qd0} = [T_{abc}] i_{abc}$$

where

$$i_{qd0} = [i_q \ i_d \ i_0]^T$$

$$i_{abc} = [i_a \ i_b \ i_c]^T$$

and the transformation from abc to dqo variables is

$$T_{abc} = \frac{2}{3} \begin{pmatrix} \cos \theta_c & \cos(\theta_c - 2\pi/3) & \cos(\theta_c + 2\pi/3) \\ \sin \theta_c & \sin(\theta_c - 2\pi/3) & \sin(\theta_c + 2\pi/3) \\ 1/2 & 1/2 & 1/2 \end{pmatrix}$$

This transformation can also be thought of as a transformation from three (abc)axes to three new (dqo)axes; for uniqueness of the transformation from one set of axes to another set of axes, including unbalances in the abc variables requires three variables such as the dqo .the reason for this is that it is easy to convert from the three abc variables to two qd variables if the abc variables have an inherent relationship among themselves, such as the equal phase displacement and the magnitude. Therefore, in such case, there are only two independent variables in abc; the third is a dependant variable, obtained as the negative sum of the other two variables. hence a qd-to-abc transformation is unique under that there are three distinct and independent variables; hence, the third variable cannot be recovered from the two variables qd but require a third variable, such as the zero sequence component, to recover the abc variables from the dqo variables.

The speed of the reference frame is

$$\omega_c = \omega_s = \text{stator supply angular frequency/rad/sec}$$

and the instantaneous angular position is

$$\theta_c = \theta_s = \omega_c t$$

by substituting the equations ,the induction motor model in synchronous reference frames is obtained.

$$\begin{pmatrix} v_{qs}^e \\ v_{ds}^e \\ v_{qr}^e \\ v_{dr}^e \end{pmatrix} = \begin{pmatrix} R_s + L_s p & \omega_s L_s & L_m p & \omega_s L_m \\ -\omega_s L_s & R_s + L_s p & -\omega_s L_m & L_m p \\ L_m p & (\omega_s - \omega_r) L_m & R_r + L_r p & (\omega_s - \omega_r) L_r \\ -(\omega_s - \omega_r) L_m & L_m p & -(\omega_s - \omega_r) L_r & R_r + L_r p \end{pmatrix} \begin{pmatrix} i_{qs}^e \\ i_{ds}^e \\ i_{qr}^e \\ i_{dr}^e \end{pmatrix}$$

VECTOR CONTROL

Separately excited dc drives are easy to control because they independently control flux, which, when maintained constant, contributes to an independent control of active power. This is made possible with separate control of field and armature currents, which, in turn, control the field flux and torque independently. Moreover, the dc motor control requires only the control of the field or armature current magnitudes, providing simplicity not possible with ac machine control. By contrast, ac induction machine require a coordinated control of the stator current magnitudes, frequencies, and their phases, making it a complex control. Similar to the dc drives, independent control of flux and active power is possible in ac drives. The stator current phasor can be resolved, say, along the rotor flux linkages, and the component along the rotor flux linkages at every instant; is dynamic, unlike dc machine. If this is available, then the control of ac machines is very similar to that of separately excited dc machines. The requirement of phase, frequency, and magnitude control of the currents and hence of the flux phasor is made possible by inverter control. This control is known as vector control as the phasor of the rotor flux linkage is controlled. In order to implement the vector control scheme an assumption is made that the position of the rotor flux linkages phasor λ_r , is known, flux linkage is at θ from a stationary frame. The three stator currents can be transformed into q and d axes currents in the synchronous reference frames by using the transformation.

$$\begin{pmatrix} i_{qs}^e \\ i_{ds}^e \end{pmatrix} = \frac{2}{3} \begin{pmatrix} \sin \theta_f & \sin(\theta_f - 2\pi/3) & \sin(\theta_f + 2\pi/3) \\ \cos \theta_f & \cos(\theta_f - 2\pi/3) & \cos(\theta_f + 2\pi/3) \end{pmatrix} \begin{pmatrix} i_{as} \\ i_{bs} \\ i_{cs} \end{pmatrix}$$

from which the stator current phasor i_s is derived as

$$i_s = \sqrt{(i_{qs}^e)^2 + (i_{ds}^e)^2}$$

and the stator phasor angle is

$$\theta_s = \tan^{-1} \{ i_{qs}^e / i_{ds}^e \}$$

where i_{qs}^e and i_{ds}^e are the q and d axes currents in the synchronous references frames that are obtained by projecting the stator current phasor on the d and q axes respectively that the current phasor magnitude remains the same regardless of the reference frame chosen. The current phasor i_s produces the rotor flux and the active power. The component of the current producing rotor flux phasor has to be in phase with λ_r . Therefore resolving the stator current phasor along λ_r reveals that the component i_{ds}^e is the field producing component. The perpendicular component i_{qs}^e is hence the active power component. By writing the rotor flux linkages and active power in terms of these components are as follows:

$$\lambda_r \propto i_{ds}^e$$

Phasor diagram of vector controller

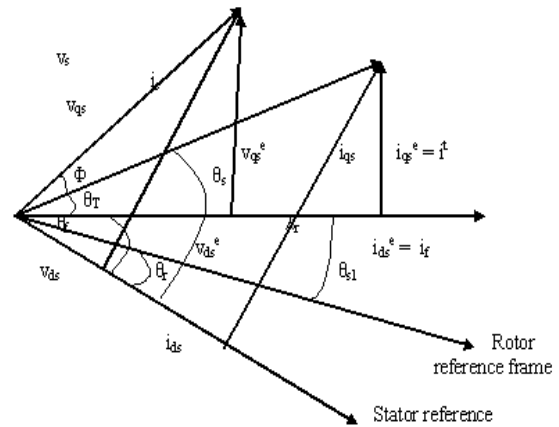

It can be seen that i_{ds}^e has only dc components in steady state, because the relative speed with respect to the rotor field is zero: the rotor flux-linkages phasor has speed equal to the sum of the rotor and slip speeds, which is equal to the synchronous speed. Orientation of λ_r amounts to considering the synchronous reference frames, and hence the flux-and active power producing components of current are dc quantities. Because they are ideal for use as control variables; the bandwidth of the computational control circuits will have no effect on processing of the dc control signals.

Crucial to the implementation of the vector control, then, is the acquiring of the instantaneous rotor flux phasor position, θ_r , the field angle can be written as

$$\theta_r = \theta_r + \theta_{sl}$$

where θ_r is the rotor position and θ_{sl} is the slip angle. In terms of speed and time, the field angle can be written as

$$\theta_r = \int (\omega_r + \omega_{sl}) dt = \int \omega_r dt$$

vector control schemes are classified according to how the field angle is acquired. if the field angle is calculated by using terminal voltage and currents or Hall sensors or flux sensing windings, then it is known as direct vector control. The method of direct vector control is made use of in our idea.

Vector control scheme can be summarized as follows.

1. Obtain the field angle.
2. Calculate the flux producing component of the current, i_r , for a required rotor flux linkage λ_r . By controlling only this field current, the rotor flux linkages are controlled. It is very similar to separately-excited dc machine, In that the field current controls the field flux; the armature current has no impact on it.
3. Synthesize these currents by using an inverter; when they are supplied to the stator of the induction generator, the corresponding rotor flux linkages are produced.

RESULTS

1.FLUX CONTROLLED CURRENT TO TERMINAL VOLTAGE

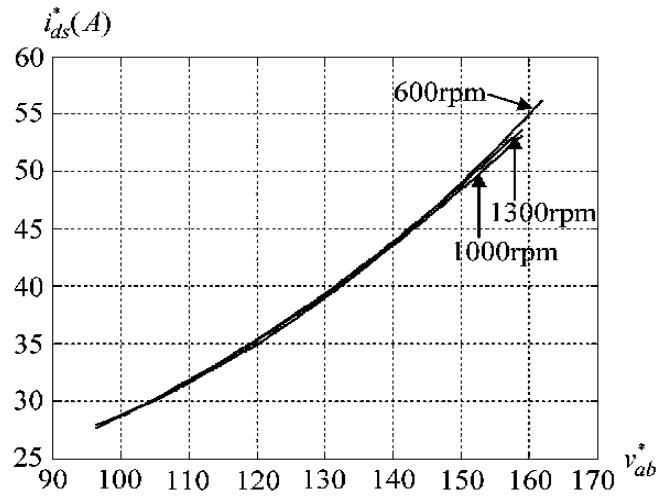

Flux linkage at different rotor speeds of the induction generator

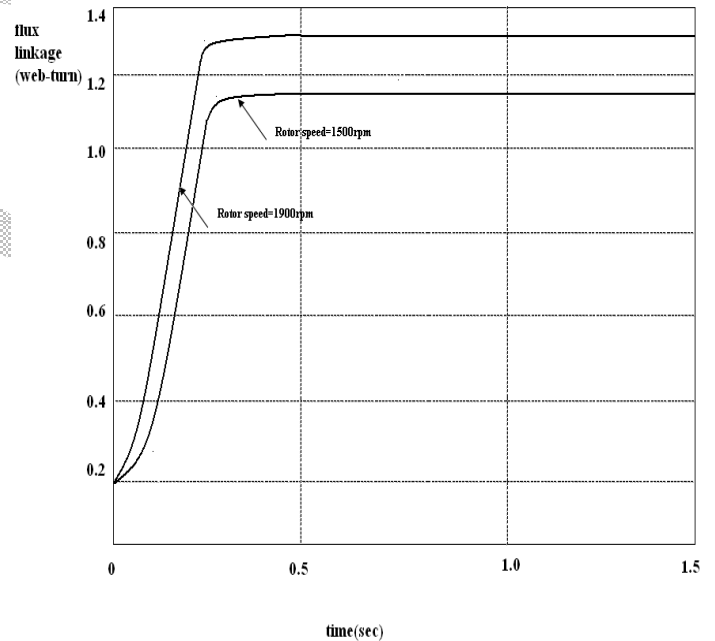

DC voltage at 1500rpm

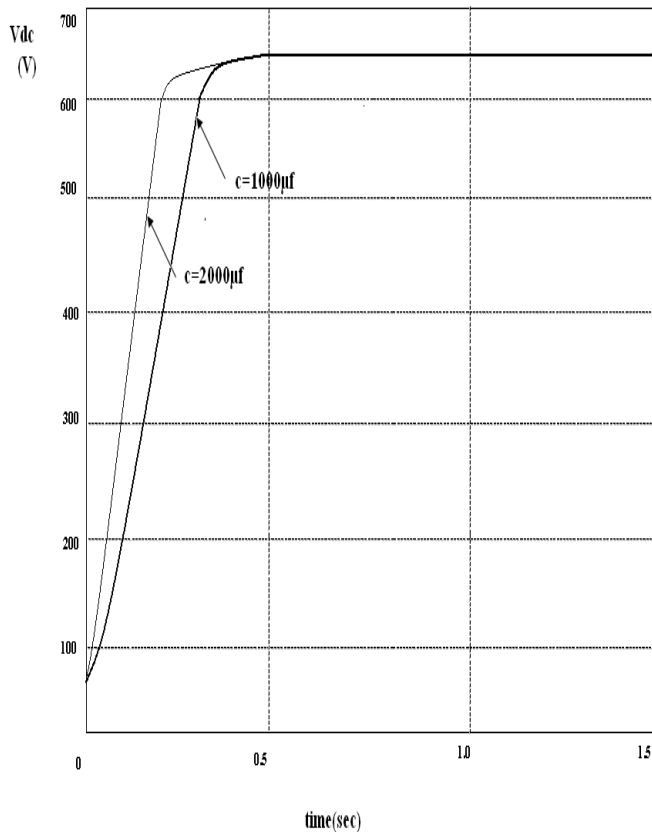

Conclusion:

The voltage control of an induction generator with vector control scheme is presented with help of field control. The total flux linkage is aligned to the d-axis and q-axis current. The equations are developed corresponding to the synchronous reference model of induction machine. The requirement of phase, frequency, and magnitude control of the currents and hence of the flux phasor is made possible by inverter control. The control is achieved in field coordinates. The d-axis current is controlled so that the output voltage can be controlled. The proposed scheme requires on-line computation circuits and rotor speed sensor for its operation. The proposed controller operates the induction generator in constant voltage.

REFERENCES

1) E. Muljadi and t. a. Lipo, "Series compensated pwm inverter with battery supply applied to an isolated induction generator," *IEEE Trans. Ind. Appl.*, vol. 30, no. 4, pp. 1073-1082, Jul./Aug.

1994.

2) E. G. Marra and j. a. Pomilio, "Self-excited induction generator controlled by a vs-pwm bidirectional converter for rural applications," *IEEE Trans. Ind. Appl.*, vol. 35, no. 4, pp. 877-883, Jul./Aug. 1999.

3) E. G. Marra and J. A. Pomillio, "Induction-generator-based system providing regulated voltage with constant frequency," *IEEE Trans. Ind. Electron.*, vol. 47, no. 4, pp. 908-914, Aug. 2000.

4) O. Ojo and i. e. Davidson, "pwm-vsi inverter-assisted stand-alone dual stator winding induction generator," *IEEE Trans. Ind. Appl.*, vol. 36, no. 6, pp. 1604-1611, Nov./Dec. 2000.

5) M. Yamamoto and o. Motoyoshi, "Active and reactive power control for doubly-fed wound rotor induction generator," *IEEE Trans. Power Electron.*, vol. 6, no. 4, pp. 624-629, Jul. 1991.

6) R. Pena, j. c. Clare, and g. m. Asher, "Doubly fed induction generator using back-to-back pwm converters and its application to variable speed wind-energy generation," *Proc. Inst. Elect. Eng.*, vol. 143, no. 3, pp. 231-241, 1996.

7) S. Wekhande and v. Agarwal, "Simple control for a wind-driven induction generator," *IEEE Ind. Appl. Mag.*, vol. 7, no. 2, pp. 44-53, Mar./Apr. 2001.

8) Bhim Singh "Induction generators-A prospective", *Int.J. on Electrical machines and power systems*, vol. 23, 1995, pp. 163-77