



## PREPARATION A PROCESS CYCLE FOR TESLA TURBINE

**Vishnu Narayanan**<sup>1</sup> Department of Mechanical Engineering, Chennai Institute of Technology, Chennai, Tamil Nadu, India,

**Keerthi**<sup>2</sup> Department of Mechanical Engineering, Chennai Institute of Technology, Chennai, Tamil Nadu, India

### **Abstract**

*To make use of the natural effect to create a high efficiency process cycle for the tesla turbine , this turbine is not like a conventional turbine which in turn works with a different principle called “boundary layer effect”, the whole system will be insulated in except certain parts so dissipative effects are reduced. We create high efficient process cycle we just eliminated the condenser as a separate unit and added it with the reservoir and it will be assisted by a heat sensor. In this cycle is a combination steam and water is mixed in certain ratio and in temperature that it can be recollected as same water and steam after some work done in turbine with reduction in temperature. Whereas other than any turbine this turbine will work with mixed fluid so the wet steam is not at all a problem for the working of the turbine, it works with a centripetal flow of fluid through it. In this cycle heat input will maximum at starting after some point it reduces to some folds and remains constant.*

**Keywords:** Centripetal, nozzle, Superheated, Steam, Water.

### **I. Introduction:**

Tesla turbine is a bladeless centripetal flow turbine patented by Nikola Tesla in 1913. It is referred to as a bladeless turbine because it uses the boundary layer effect and not a fluid impinging upon the blades as in a conventional turbine. Available research results and documented functional tests about this more than 100 years old invention, although it is said to have efficiencies of more than 95 %. By using the one fluid medium, Warren Rice, a professor of engineering at Arizona State University, created a version of the Tesla turbine that operated at 41% efficiency. To improve the efficiency, we used the mixed fluid (steam + water).

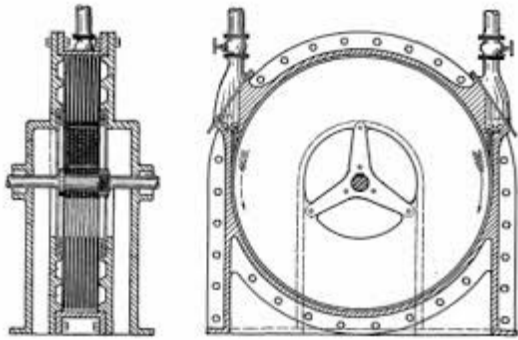

Fig 1. Telsa Turbine

## II. Fluid Path:

Fluid is inserted under pressure through the right valve tangentially to the discs. By the viscosity of the medium and the adhesion between the medium and the disc surface, a tangential force is exerted on the discs which sets the rotor in a clockwise rotation. The thin layer of fluid that interacts with the disk surface in this way is called the boundary layer, and the interaction of the fluid with the solid surface is called the boundary layer effect. As a result, the propelling fluid follows a rapidly accelerated spiral path along the disk faces until it reaches a suitable exit. Because the fluid moves in natural paths of least resistance, free from the constraints and disruptive forces caused by disc, it experiences gradual changes in

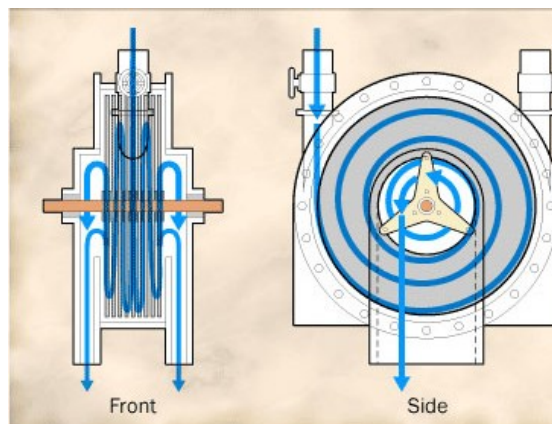
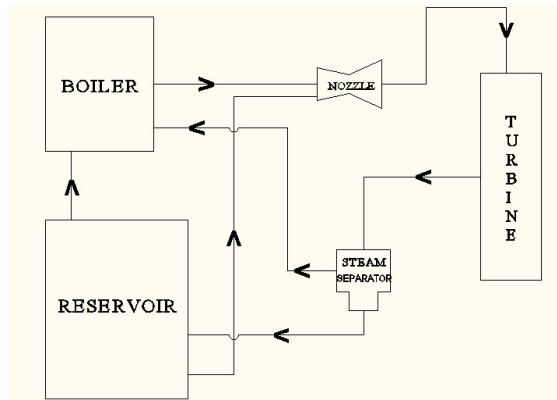

Fig 2. Fluid Path velocity and direction.

## III. Process Circuit:

To create high efficient process cycle we just eliminated the condenser as a separate unit and added it with the reservoir and it will be assisted by a heat sensor.



This combination steam and water is mixed in certain ratio and in temperature that it can be recollected as same water and steam after some work done in turbine with reduction in temperature. Whereas other than any turbine this turbine will work with mixed fluid so the wet steam is not at all a problem for the working of the turbine, it works with a centripetal flow of fluid through it.

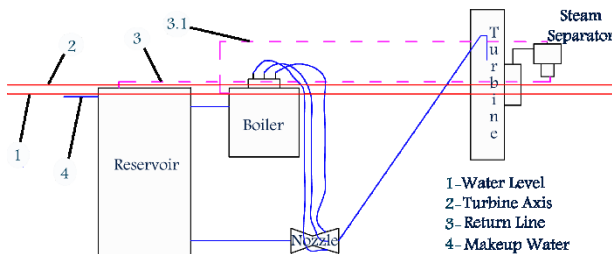

**IV. Reservoir:**

The reservoir is fully stored with water to certain level so that it will give the output with required mass flow rate. The reservoir is designed in a way such that it gives constant outlet of water at required rate. A cooling tower effect is used to made the water particles to reduce its heat by induced draft and the cooling water supply is done with the help of the sensors. Now the water comes in to the required temperature which is optimized for mixing process.

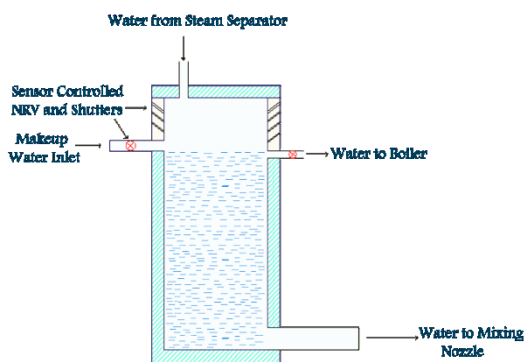

**V. Boiler:**

At the start of the cycle the water enters the boiler and leaves as steam, after the first cycle no water will be allowed to enter the boiler The boiler heating system will be assisted by control system with sensor After that unless otherwise the system requires more input the sensors

allow the water to the boiler to generate more steam The work of the boiler is to increase the temperature of the steam so the flow velocity of the steam will be increased Since the velocity of the steam alone will be used to multiply the flow energy by drawing in the water and mixing with it

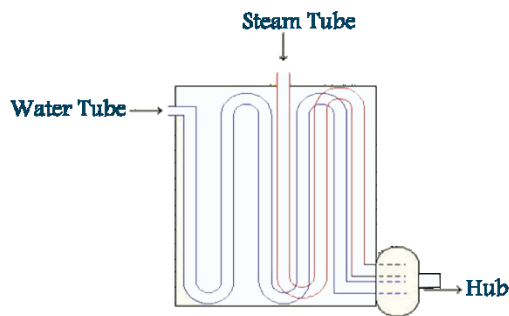

### VI. Mixing Nozzle:

The mixing nozzle is the essential part of the cycle here the water and steam mixes into one, say for example the steam is about 2500C and water is about 500C both mixes at the ratio of 1:3, when fluids mixes the final result will be of same matter i.e., there will be water and steam of same ratio with reduction in temperature.

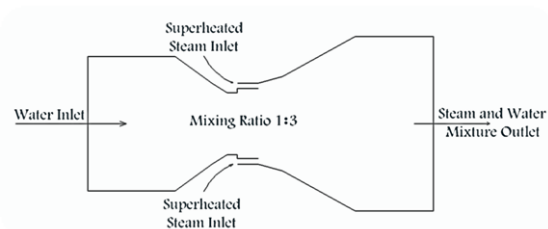

Fig

By the resultant of this effect the pressure of the steam is reduced and by the way flow velocity of the water is increased by vacuum created by the flow of the steam. Due to the increase in the flow and the turbine specifically works on velocity of fluid not because of the pressure and temperature, this produces work done which is required.

What is the final temperature after mixing?

With this calculator you can determine the final temperature of a solution after mixing two or more solutions together. This is for water in liquid, gaseous (steam), or solid (ice) form.

Mass units:   
Temperature scale:

Result of mixing:

of  in temperature   
 of  in temperature

[Add another field](#) | [Clear all fields](#)

RESULT:  
3000g of water and 1000g of steam in temperature  
100 C deg

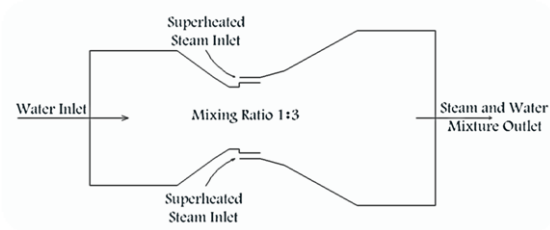

## **VII. Steam Separator:**

Now the velocity of the steam is reduced but its pressure and temperature are not greatly reduced. Since the turbine is insulated. The water and steam is in mixed state now the steam separator is installed to split water and steam. It supplies the water to the reservoir and steam to the boiler. The steam supplied to the boiler is less in temperature when compared to the outlet of the boiler.

## **VIII. Conclusion:**

This Project helps us to increase the efficiency of Telsa turbine as Telsa claimed in his patent and get the maximum efficiency of the turbine. Ultimate goal was to replace the piston combustion engine with a much more efficient, more reliable engine based on his technology. The most efficient piston combustion engines did not get above 27 to 28 percent efficiency in their conversion of fuel to work. Even at efficiency rates of 40 percent, Tesla saw his turbine as an improvement.

## **Reference:**

- [1] [www.grc.nasa.gov/WWW/k12/airplane/boundlay](http://www.grc.nasa.gov/WWW/k12/airplane/boundlay)
- [2] [en.wikipedia.org/wiki/Tesla\\_turbine](http://en.wikipedia.org/wiki/Tesla_turbine)
- [3] [auto.howstuffworks.com/tesla-turbine](http://auto.howstuffworks.com/tesla-turbine)