

Joanna Woźniak¹
Andrzej Paszkiewicz
Grzegorz Budzik
Łukasz Przeszlowski
Mateusz Kielbicki
Dominik Zimon

DEVELOPMENT OF ADDITIVE TECHNOLOGIES IN THE LIGHT OF THE INDUSTRY 4.0 AND INDUSTRY 5.0 CONCEPTION IN ACCORDANCE WITH THE IOE IDEA

Article info:
Received 21.05.2023.
Accepted 15.12.2023.

UDC – 662.2.03
DOI – 10.24874/IJQR18.02-21



Abstract: *The main objective of the publication is to analyze the development of additive manufacturing systems based on the concepts of Industry 4.0 and Industry 5.0, with particular emphasis on the Internet of Everything ideology. In connection with that, the authors have resolved to review the existing devices, and also IT tools, which are applied in manufacturing processes based upon additive technologies. In order to facilitate the analysis in question, three variants were developed; the first, presenting 3D printing as a self-contained manufacturing work station not involving other technologies within the Industry 4.0 conception, the second, indirectly involving 3D printing in the Industry 4.0 conception, and also the third, in which 3D printing constitutes a major and indispensable element of this conception. The contemporary literature of the subject includes dissertations claiming that the fifth industrial revolution may be coming. Taking that into account, this dissertation attempts as well to discuss the evolution of 3D printing in the context of the 5.0 Industry conception, based upon the Internet of Everything, and also Virtual Reality. This part of the article is a forecast of the things to come.*

Keywords: *Additive Manufacturing, Industry 4.0, Industry 5.0, Internet of Everything, Supply Chain Management.*

1. Introduction

In the times of the Fourth Industrial Revolution, 3D printing plays a major role in manufacturing items coming in complex and highly tailored geometries. Prototypes and finished products are successfully manufactured (with the application of it) for the automotive (Khan et al., 2024; Shahrubudin & Lee, 2019; Makhkamova, 2024), aircraft (Alami et al., 2023; Careri et al., 2023), medical (Weilu & Yinghui, 2024; Salmi, 2021), electromechanical (Zhang et

al., 2020; Naseer et al., 2021), construction (Baigarina et al., 2023; Bos et al., 2016) and food (Chen et al., 2024; Koirala et al., 2023) industry. Nowadays, the manufacturers of 3D printers, and also the providers of IT services, are developing solutions rendering it possible to commission, and also to monitor, manufacturing processes remotely, which significantly contributes to increased manufacturing efficiency (Bajic et al., 2023; Rahman et al., 2022; Paszkiewicz et al., 2020). In addition to that, by means of applying robots (collaborative and mobile),

¹ Corresponding author: Joanna Woźniak
Email: j.wozniak@prz.edu.pl

it is possible to manufacture 3D models without interruption, whilst offering a short manufacturing time and a competitive price (Hernández-Del-Valle et al., 2023; Safeea et al., 2022). Increased manufacturing automation, and also data collecting and flow with the application of the Internet of Things, result in turning the vision of the Smart Factory into reality (Grenčíková et al., 2021; Woźniak et al., 2021, Irpan *et al.*, 2023). Dispersed supply and manufacturing chains have become reality as well, rendering it possible to create new business models, and liaising product designers with end users (Akbar et al., 2022; Milosavljevic et al., 2024). The fruit of that is integrating data, information, and also processes within the Internet of Everything conception.

The contemporary literature of the subject includes dissertations claiming that the fifth industrial revolution may be coming. The contemporary literature of the subject includes dissertations claiming that the fifth industrial revolution may be coming. A debate on this issue has already been commenced by scientists, researchers and politicians presenting various visions (European Commission, 2020 and 2021; Ismail et al., 2024; Doyle-Kent, 2019; Jovičić, *et al.*, 2023). The industrial revolution encompasses technological, economic, and social transformations associated with the rise of large-scale factory industry and modern industrial civilization, leading to changes in work processes and conditions (Herrmann, 2018). Each of the previous revolutions is characterized by specific principles and slogans. Currently, we are unable to determine which technologies will be leading the fifth industrial revolution. However, it can be presumed that it will be another step towards increasing production efficiency and mass customization of products.

Therefore, the main objective of this publication is to analyze the development of additive manufacturing systems based on the concepts of Industry 4.0 and Industry 5.0, with particular emphasis on the idea of the

Internet of Everything.

The study attempts to address the following research questions:

- What is the path to full automation of production lines in the 3D printing industry in light of the concept of Industry 4.0?
- What directions of change for the 3D printing industry may occur in the context of implementing the Industry 5.0 concept based on the Internet of Everything and Virtual Reality?

Taking this into account, the study aims to provide information on the possible implications of modern devices and IT tools characteristic of the Industry 4.0 concept in additive manufacturing processes. The functionality of IT tools was examined using the example of a product, namely a car mirror holder. The research was conducted at the Laboratory of Rapid Prototyping Systems at the Rzeszów University of Technology. The study also addresses the potential arrival of the fifth industrial revolution and its impact on design and manufacturing processes based on additive technologies.

2. Development of additive technologies

2.1. History of additive technologies

The history of additive technologies is eventful indeed. It began in the 1970s, when the first conceptual work on this technology was conducted. Yet, it is commonly accepted that the birthdate of additive technologies is 1984, when Charles Hull described the process of 3D printing; two years later, he patented it under the name of Stereolithography (SLA). It was Charles Hull as well that, in 1986, established 3D Systems, the company which is still in the market today and which manufactures 3D printers. Ch. Hull is also the creator of the STL file format, which is commonly applied

for developing 3D models (Budzik et al., 2022).

The late 1980s marked another breakthrough in the history of additive manufacturing, as it was then that S. Scott Crump patented the technology known as Fused Deposition Modelling (FDM), which involves developing a model layer after layer (Paoletti, 2018). In 1992, Selective Laser Sintering (SLS) was developed. This technique is more precise than FDM, and that owing to placing following (very thin) layers of materials with the application of a scraper, and sintering them with the application of laser (Badiru et al., 2017).

2006 was when progress in the industry of additive technologies was made again. The first desktop printers were then developed by Adrian Bowyer, who proved that the chosen elements of new 3D printers may be made with the use of another such device (the RepRap project) (RepRap, 2006). In 2009, the Makerbot company launched the first ever self-assembled 3D printer.

In 2013, 3D printers entered mass distribution, and, owing to that, became available to natural persons, not only in retail chains, but also from popular online marketplaces (Rayna & Striukova, 2016).

The year 2014 represented a significant advancement in 3D printing, particularly within the aerospace industry when NASA announced that a 3D printer had printed the first ever artefact onboard the ISS (Clinton, & Morgan, 2015). In turn, 2015 saw the first printer able to print glass items. Scientists from MIT managed to develop the first device able to glass extrusion layer after layer, with the application of a method similar to FDM (Krassenstein, 2015).

In 2017, such companies as Apis Cor and WinSun were set up to offer huge concrete 3D printers, rendering it possible to construct house frames much more rapidly and economically in comparison with traditional methods. Other construction and architectural projects connected with 3D printing were completed in 2016-2019, and

they included bridges, residential buildings, and even skyscrapers in Dubai (APIS COR, 2019).

In 2018-2021, 20% of the companies on the list of Top Global 100 vendors drawn up by Gartner applied 3D printing to develop non-standard products. In a few years, shoes will cease to be sown, and will be printed to suit. An instance of that change is the shops of Adidas and Nike, in which customers can now personalise what they purchase (Materialise; Groot, 2018). Another footwear manufacturer, Brooks, went even further, rendering it possible for customers not only to design their own model, but also to adjust to the anatomy of a purchaser's foot. It is indeed an observable trend in manufacturing; however, considering the costs of producing individualized products, as well as the durability of materials for 3D printing and the user comfort of such products, the trend may not be applicable to mass production.

Recent years in the realm of 3D printing have witnessed advancements in materials and processes that can utilize manufacturing with materials of various strength and visual properties during a single additive process. One example is Desktop Metal, which introduced an innovative 3D printer based on carbon fiber technology in 2022, enabling the rapid production of composite parts with exceptional strength and lightweight properties. This achievement has opened up new possibilities for industrial applications, from aerospace to automotive (Desktop Meta, 2022). Similarly, HP 3D PRINT EUROPE updated its Multi Jet Fusion 5200 printer series, introducing new features and enhancements such as faster printing times, increased accuracy, and flexibility in material options (HP 3D, 2022).

Furthermore, recent years have seen developments in the medical field. Thanks to advancements in 3D printing technology, as well as scanning and 3D modeling, personalized medical implants have become more widely used. These individually tailored implants, such as joint prostheses or

bone fragments, provide better quality of life for patients by minimizing the risk of rejection and accelerating the recovery process. The medical industry has also seen new possibilities in the production of surgical tools with complex shapes and functions. Surgeons can now use tools tailored to specific surgical procedures, contributing to the improvement of precision and effectiveness in surgical procedures (Weilu & Yinghui, 2024).

Therefore, the history of additive manufacturing is a history of continuous progress and innovation. It can be said that additive manufacturing has firmly established itself in our reality, catering not only to the industrial segment but also to the commercial one.

2.2. Adaptation of additive technologies in the structure of Industry 4.0

In the era of the Fourth Industrial Revolution, the adoption of modern production management solutions will gradually become the standard (Madzik *et al.*, 2024; Zimon *et al.*, 2020). According to the principles of the Smart Factory concept, manufacturing enterprises should implement modern technologies characteristic of Industry 4.0. These technologies include, among others, the Internet of Things, Big Data, cyber-physical systems, cloud computing, collaborative robots and mobile robots, as well as RFID and GPS systems.

Nowadays, the numerous manufacturers of 3D printers strive to develop fully-automated production lines. One of these companies is 3D Systems, offering the Figure 4 platform, made of the combinations of several 3D printers supported by robotic arms, which transport finished parts to a final processing work station, where there were additionally cured with the use of UV. The company demonstrated as well a quality control module, in which a robotic arm turns a finished part in front of a scanner, which, in turn, adjusts it to a 3D model in order to check precision and conformity. In a

production lot, the material delivery process is automated as well. It is of importance that the platform has been configured in the aspect of all requirements relevant to the factory environment, including the formation of data collection systems within 4.0 Industry. 3D Systems launched as well DMP 8500 Factory, which is the first truly scalable, automated and fully-integrated solution for manufacturing metal parts with the application of additive technologies. This solution consists of several modules, among others: part manufacturing printer modules, Replaceable Print Modules (RPMs) for transporting toner to printers and finished parts from printers, toner management modules for removing dust from parts on working platforms before the unused toner is recycled, and also transport modules, which carry RPM between a printer and toner modules.

Another instance of the application of the Industry 4.0 conception in enterprises in the rapid prototyping industry is constituted by Stratasys. This company launched Continuous Build 3D Demonstrator. Manufacturing process is supervised by the central system in a cloud. Each and every of additive devices working in FDM technology conducts an independent 3D printing process, which requires least intervention of an operator. After obtaining a real item, a 3D printer automatically slides the model into a mounted container and immediately commences another printing process. Therefore, this system renders it possible to ensure continuous manufacturing and reduce the time required for obtaining a finished element. Stratasys, apart from Demonstrator, offers as well solutions which are fully compatible with the conditions of work in the production environment based upon large robotic systems. Robotic Composite 3D Demonstrator is a robotic arm with a 3D printing head. Unlike traditional 3D printers, having no more than three axes, this robot has eight. Material used in manufacturing is a plastic strengthened with the use of carbon fiber. These robust

materials are appropriate in many cases, among others, in the automotive and aircraft industries.

Based on the above solutions, it can be concluded that utilizing modern technologies in production management not only becomes the norm but is crucial for the efficiency, flexibility, and competitiveness of manufacturing enterprises in the era of Industry 4.0. The adaptation of additive manufacturing within the framework of Industry 4.0 promotes further automation of production processes, resulting in increased quality, precision, and safety of production. The utilization of advanced robots, vision systems, and machine learning algorithms allows for the elimination of human errors and improvement in the efficiency and reliability of production processes.

However, implementing the concept of Industry 4.0 in a company requires a comprehensive approach and consideration of both technological and organizational aspects. The key factor for success in this case is understanding the unique needs and capabilities of the enterprise and constructing an appropriate implementation strategy.

3. Identification and clasification of additive technologies in supply chain management for the different variants of a manufacturing structure

In the paper, an attempt was made to identify and classify additive manufacturing technologies in supply chain management for various structural production variants. These variants are presented as follows:

- The first variant, where 3D printing functions as an independent manufacturing station without the involvement of other technologies characteristic of Industry 4.0.
- The second variant, indirectly

incorporating 3D printing into the concept of Industry 4.0, where applications for remote control of 3D printers are utilized.

- The third variant, in which 3D printing constitutes a significant and integral element of this concept.

3.1. Variant 1 - direct

Variant 1 is the one in which 3D printing is conducted at a self-contained manufacturing work station not involving other technologies within the Industry 4.0 conception.

An instance of this variant may be constituted by a direct structure presented in Figure 1 it constitutes the simplest possible structure, and involves solely collaboration between a computer and 3D printer. The activities within the scope of pre-processing, and also post-processing, are all conducted by human labour force.

In this system, a computer is provided with 3D-CAD software, and also another software for printer 3D management. That renders it possible to develop 3D-CAD models, processing data into formats readable for 3D printers, and also starting and monitoring manufacturing process. Previewing an STL file, and also ordering it to be printed, without it being necessary to install additional applications, is possible with the application of a Print 3D tool of Microsoft Corporation (Figure 2).

Minimum requirement for Print 3D is Windows 10 (15063.0, or more modern) or Xbox One. Having a STL file on a hard disk, it is sufficient to click Open, which starts the tool automatically, and the screen displays a model preview. This tool renders it possible to order printing a given model for devices connected to a computer, and contacting it via Wi-Fi. In the case of applying older solutions, it is required to ensure constant communication between a 3D printer and a computer. Data may as well be carried with the use of USB flash drivers.

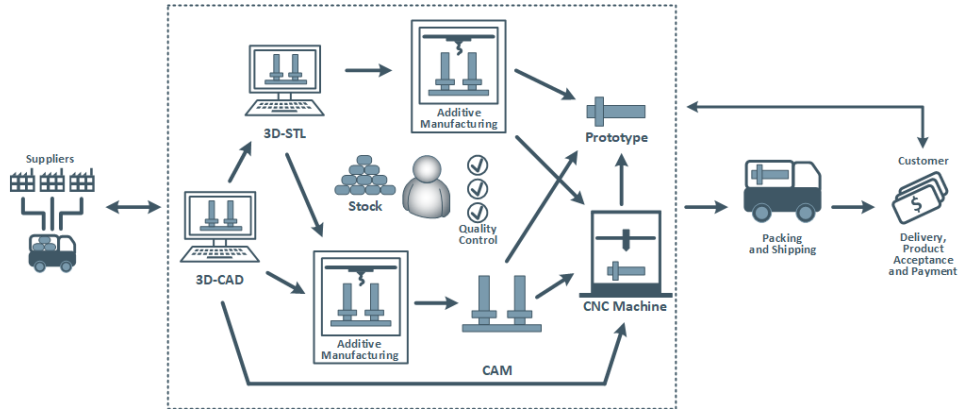

Figure 1. Direct structure

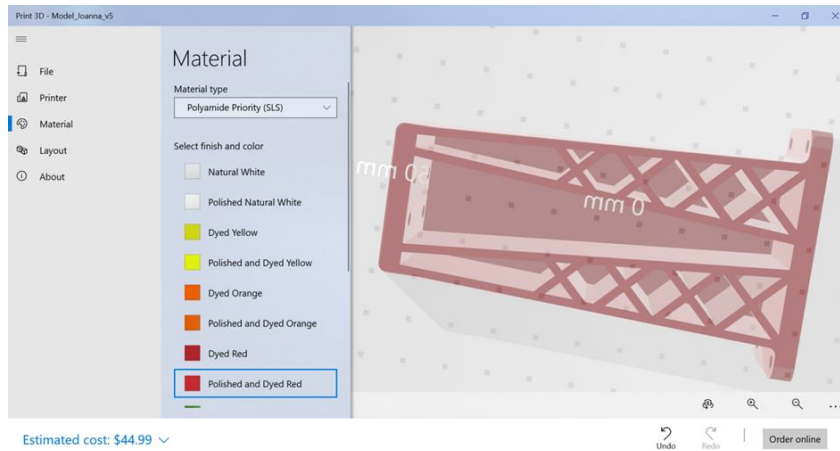

Figure 2. Selected research model presented in the Print 3D program

3.2. Variant 2 - remote

Variant 2, by means of applying a 3D printer remote control application by an operator,

partly involves 3D printing into the Industry 4.0 structure. In Figure 3, an instance of remote structure is presented.

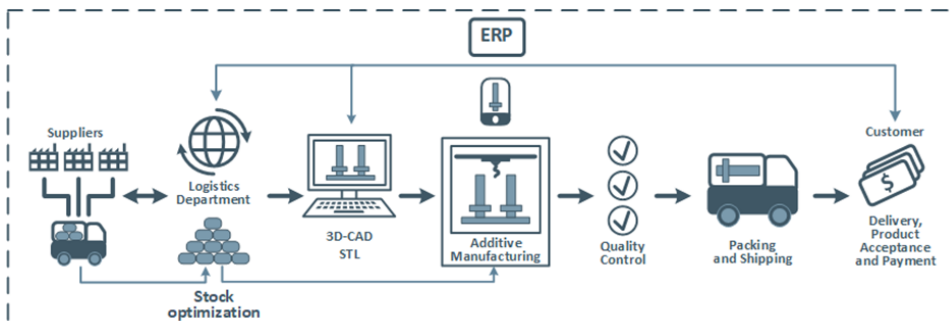

Figure 3. Variant 2 – remote

There are finished tools in the market which render it possible to control and manage 3D printer remotely from anywhere where the Internet can be accessed. An instance is, to mention, but one, a tool known as OctoPrint, which, together with a camera, renders it possible to control and manage printing process with the use of a smartfon and in real time.

In the Rapid Prototyping Systems Laboratory of the Rzeszow University of Technology, Octo-Print was implemented.

The operator of a 3D printer, therefore, can monitor manufacturing process remotely, which reduces the risk of obtaining an incompatible product, and also damaging the machine while the operator is absent in the Laboratory.

The photographs of the manufacturing cell, software interface, and also particular stages of manufacturing process controlled with the application of Octo-Print, are presented in Figure 4.

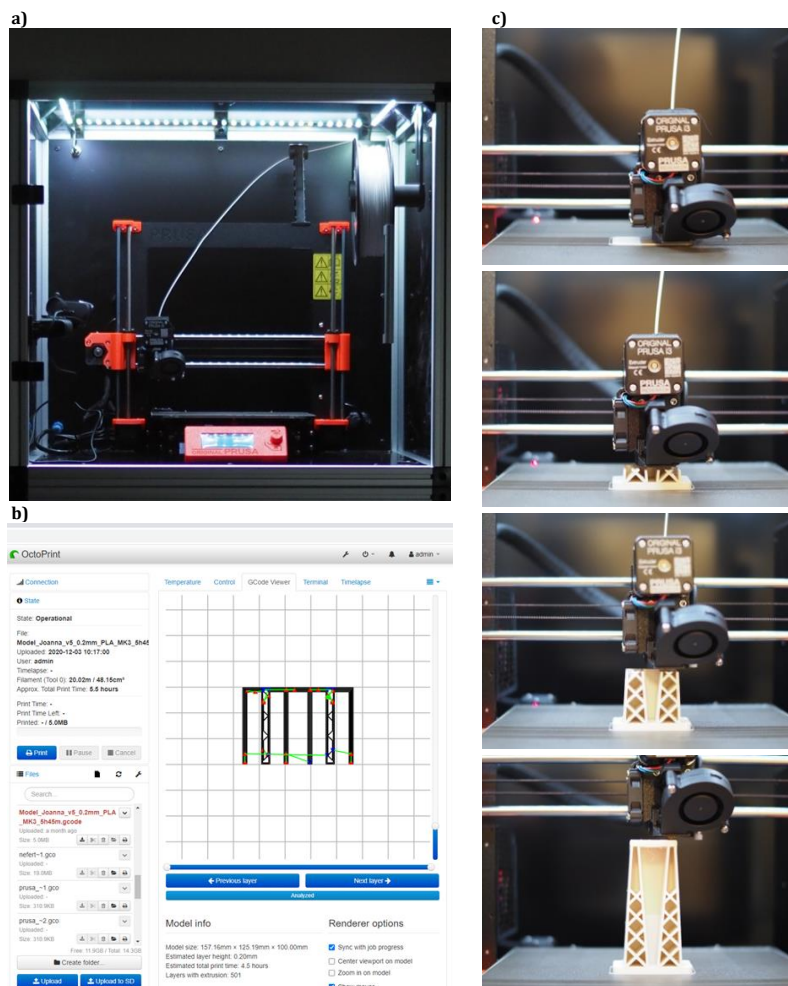

Figure 4. a) Manufacturing cell in the Rapid Prototyping Systems Laboratory of RUT; b) Octo-Print Software interface; c) Controlling the process with the application of Octo-Print

3.3. Variant 3 – within the Industry 4.0 conception

Variant 3 involves 3D printing conducted entirely within the Industry 4.0 conception in a company.

Figure 5 presents the instance of a structure in the network within the Industry 4.0

conception. In the discussed structure, there is a Smart Factory model with implemented technologies typical of this conception, to mention, but those: the Internet Of Things, Big Data, cyber-physical systems, computing cloud, collaborative and mobile robots, and also RFID and GPS systems.

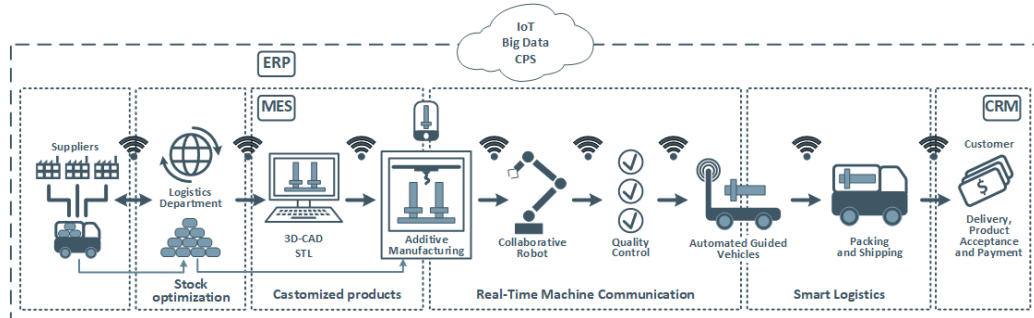

Figure 5. Additive technologies in the light of the Smart Factory conception

In the Rapid Prototyping Systems Laboratory, work on implementing modern technologies typical of the Industry 4.0 conception is under way. Manufacturing process is supervised with the application of Octo-Print. In addition to that, the Rzeszow University of Technology is conducting research together with the B&M OPTIK company, aiming at integrating 3D printers

with UR3 (Universal Robot) collaborative robots, which will render it possible to ensure continuous manufacturing 24h a day without the involvement of human labour force.

Figure 6 presents a collaborative robot with a 3D printer - Prusa i3 MK3S.

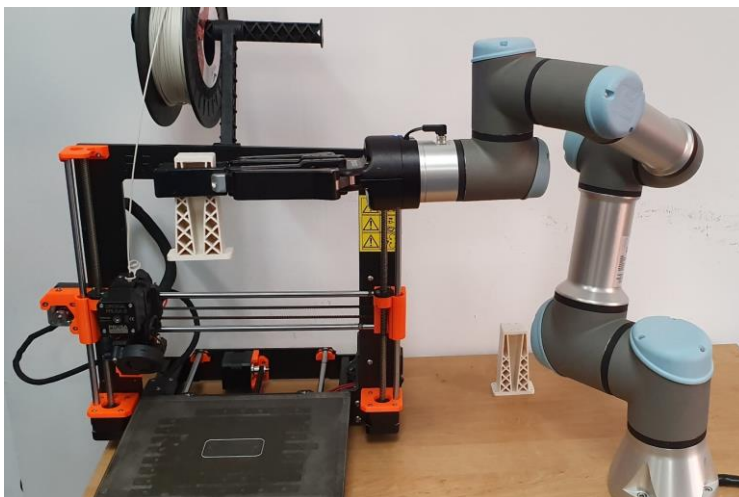

Figure 6. Collaborative robot with printer 3D - Prusa i3 MK3S

Furthermore, in collaboration with Proximo Aero, a feeding-sorting workstation (Figure 7) was developed for components printed

using multiple 3D printers, incorporating a collaborative robot for retrieving and depositing work platforms using a gripper.

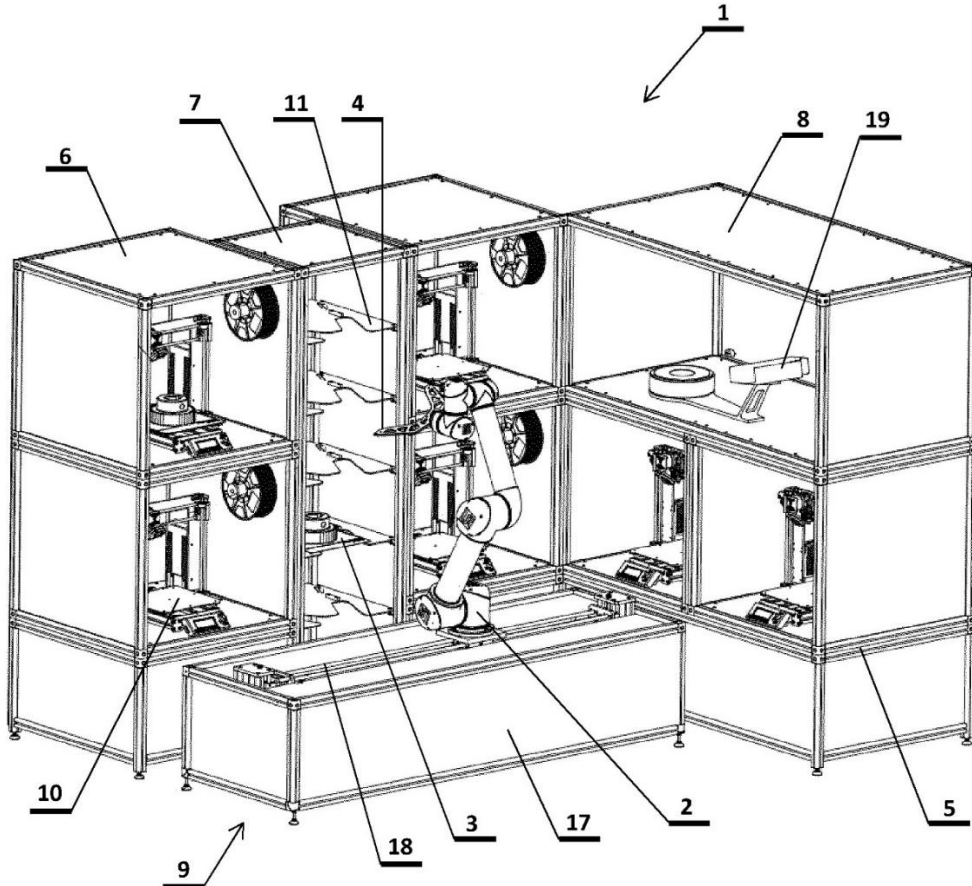

Figure 7. Feeding-sorting workstation, where: 1- feeding-sorting station, 2- collaborative robot, 3- work platform, 4- gripper, 5- frame, 6- printing segment, 7- feeding-sorting segment, 8- measurement segment, 9- drive track assembly, 10- printing device, 11- shelves, 12- cutout, 13- limiter, 14- arm, 15- magnet, 16- positioning pin, 17- base, 18- track, 19- scanning device.

The feeding-sorting workstation is comprised of the following components:

- Manufacturing section consisting of a set of 3D printers, the number of which may depend on the dimensions and reach of the collaborative robot, further equipped with a track assembly to extend its reach.
- Storage section housing empty platforms for 3D printers and equipped with depositing grips for platforms with printed elements.
- Feeding section, featuring the collaborative robot as its main component, network-integrated with the 3D printers. Communication between devices enables automatic operation of the production slot in an unmanned mode.

- Measurement section equipped with a 3D structural light scanner for measuring objects, allowing for rapid verification of the shape of the product positioned on the work platform. Measurements are referenced to a digital model, which serves as the basis for the 3D printing process.

The advantage of the feeding-sorting workstation for elements printed in a multi-3D printer setup lies in its simple, modular construction, enabling expansion of the workstation to an unlimited extent. Additionally, it allows for the use of a single collaborative robot, which can handle segments of the feeding-printing workstation without limitations thanks to the use of a track assembly assembly.

4. Additive technologies in the times of Industry 5.0

The above-presented Variant 3 additive technologies based upon the 4.0 Industry conception has not been implemented in full yet. In numerous factories, design and manufacturing processes have not been informatised at an adequate level appropriate for the 4.0 Industry. It ought to be presumed that many of them will not manage to do this before the arrival of the next industrial revolution, namely 5.0 (Sari et al., 2020).

Nowadays, we are witnessing not only the significant shortening of product lifetime, but, as well, or, perhaps, first and foremost, the periods of time between fundamental changes in premises, rules and principles, and also processes constituting the cornerstones of the functioning of particular areas of social and economic life. Such changes, referred to as revolutions, are observed in industry, education, society and not only there. For that very reason, the pace and scope of processes, frequently triggered locally, and reaching a worldwide scale in a short time, prevents some entities (prospective participants) from being able to

catch up and follow, which usually results from the lack of appropriate resources: knowledge, capital, personnel, but, as well, from pressure and the internal situation of an entity, and also external factors (ASTOR, 2017). In the past, time at disposal for adjusting to changing economic conditions was usually longer; nowadays, it is much shorter and it ought to be expected that it will be becoming even shorter in the future.

Concentrating upon the 5.0 Industry conception, one ought to ask what the features of this revolution actually are, and what challenges and opportunities are a part and parcel of it. First and foremost, it ought to be said this revolution has been defined as integrating and close collaboration between humans and machines (Doyle-Kent & Kopacek, 2019; Nahavandi, 2019), which may mean return of human labour force to production lines, unlike in the Industry 4.0 conception, which aimed at the maximum automatisisation of the manufacturing processes. This development is the result of numerous experiences within the scope of substantial product personalisation, which requires that humans support robots and manufacturing automatics systems. One could claim that such systems already exist, and, in a way, it would be true as, before we have really become accustomed to the idea of Industry 4.0, and before it could become common, another change is taking place - and that latter one leads us to Industry 5.0.

However, a recent discussion has begun on a new concept of industry. Interest in this aspect is shown by scientists, companies, and political institutions (e.g., reports commissioned by the European Commission) (European Commission, 2020 and 2021; Fraga-Lamas et al., 2021). These studies indicate that the new industry concept, in addition to being human-centric, should also consider sustainability and resilience. Regarding sustainability, emphasis is placed on ecological aspects, energy efficiency, and meeting human needs. On the other hand, concerning resilience, opinions suggest considerations of

globalization aspects and its conditions, crises such as the COVID-19 pandemic, and the dynamics of geopolitical changes. The assumptions of this new revolution built on the indicated aspects are not entirely appropriate. We believe that Industry 5.0 must be based on the following foundations:

- Internet of Everything (IoE);
- Human-machine integration;
- Complex Systems;
- Enhanced data processing systems (AI);
- Virtual, Augmented, Mixed Reality Systems.

Of course, the concept of Industry 5.0, its principles, development phases, possibilities, and limitations can be the subject of a separate publication. Especially in terms of focusing on technologies such as bio-inspired technologies and smart materials, Digital twins, etc., Industry 5.0 has

enormous potential. However, considering the main topic of this paper, which is the development of additive manufacturing systems, its new model is presented precisely in the context of the next industrial revolution. One of the stages of development within Industry 4.0 is remote design and manufacturing of components based on distributed resources. However, they still remain separate properties and can be shared in a certain way, while still being under the control and supervision of the parent company managing access to production resources. The completely new approach presented by the authors is based on the assumption that there are entirely virtual design and manufacturing lines, with individual elements belonging to different owners, and supervision of their manufacturing processes occurs virtually (Figure 8).

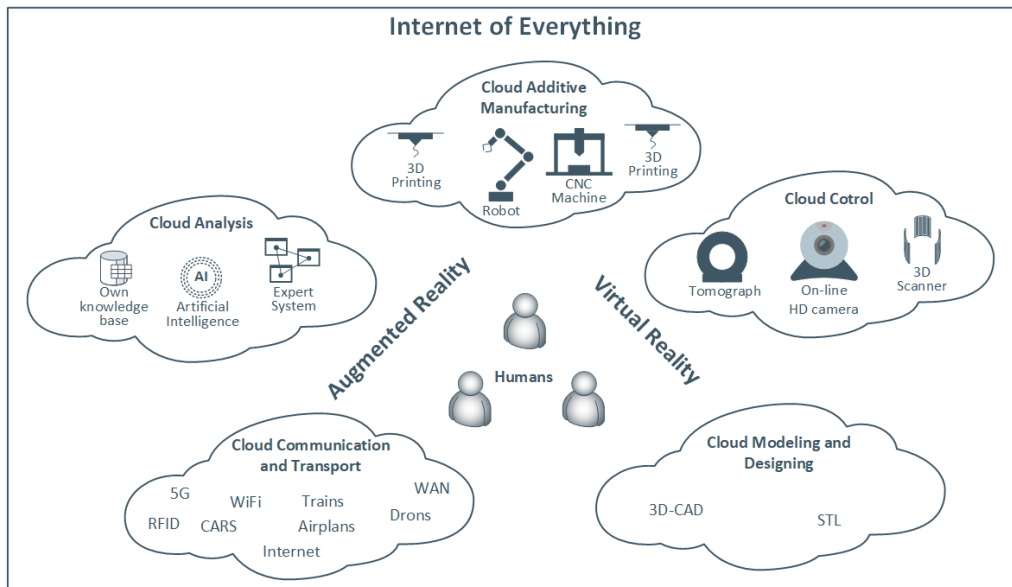

Figure 8. Additive technologies in the light of the 5.0 Industry conception

As it is presented in Figure 11, the effect of another industrial revolution within the scope of additive technologies will be a complete virtualisation of the entire process. Design and manufacturing process line will

cease to exist in the context of particular resources being the property of particular entities. Therefore, this conception is based upon dispersing and transparency of all and any resources. From the point of view of an

end user, it does not matter where particular manufacturing, controlling or analysing etc. elements are. For instance, extensive AI systems will be supporting design process, increase the effectiveness and reliability of manufacturing, and also controlling and measurement processes. However, in terms of accessibility on the World Wide Web, their location will not matter for a customer. Ultimately, even the functioning of such systems will be transparent, will become natural and obvious, without humans being aware of their current impact on manufacturing process. Owing to that, truly virtual production lines, and, in the further course, factories, will be created. A customer/user will be able to operate and control particular stages of the process remotely, and, in numerous cases, with the use of virtual or extended reality. These mechanisms will render it possible as well to integrate a human with machine or robot in a remote location, which would not be possible without the Internet of Everything (IoE) not first becoming common.

The proper integration of resources using the latest technologies will lead to more efficient utilization, consequently reducing energy consumption, positively impacting the environment, and considering the creative input and position of humans in the design and manufacturing process.

5. Conclusion

Additive manufacturing technologies provide the capability to produce arbitrary geometries, thus playing a significant role in industrial applications where conventional production methods are either technically or economically infeasible. Enterprises serious about advancing to the level of Industry 4.0 should therefore consider 3D printing technologies as an alternative or complement to traditional production.

An increasing number of companies offering 3D printing services are moving away from traditional manufacturing, where

all activities related to the manufacturing process are entirely performed by humans. Due to COVID-19, one of the global trends in production and resource management has become the adoption of IT systems enabling the online ordering, operation, and monitoring of production processes. Ready-made IT tools are available on the market that allow for remote control and operation of 3D printers from any location with internet access. Additionally, the utilization of collaborative robots and mobile robots is crucial, as they contribute to the automation of production, thereby reducing the need for human involvement in manual tasks. According to the authors, the improvements presented in the article offer companies the opportunity for development and uninterrupted operation, ultimately leading to increased quality and productivity.

Considering the pace of changes resulting from the onset of the Fourth Industrial Revolution, it should be acknowledged that the advent of Industry 5.0 is only a matter of time. This fact may be unsettling for business owners and managers, as many of them are still at the initial stages of implementing technologies characteristic of the concept of Industry 4.0.

In the context of implementing the Industry 5.0 concept in the 3D printing industry, several directions of change can be foreseen, including digital supply chain integration. Furthermore, the development of artificial intelligence used for analyzing process data will enable the development of machine learning algorithms that can help improve print parameters, predict defects, and optimize efficiency. The introduction of Industry 5.0 may thus lead to the improvement of production processes using intelligent systems that monitor, optimize, and adjust production in real-time. The Fifth Industrial Revolution also envisages close collaboration between workers and technological systems. People will no longer be mere users of technology but active participants in production processes. Therefore, company management should be

aware of the need to adapt their organization to the inevitable future in which humans and machines will collaborate, leveraging the potential of the Internet of Everything, as well as Virtual and Augmented Reality.

References:

- 3D Systems, from <https://www.3dsystems.com/3d-printers/figure-4>, and <https://www.3dsystems.com/3d-printers/dmp-factory-500>, accessed March 12, 2024.
- Akbar, U. A., Mekid, S., Alsawafy, O., & Hanbali, A. A. (2022). Design and Development of Best Class Discrete Production Model for Distributed Manufacturing under Industry 4.0. *Arabian Journal for Science and Engineering*, 47(12), 16485–16504. doi: 10.1007/s13369-022-07061
- Alami, A. H., Ghani Olabi, A., Alashkar, A., Alasad, S., Aljaghoub, H., Rezk, H., & Abdelkareem, M.A. (2023). Additive manufacturing in the aerospace and automotive industries: Recent trends and role in achieving sustainable development goals. *Ain Shams Engineering Journal*, 14(11), 102516. doi: 10.1016/j.asej.2023.102516
- APIS COR. (2019). The world's biggest 3D printed building, Retrieved from <https://www.apis-cor.com/dubai-project>, accessed March 5, 2024.
- ASTOR WHITEPAPER (2017). Engineer 4.0 (Not) ready for changes? Retrieved from https://www.astor.com.pl/downloads/pliki/ASTOR_Whitepaper_Engineer40_Not_ready_for_changes_2019.pdf, accessed March 5, 2024.
- Badiru, A. B., Valencia, V. V., & Liu, D. (2017). *Additive Manufacturing Handbook book. Product Development for the Defense Industry*. CRC Press.
- Baigarina, A., Shehab, E., & Ali, M.H. (2023). Construction 3D printing: a critical review and future research directions. *Progress in Additive Manufacturing*, 8(6), 1393–1421. doi: 10.1007/s40964-023-00409-8
- Bajic, B., Suzic, N., Moraca, S., Stefanović, M., Jovicic, M., & Rikalovic, A. (2023). Edge computing data optimization for smart quality management: industry 5.0 perspective. *Sustainability*, 15(7), 6032.
- Bos F., Wolfs R., Ahmed Z., & Salet T. (2016). Additive manufacturing of concrete in construction: potentials and challenges of 3D concrete printing. *Virtual and Physical Prototyping*, 11(3), 209-225, doi: 10.1080/17452759.2016.1209867
- Budzik, G., Woźniak, J., & Przeszlowski, Ł. (2022). *Druk 3D jako element przemysłu przyszłości. Analiza rynku i tendencje rozwoju*. Oficyna Wydawnicza Politechniki Rzeszowskiej. Rzeszów. ISBN 978-83-7934-610-3
- Careri, F., Khan, R. H. U., Todd, C., & Attallah, M. M. (2023). Additive manufacturing of heat exchangers in aerospace applications: a review. *Applied Thermal Engineering*, 235, 121387. doi: 10.1016/j.applthermaleng.2023.121387
- Chen, Y., McClements, D.J., Peng, X., Chen, L., Xu, Z., Meng, M., Zhou, X., Zhao, J. & Jin, Z. (2024). Starch as edible ink in 3D printing for food applications: a review. *Critical Reviews in Food Science and Nutrition*, 64(2), 456–471. doi: 10.1080/10408398.2022.2106546
- Clinton, R.G.Jr. & Morgan, K. (2015). Additive Manufacturing at NASA Marshall Space Flight Center: In-space and For-space Initiatives, Retrieved from <https://ntrs.nasa.gov/api/citations/20160000460/downloads/20160000460.pdf>, accessed March 5, 2024.

- Desktop Meta (2022). Retrieved from <https://www.desktopmetal.com/>, accessed March 12, 2024.
- Directorate-General for Research and Innovation (European Commission 2020), J. Müller, Enabling Technologies for Industry 5.0. Results of a workshop with Europe's technology leaders, from <https://op.europa.eu/en/publication-detail/-/publication/8e5de100-2a1c-11eb-9d7e-01aa75ed71a1/language-en>, accessed February 25, 2024.
- Doyle-Kent M., & Kopacek P. (2019). Industry 5.0: Is the Manufacturing Industry on the Cusp of a New Revolution?, In: Durakbasa N. M., Gençyılmaz M. G. (red.), *Proceedings of the International Symposium for Production Research 2019*, Springer, London, UK, 432-441, doi: 10.1007/978-3-030-31343-2_38
- European Commission. Industry 5.0 - Towards a sustainable, humancentric and resilient European industry. Accessed: July 17, 2021. from https://ec.europa.eu/info/publications/industry-50_es, accessed February 25, 2024.
- Fraga-Lamas, P., Varela-Barbeito, J., & Fernández-Caramés, T. M. (2021). Next Generation Auto-Identification and Traceability Technologies for Industry 5.0: A Methodology and Practical Use Case for the Shipbuilding Industry. *IEEE Access*, 9, doi: 10.1109/ACCESS.2021.3119775.
- Grenčíková, A., Kordoš, M., & Berkovič, V. (2021). Expected changes in slovak industry environment in terms of Industry 4.0. *International Journal for Quality Research*. 15(1), 225–240. doi: 10.24874/IJQR15.01-13
- Groot, A. (2018). The Future at Nike: 3D printing customized shoes at home. Retrieved from <https://digital.hbs.edu/platform-rctom/submission/the-future-at-nike-3d-printing-customized-shoes-at-home/>, accessed March 7, 2024.
- Hernández-Del-Valle, M., Schenk, C., Echevarría-Pastrana, L., Ozdemir, B., Wang, D.-Y., & Haranczyk, M. (2023). Robotically automated 3D printing and testing of thermoplastic material specimens. *Digital Discovery*, 2(6), 1969–1979. doi: 10.1039/d3dd00141e
- Herrmann, F. (2018). The Smart Factory and Its Risks, *Systems*, 6(4), 38, doi: 10.3390/systems6040038
- HP 3D PRINT EUROPE. (2022). Retrieved from <https://hp3dprint.eu/>, accessed March 12, 2024.
- Irpan, M., Summantri, A., Kurniawati, M. F., Sukmana, R. A., & Shaddiq, S. (2023). Digital communication in agricultural extension in the era of the industrial revolution 4.0. *Journal of Engineering, Management and Information Technology*, 1(4), 177-190.
- Ismail, M. M., Ahmed, Z., Abdel-Gawad, A. F., & Mohamed, M. (2024). Toward Supply Chain 5.0: An Integrated Multi-Criteria Decision-Making Models for Sustainable and Resilience Enterprise. *Decision Making: Applications in Management and Engineering*, 7(1), 160–186. doi: 10.31181/dmame712024955
- Jovičić, A., Savković, M., Stefanovic, M., Macuzic, I., & Nikolić, N. (2023). The impact of horizontal and vertical system integration on quality 4.0. *Journal of Innovations in Business and Industry*, 1(4), 191-200.
- Khan, A., Singh, A. K., & Dugala, N.S. (2024). Leverage of Metal 3D Printing Technology in the Automotive Industry. *Lecture Notes in Mechanical Engineering. International Conference on Production and Industrial Engineering, CPIE 2023*, 159–172. doi:10.1007/978-981-99-6094-1_17

- Koirala, S., Prakash, S., Karim, A., & Bhandari, B. (2023). Shape morphing of foods: Mechanism, strategies, and applications. *Trends in Food Science and Technology*, 139, 104135. doi: 10.1016/j.tifs.2023.104135
- Krassenstein, B. (2015). G3DP Project: Mediated Matter & MIT Glass Lab Develop Advanced Glass 3D Printer, from <https://3dprint.com/90748/g3dp-glass-3d-print/>, accessed March 5, 2024.
- Madzik, P., Falat, L., Jum'a, L., Vrábliková, M., & Zimon, D. (2024). Human-centricity in Industry 5.0—revealing of hidden research topics by unsupervised topic modeling using Latent Dirichlet Allocation. *European Journal of Innovation Management*. Vol. ahead-of-print No. ahead-of-print. <https://doi.org/10.1108/EJIM-09-2023-0753>
- Makhkamova, A. (2024). Determination of the Friction Coefficient by Using 2D and 3D Parameters of the Tools. *Journal of Materials and Engineering*, 2(2), 119-124.
- Materialise. Adidas Futurecraft: The Ultimate 3D-Printed Personalized Shoe, from <https://www.materialise.com/en/cases/adidas-futurecraft-ultimate-3d-printed-personalized-shoe>, accessed March 7, 2024.
- Milosavljevic, M., Mousavi, A., Moraca, S., Fajsi, A. & Rostohar, D. (2024). Revealing the Supply Chain 4.0 Potential within the European Automotive Industry. *Sustainability*, 16(4), 1421. doi: 10.3390/su16041421
- Nahavandi, S. (2019). Industry 5.0- A Human-Centric Solution. *Sustainability*, 11(16), 4371, doi: 10.3390/su11164371
- Naseer, M.U., Kallaste, A., Asad, B., Vaimann, T. & Rassõlkin, A. (2021). A review on additive manufacturing possibilities for electrical machines. *Energies*, 14(7), 1940. doi: 10.3390/en14071940
- Octoprint, Retrieved from www.octoprint.org, accessed March 12, 2024.
- Paoletti, I. & Ceccon L. (2018). The Evolution of 3D Printing in AEC: From Experimental to Consolidated Techniques, In: Cvetković D. (ed.), *3D Printing*, 39-69, doi: 10.5772/INTECHOPEN.79668
- Paszkiwicz A., Bolanowski M., Budzik G., Przeszłowski Ł. & Oleksy M. (2020). Process of Creating an Integrated Design and Manufacturing Environment as Part of the Structure of Industry 4.0. *Processes*, 8(9), 1019, doi: 10.3390/pr8091019
- Rahman, M. A., Shakur, M. S., Ahamed, M. S., Hasan, S., Rashid, A. A., Islam, M.A., Haque, M. S. S., & Ahmed, A. (2022). A Cloud-Based Cyber-Physical System with Industry 4.0: Remote and Digitized Additive Manufacturing. *Automation*. 3(3), 400–425. doi: 10.3390/automation3030021
- Rayna, T., & Striukova L. (2016). From rapid prototyping to home fabrication: How 3D printing is changing business model innovation. *Technological Forecasting and Social Change*, 102, 214-224, doi: 10.1016/j.techfore.2015.07.023
- RepRap GPL Licence - RepRap, from <https://reprap.org/>, accessed January 5, 2024.
- Safeea, M., Bearee, R., & Neto, P. (2022). An integrated framework for collaborative robot-assisted additive manufacturing. *Journal of Manufacturing Processes*, 81, 406–413. doi: 10.1016/j.jmapro.2022.06.067
- Salmi, M. (2021). Additive Manufacturing Processes in Medical Applications. *Materials*, 14(1), 191. doi: 10.3390/ma14010191

- Sari, T., Gules, H. K., & Yigitol, B. (2020). Awareness and readiness of Industry 4.0: The case of Turkish manufacturing industry. *Advances in Production Engineering & Management*, 15(1), 57-68, doi: 10.14743/apem2020.1.349
- Shahrubudin, N., & Lee, T.C. (2019). Ramlan R., An Overview on 3D Printing Technology: Technological, Materials, and Applications. *Procedia Manufacturing*, 35, 1286–1296. doi: 10.1016/j.promfg.2019.06.089
- Strataysys Demonstrators, from <https://www.strataysys.com/demonstrators>, accessed March 12, 2024.
- Weilu, C., & Yinghui, L. (2024). Clinical application of additive manufacturing technology. *Chinese Journal of Tissue Engineering Research*, 28(17), 2782–2788. doi: 10.12307/2024.447
- Woźniak, J., Budzik, G, Przeszlowski, Ł., & Chudy-Laskowska, K. (2021). Directions of the Development of the 3D Printing Industry as Exemplified by the Polish Market. *Management and Production Engineering Review*, 12, 98-106. doi: 10.24425/mper.2021.137682
- Zhang, Y., Poli, L., Garratt, E., Foster, S., & Roch, A. (2020). Utilizing Fused Filament Fabrication for Printing Iron Cores for Electrical Devices. *3D Printing and Additive Manufacturing*, 7(6), 279–287, doi: 10.1089/3dp.2020.0136
- Zimon, D., Madzik, P., & Sroufe, R. (2020). Management systems and improving supply chain processes: Perspectives of focal companies and logistics service providers. *International Journal of Retail & Distribution Management*, 48(9), 939-961.

Joanna Woźniak

Rzeszow University of
Technology,
Faculty of Management,
Rzeszów, Poland
j.wozniak@prz.edu.pl
ORCID 0000-0002-3186-6347

Andrzej Paszkiewicz

Rzeszow University of
Technology,
Faculty of Electrical and
Computer Engineering,
Rzeszów, Poland
andrzej.paszkiewicz@prz.edu.pl
ORCID 0000-0001-7573-3856

Grzegorz Budzik

Rzeszow University of
Technology,
Faculty of Mechanical
Engineering and Aeronautics,
Rzeszów, Poland
gbudzik@prz.edu.pl
ORCID 0000-0003-3598-2860

Łukasz Przeszlowski

Rzeszow University of
Technology,
Faculty of Mechanical
Engineering and Aeronautics,
Rzeszów, Poland
lprzeszl@prz.edu.pl
ORCID 0000-0002-1212-9069

Mateusz Kielbicki

Doctoral School of the Rzeszów
University of Technology,
Rzeszów, Poland
mateusz.kielbicki@gmail.com
ORCID 0000-0002-8116-4589

Dominik Zimon

University of Information
Technology and
Management in Rzeszow,
Rzeszow, Poland
dzimon@wsiz.edu.pl
ORCID 0000-0002-3097-5445
