



REVIEW

Different Techniques for Separation of Brackish Water

ANSHIKA RANI¹, S. SURESH^{1*} and ANIL KUMAR²

¹Biochemical and Energy Engineering Lab, Department of Chemical Engineering, Maulana Azad National Institute of Technology, Bhopal-462003, India

²Energy Centre, Maulana Azad National Institute of Technology, Bhopal-462003, India

*Corresponding author: E-mail: sureshpecchem@gmail.com; amitansh2106@gmail.com

Received: 27 July 2018;

Accepted: 14 August 2018;

Published online: 30 November 2018;

AJC-19153

The lack of water is usually depicted in volumetric or absolute terms. The most scarcity studies focus on how the 'problem' of scarcity is raised, therefore to overcome this issue the first step is heating of an air stream by using solar energy for heating of an air stream and in the next step to seawater adding into the hot air in imperative to moisten, then final step is a humid air cooling providing potable water as a condensate. The conventional technique for seawater desalination is to vapourize salty water and afterward condense the rising vapour being free of salt. Using fossil fuels as an energy source, these desalination plants are planned as multi-stage evaporator plants. This technique is the foundation for a day-to-day production of million cubic meters of water. This review is focused on the performance analysis of different techniques such as multistage flash distillation, multi-effect distillation, vapour-compression distillation, solar humidification, electro dialysis reversal, reverse osmosis, nanofiltration, forward osmosis, solar desalination for separation of brackish water. Based on literature discussion with their remarks from different techniques, solar desalination has achieved 87 % of efficiency and lower the total dissolved solids content as 40 ppm. Moreover, cost of distilled water per liter \$ 0.029 from solar desalination plant. With this advantages, solar desalination has more attractive technique while compare to other towards better future and balanced eco-system.

Keywords: Desalination, Brackish water, Multi-effect distillation, Humidification-dehumidification, Membrane distillation.

INTRODUCTION

Desalination is a convenient process to develop a fresh water supply in coastal areas. Reverse osmosis and conventional thermal distillation can be used for implementing the large-scale seawater desalination. Desalination is the process in which fresh water is formed from seawater or brackish water by removing dissolved salt, to make it suitable for human consumption. A high yield of disposable water is manufactured by the desalination process. Desalination permits a widening in the utilization of existing water sources by manufacturing freshwater from briny water sources. Fig. 1 shows the process for the desalination system. Over the past era, in many parts of the world, conventional water production costs have been rising and costs for desalination have been abating, subsequently desalination has turned out to be all the more financially appealing and competitive [1,2].

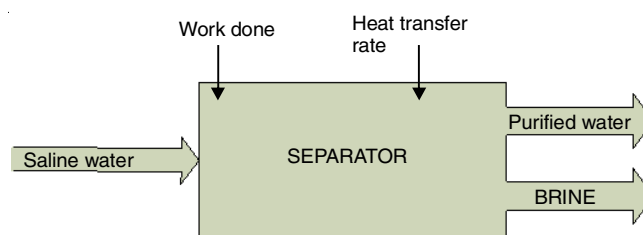

Fig. 1. Schematic diagram of a work-driven desalination system [Ref. 2]

Water shortage has become a noteworthy issue in many part of the world. Evaporated water from sources is caused by increasing in global temperature, by which it leads unescapably reducing in drinkable water amount, hence perversely growing in fresh water need and if safety measures not used then difficulty would possibly threat us in future [3]. Seawater desalination is seems to be most sensible method to the solution of fresh water supply. All desalting procedures certainly need energy to remove salty

contain from seawater and purify it. If desalting is consummate by conservative technology, then it will need the considerable amounts burning of fossil fuels [3,4]. Fig. 2 represents the worldwide feed water percentage used in desalination.

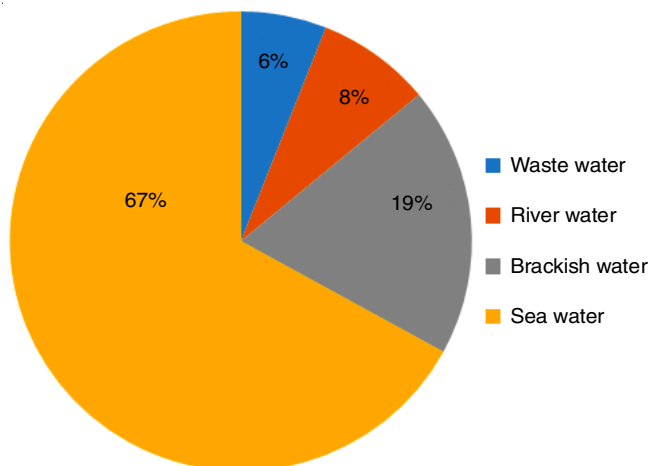

Fig. 2. Worldwide feed-water percentage used in desalination [Ref. 4]

Mehta [5] claimed that scarcity is not unavoidably 'natural'. As an alternative, it mentions to a concrete age of dearth either of water, milk which is felt extremely by the human and livestock population in rural areas. Numerous approaches, rooted in local knowledge systems and practice, exist to manage with sea-

sonality and rural livelihoods have amended to the variable and uncertain nature of Kutch's rainfall (desert area). The managing strategies against scarcity are significantly differentiated. The affluent of the village tend to have the most options and can resort to a wider range of managing strategies than the poor. To a certain extent, social forms of differentiation such as caste, historical legacies and gender legitimize the inadequate access to and control over scarce resources. These are the 'lived and experienced' phases of scarcity. Indirect used solar energy by means of solar, thermal and photovoltaics (PVs) systems in tandem with desalination is the most appropriate technology. Direct used solar energy for desalination, such as solar stills is the simplest, oldest and maximum used technique. Solar energy is most cleanly, inexhaustible of entirely freely available energy resources and uses of solar energy made tremendous match by minimum temperature requirement of heat pump. The evaporator-collector wrapped up both energies *i.e.*, solar energy and ambient energy, because of the low working temperature [6]. This paper gives an overall review and technical assessments of various desalination systems for brackish water separator.

Types of desalination: Desalination is classified by the anticipated product and process (Fig. 3). Processes again assembled by means of that permit water to pass across membrane with no phase change like forward osmosis, reverse osmosis and methods that include phase change such as multi-effect distillation, multi-stage flash, passive vacuum desalination, solar still, humidification-dehumidification, membrane distillation, freezing-melting

TABLE-1

Methods	Wastewater	Parameters	Result	Ref.
MSFD	Seawater	Temperature- 90 °C Pressure- 22.3 kpa	-Single stage system and two stage system produces 5.54 kg water in 7.83 h and 8.66 kg in 7.7 h respectively	[8]
Multi effect distillation	Seawater	Inlet temperature-25 °C Outlet temperature-40 °C	Capacity of 100 m ³ /day	[29]
Multi-effect distillation-vapor compression	Seawater	Inlet temperature-25 °C Outlet temperature-48.6 °C Salinity ratio - 46 g/kg	Capacity of 4545 m ³ /day	[29]
Reverse osmosis	Synthetic water	Temperature- 50 °C. Power consumed Operating time	Retention of the membrane is > 95 % (hourly rate of permeate product - 140 L h ⁻¹)	[17]
Humidification-dehumidification	Brackish water	Brackish water temperature and mass flow rates	Highest freshwater yield - 0.873 kg m ⁻² d ⁻¹ at evaporative temperature 64.3 °C	[14]
Reverse osmosis	Seawater or brackish water	Capacity	Low capacity (5000 L/day).	[18]
Reverse osmosis	Seawater	Salt concentration, pH and flow rate	Model will help in control RO desalination plant	[30]
Humidification-dehumidification	Seawater	Air and seawater flow rate and heating temperature	Yield 63.6 kg/h, (water flow rate of 1000 kg/h)	[31]
Humidification-dehumidification	Seawater	Cut a length of efficiency Overall heat loss coefficient	-Cut the length of efficiency-0.47 -Air flow rate - 140 m ³ /h capacity 1000 L/day -Overall heat loss coefficient-1.60	[32]
Solar desalination	Salty water	Temperature-70 °C	-The maximum daily Efficiency 87 %. -Cost of distilled water per liter \$0.029. -A TDS (total dissolved solids) of fresher water - 40 ppm.	[33]
Reverse osmosis	Seawater	Pressure and flow rates	Optimum performance when power input is between 16 and 18 kWh and with pressures ranging between 57 and 67 b.	[34]
Solar desalination	Seawater	Performance ratio (pr) Coefficient of performance (cop)	pr 0.43- 0.88, average cop - 8 highest distillate production -1.38 kg/h.	[6]

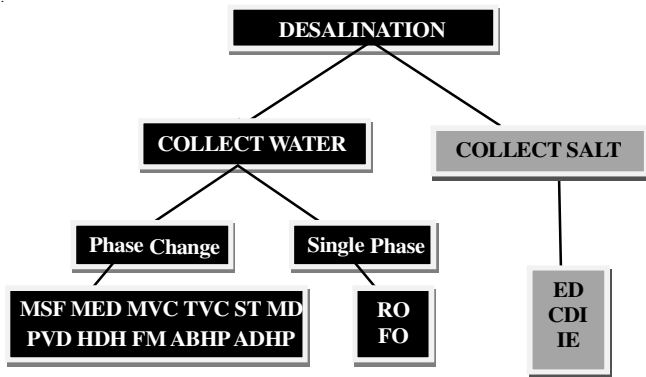

Fig. 3. Classification of desalination process [Ref. 10]

along with heat pump desalination applications with mechanical vapor compressor, thermal vapor compressor, adsorption heat pump desalination and absorption heat pump desalination techniques for takeout salt such as ion exchange, capacitive deionization and electrodialysis are usually used for brackish water desalination, not for seawater desalination [7]. Table-1 shows recent literature studies on separation of sea water or brackish or synthetic water and its process parameters.

Multiple stage flash distillation (MSFD): In multi-stage flash desalination system, the brine heater is used for heating the feed water over the saturation temperature and made to flash in container where low pressure is retained using a vacuum pump. Brine of the last phase is allowable to flash for succeeding phases and the vapors made in every phase are condensed and inlet salty water is heated here. In 1974, Federal Republic of Germany and Mexico developed a solar powered multi-stage flash desalination plant having capacity 10 m³/d with recirculation of brine. There were a parabolic trough collectors, double tube flat plate collector, storage tanks and desalination unit in

plant [7]. Maroo and Goswami [8] proposed a system where they used a flash evaporator, by which size of a system can be reduced. Heat input can be delivered from a renewable source like a solar collector and by a constant temperature waste-heat source. Sanaye and Asgari [9] have analyzed multi-objective optimization of a combined cycle power producing unit with a multi-stage flash desalination unit and Four E (exergy, energy, environmental and economic). They concluded that the power output and distillate production as well as payback and income period are affected by the variation of ambient temperature. They also concluded that the optimum value of design parameters was not dependent on the change in ambient temperature. single-stage flash desalination system is shown in Fig. 4.

Multiple-effect distillation (MED): Multi-effect distillation setup contains of vessels that are usually known as effects retained in succession at minimum pressure where salted water is sprinkled. Required heat for evaporation for initial phase is provided by burning of fossil fuel or else by solar energy the feed in the afterward significance is heated by the formed vapors. Therefore, latent heat of formed vapors in the previous phase are successfully applied for afterward phase of multi-effect distillation. Because good compatibility of it with solar thermal desalination (STD) these systems are achieving more market share [7]. Solar-powered multi-effect distillation system is shown in Fig. 5. Padilla *et al.* [11] deal with the design of solar thermal desalination (STD) system established on a multi-effect distillation plant attached to a double-effect absorption heat pump. They found that overall performance ratio was 20, which outcome in 50% lessening of the needed solar field area compared with solar multi-effect distillation system. Gabriel *et al.* [12] used linear programming to optimize multi-effect distillation. Their analysis was based on the effects of various system parameters like seawater salinity, heating costs, motive steam

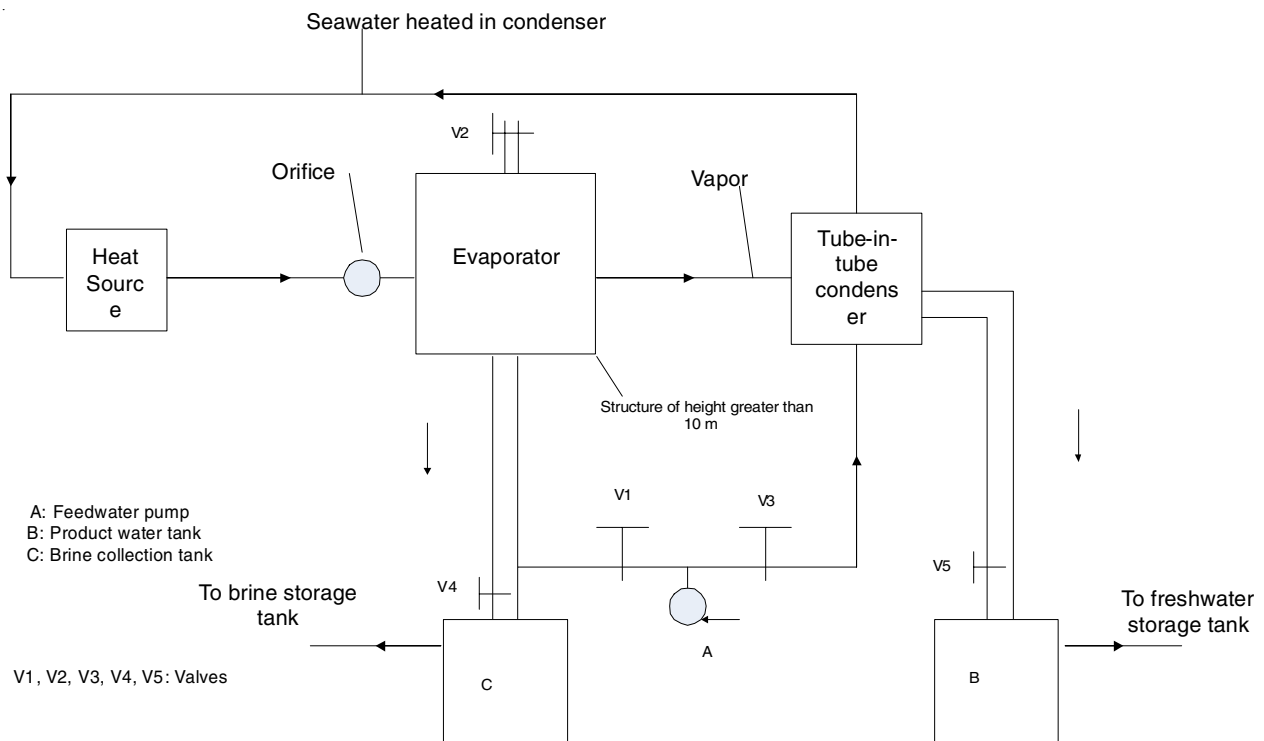

Fig. 4. Single-stage flash desalination system [Ref. 8]

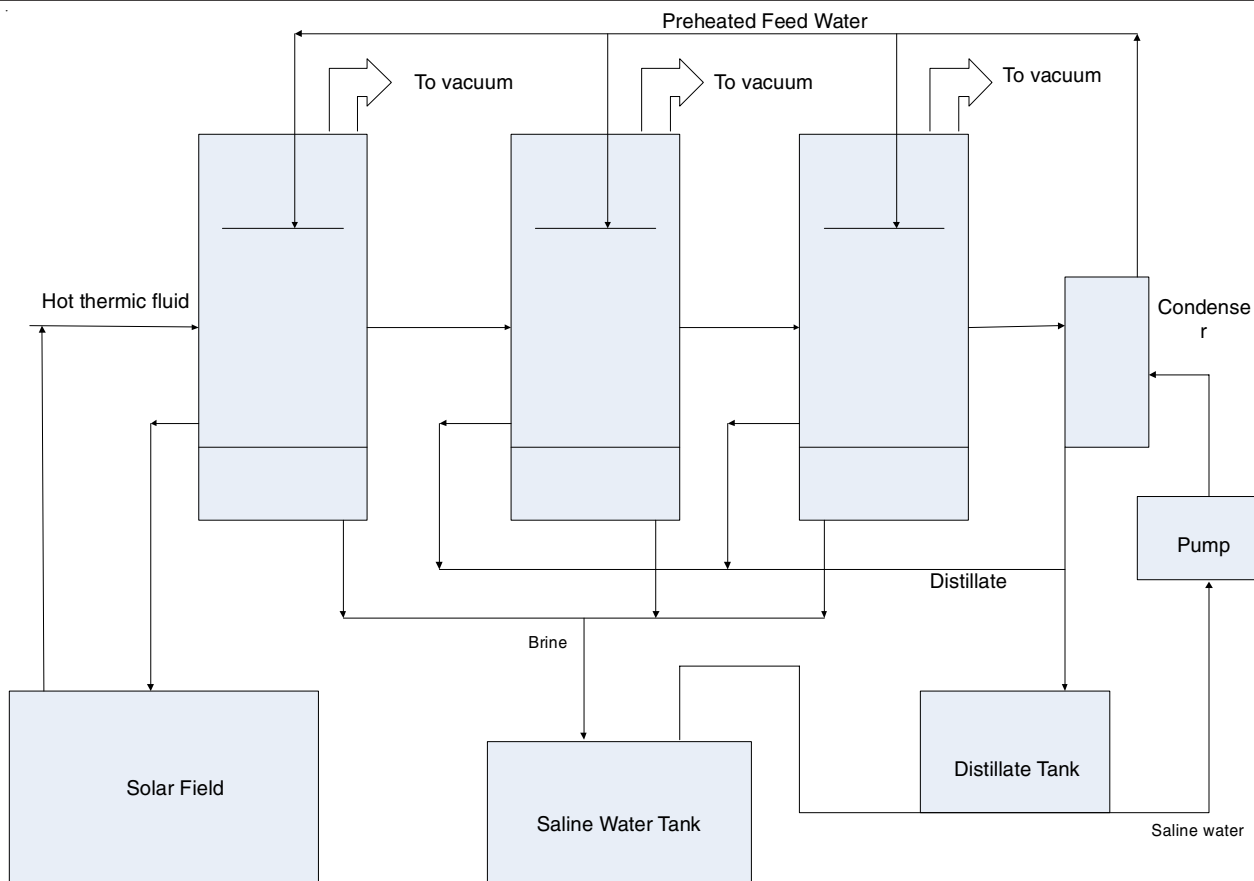

Fig. 5. Solar powered multi-effect distillation system [Ref. 7]

supply pressure, and the number of operating effects on the thermo-economically optimum design.

Vapor-compression desalination: Vapor compression desalination is a process in which the evaporation of water is found by the use of heat applied by compressed vapor. While the temperature and pressure of vapor are increased by vapor's compression, to generate additional vapor and it is possible to make use of latent heat discarded in the duration of condensation. In vapor-compression desalination, outer heat source is used to heat the feed water and then it permitted to flash the vapors, therefore formed vapors are compressed by mechanical vapor compression or thermal vapor compression to increase the condensation temperature and pressure of the vapor and compressed vapor are utilized to heat the same phase or feed of other phases [7]. Schematic image of mechanical vapor compression desalination unit is shown in Fig. 6. Sharaf *et al.* [13] investigated two methods of solar power cycles to power, mechanical vapor compressor (MVC) and multi-effect distillation thermal. They concluded that the increasing the evaporator's numbers with decreasing value of compression ratio would decrease the power consumption and the gain ratio is increased by the operation of steam ejector as an alternative of increasing the evaporator's numbers. They suggested that when it functions at low top brine temperature (TBT), mechanical vapor compressor (MVC) has benefit of consuming a low-temperature heat source hence this can provide considerable lower equivalent work and presented spent energy than multi-stage flash (MSF) units.

Solar humidification: The key idea of solar humidification-dehumidification (HDH) process is which, with the moisture

carrying ability of air is increased as temperature increased. When hot air heated solar collector circulated in natural/forced way, comes in contact to feed water which is sprinkled in the evaporator, certain amount of vapors are pull out by the air and that vapors could be recovered by condenser where feed water is preheated. Four kinds of HDH desalination patterns are closed air, open water cycle; closed air, closed water cycle; open air, open water cycle and open air, closed water cycle (Fig. 7) [7]. Wang *et al.* [14] studied a photovoltaic panel-driven HDH handling process for desalination of feed under a free/forced convection mode. The free convection mode consummate a minimum freshwater yield than the forced convection mode. With the forced convection, at evaporative temperature $T_0 = 64.3^\circ\text{C}$, the maximum freshwater yield was $0.873\text{ kg/m}^2\text{d}$ attained. They also examined the cost analysis (preliminary) and showed that the water formed by free convection from this type of HDH desalination process had a cost similar to that of potable water from commercial water plants. It is found that for desalination of brackish water through HDH treatment is feasible in both ways; technically and economically.

Electrodialysis reversal: Electrodialysis reversal is the procedure where removal of salts from salty water occur and the electrodialysis division contains of a huge number of sections occupied with feed water and detached by anion and cation conversation membranes. By application of DC polarity through the anode/cathode, the positive ions passes across the cation exchange membrane and negative ions go across the anion exchange membrane and these ions get gathered in the precise section and are drained out as brine. To avoid deposition of salts in the membranes, reversal of polarity is normally

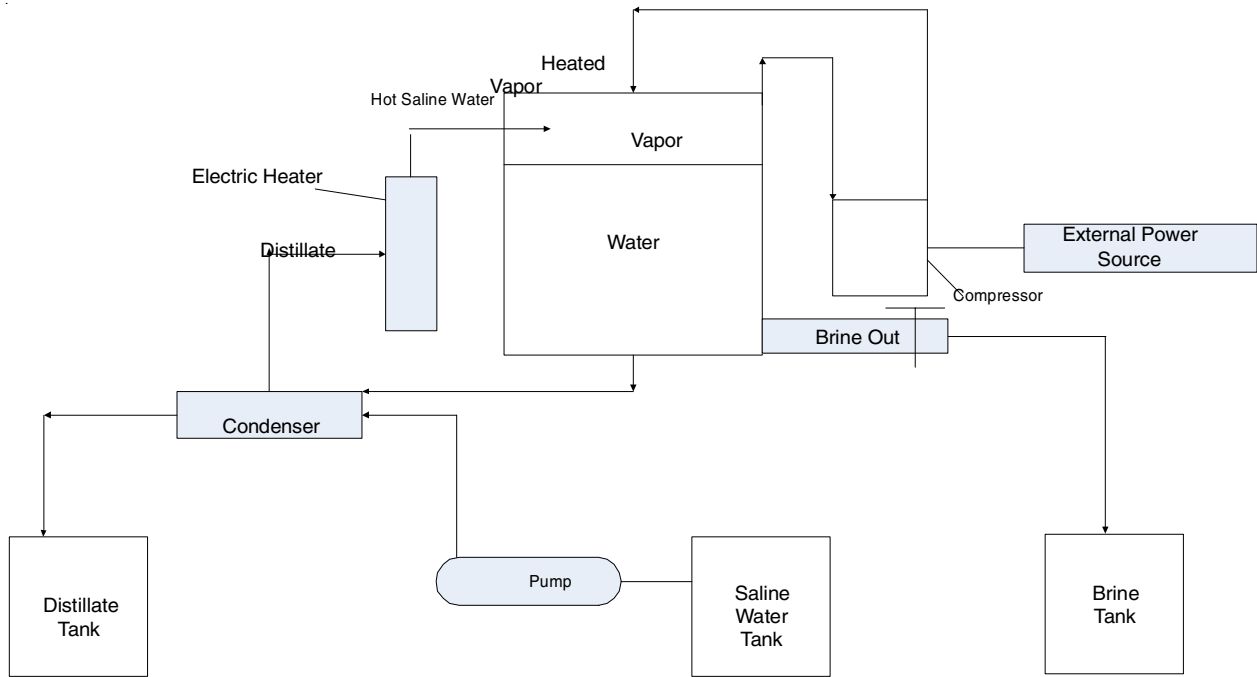

Fig. 6. Mechanical vapor compression desalination system [Ref. 7]

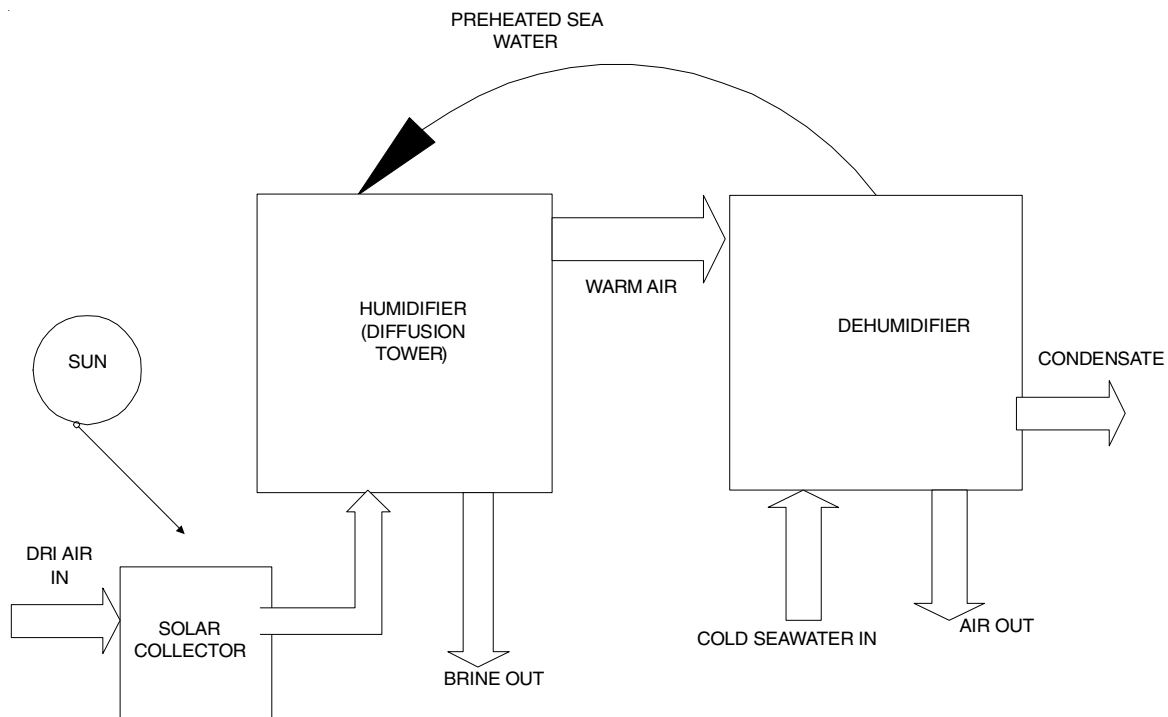

Fig. 7. A simple humidification–dehumidification (HDH) process [Ref. 16]

followed every 20 min [7]. Solar PV powered electro dialysis unit is shown in Fig. 8. Guolin *et al.* [15] designed an electro dialysis set up and the optimum operating conditions and the maximum treatment capacity of the tested setup were investigated. The maximum capacity of the four-grade and four-segment reversal electro dialysis four-GS ED setup for treating polymer flooding produced water was 5 m³/h. The most promising operating condition and outcomes were at an operating electric current of 86 A, 62.5 % production rate of diluted treated polymer-flooding produced water, 0.89 kWh/m³ energy consumption and 78.7 % total dissolved solids removal rate.

Reverse osmosis: It is a procedure which is driven by pressure, in which feed in pressurized form, is permitted to pass across the cross-flow membrane module. Fresh water permeates across the membrane, if the osmotic pressure is lower than applied pressure. It is collected across the permeate tube and the brine is drained out [7]. Soric *et al.* [17] suggested that the continuous making of desalinated water in the demand of 1 m³/day could lead by development of an effective energy regulator. Muñoz and Becerril [18] identified 28 localities in 10 Mexican states and in these localities, solar energy can be used in the brackish or water seawater desalination using solar photovoltaic energy. The proposed solar photo-

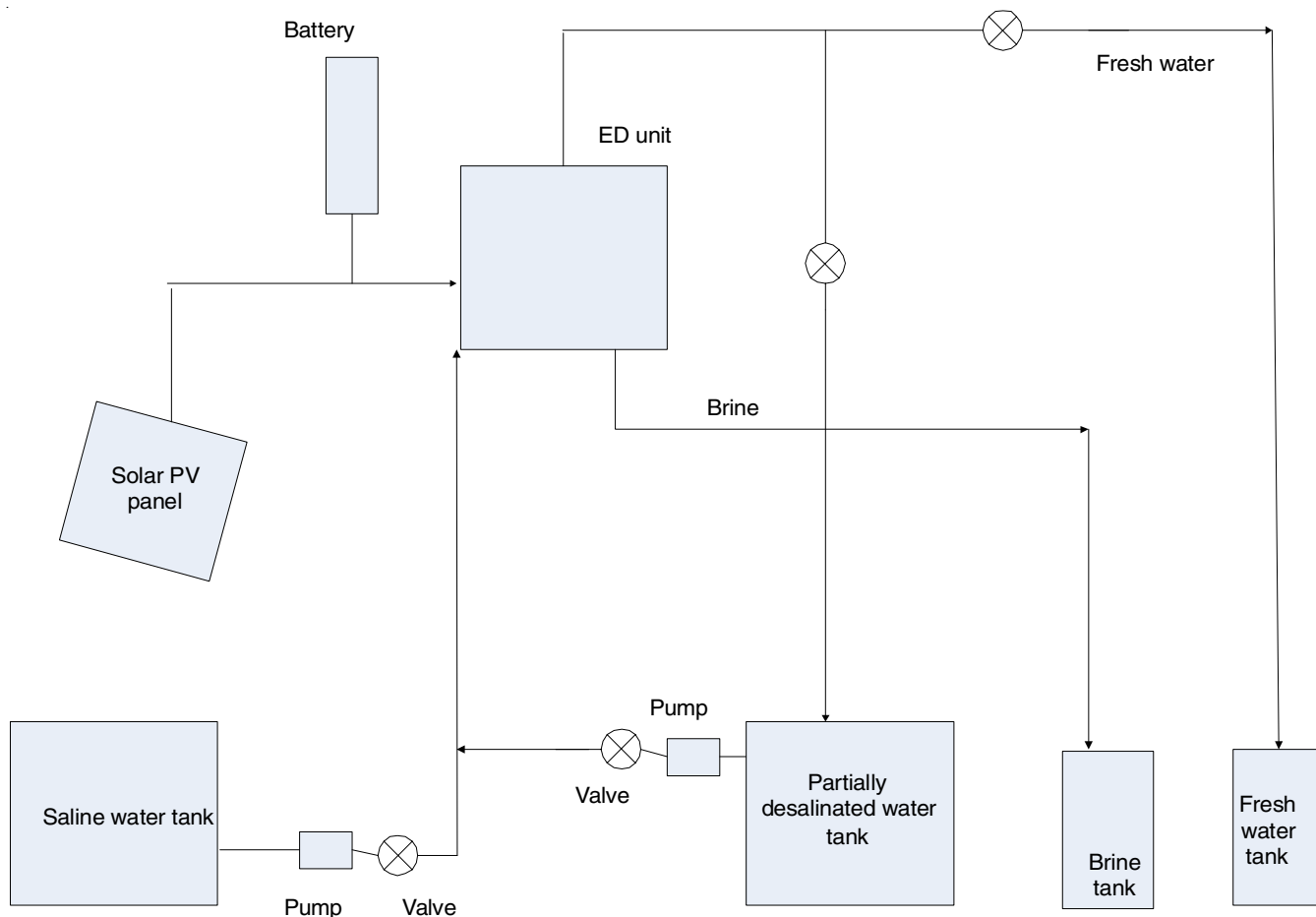

Fig. 8. Solar PV powered ED unit [Ref. 7]

voltaic desalination uses reverse osmosis since the technology is quite known and can be adapted to low capacities. Later, a literature review determined that, currently, the proposed desalination outline must be of low capacity (5000 L/day). Parabolic trough coupled with seawater reverse osmosis desalination unit is shown in Fig. 9.

Mokheimer *et al.* [19] has been modeled and simulated an integrated wind/solar powered reverse osmosis desalination setup. The performance of the setup has been studied under Dhahran (Saudi Arabia) climate data for a typical year. The performance has been examined under a constant reverse osmosis load of 1 kW for 12 h/day and 24 h/day. Simulation results presented that optimal system, that powers a 1 kW reverse osmosis system for 12 h/day that yields a minimum levelized cost of energy includes 6 batteries, 2 wind turbines and 40 photovoltaic modules and the levelized cost of energy of the system is invented to be 0.624 \$/kWh. On the other hand, for a load of 1 kW for 24 h/day, the optimal system contains 6 wind turbines, 16 batteries and 66 photovoltaic modules with a least cost of energy 0.672 \$/kWh. The energy utilized for desalination ranges between 8-20 kWh/m³, depending on the raw water salinity, this shows that expenditure will be between \$ 3.693/m³ and \$ 3.812/m³, which is minimum than the range stated in the literature with the proposed optimum hybrid wind/solar system for water desalination.

Nanofiltration: Nanofiltration is a method that is independent on the interfacial events and micro hydrodynamic arising at the surface of membrane and in membrane nanopores. Rejection

from nanofiltrate membranes may be accredited to a grouping of steric, donnan, transport and dielectric effects. The transport of neutral solutes is *via* steric mechanism and has been well established by numerous studies of ultrafiltration membranes [20]. Fig. 10 shows the schematic diagram of experimental nanofiltration set-up. Liu *et al.* [21] performed the energy analysis of dual-stage nanofiltrate seawater desalination. The energy devastation in the process happened into the concentration stream valves and membrane. Recovery ratio of system was increased to reach 42.78 % and calculated specific energy used was decreased upto 2.09 kWh/m³, under the condition specified. Thus, the development of an energy recovery device and a novel energy saving membrane module is important in reducing energy depletion in dual-stage nanofiltration seawater desalination [22].

Forward osmosis: Forward osmosis is a method where the saline water molecules pass by the semi-permeable membrane in the direction of draw solution that is kept at the greater concentration than the feed water. Hydraulic pressure gradient is not used by forward osmosis, it mainly uses osmotic pressure gradient (Fig. 11) [7]. Using nanofiltration, forward osmosis-nanofiltration (FO-NF) and reverse osmosis, Zhao *et al.* [23] compared desalination of feed water (brackish) with salinity of 3970 mg/L. They used cellulose triacetate forward osmosis membrane BW30LE (poly-amide TFC) and NF270 (polyamide TFC) flat sheet membranes for reverse osmosis and nanofiltration. Reverse osmosis process requires high pressure of 30 bar and direct nanofiltration was not appropriate for treatment of brackish

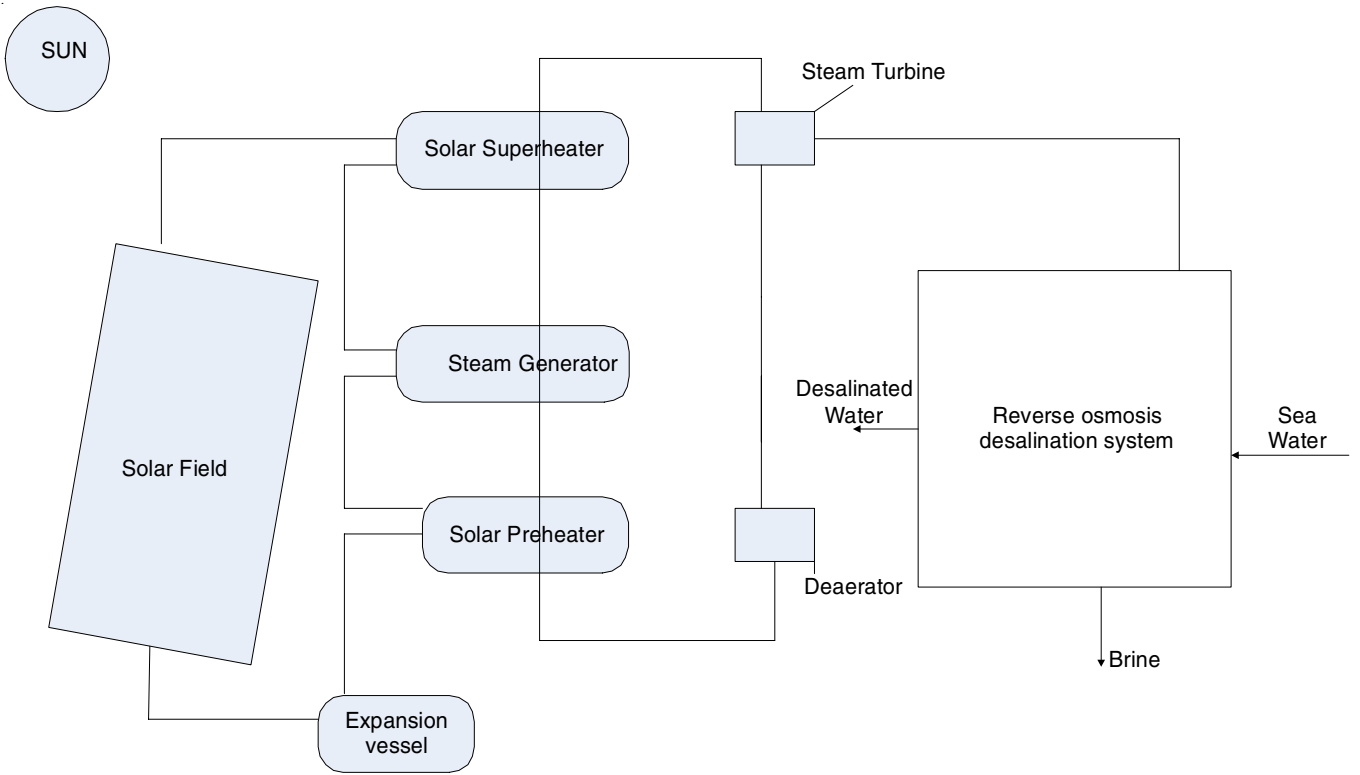

Fig. 9. Parabolic trough coupled with seawater reverse osmosis desalination unit [Ref. 4]

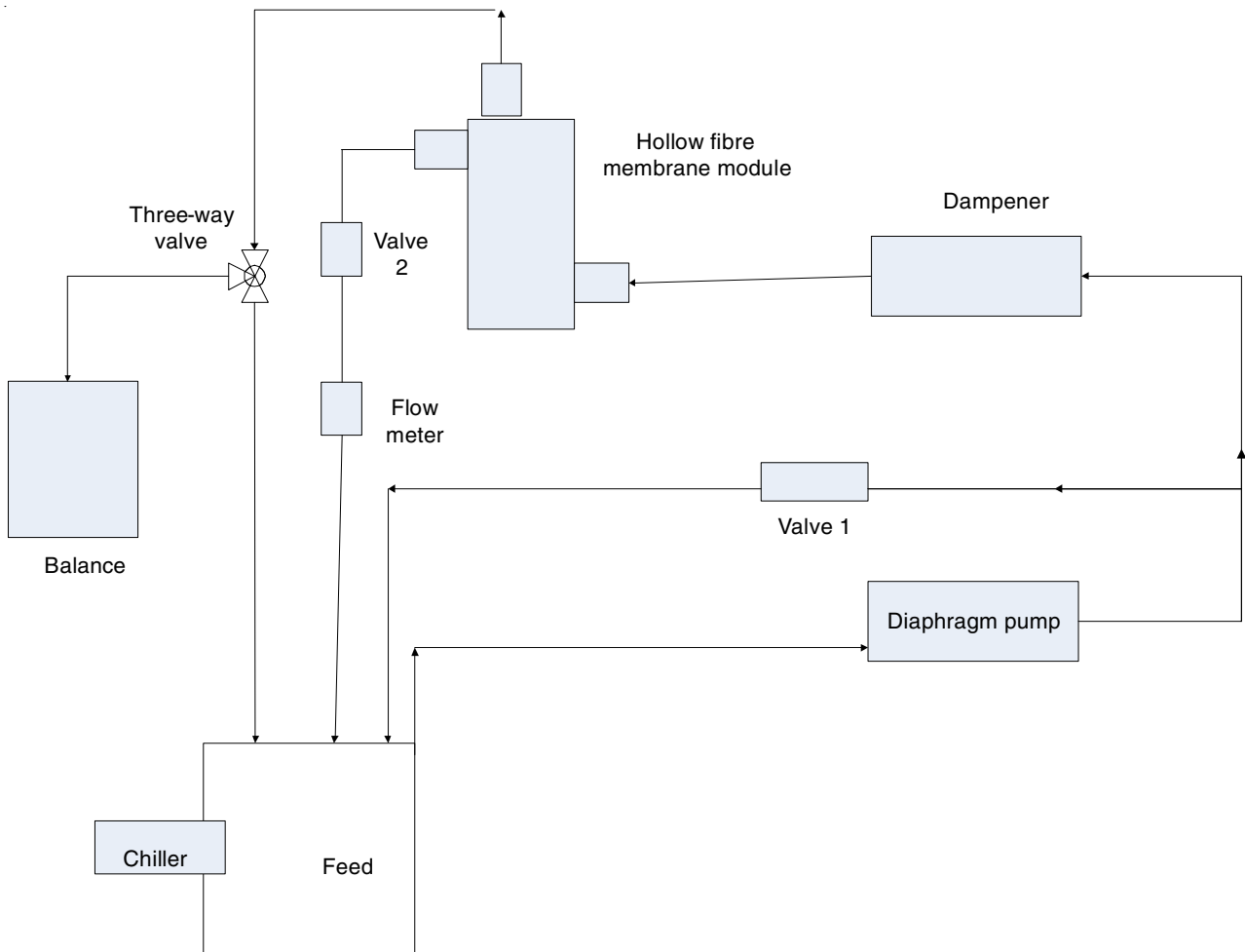

Fig. 10. Schematic diagram of the experimental nanofiltration set-up [Ref. 21]

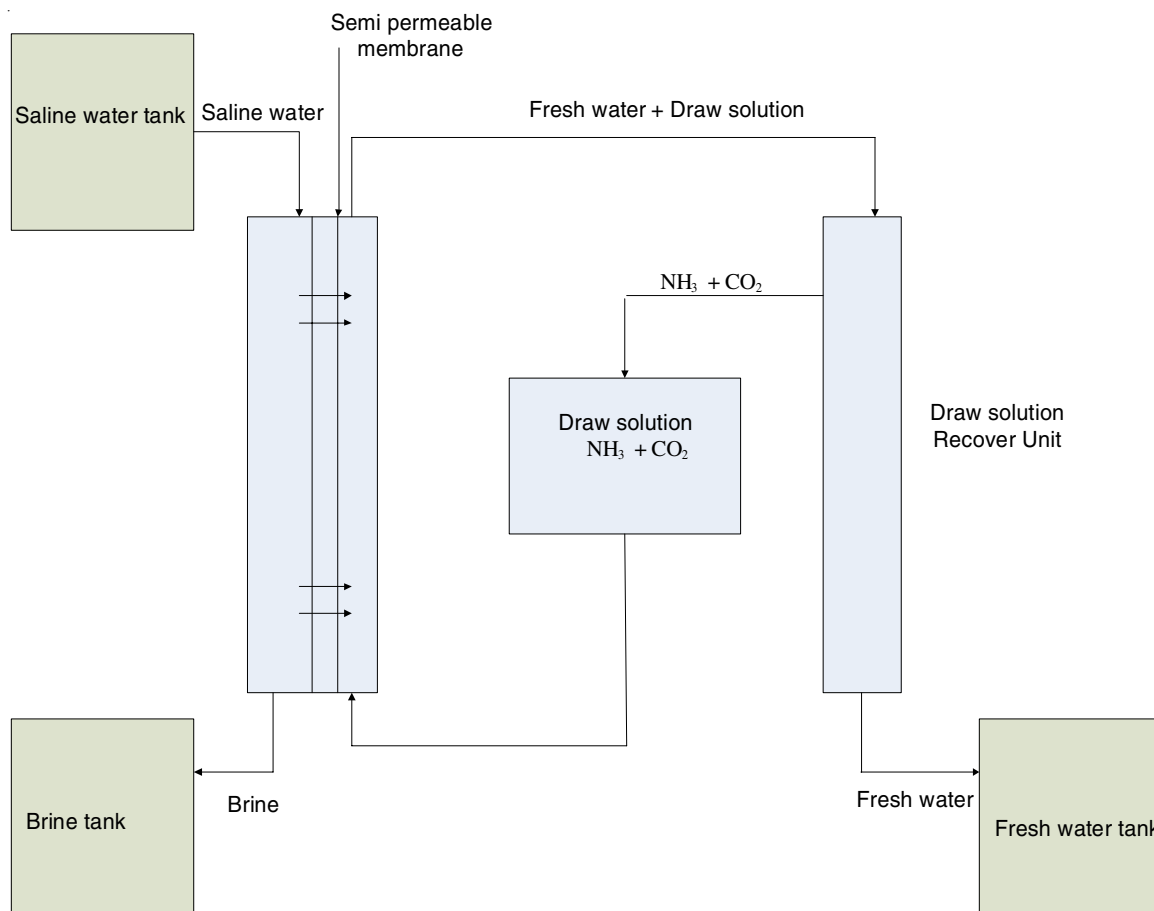

Fig. 11. Forward osmosis unit using $\text{NH}_3\text{-CO}_2$ as draw solution [Ref. 7]

water. Forward osmosis unit which uses 1.5 M Na_2SO_4 solution as draw solution was found to be a better option for treatment of brackish water. Brackish water molecules circulates into the draw solution (due to osmotic pressure difference) resultant in the dilution of Na_2SO_4 solution that was again desalted using nano-filtration to acquire fresh water. Li *et al.* [24] investigated composite polymer hydrogel as draw agent for forward osmosis. Composite polymer hydrogel as made by including carbon particles and size of the ready hydrogels lies between 100-200 mm and 500-700 mm. NaCl solution was utilized as feed solution and ready hydrogel was kept on the active side of semi-permeable membrane. The feed water solution pass across the membrane and gets absorbed by polymer hydrogel makes it swell and external can recover the water.

Solar desalination: India, a tropical nation is honored with plenty of sunshine. Normal daily solar radiation fluctuates between 4-7 kWh/m² for various portions of the nation. There are average 250-300 apparent sunny days in a year and it gets around 5000 trillion kWh of solar energy in a year [25]. Solar energy is an independent endless energy resource for ground-water desalination; having low running costs and decrease the contribution of greenhouse gases to global warming. In remote zones, perfect meteorological conditions and land space are accessible, where solar desalination could give freshwater to drinking, for the nursery, farming industries and for greenhouse agriculture [26].

Solar desalination is a method to desalting the water by solar energy. Attaining desalination by this procedure, there

are two important methods; direct and indirect. In the direct method, a solar collector is attached with a desalting mechanism and the procedure is in one simple cycle. These type solar stills are engaged in several low scale desalination plants, defined in survival guides and provided in oceanic survival kits. In this method incidence angle, area of solar surface effects the production of water and has an estimated value of 3-4 L/m²/day. Because of this proportionality and the relatively high cost of material for construction this method have a tendency to favor plants having manufacture capacities less than 200 m³/day. And the other one is indirect method, it consists two detached arrangements, solar collection unit and a detached commercial distillation plant. Water production from this method is independent on the cost per unit produced and efficiency of the plant [27].

The life cycle cost analysis of single slope hybrid active solar still has been performed by Kumar and Tiwari [28] and they reported that for longer sunshine hours, greater solar radiation and a number of shiny days in a year, the cost of production and the payback periods can further be reduced. They found that with the interest rate increase from 4 to 12 %, gained distillate's cost per kg from a passive solar still increases nearly 1.7 times also hybrid active solar still's annual yield is 3.5 times greater than passive solar still. El-Agouz [33] studied one stage method to potable water production by enhancing evaporation and condensation. Schematic view of solar water desalination unit is shown in Fig. 12. They concluded that the flow rate and inlet hot water temperature are strongly affected the efficiency, productivity, gained output ratio and productivity rate of the solar desalination unit.

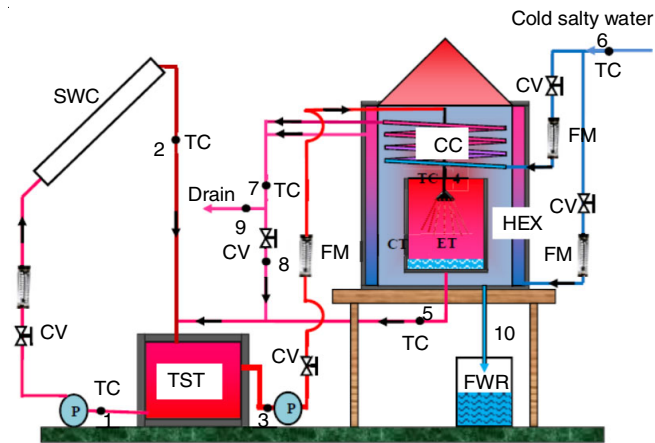

Fig. 12. Schematic view of the solar water desalination unit [Ref. 33]

Conclusion

In this review, based on the studied desalination systems, it is concluded that the solar desalination is the most cost effective technology among all the other commercial technologies, as this technique does not depend upon the usage of fuel. This technique is ecofriendly for treatment of wastewater. The obtained water quality from solar desalination can be used for drinking and industrial purposes. Hence no possibility of pollution and bacterial contaminations. It is further suggested that the solar desalination technique can be used for the large scale applications with active effects units.

ACKNOWLEDGEMENTS

One of authors, Anshika Rani is thankful to Ministry of Human Resources and Development (MHRD) and Maulana Azad National Institute of Technology (MANIT) Bhopal, India for providing research fellowship and other facilities for completing this work.

CONFLICT OF INTEREST

The authors declare that there is no conflict of interests regarding the publication of this article.

REFERENCES

1. S. Burn, M. Hoang, D. Zarzo, F. Olewnaik, E. Campos, B. Bolto and O. Barron, *Desalination*, **364**, 2 (2015); <https://doi.org/10.1016/j.desal.2015.01.041>.
2. J.H. Lienhard, M.A. Antar, A. Bilton, J. Blanco and G. Zaragoza, Solar Desalination, In: Annual Review of Heat Transfer, Begell House Inc., Chap. 9, pp. 277-347 (2012).
3. Ý.H. Ýýlmaz and M.S. Söylemez, *Desalination*, **291**, 23 (2012); <https://doi.org/10.1016/j.desal.2012.01.022>.
4. A.A. Al-Karaghoul and L.L. Kazmerski, ed.: M. Schorr, Renewable Energy Opportunities in Water Desalination, In: Desalination, Trends and Technologies, InTech (2011).
5. L. Mehta, *Land Use Policy*, **24**, 654 (2007); <https://doi.org/10.1016/j.landusepol.2006.05.009>.
6. Z.M. Amin and M.N.A. Hawlader, *Renew. Energy*, **74**, 116 (2015); <https://doi.org/10.1016/j.renene.2014.07.028>.
7. H. Sharon and K.S. Reddy, *Renew. Sustain. Energy Rev.*, **41**, 1080 (2015); <https://doi.org/10.1016/j.rser.2014.09.002>.
8. S.C. Maroo and D.Y. Goswami, *Desalination*, **249**, 635 (2009); <https://doi.org/10.1016/j.desal.2008.12.055>.
9. S. Sanaye and S. Asgari, *Desalination*, **320**, 105 (2013); <https://doi.org/10.1016/j.desal.2013.04.023>.
10. C. Li, Y. Goswami and E. Stefanakos, *Renew. Sustain. Energy Rev.*, **19**, 136 (2013); <https://doi.org/10.1016/j.rser.2012.04.059>.
11. D.C. Alarcón-Padilla, L. García-Rodríguez and J. Blanco-Gálvez, *Desalination*, **262**, 11 (2010); <https://doi.org/10.1016/j.desal.2010.04.064>.
12. K.J. Gabriel, P. Linke and M.M. El-Halwagi, *Desalination*, **365**, 261 (2015); <https://doi.org/10.1016/j.desal.2015.03.011>.
13. M.A. Sharaf, A.S. Nafey and L. García-Rodríguez, *Energy*, **36**, 2753 (2011); <https://doi.org/10.1016/j.energy.2011.02.015>.
14. J.H. Wang, N.Y. Gao, Y. Deng and Y.L. Li, *Desalination*, **305**, 17 (2012); <https://doi.org/10.1016/j.desal.2012.08.008>.
15. J. Guolin, X. Lijie, L. Yang, D. Wenting and H. Chunjie, *Desalination*, **264**, 214 (2010); <https://doi.org/10.1016/j.desal.2010.06.042>.
16. G.P. Narayan, M.H. Sharqawy, E.K. Summers, J.H. Lienhard, S.M. Zubair and M.A. Antar, *Renew. Sustain. Energy Rev.*, **14**, 1187 (2010); <https://doi.org/10.1016/j.rser.2009.11.014>.
17. R. Soric, R. Cesaro, P. Perez, E. Guiol and P. Moulin, *Desalination*, **301**, 67 (2012); <https://doi.org/10.1016/j.desal.2012.06.013>.
18. F. Muñoz and L.A. Becerril, *Energy Procedia*, **57**, 2787 (2014); <https://doi.org/10.1016/j.egypro.2014.10.311>.
19. E.M.A. Mokheimer, A.Z. Sahin, A. Al-Sharafi and A.I. Ali, *Energy Convers. Manage.*, **75**, 86 (2013); <https://doi.org/10.1016/j.enconman.2013.06.002>.
20. A.W. Mohammad, Y.H. Teow, W.L. Ang, Y.T. Chung, D.L. Oatley-Radcliffe and N. Hilal, *Desalination*, **356**, 226 (2014); <https://doi.org/10.1016/j.desal.2014.10.043>.
21. J. Liu, J. Yuan, L. Xie and Z. Ji, *Energy*, **62**, 248 (2013); <https://doi.org/10.1016/j.energy.2013.07.071>.
22. X. Li, C. Zhang, S. Zhang, J. Li, B. He and Z. Cui, *Desalination*, **369**, 26 (2015); <https://doi.org/10.1016/j.desal.2015.04.027>.
23. S. Zhao, L. Zou and D. Mulcahy, *Desalination*, **284**, 175 (2012); <https://doi.org/10.1016/j.desal.2011.08.053>.
24. D. Li, X. Zhang, J. Yao, Y. Zeng, G.P. Simon and H. Wang, *Soft Matter*, **7**, 10048 (2011); <https://doi.org/10.1039/c1sm06043k>.
25. T.V. Arjunan, H.S. Aybar and N. Nedunchezian, *Renew. Sustain. Energy Rev.*, **13**, 2408 (2009); <https://doi.org/10.1016/j.rser.2009.03.006>.
26. M.G. Salim, *J. Adv. Res.*, **3**, 11 (2012); <https://doi.org/10.1016/j.jare.2011.02.008>.
27. https://en.wikipedia.org/wiki/Solar_desalination.
28. S. Kumar and G.N. Tiwari, *Appl. Energy*, **86**, 1995 (2009); <https://doi.org/10.1016/j.apenergy.2009.03.005>.
29. M.A. Sharaf, A.S. Nafey and L. García-Rodríguez, *Desalination*, **272**, 135 (2011); <https://doi.org/10.1016/j.desal.2011.01.006>.
30. S. Subramani and R.C. Panda, *Desalination*, **351**, 120 (2014); <https://doi.org/10.1016/j.desal.2014.07.038>.
31. Z. Chang, H. Zheng, Y. Yang, Y. Su and Z. Duan, *Renew. Energy*, **69**, 253 (2014); <https://doi.org/10.1016/j.renene.2014.03.048>.
32. X. Li, G. Yuan, Z. Wang, H. Li and Z. Xu, *Desalination*, **351**, 1 (2014); <https://doi.org/10.1016/j.desal.2014.07.008>.
33. S.A. El-Agouz, G.B.A. El-Aziz and A.M. Awad, *Energy*, **76**, 276 (2014); <https://doi.org/10.1016/j.energy.2014.08.009>.
34. F.J. García Latorre, S.O. Pérez Báez and A. Gómez Gotor, *Desalination*, **366**, 146 (2015); <https://doi.org/10.1016/j.desal.2015.02.039>.