

Impact Factor:

ISRA (India) = 4.971
ISI (Dubai, UAE) = 0.829
GIF (Australia) = 0.564
JIF = 1.500

SIS (USA) = 0.912
PIHII (Russia) = 0.126
ESJI (KZ) = 8.997
SJIF (Morocco) = 5.667

ICV (Poland) = 6.630
PIF (India) = 1.940
IBI (India) = 4.260
OAJI (USA) = 0.350

SOI: [1.1/TAS](#) DOI: [10.15863/TAS](#)

International Scientific Journal Theoretical & Applied Science

p-ISSN: 2308-4944 (print) e-ISSN: 2409-0085 (online)

Year: 2020 Issue: 11 Volume: 91

Published: 17.11.2020 <http://T-Science.org>

QR – Issue



QR – Article



Dmitry Olegovich Bordukh

Institute of service and entrepreneurship
bachelor's degree.

Artur Alexandrovich Blagorodov

Institute of service and entrepreneurship
bachelor's degree

Vladimir Prokhorov

Institute of service and entrepreneurship
(branch) DSTU in Shakhty, Russia
doctor of technical Sciences, Professor

Yuri Dmitrievich Mishin

Siberian state University of transport messages
Ph. D., Professor

Pavel Postnikov

Siberian state University of transport messages
candidate of technical Sciences, Professor
Novosibirsk, Russia

Galina Volkova

OOO SPOSN "Ortomoda"
doctor of Economics, Professor
Moscow, Russia

ON THE EFFECTIVENESS OF SIMULATION MODELS FOR THE PRODUCTION OF AFFORDABLE PRODUCTS FOR CONSUMERS IN THE DOMESTIC AND INTERNATIONAL MARKETS

Abstract: In the article, the authors analyze the effectiveness of the software developed by them for forming the technological process of production of import-substituting products and determining the specific reduced costs, which allows calculating the statistical parameters of the effective technological process of production of high-quality products in various forms of production organization, and the software developed by the authors for calculating the receipt of funds from the technological process of production of quality products guarantees light industry enterprises to obtain stable TA and prevent them from bankruptcy providing them with financial stability.

Key words: financial stability, stability, profitability, profit, demand, availability, quality, demand, competitiveness, import substitution, Union of Federal, regional and municipal branches of government; innovation, economic policy, industrial policy, assortment, assortment policy.

Language: English

Citation: Bordukh, D. O., et al. (2020). On the effectiveness of simulation models for the production of affordable products for consumers in the domestic and international markets. *ISJ Theoretical & Applied Science*, 11 (91), 201-226.

Soi: <http://s-o-i.org/1.1/TAS-11-91-34> **Doi:**  <https://dx.doi.org/10.15863/TAS.2020.11.91.34>

Scopus ASCC: 2000.

Impact Factor:

| | | | | | |
|------------------|---------|----------------|---------|--------------|---------|
| ISRA (India) | = 4.971 | SIS (USA) | = 0.912 | ICV (Poland) | = 6.630 |
| ISI (Dubai, UAE) | = 0.829 | ПИИИ (Russia) | = 0.126 | PIF (India) | = 1.940 |
| GIF (Australia) | = 0.564 | ESJI (KZ) | = 8.997 | IBI (India) | = 4.260 |
| JIF | = 1.500 | SJIF (Morocco) | = 5.667 | OAJI (USA) | = 0.350 |

Introduction

UDC 519.47 : 685.37

Simulation modeling today is becoming an increasingly mature technology of computer modeling, due to which there is a steady growth of applications of this method in a variety of areas related to management and decision-making of an economic, organizational, social and technical nature.

Imitation modeling involves the creation of a logical and mathematical model of a complex system. In imitation modeling, the logical structure of the modeled system is adequately displayed in the model, and the processes of functioning and the dynamics of interaction of its elements are reproduced (imitated) on the model. Therefore, the construction of a simulation model includes a structural analysis of the modeled system and the development of a functional model that reflects the dynamic portraits of the modeled system.

Another important specific feature of simulation as a type of simulation is that the method for studying a computer model here is a directed computational experiment, the content of which is determined by the analytical research and the corresponding computational procedures implemented both at the stage of strategic planning of the experiment and at the stage of processing and interpreting its results.

In the industrial field, simulation technology has been and is used quite widely; Currently, there is specialized software for simulation modeling in a number of industries: medicine, telecommunications, aviation and astronautics, electronics, textiles, pharmaceuticals, publishing, railways, government organizations.

For discrete simulation, automated systems are used that are invariant to the subject area, based on the description of processes (processdescription), in particular, the ARENA simulation package.

Simulation modeling is considered as a methodology and tool for solving problems of analysis and design of production systems and helps to avoid costly errors caused by the implementation of

extremely intuitive solutions; develop processes to deal with dead ends and uncertainties caused by randomness and variability in systems; discover hidden reserves and eliminate inhibiting factors in existing implementations and internal processes; to strengthen relationships with consumers by improving the quality of shoes and the speed of their manufacture.

For a detailed study of technological processes, process diagrams were built in the IDEF3 notation, with the help of which the process of developing technological processes for the production of footwear is described.

IDEF3 is a method that allows a technologist to describe a situation when processes are executed in a certain sequence, as well as to describe objects that participate together in one process. The IDEF3 dataset description technique is part of structural analysis. IDEF3 complements IDEF0 and contains all the necessary data for building models, which are further used for simulation analysis.

IDEF3 diagrams, which are then exported to simulation models for their subsequent "playback" and optimization, are shown in Figures 1-5. All diagram objects contain additional descriptions (equipment, auxiliary materials, performance standards), which can be automatically generated into a report, in essence, which is a flow chart of the operation. An example of a chart report is shown in Table 1.

Replacing a real experiment with simulation modeling allows you to reduce the costs necessary for conducting research. In addition, in some situations, experiments on real systems are often impossible due to the complexity of economic systems. The possibility of integrated use of the model developed in the BPWin CASE system and the corresponding dynamic model in the ARENA simulation system allows for a detailed analysis of the business process and obtain a set of indicators for analyzing its effectiveness. The developed simulation models of business processes for assessing their effectiveness are presented in the next chapter.

Impact Factor:

| | | |
|--------------------------|------------------------|----------------------|
| ISRA (India) = 4.971 | SIS (USA) = 0.912 | ICV (Poland) = 6.630 |
| ISI (Dubai, UAE) = 0.829 | ПИИЦ (Russia) = 0.126 | PIF (India) = 1.940 |
| GIF (Australia) = 0.564 | ESJI (KZ) = 8.997 | IBI (India) = 4.260 |
| JIF = 1.500 | SJIF (Morocco) = 5.667 | OAJI (USA) = 0.350 |

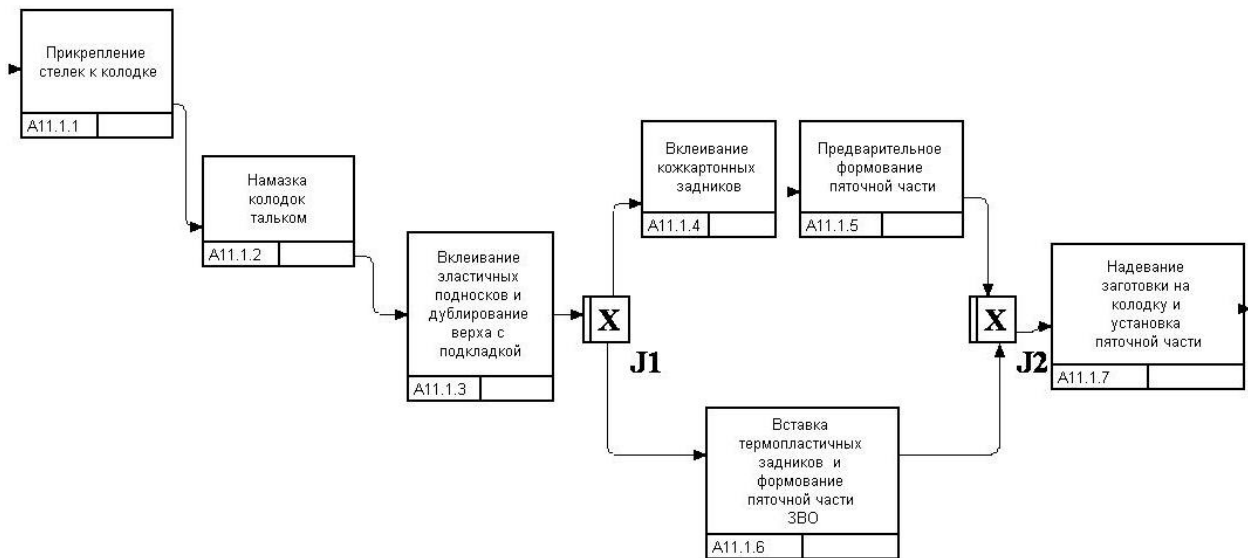

Figure: 1 - IDEF3 diagram of the block "Preparatory operations prior to forming"

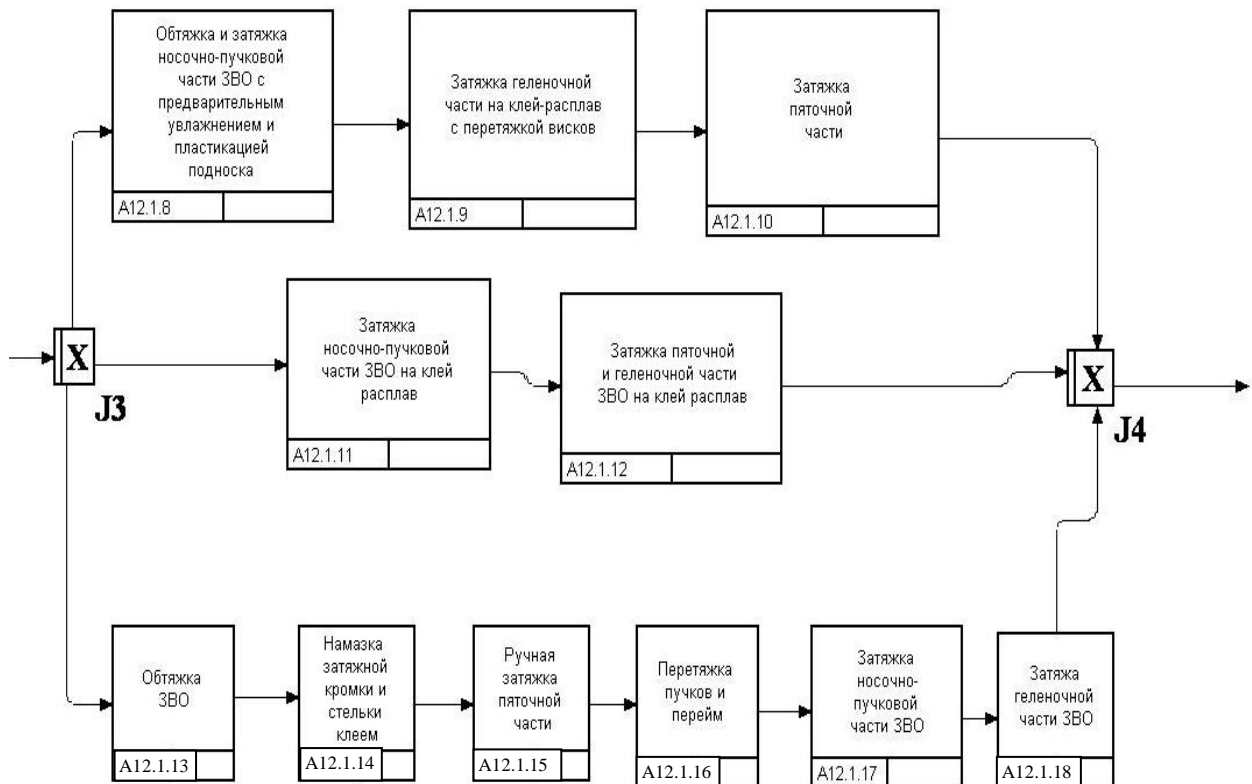

Figure: 2 - IDEF3-diagram of the block "Forming the shoe upper on the last"

Impact Factor:

| | | |
|--------------------------|------------------------|----------------------|
| ISRA (India) = 4.971 | SIS (USA) = 0.912 | ICV (Poland) = 6.630 |
| ISI (Dubai, UAE) = 0.829 | ПИИЦ (Russia) = 0.126 | PIF (India) = 1.940 |
| GIF (Australia) = 0.564 | ESJI (KZ) = 8.997 | IBI (India) = 4.260 |
| JIF = 1.500 | SJIF (Morocco) = 5.667 | OAJI (USA) = 0.350 |

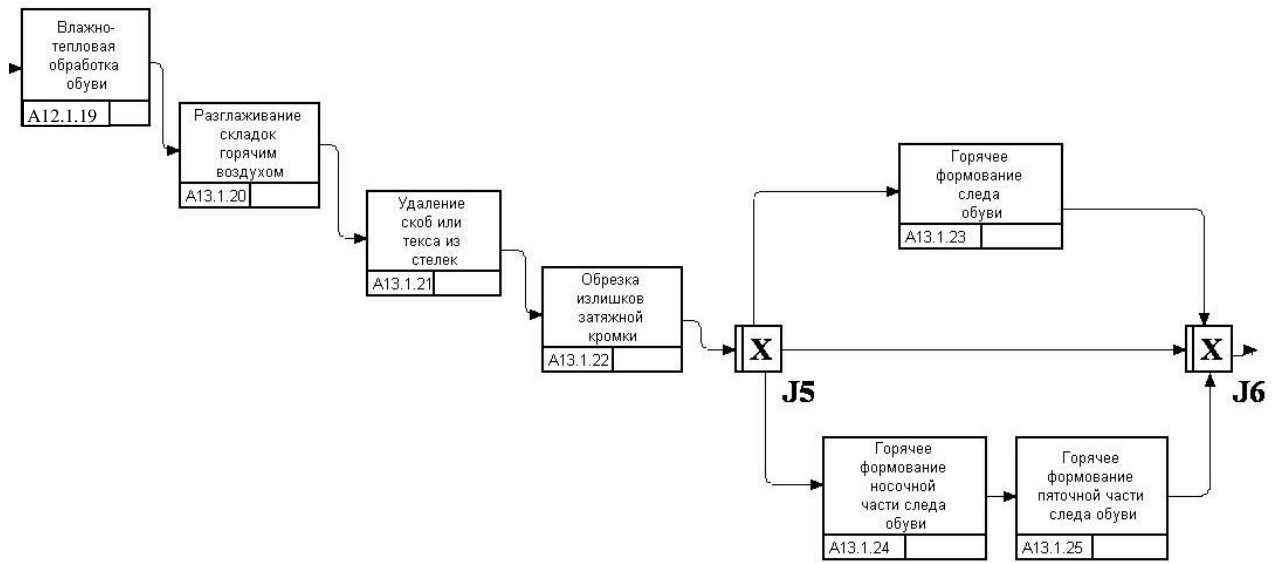

Figure: 3 - IDEF3 diagram of the block "Processing of a tightened shoe upper blank"

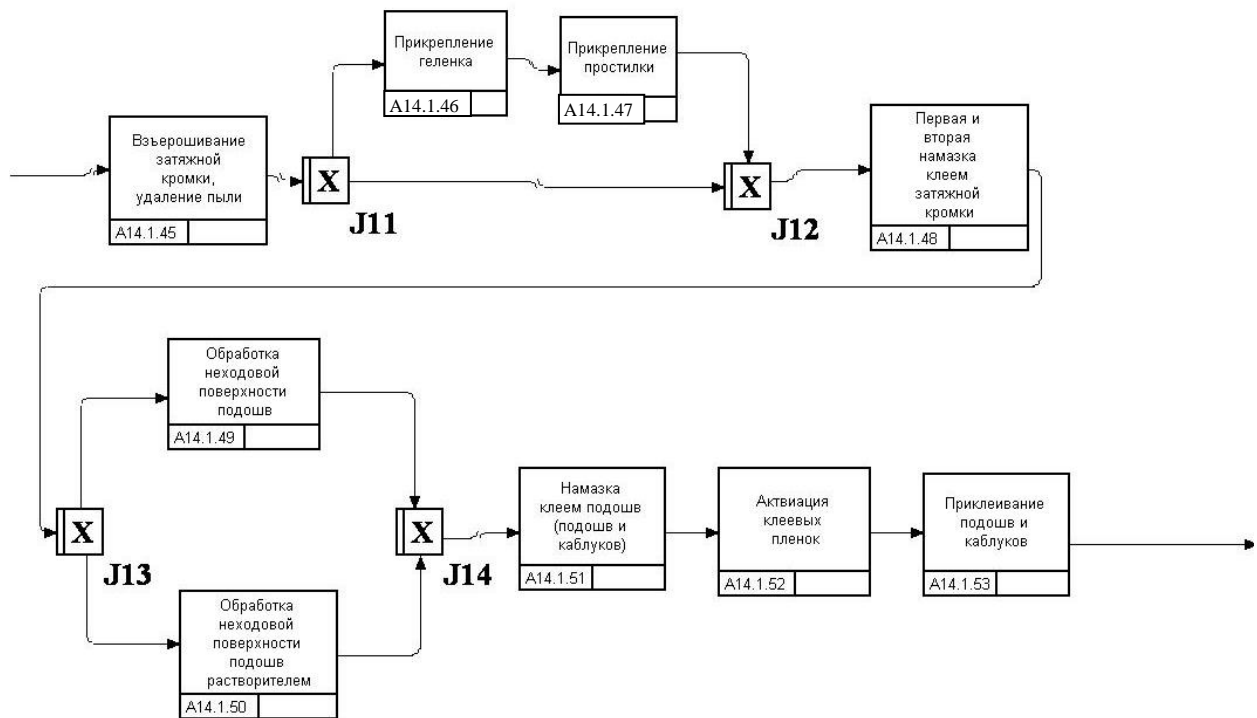

Figure: 4- IDEF3-diagram of the block "Preparing the track and attaching the details of the bottom of the shoe"

Impact Factor:

| | | |
|--------------------------|------------------------|----------------------|
| ISRA (India) = 4.971 | SIS (USA) = 0.912 | ICV (Poland) = 6.630 |
| ISI (Dubai, UAE) = 0.829 | ПИИЦ (Russia) = 0.126 | PIF (India) = 1.940 |
| GIF (Australia) = 0.564 | ESJI (KZ) = 8.997 | IBI (India) = 4.260 |
| JIF = 1.500 | SJIF (Morocco) = 5.667 | OAJI (USA) = 0.350 |

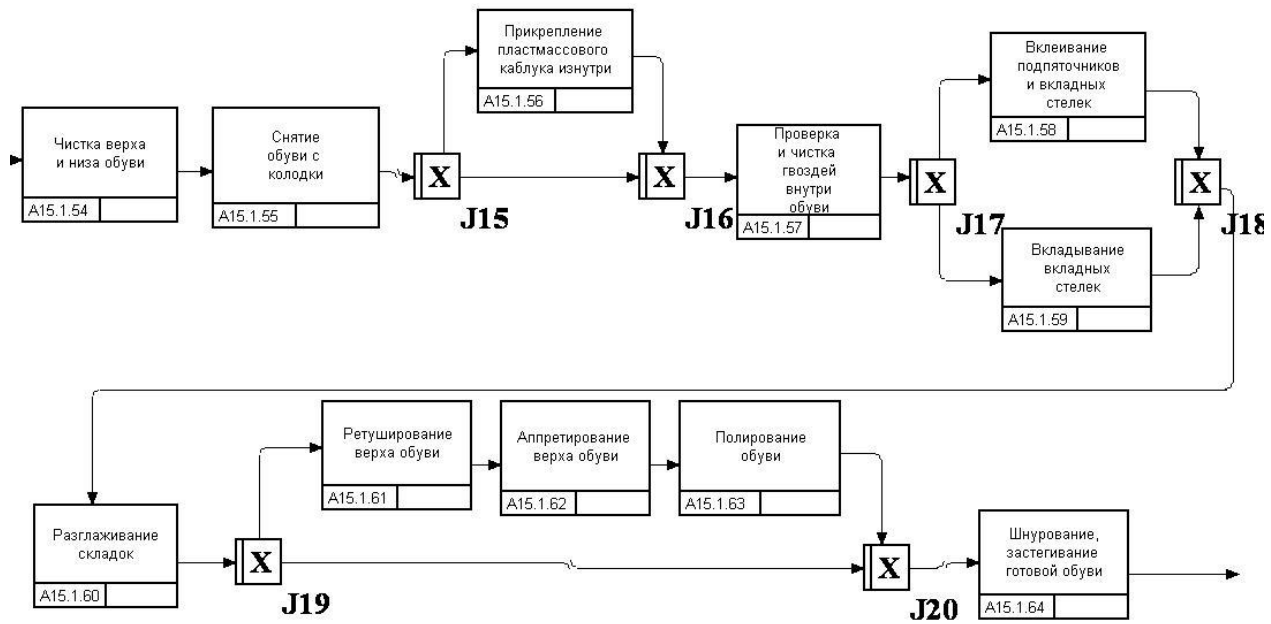

Figure: 5- IDEF3 diagram of the "Shoe finishing" block

Table 1 - Report on the IDEF3 diagram of the "Preparatory operations preceding molding "

| | |
|---------------|--|
| ActivityName: | Preparatory operations prior to forming |
| ActivityName: | Attaching the insoles to the last |
| Facts: | The operation is performed with three to five brackets or nails at the locations of the plugs. In open shoes, the insoles are pre-fitted |
| Objects: | Insole, block, staple wire 1.07□0.63 mm or machine tightening nail No. 12-15 |
| Description: | Equipment: PPS-S, PDN-1-O, 04054 / R1 |
| ActivityName: | Spreading talcum powder |
| Facts: | Pads are coated with talcum powder in the toe and heel |
| Objects: | Block, brush or sponge, grease, paraffin, talc |
| Description: | It is allowed to dust the pads with talcum immediately before covering the top blanks |
| ActivityName: | Bonding elastic toecaps and overlapping top with lining |
| Facts: | Elastic toe caps are coated with glue on both sides, and for unlined shoes - on the side of the mastic application. The sock is inserted between the top and the lining at a distance of 3-4 mm from the edge of the tightening edge |
| Objects: | ZVO, elastic toe cap |
| Description: | equipment: A2000, S1100V |
| ActivityName: | Bonding leather-cardboard backs |
| Facts: | Gluing of leather and molded leather-cardboard backdrops is done with latex, casein, dextrin, CMC and PVA adhesives |
| Objects: | Leather-cardboard back, ZVO |
| Description: | table ST-VZ |
| ActivityName: | Inserting thermoplastic heels and molding the heel of the ZVO |
| Facts: | Thermoplastic backdrops are heated immediately before gluing and molding the heel of the ZVO. Forming of the heel part with inserted thermoplastic backing is carried out at a punch temperature of 100-120 degrees, forming plates of 80 degrees, a punch pressure of 300-400 kPa for 15-30 s |
| Objects: | Thermoplastic backing, ZVO, punch |
| Description: | Equipment: G504 CF, G30 / 4G |
| ActivityName: | Pre-molding of the heel |
| Facts: | Punch temperature no more than 80-90 degrees |
| Objects: | ZVO with inserted leather-cardboard back, punch |
| Description: | Equipment: ZFP-1-O, 02231 / R12, 02201 / P2 |

Impact Factor:

| | | |
|--------------------------|------------------------|----------------------|
| ISRA (India) = 4.971 | SIS (USA) = 0.912 | ICV (Poland) = 6.630 |
| ISI (Dubai, UAE) = 0.829 | ПИИИ (Russia) = 0.126 | PIF (India) = 1.940 |
| GIF (Australia) = 0.564 | ESJI (KZ) = 8.997 | IBI (India) = 4.260 |
| JIF = 1.500 | SJIF (Morocco) = 5.667 | OAJI (USA) = 0.350 |

| | |
|---------------|--|
| ActivityName: | Putting the workpiece on the last and installing the heel |
| Facts: | For centering the workpiece on the last |
| Objects: | ZVO, last with attached insole |
| Description: | Equipment: PDN-1-0; 02015 / P5 or manually on a support stand using tightening pliers and a hammer |

The choice of shoe manufacturing technologies according to the criterion of the greatest efficiency.

The development of the best option for the technological process involves the solution of technical, economic and organizational problems in specific production conditions. At the same time, the selected technological process must ensure that all requirements for the quality of the product are met, its manufacture in the specified quantity and within the specified time frame. The development of such a technological process is a complex task and requires a systematic approach. The solutions to the problems of optimization of complex technological and technical systems are characterized by significant specificity due to the applied orientation of the solutions obtained; lack of information about the mechanisms occurring in the system of phenomena or processes; a significant number of optimality criteria and factors that are involved in optimization and modeling.

The procedure for choosing the best technology is a multicriteria problem, the solution of which is based on the desire as the best to choose the admissible vector, which is located closest to all other admissible vectors to some "ideal" (not admissible) vector or a set of "ideal" vectors.

An important step in solving this problem is the choice of such a technological process, the implementation of which, at given prices for the range of shoes and production volumes, will allow the company to get the maximum profit.

The existing choice of a technological process is carried out by an expert according to several, from his point of view, main parameters, for example, labor intensity, productivity, reduced costs, the level of individual production costs, equipment cost, etc. However, the existing list of indicators includes both quantitative and qualitative indicators. The efficiency of the selected variant of the technological process should be assessed not by one, but by several criteria. The transition to the mathematical formulation of the problem of choosing the best option and, therefore, to

the only optimality criterion is performed using the target programming method.

In general, any technology has different characteristics. Let there be a set of criteria f_1, f_2, \dots, f_m , each of which is desirable to maximize on the set of possible solutions X . In accordance with the target programming methodology, we assume that a non-empty set U is given in the criterion space R_m , which is called the set of ideal vectors. Moreover, it is considered that this set is unattainable, i.e. the equality $U \cap Y = \emptyset$, where Y means the set of possible vectors, i.e. $Y = f(X)$.

In addition, a metric is specified on the criterion space R_m , i.e. such a numeric function $\rho = \rho(y, z)$, which assigns to each pair of vectors y and z of the criterion space a certain non-negative number, called the distance between the vectors y and z .

In accordance with the target programming method, the chosen (best, optimal or most satisfactory) solution is declared $x^* \in X$ for which the equality holds:

$$\inf_{y \in U} \rho(f(x^*), y) = \min_{x \in X} \inf_{y \in U} \rho(f(x), y) \quad (1)$$

meaning that the vector $f(x^*)$ corresponding to the best solution x^* should be located from the set of ideal vectors at the minimum possible distance.

In this case, the choice of the metric is carried out from the parametric family:

$$\rho_a^{(s)}(y, z) = \left(\sum_{i=1}^m a_i |y_i - z_i|^s \right)^{\frac{1}{s}} \quad (2)$$

where $s \geq 1$ and $a = (a_1, \dots, a_m)$; $a_i > 0$ for all $i = 1, 2, \dots, m$.

By varying the vector of parameters a , the "unequal value" of the criteria is taken into account, giving greater importance to the component of the vector of parameters that meets the criterion of greater "value".

When comparing technologies according to three unequal criteria, the metric takes the form:

$$\rho^{(3)}(y, z) = \left(a_1 \cdot |y_1 - z_1|^3 + a_2 \cdot |y_2 - z_2|^3 + a_3 \cdot |y_3 - z_3|^3 \right)^{\frac{1}{3}} \dots \quad (3)$$

For four criteria:

$$\rho^{(4)}(y, z) = \left(a_1 \cdot |y_1 - z_1|^4 + a_2 \cdot |y_2 - z_2|^4 + a_3 \cdot |y_3 - z_3|^4 + a_4 \cdot |y_4 - z_4|^4 \right)^{\frac{1}{4}} \dots \quad (4)$$

In a particular case, when technologies are compared by two parameters $s = 2$ and $a_i = 1$, $i = 1, 2, \dots, m$, i.e. the criteria are equivalent, the Euclidean metric is obtained:

$$\rho^{(2)}(y, z) = \sqrt{(y_1 - z_1)^2 + (y_2 - z_2)^2} \dots \quad (5)$$

Information about the relative importance of the criteria is appropriate θ_{ij} identify at the beginning and

Impact Factor:

ISRA (India) = 4.971
 ISI (Dubai, UAE) = 0.829
 GIF (Australia) = 0.564
 JIF = 1.500

SIS (USA) = 0.912
 PIHII (Russia) = 0.126
 ESJI (KZ) = 8.997
 SJIF (Morocco) = 5.667

ICV (Poland) = 6.630
 PIF (India) = 1.940
 IBI (India) = 4.260
 OAJI (USA) = 0.350

compare the technologies taking into account the importance factors of the criteria. The theory of the relative importance of criteria is based on the following definition, which implements the idea of compensation, in which low indicators according to one criterion (or according to several criteria at once) are compensated by a high indicator according to another criterion (or simultaneously according to some other criteria). Let i and j be two different criterion numbers. The i -th criterion f_i is more important than the j -th criterion with given positive parameters w_i and w_j , if for any vector $y = (y_1, y_2, \dots, y_n) \in R_m$ the relation holds $y' \succ y$ where $y' = (y_1, y_2, \dots, y_n)$, and:

$y'_i = y_i + w_i$; $y'_j = y_j + w_j$; $y'_s = y_s$, for all $s = 1, 2, \dots, m, s \neq i, s \neq j$.

The numbers w_i and w_j are used to quantify the degree of relative importance; for these purposes, the ratio $\frac{w_i}{w_j}$, which varies from zero to infinity.

Let the i -th criterion be more important than the j -th criterion with positive parameters w_i and w_j . Positive number $\theta_{ij} = \frac{w_j}{w_i + w_j}$ is called the coefficient of relative importance for the specified pair of criteria.

As $\theta_{ij} = \frac{1}{\frac{w_i}{w_j} + 1}$ and attitude $\frac{w_i}{w_j}$ is in the range

from zero to infinity, then the coefficient of relative importance always satisfies the inequality (normalization condition): $0 < \theta_{ij} < 1$. It shows the share of the loss by the least important criterion in comparison with the sum of the indicated loss and the increase by the more important criterion. If the coefficient θ_{ij} is close to unity, this means that with a relatively small increase according to the more important i -th criterion, large losses appear according to the less important j -th criterion.

When $\theta_{ij} \rightarrow 0$ losses according to a less important criterion are insignificant, their appearance is due to the receipt of a significant increase according to a more important criterion, i.e. the degree of importance of the i -th criterion is relatively low. This position is reflected in the low value of the coefficient of relative importance. If $\theta_{ij} = 0.5$, then the value of the loss according to the less important criterion is equal to the value of the increase according to the more important criterion. This technique greatly simplifies the procedure for finding the best solution.

Distance is taken as a metric $\rho_a^{(s)}(y, z)$, $s \geq 1$, with a vector $a = (1, 1, \dots, 1)$ having the same components, since the relative importance of the criteria θ_{ij} taken into account earlier at the stage of using information about the importance of the criteria, and the origin of coordinates $0 = (0, 0)$ is taken as the ideal vector.

As a result, formula (2) will take the form:
 - for two criteria:

$$\rho^{(2)}(y^{(i)}, 0) = \sqrt{\bar{y}_1^2 + \bar{y}_2^2}; \quad (6)$$

- for three criteria:

$$\rho^{(3)}(y^{(i)}, 0) = \sqrt[3]{\bar{y}_1^3 + \bar{y}_2^3 + \bar{y}_3^3}; \quad (7)$$

- for four criteria:

$$\rho^{(4)}(y^{(i)}, 0) = \sqrt[4]{\bar{y}_1^4 + \bar{y}_2^4 + \bar{y}_3^4 + \bar{y}_4^4}, \quad (8)$$

Where \bar{y}_i - modified values of criteria.

However, it should be pointed out that the information situation that arises when solving the problem of choosing the best option for a technological process differs from the information situation that takes place in mathematical statistics in the variety and form of assigning the initial information. In this situation, it is necessary to take into account the multidimensionality of the space of indicators of the processes under study with objectively existing uncertainty in assessing the impact of each specific indicator on the efficiency of the process as a whole.

Thus, the considered approach allows, taking into account the production program, to compare the promising options for combining technologies and equipment, to choose the most effective one and, on this basis, to form a flexible technological process to ensure the operation of multi-assortment flows.

For the implementation of the task, software has been developed, with the help of which the effectiveness of the technological process is assessed, thereby making it possible to improve the quality of organizational and technological solutions and stabilize the level of competitiveness of the footwear produced.

Simulation modeling and parameter calculation technological processes

The functional modeling method allows you to examine existing business processes, identify their shortcomings and build an ideal model for the enterprise. However, the problem often arises of optimizing specific technological processes, studying the influence of various parameters on a particular technological process. In this case, the functional model may not be enough. To optimize technological processes, it is advisable to use the method of simulation.

Simulation allows you to build and "play" models. As a result of "playing", you can get statistics of the ongoing processes as it would be in reality. Typically, simulation models are built to find the optimal solution under resource constraints when other mathematical models are too complex.

Tables for calculating and combining the number of workers are used as the initial data for simulating the flow of shoe assembly.

Impact Factor:

ISRA (India) = 4.971
 ISI (Dubai, UAE) = 0.829
 GIF (Australia) = 0.564
 JIF = 1.500

SIS (USA) = 0.912
 PIHII (Russia) = 0.126
 ESJI (KZ) = 8.997
 SJIF (Morocco) = 5.667

ICV (Poland) = 6.630
 PIF (India) = 1.940
 IBI (India) = 4.260
 OAJI (USA) = 0.350

The Arena simulation model includes the following basic elements: sources and sinks (Create and Dispose), processes (Process) and queues (Queue). Sources are elements from which information or objects enter the model. The rate at which data or objects arrive from a source is usually given by a statistical function. A sink is a device for receiving information or objects. The concept of a queue is close to that of a data warehouse - it is a place where objects await processing. The processing time of objects (performance) in different processes can be different. As a result, some processes can accumulate objects waiting for their turn. The type of queue in the simulation model can be specified. A queue can be similar to a stack - the objects that came last in the queue are the first to be sent for further processing (LIFO: last-in-first-out). An alternative to the stack can be sequential processing, when the first objects that come first are sent for further processing (FIFO: first-in-first-out). Processes are analogous to work in a functional model. In the simulation model, the performance of the processes can be specified.

Arena has a set of tools for building models, which include a tool palette, a set of guides, etc. The Arena tool palette appears (Fig. 4.62), which contains two types of Flowchart and Data modules.

Modules of the Flowchart type (including Create, Dispose and Process) are used to display flows of

objects and can be transferred to the workspace of the drag & drop model. Modules of type Data (for example, Queue) cannot be placed in the workspace of the model and are used to set the parameters of the model. The parameter editing window appears at the bottom of the model when the focus is on a module of type Data.

To set properties, a module of the Flowchart type must be double-clicked on it and set the parameter values in the dialog that appears. To set the properties of the Resource module (of the Data type), click on it once on the toolbar and enter the parameter values in the lower window. To play the model, go to the Run / Go menu. The simulation models based on the above initial data are shown in Figures 6 - 17.

The presence of an instrumental environment for the simulation of production systems allows organizing an experiment on a model of the projected system with various input parameters, monitoring the process of the system's functioning with the subsequent assessment of the simulation results. Conducting a series of experiments allows you to improve the quality of management decisions and predict their consequences.

Combined use of the BPwin CASE-tool for building a functional model and the Arena simulation system allows you to most effectively optimize the technological processes of manufacturing leather goods.

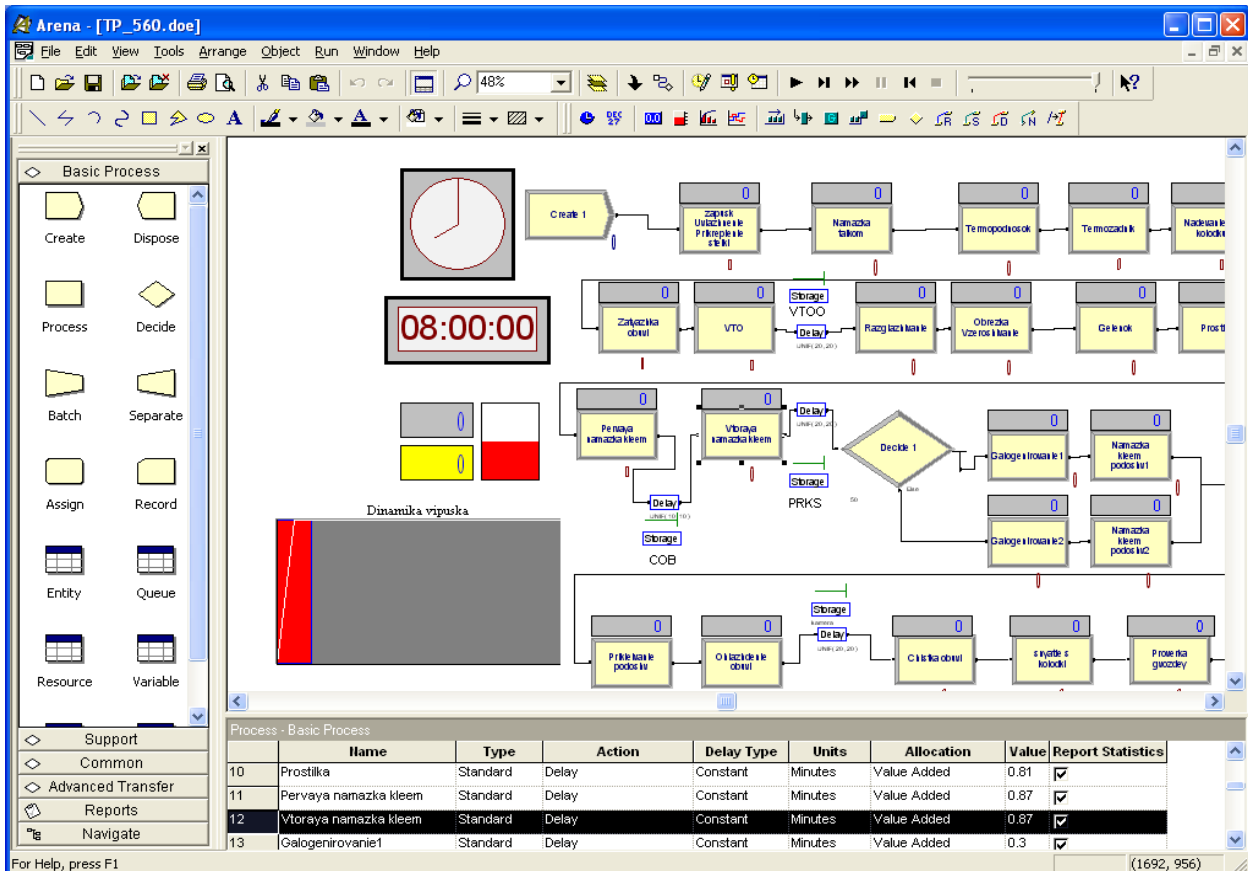
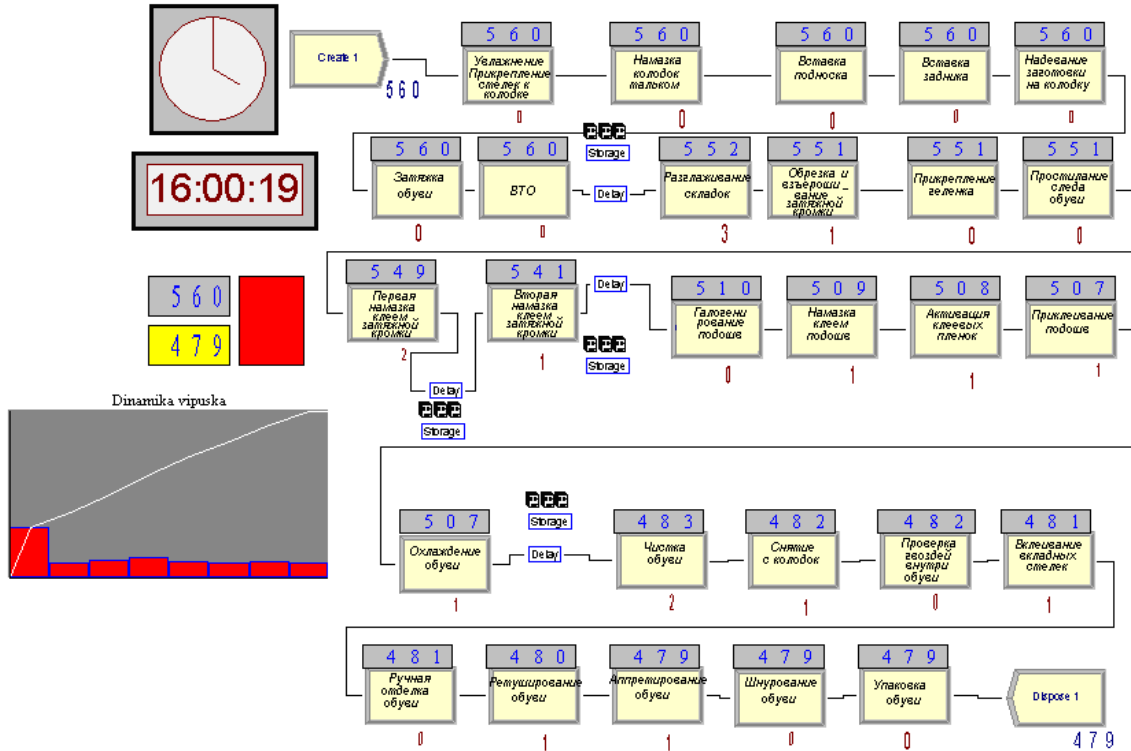

Figure: 6- General view of the program window and tool palette

Impact Factor:

| | | |
|--------------------------|------------------------|----------------------|
| ISRA (India) = 4.971 | SIS (USA) = 0.912 | ICV (Poland) = 6.630 |
| ISI (Dubai, UAE) = 0.829 | ПИИЦ (Russia) = 0.126 | PIF (India) = 1.940 |
| GIF (Australia) = 0.564 | ESJI (KZ) = 8.997 | IBI (India) = 4.260 |
| JIF = 1.500 | SJIF (Morocco) = 5.667 | OAJI (USA) = 0.350 |

Release per shift 560 pair
 Labor intensity 19.4 minutes
 Average time shoes are out of process (WTO, drying of adhesive films, cooling) 70 min
 The maximum number of shoes at the same time under processing 125 pair
 Unfinished production 81 pair
 Shift duration 480 minutes



**Figure 7. -Simulation model of the shoe assembly technological process (option No. 1).
 Release 560 pairs / shift**

Release per shift 560 pair
 Labor intensity 19.4 minutes
 Average time shoes are out of process (WTO, drying of adhesive films, cooling) 70 min
 The maximum number of shoes at the same time under processing 131 pairs
 Work in progress 70 pairs
 Shift duration 480 mi

Impact Factor:

| | | |
|--------------------------|------------------------|----------------------|
| ISRA (India) = 4.971 | SIS (USA) = 0.912 | ICV (Poland) = 6.630 |
| ISI (Dubai, UAE) = 0.829 | ПИИИ (Russia) = 0.126 | PIF (India) = 1.940 |
| GIF (Australia) = 0.564 | ESJI (KZ) = 8.997 | IBI (India) = 4.260 |
| JIF = 1.500 | SJIF (Morocco) = 5.667 | OAJI (USA) = 0.350 |

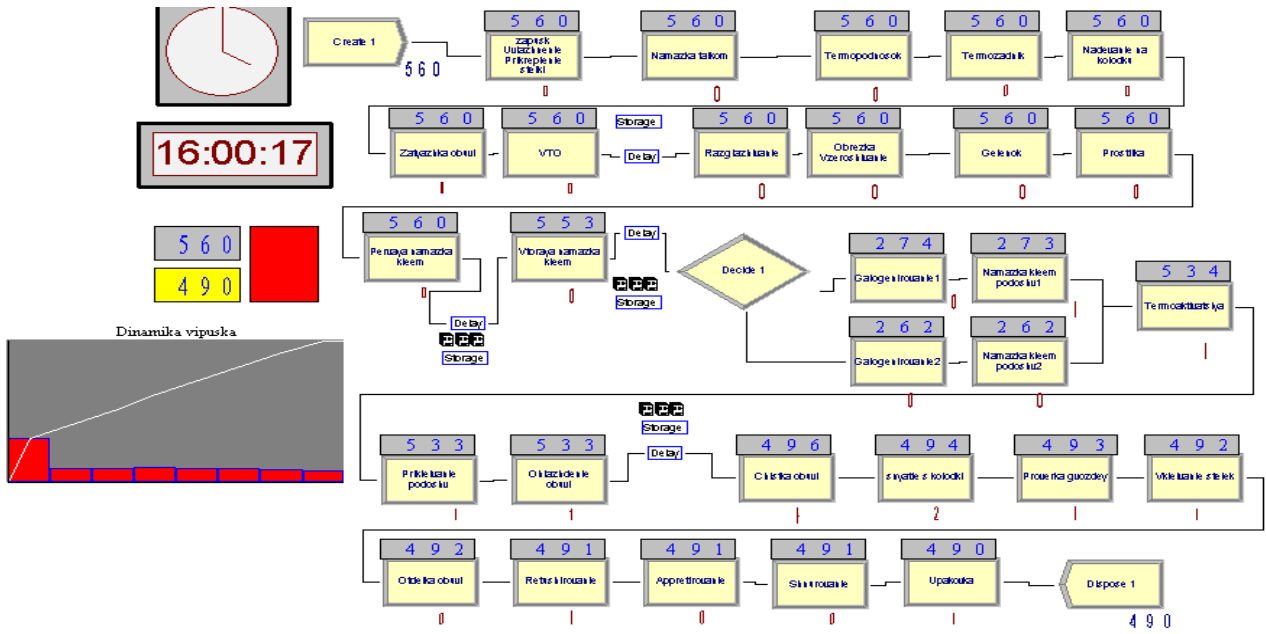
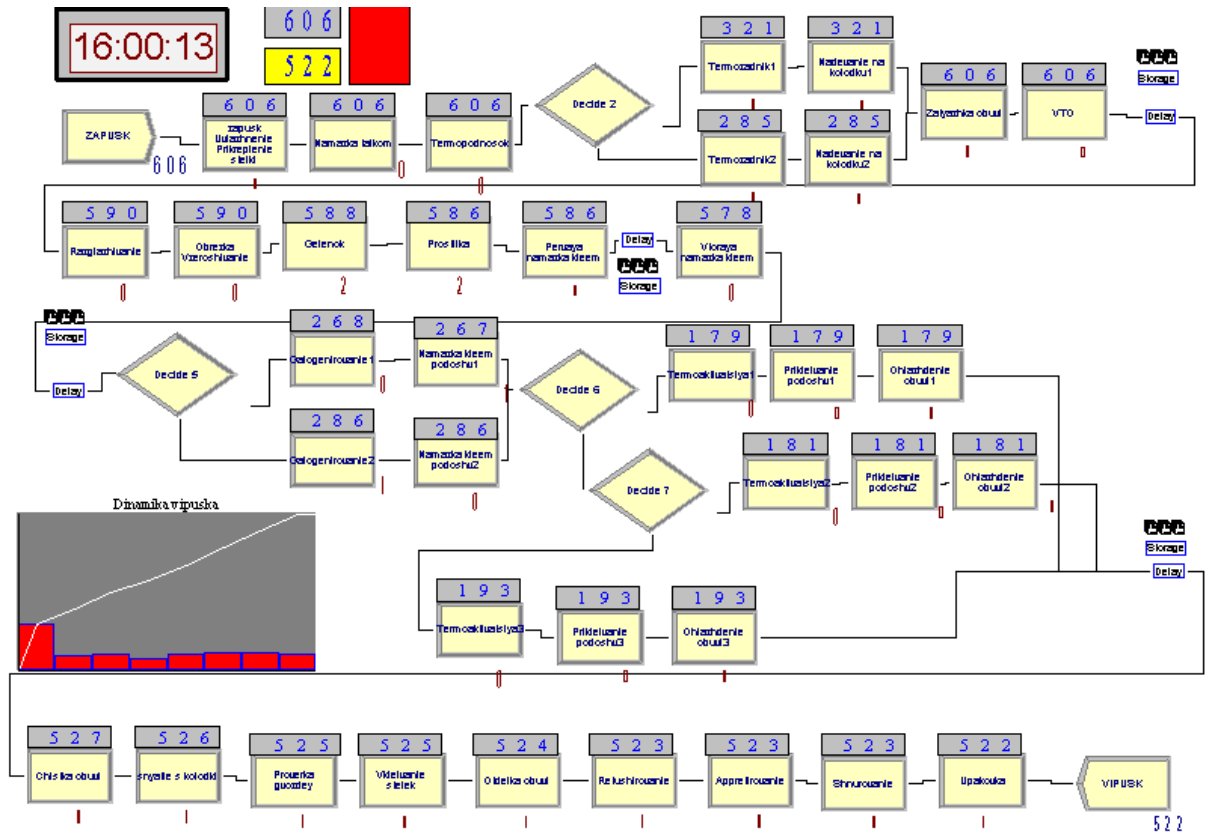

Figure: 8 - Simulation model of the technological process of shoe assembly (option No. 1) with additional equipment. Release 560 pairs / shift

- Release per shift 606 pair
- Labor intensity 19.4 minutes
- Average time spent on shoes outside the process (WTO, drying of adhesive films, cooling) 70 minutes
- The maximum number of shoes at the same time under processing 137 pair
- Work in progress 84 pairs
- Shift duration 480 min

Impact Factor:

| | | |
|--------------------------|------------------------|----------------------|
| ISRA (India) = 4.971 | SIS (USA) = 0.912 | ICV (Poland) = 6.630 |
| ISI (Dubai, UAE) = 0.829 | ПИИИ (Russia) = 0.126 | PIF (India) = 1.940 |
| GIF (Australia) = 0.564 | ESJI (KZ) = 8.997 | IBI (India) = 4.260 |
| JIF = 1.500 | SJIF (Morocco) = 5.667 | OAJI (USA) = 0.350 |

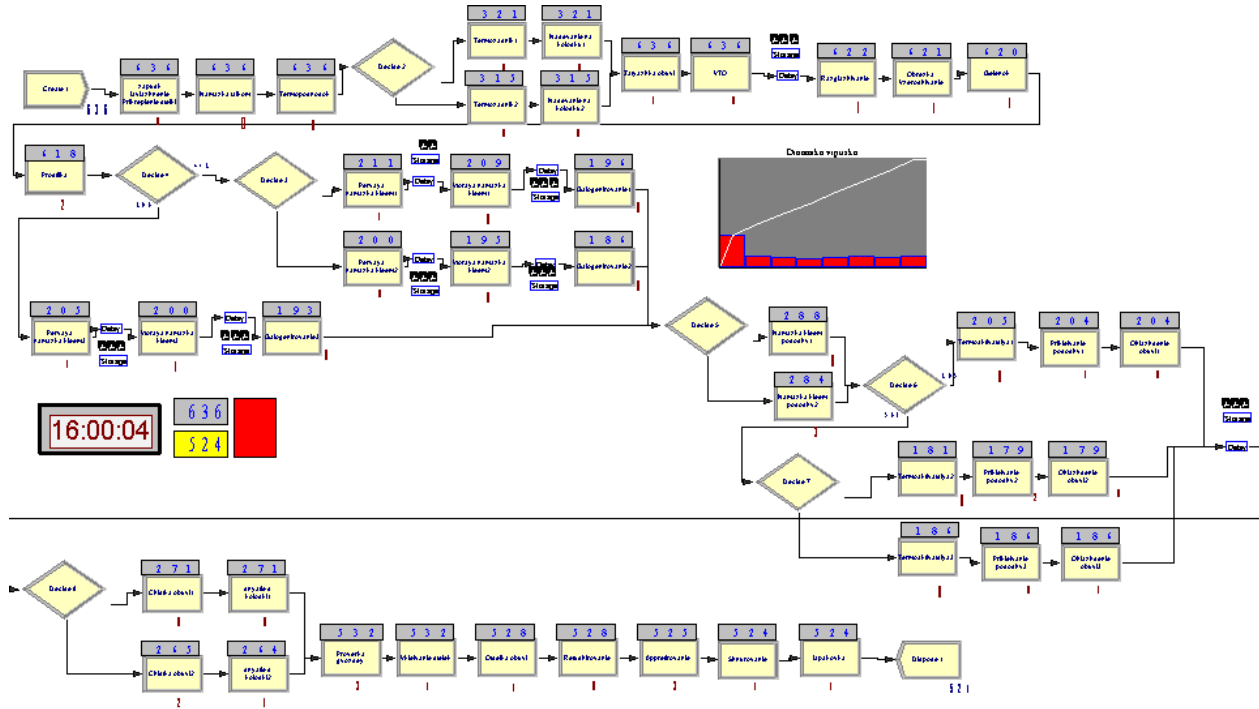

**Figure: 9 - Simulation model of the technological process of shoe assembly (option No. 1).
Release 606 pairs / shift**

- Release per shift 636 pair
- Labor intensity 19.4 minutes
- Average time shoes are out of process (WTO, drying of adhesive films, cooling) 70 min
- The maximum number of shoes at the same time under processing 143 pairs
- Unfinished production 112 pair
- Shift duration 480 minutes

Impact Factor:

| | | |
|--------------------------|------------------------|----------------------|
| ISRA (India) = 4.971 | SIS (USA) = 0.912 | ICV (Poland) = 6.630 |
| ISI (Dubai, UAE) = 0.829 | ПИИЦ (Russia) = 0.126 | PIF (India) = 1.940 |
| GIF (Australia) = 0.564 | ESJI (KZ) = 8.997 | IBI (India) = 4.260 |
| JIF = 1.500 | SJIF (Morocco) = 5.667 | OAJI (USA) = 0.350 |

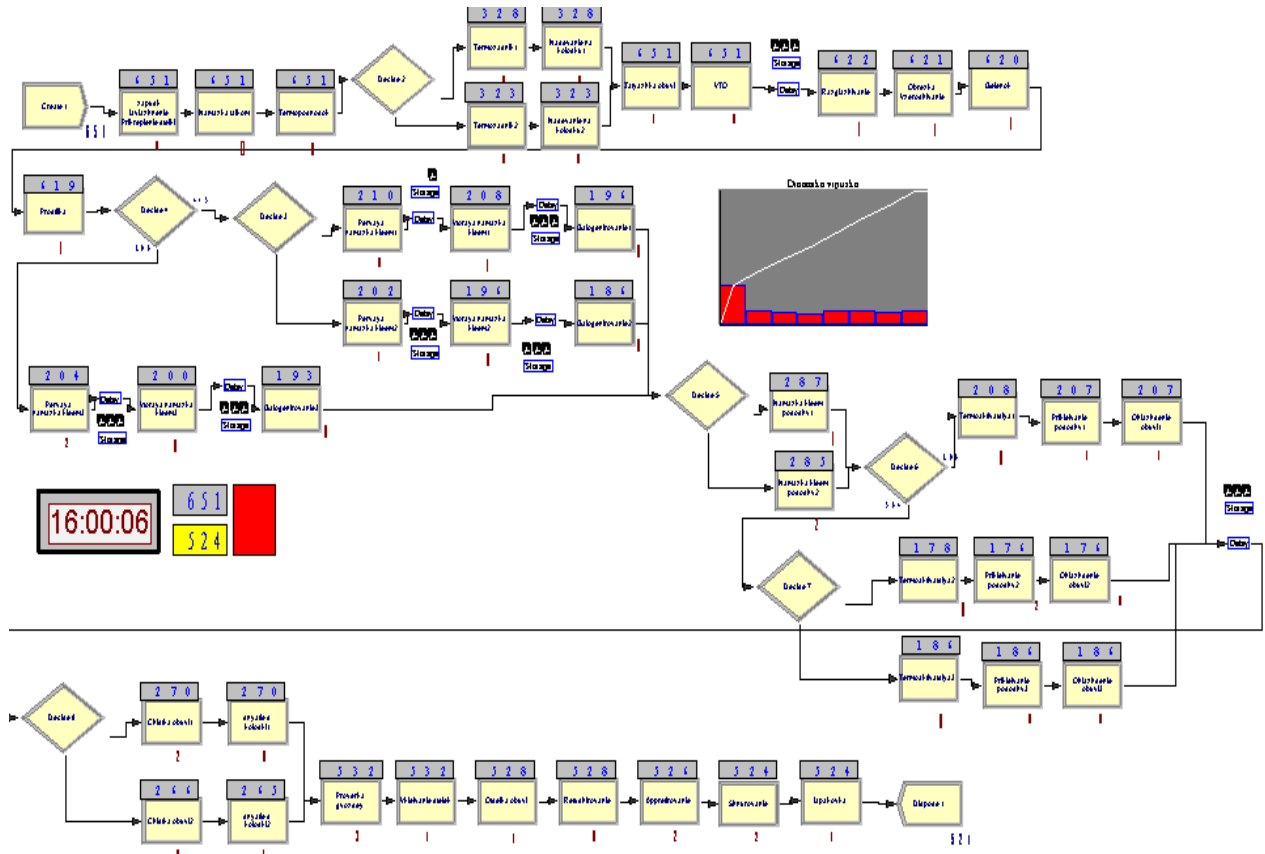

**Figure: 10 - Simulation model of the technological process of shoe assembly (option No. 1).
Release 636 pairs / shift**

Release per shift 651 pair
 Labor intensity 19.4 minutes
 Average time spent on shoes outside the process (WTO,
 drying of adhesive films, cooling) 70 min
 The maximum number of shoes
 simultaneously being processed 143 pairs
 Unfinished production 127 pair
 Shift duration 480 minutes

Impact Factor:

| | | |
|--------------------------|------------------------|----------------------|
| ISRA (India) = 4.971 | SIS (USA) = 0.912 | ICV (Poland) = 6.630 |
| ISI (Dubai, UAE) = 0.829 | ПИИИ (Russia) = 0.126 | PIF (India) = 1.940 |
| GIF (Australia) = 0.564 | ESJI (KZ) = 8.997 | IBI (India) = 4.260 |
| JIF = 1.500 | SJIF (Morocco) = 5.667 | OAJI (USA) = 0.350 |

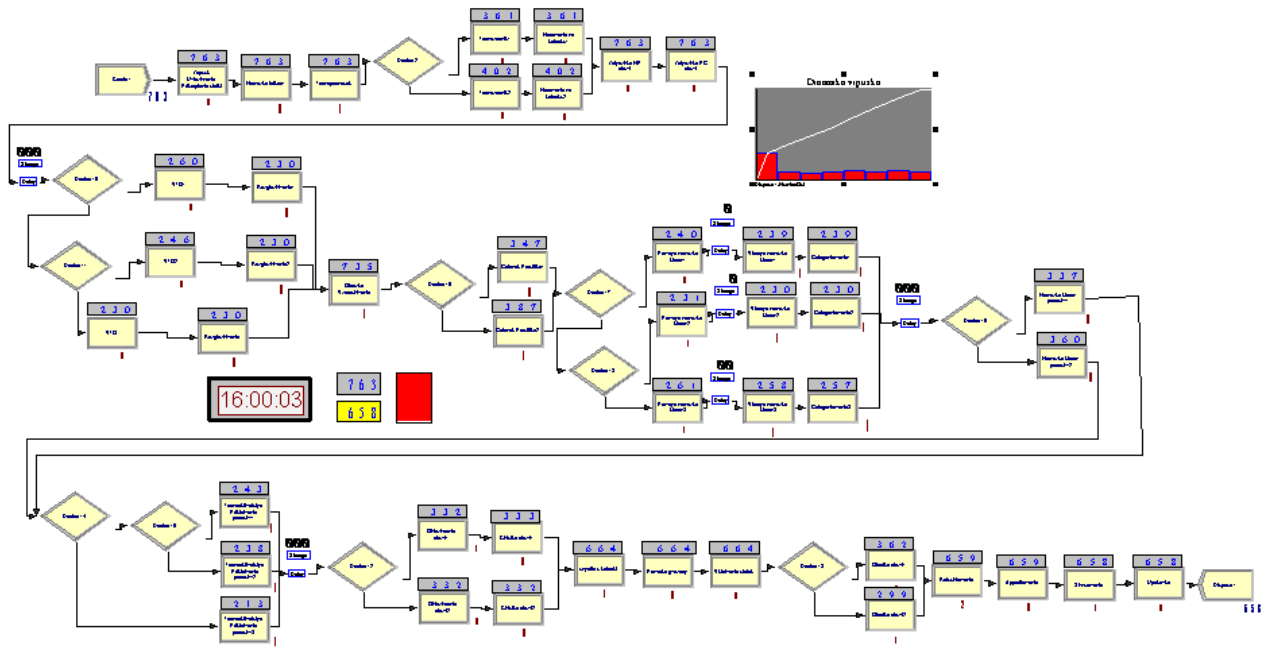

**Figure: 11 - Simulation model of the shoe assembly technological process (option No. 1).
Issue 651 pairs / shift**

Release in shift 763 pairs
 Labor intensity 19.4 minutes
 Average time shoes are out of process
 (WTO, drying of adhesive films, cooling) 55 minutes
 The maximum number of shoes at the same time
 processed 146 pairs
 Unfinished production 105 pair
 Shift duration 480 minutes

Impact Factor:

| | | |
|--------------------------|------------------------|----------------------|
| ISRA (India) = 4.971 | SIS (USA) = 0.912 | ICV (Poland) = 6.630 |
| ISI (Dubai, UAE) = 0.829 | ПИИИ (Russia) = 0.126 | PIF (India) = 1.940 |
| GIF (Australia) = 0.564 | ESJI (KZ) = 8.997 | IBI (India) = 4.260 |
| JIF = 1.500 | SJIF (Morocco) = 5.667 | OAJI (USA) = 0.350 |

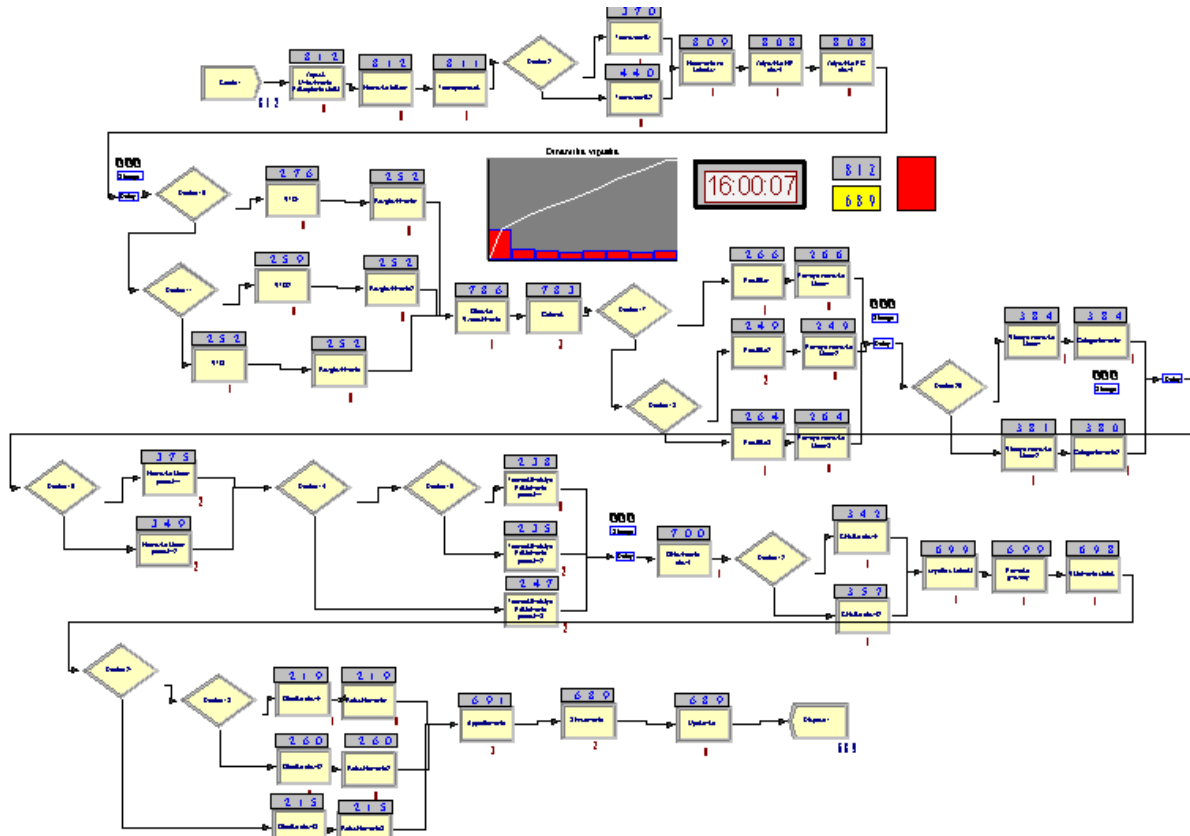

**Figure 12 Simulation model of the shoe assembly technological process (option No. 1).
Release of 763 pairs / shift**

- Release per shift 812 pair
- Labor intensity 19.4 minutes
- The average time spent on shoes outside the process (WTO, drying of adhesive films, cooling) .
- The maximum number of shoes at the same time
under processing 146 pairs
- Unfinished production 123 pairs
- Shift duration 480 minutes

Impact Factor:

| | | |
|--------------------------|------------------------|----------------------|
| ISRA (India) = 4.971 | SIS (USA) = 0.912 | ICV (Poland) = 6.630 |
| ISI (Dubai, UAE) = 0.829 | ПИИЦ (Russia) = 0.126 | PIF (India) = 1.940 |
| GIF (Australia) = 0.564 | ESJI (KZ) = 8.997 | IBI (India) = 4.260 |
| JIF = 1.500 | SJIF (Morocco) = 5.667 | OAJI (USA) = 0.350 |



**Figure: 13- Simulation model of the technological process of shoe assembly (option No. 1).
Release 812 pairs / shift**

- Release per shift 560 pair
- Labor intensity 20.51 minutes
- Average time shoes are out of process
(WTO, drying of adhesive films, cooling) 70 min
- The maximum number of shoes at the same time
under processing 120 pairs
- Work in progress 89 pairs
- Shift duration 480 min

Impact Factor:

| | | |
|--------------------------|------------------------|----------------------|
| ISRA (India) = 4.971 | SIS (USA) = 0.912 | ICV (Poland) = 6.630 |
| ISI (Dubai, UAE) = 0.829 | ПИИЦ (Russia) = 0.126 | PIF (India) = 1.940 |
| GIF (Australia) = 0.564 | ESJI (KZ) = 8.997 | IBI (India) = 4.260 |
| JIF = 1.500 | SJIF (Morocco) = 5.667 | OAJI (USA) = 0.350 |

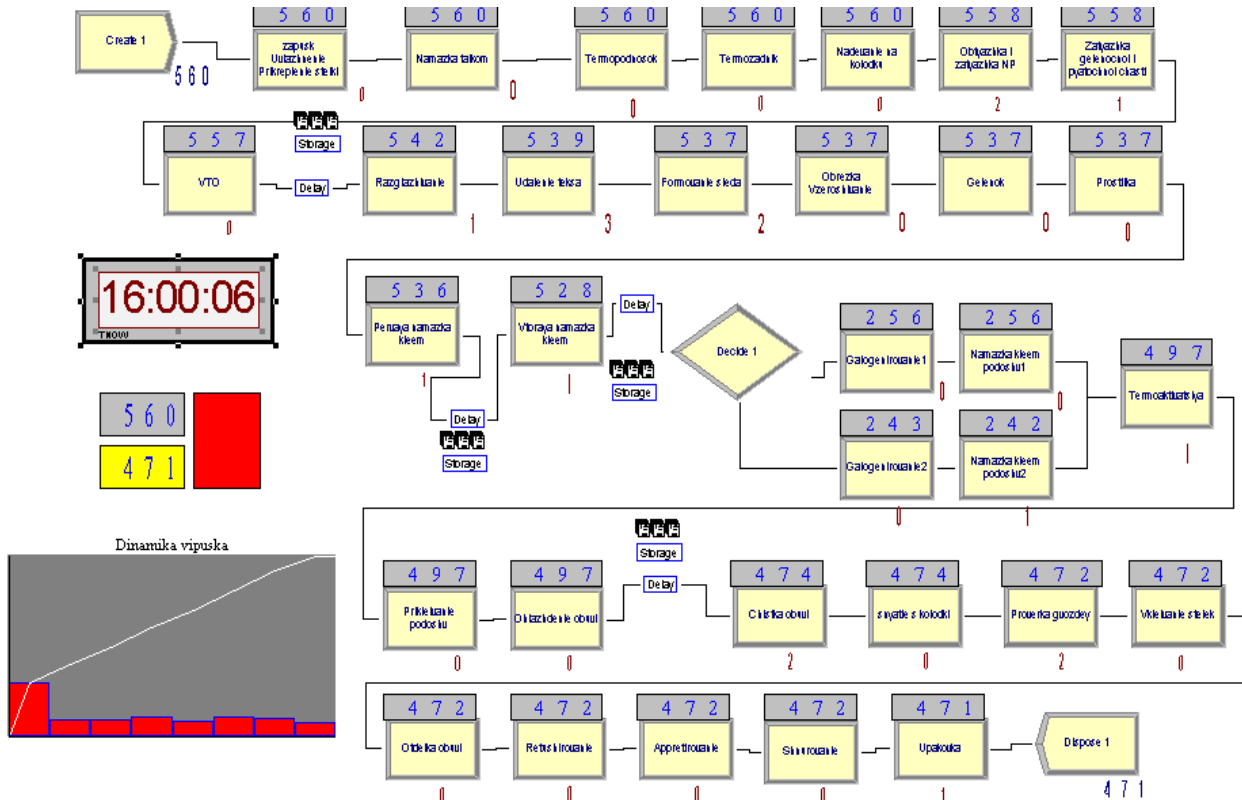

Figure: 14 - Simulation model of the technological process of shoe assembly (option number 2). Release 560 pairs / shift

Release per shift 606 pair
 Labor intensity 20.51 minutes
 Average time shoes are out of process
 (WTO, drying of adhesive films, cooling) 70 min

The maximum number of shoes
 simultaneously being processed 140 pair
 Unfinished production 109 pair
 Shift duration 480 minutes

Impact Factor:

| | | |
|--------------------------|------------------------|----------------------|
| ISRA (India) = 4.971 | SIS (USA) = 0.912 | ICV (Poland) = 6.630 |
| ISI (Dubai, UAE) = 0.829 | ПИИИ (Russia) = 0.126 | PIF (India) = 1.940 |
| GIF (Australia) = 0.564 | ESJI (KZ) = 8.997 | IBI (India) = 4.260 |
| JIF = 1.500 | SJIF (Morocco) = 5.667 | OAJI (USA) = 0.350 |

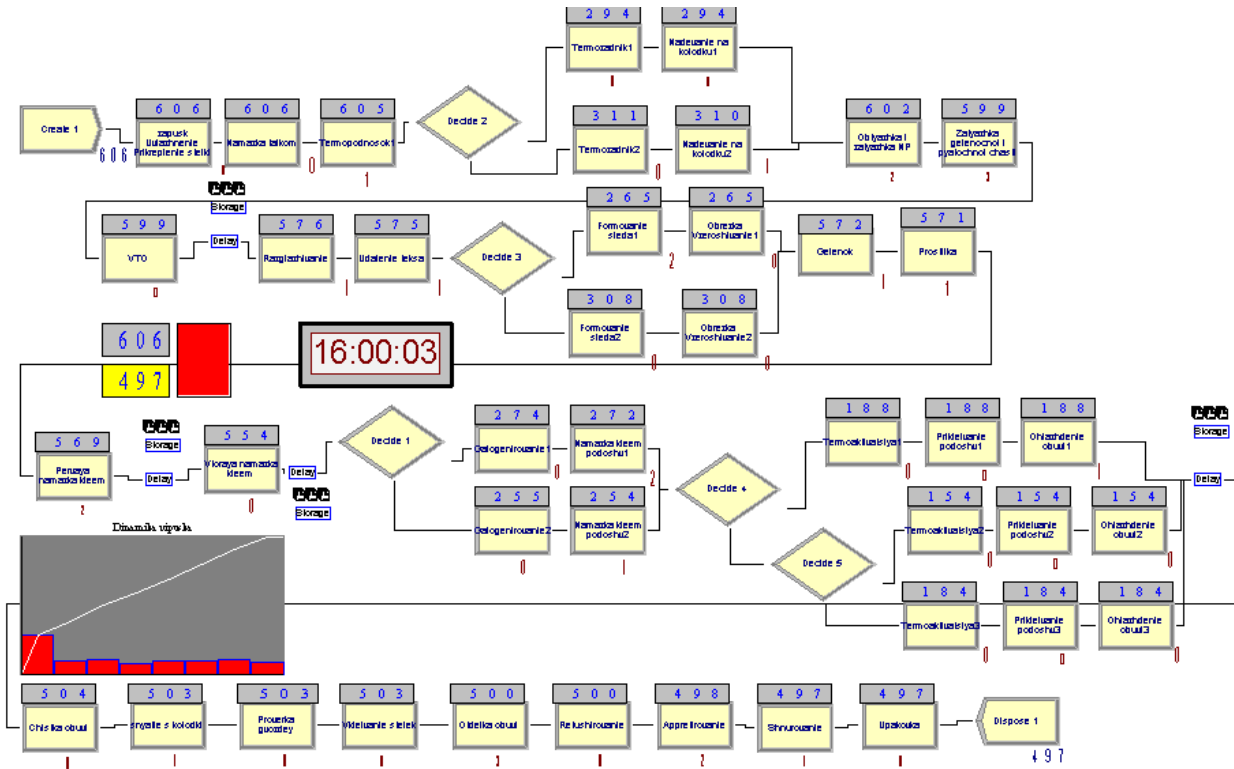

Figure: 15 - Simulation model of the technological process of shoe assembly (option number 2). Release 606 pairs / shift

Release per shift 651 pair
 Labor intensity 0.51 minutes
 Average time shoes are out of process
 (WTO, drying of adhesive films, cooling) 70 min

The maximum number of shoes
 simultaneously being processed 140 pair
 Unfinished production 112 pair
 Shift duration 480 minutes

Impact Factor:

| | | |
|--------------------------|------------------------|----------------------|
| ISRA (India) = 4.971 | SIS (USA) = 0.912 | ICV (Poland) = 6.630 |
| ISI (Dubai, UAE) = 0.829 | ПИИЦ (Russia) = 0.126 | PIF (India) = 1.940 |
| GIF (Australia) = 0.564 | ESJI (KZ) = 8.997 | IBI (India) = 4.260 |
| JIF = 1.500 | SJIF (Morocco) = 5.667 | OAJI (USA) = 0.350 |

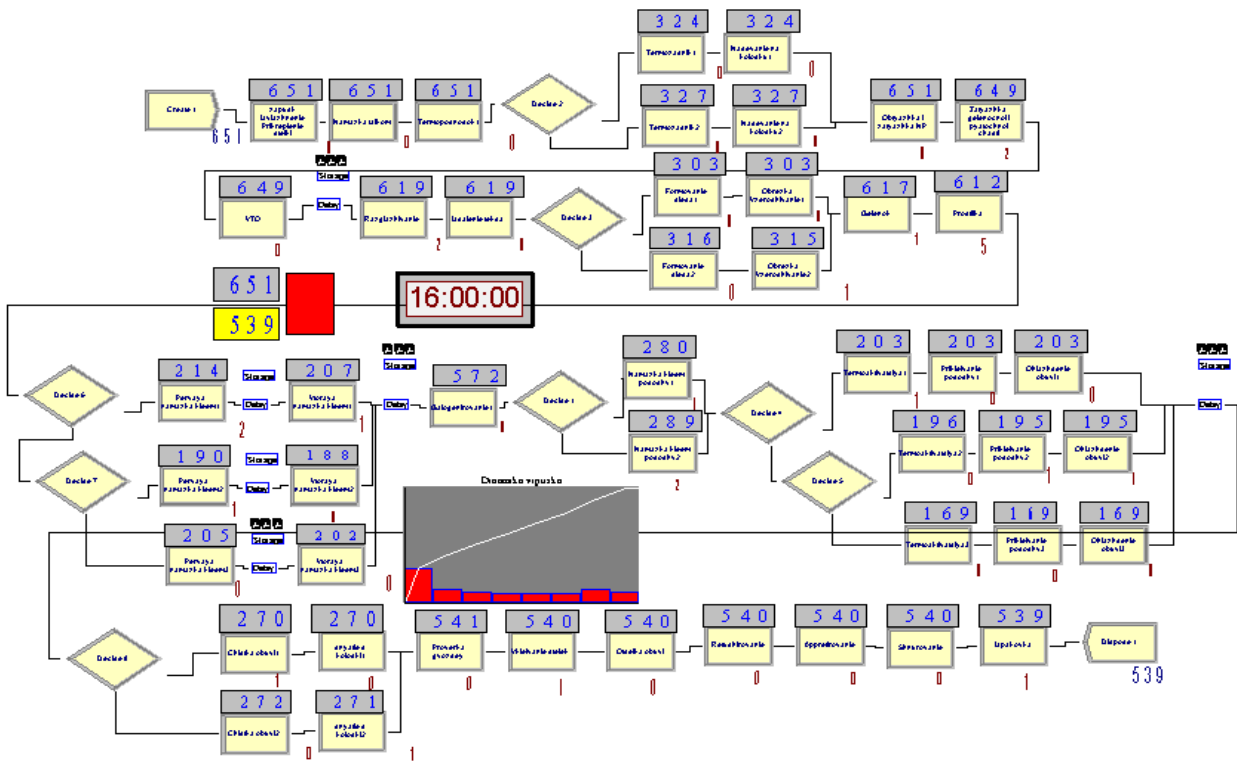

**Figure: 16 - Simulation model of the shoe assembly technological process (option No. 2).
Issue 651 pairs / shift**

Release per shift 548 pair
 Labor intensity 13.9 minutes
 Average time the shoes are outside the process (WTO, drying of adhesive films, cooling) 85 min
 The maximum number of shoes being processed at the same time 135 pair
 Work in progress 14 pairs
 production of 14 pairs The duration of the shift is 480 minutes.

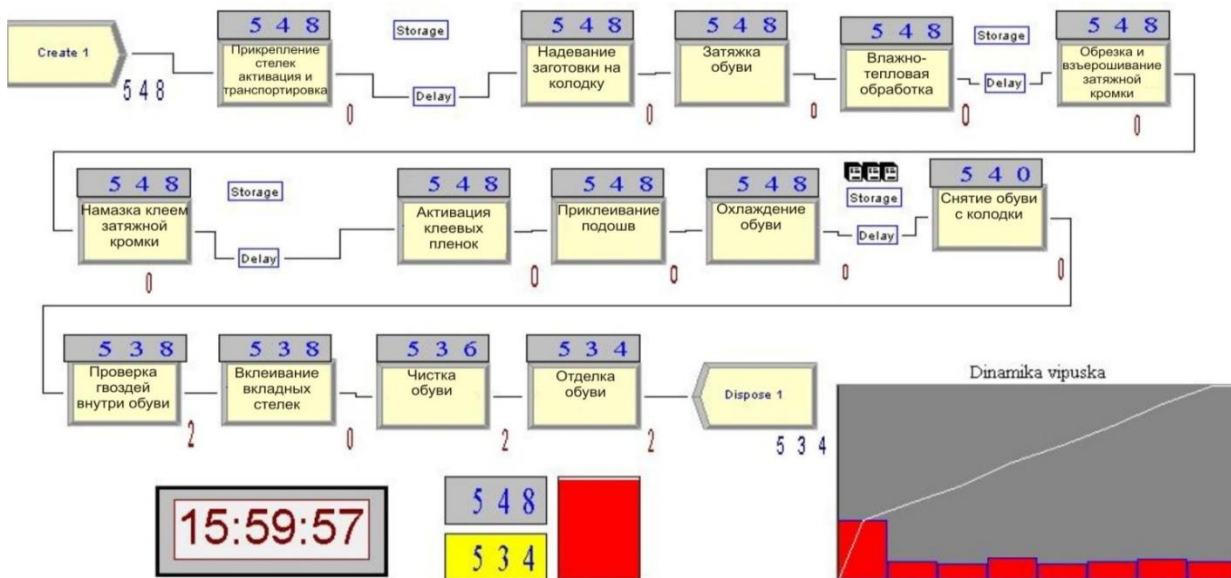

**Figure: 17 - Simulation model of the shoe assembly technological process (RINK-system).
Release 548 pairs / shift**

| | | | |
|-----------------------|--------------------------|------------------------|----------------------|
| Impact Factor: | ISRA (India) = 4.971 | SIS (USA) = 0.912 | ICV (Poland) = 6.630 |
| | ISI (Dubai, UAE) = 0.829 | ПИИЦ (Russia) = 0.126 | PIF (India) = 1.940 |
| | GIF (Australia) = 0.564 | ESJI (KZ) = 8.997 | IBI (India) = 4.260 |
| | JIF = 1.500 | SJIF (Morocco) = 5.667 | OAJI (USA) = 0.350 |

Release per shift 657 pair
 Labor intensity 13.9 minutes
 Average time the shoes are outside the process (WTO, drying of adhesive films, cooling) 72 min
 The maximum number of shoes being processed at the same time 121 pair
 Work in progress 60 pairs Shift duration 480 min

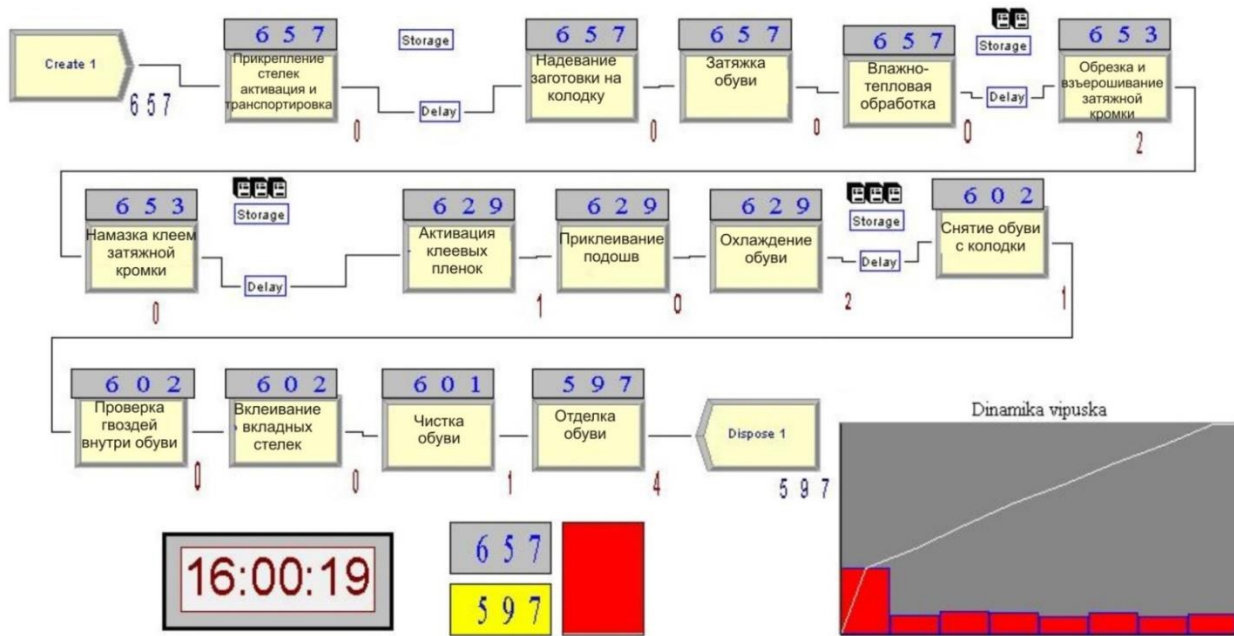

Figure: 18 - Simulation model of the shoe assembly technological process (RINK-system). Issue 657 pairs / shift

In the process of manufacturing leather goods, in relation to the objects of labor, certain chains of operations are performed for which the normative characteristics are known. In this case, the operation can be considered as a segment of the technological route, measured in units of standard labor intensity. Several operations can be combined into a generalized operation, which is presented as a single operation during management. Like an operation, a technological route has a beginning and an end. The time taken by the objects of labor from the beginning of the technological route to the end is called the technological cycle. The planned location of objects of labor on the technological route, being in the process of processing at some operation, can be

determined by the amount of labor costs calculated from the beginning or from the end of the technological route. Let's designate the technological cycle time $TЦ$,

We will put the X-axis in correspondence with the technological route of manufacturing the product, along which we will postpone the conditionally spatial coordinate of finding the objects of labor as the value of "accumulated labor intensity" (Fig. 19). A generalized operation corresponds to a certain interval of the X axis, for example, the j-th generalized operation corresponds to an interval $[x_j^H; x_j^K]$.

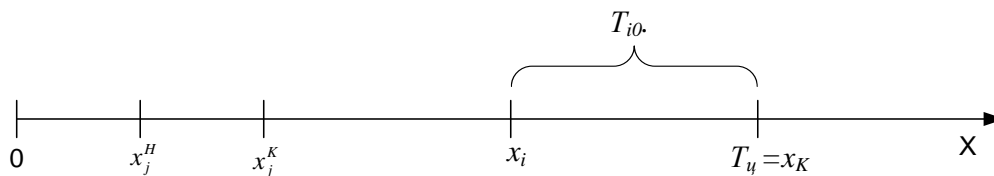

Figure: 19- X-axis showing the route of the product

Impact Factor:

| | | | | | |
|-------------------------|----------------|-----------------------|----------------|---------------------|----------------|
| ISRA (India) | = 4.971 | SIS (USA) | = 0.912 | ICV (Poland) | = 6.630 |
| ISI (Dubai, UAE) | = 0.829 | PIHIQ (Russia) | = 0.126 | PIF (India) | = 1.940 |
| GIF (Australia) | = 0.564 | ESJI (KZ) | = 8.997 | IBI (India) | = 4.260 |
| JIF | = 1.500 | SJIF (Morocco) | = 5.667 | OAJI (USA) | = 0.350 |

Let some object of labor "move" along the technological route. The law of its motion is described by the equation $x = x(t)$. This law fully characterizes the process of processing objects of labor on the technological route.

The purpose of simulation modeling of production flows is to identify bottlenecks, ensure the fulfillment of production targets at the best technical and economic indicators, which is possible with a rhythmic and reliable production of products to meet demand.

The developed simulation models allow carrying out experiments for the designed technological process. During the modeling process, some parts are queued, since the processing time for different technological operations differs. At any time, you can stop the process and look at the places where the specified equipment cannot cope and the queue is significant, therefore, it is necessary to reorganize the process by increasing the amount of equipment or changing the number of workers. With the help of simulation, it is possible to determine the amount of work in progress, determine the maximum number of products simultaneously in processing, and determine the time that shoes are out of the process.

In the simulation models presented in Figures 4.62 and 4.63, an example of a technological process for assembling shoes with the release of 560 pairs per shift is considered. After the launch of the model, it turned out that in the operations "Treating the soles with a solvent" and "Spreading the soles with glue" there is a delay in parts, leading to an increase in work-in-progress and the appearance of additional costs for the production of this model. After the introduction of an additional piece of equipment, work in progress decreased by 11 pairs, and the number of shoes in processing increased at the same time.

Based on the simulation results, it was revealed that a significant delay in the technological process occurs in walk-through machines at the operations of wet-heat treatment, drying of adhesive film and cooling of shoes. With the conveyor organization of production, queues are formed mainly in the operations "Inserting a backdrop and pre-molding of the heel part", "First and second spreading with glue of the lingering edge", "Sawing shoe tracks", "Attaching a shank", "Treatment of soles with a solvent", "Spreading of soles with glue", "Activation and gluing of soles", "Shoe shine". To increase the rhythm of the technological process, to eliminate queues at these operations, additional units of equipment were introduced into the technological chain, indicated on the simulation models by the "Decide" blocks. [20]

In the technological process of assembling footwear when using the RINK-system of production organization, where most of the preparatory operations are performed outside the work-in-process flow and the time spent on processing the footwear is reduced, which makes it possible to reduce the cost of all types of energy used in the production process, reduce labor intensity and thereby contribute to the receipt of additional profits by saving resources.

A brief description of the model and features of its manufacture (fig. 20)

Option 1: men's closed shoes made of smooth chrome-tanned leather, heel and toecap - thermoplastic, two-process tightening, molded thermoplastic elastomer sole (organization of production using a conveyor).

Option 2: men's closed shoes made of smooth chrome-tanned leather, back and toecap - thermoplastic, three-process tightening, molded thermoplastic elastomer sole (organization of production using a conveyor).

Option 3: men's closed shoes made of smooth chrome-tanned leather, back and toecap - thermoplastic, two-process tightening, molded TPE sole (production organization without a conveyor).

Calculation of a comprehensive performance indicator shoe assembly technological process.

Consider the multi-criteria problem of choosing the best technological process. The first group of criteria to be minimized includes: "labor intensity", "wage losses per unit of capacity, rubles", "specific reduced costs per unit of capacity, rubles", "work in progress", "technological cost". The second group of criteria to be maximized includes: "labor productivity of 1 worker, pairs / shift", "workload factor of workers, %", "release per shift, pairs" (Tables 2 - 4).

In the conditions of a real shoe enterprise, the criteria for the importance of technological process indicators can take different values. In each specific case, their value is determined by expert methods.

The choice of the best technological process is carried out under the condition of the same significance of the criteria given in Tables 5 - 9, and provided that one set of criteria is more important than the other, for example: the criterion "technological cost" is more important than the criterion "labor intensity" with a coefficient of 0.5 ($\theta_{51} = 0.5$) and the criterion "work in progress" is more important than the criterion "unit reduced costs" with a coefficient of 0.3 ($\theta_{43} = 0.3$).

Impact Factor:

| | | |
|--------------------------|------------------------|----------------------|
| ISRA (India) = 4.971 | SIS (USA) = 0.912 | ICV (Poland) = 6.630 |
| ISI (Dubai, UAE) = 0.829 | ПИИЦ (Russia) = 0.126 | PIF (India) = 1.940 |
| GIF (Australia) = 0.564 | ESJI (KZ) = 8.997 | IBI (India) = 4.260 |
| JIF = 1.500 | SJIF (Morocco) = 5.667 | OAJI (USA) = 0.350 |



a)



b)



c)

**Figure: 20 - Model sketches:
a) option 1; b) option 2; c) option 3**

Table 2 - Summary table of technical and economic indicators of options for technological processes of shoe assembly

| Options technological process | Release per shift, steam | Labor intensity, min | Estimated amount workers, people | Labor productivity 1 worker, couples / shift | Load factor workers, % | Loss of wages per unit of power, rub. | Specific reduced costs per 100 pairs, rub. | Unfinished production, steam | Technological cost price for a pair of shoes, rub. | Number of operations in the technological process |
|-------------------------------|--------------------------|----------------------|----------------------------------|--|------------------------|---------------------------------------|--|------------------------------|--|---|
| | | | | | | | | | | |

Impact Factor:

| | | |
|--------------------------|------------------------|----------------------|
| ISRA (India) = 4.971 | SIS (USA) = 0.912 | ICV (Poland) = 6.630 |
| ISI (Dubai, UAE) = 0.829 | PIHIQ (Russia) = 0.126 | PIF (India) = 1.940 |
| GIF (Australia) = 0.564 | ESJI (KZ) = 8.997 | IBI (India) = 4.260 |
| JIF = 1.500 | SJIF (Morocco) = 5.667 | OAJI (USA) = 0.350 |

| | | | | | | | | | | |
|---------------------------|-----|-------|-------|-------|-------|------|---------|----------|-------|----------|
| Option 1 (using conveyor) | 560 | 19.35 | 22.58 | 25.28 | 71.47 | 5.74 | 4610.96 | 70 | 28.18 | 31 |
| Option 2 (using conveyor) | 560 | 20.95 | 24.44 | 22.91 | 71.89 | 6.21 | 5037.50 | 89 | 30.97 | 33 |
| Option 1 (Rink system) | 548 | 13.9 | 15.84 | 37.59 | 76.73 | 2.93 | 3531.46 | fourteen | 21.49 | nineteen |

Table 3 - Summary table of technical and economic indicators of the shoe assembly technological process (option 1) taking into account the production program

| Short description model and features its manufacture | Release per shift, steam | Labor intensity, min. | Estimated amount workers, people | Labor productivity 1 worker, couples / shift | Load factor workers, % | Loss of wages per unit of power, rub. | Specific reduced costs per 100 pairs, rub. | Unfinished production, steam | Technological cost price for a pair of shoes, rub. | Number of operations in the technological process |
|---|--------------------------|-----------------------|----------------------------------|--|------------------------|---------------------------------------|--|------------------------------|--|---|
| Closed-toe shoes for men made of smooth chrome-tanned leather, thermoplastic heel and toecap, two-process tightening, molded thermoplastic elastomer sole (organization of production using a conveyor) | 560 | 19.35 | 22.58 | 25.28 | 71.47 | 5.74 | 4610.96 | 70 | 28.18 | 31 |
| | 606 | | 24.43 | | 70.51 | 6.02 | 4835.99 | 84 | | |
| | 636 | | 25.64 | | 68 | 6.77 | 4911.94 | 112 | | |
| | 651 | | 26.23 | | 66.04 | 7.4 | 4974.93 | 127 | | |
| | 763 | | 30.76 | | 73.62 | 5.15 | 4411.85 | 105 | | |
| | 812 | | 32.73 | | 74.71 | 4.87 | 4290.87 | 123 | | |

Table 4- Summary table of technical and economic indicators of the shoe assembly technological process (option 2) taking into account the production program

| Brief model description and features its manufacture | Release per shift, steam | Labor intensity, min | Estimated number of workers, people | Labor productivity 1 worker, couples / shift | Worker load factor, % | Loss of wages per unit of power, rub. | Specific reduced costs per 100 pairs, rubles | Work in progress, steam | Technological cost per pair of shoes, rub. | Number of operations in the technological process |
|--|--------------------------|----------------------|-------------------------------------|--|-----------------------|---------------------------------------|--|-------------------------|--|---|
| | | | | | | | | | | |

Impact Factor:

| | | |
|---------------------------------|-------------------------------|-----------------------------|
| ISRA (India) = 4.971 | SIS (USA) = 0.912 | ICV (Poland) = 6.630 |
| ISI (Dubai, UAE) = 0.829 | ПИИИ (Russia) = 0.126 | PIF (India) = 1.940 |
| GIF (Australia) = 0.564 | ESJI (KZ) = 8.997 | IBI (India) = 4.260 |
| JIF = 1.500 | SJIF (Morocco) = 5.667 | OAJI (USA) = 0.350 |

| | | | | | | | | | | |
|--|-----|-------|-------|-------|-------|------|---------|-----|-------|----|
| Men's closed shoes made of smooth chrome-tanned leather, thermoplastic heel and toe, three-process tightening, molded thermoplastic elastomer sole (organization of production using a conveyor) | 560 | 20.95 | 24.44 | 22.91 | 71.89 | 6.21 | 5037.5 | 89 | 30.97 | 33 |
| | 606 | | 26.45 | | 69.6 | 6.93 | 5339.14 | 109 | | |
| | 651 | | 28.41 | | 67.7 | 7.57 | 5391.36 | 112 | | |

The origin of coordinates $0 = (0,0)$ is taken as an ideal vector. Euclidean distance is used as a metric with a vector $a = (1,1)$ having the same components, since the relative importance of the criteria was taken into account earlier.

Thus, according to Table 5, three variants of the technological process with a set of technical and economic indicators (n-dimensional vectors) were obtained, for which an assessment of their effectiveness is required:

- Y1 = (19.35; 5.74; 46.11; 70; 28.18)
- Y2 = (20.95; 6.21; 50.37; 89; 30.97)
- Y3 = (13.9; 2.93; 35.31; 14; 21.49) and
- Y'1 = (25.28; 71.47; 560)
- Y'2 = (22.91; 71.89; 560)
- Y'3 = (37.59; 76.73; 548)

Criteria "labor intensity", "specific reduced costs per unit of power, rubles." are subject to minimization. In accordance with the above conditions, we recalculate the possible vectors. As a result, we get:

Initial values of the criteria for the first group:

| | | | | |
|-------|------|-------|----------|-------|
| 1 | 2 | 3 | 4 | five |
| 19.35 | 5.74 | 46.11 | 70 | 28.18 |
| 20.95 | 6.21 | 50.37 | 89 | 30.97 |
| 13.9 | 2.93 | 35.31 | fourteen | 21.49 |

Initial values of the criteria for the second group:

| | | |
|-------|-------|-----|
| 1 | 2 | 3 |
| 25.28 | 71.47 | 560 |
| 22.91 | 71.89 | 560 |
| 37.59 | 76.73 | 548 |

Modified values of the criteria for the first group:

| | | | | |
|--------|------|--------|----------|-------|
| 1 | 2 | 3 | 4 | five |
| 23,765 | 5.74 | 34,833 | 70 | 28.18 |
| 25.96 | 6.21 | 41,811 | 89 | 30.97 |
| 17,695 | 2.93 | 14,793 | fourteen | 21.49 |

As a result, we get the following efficiency values:

| | | | |
|--------------------------------------|----------|-----------------------------------|----------|
| A) according to the initial criteria | | B) according to modified criteria | |
| P1 = | 71.81079 | P1 = | 70.62705 |
| P2 = | 90.10926 | P2 = | 89.5294 |
| P3 = | 36.00756 | P3 = | 23.75512 |
| P'1 = | 44.57601 | | |
| P'2 = | 44.57613 | | |
| P'3 = | 44,00828 | | |

from which, according to the method of target programming, it follows that vector No. 3 is the best, i.e. The technological process with the above initial parameters is preferable, although in the first and second cases the output of the process will be the same result.

Technological processes for assembling footwear (option No. 1, No. 2), taking into account the

shift program (Tables 4.9 and 4.10), were evaluated according to the criteria: "estimated number of workers, people", "loss of wages per unit of capacity, rubles", "specific reduced costs per unit of capacity, rubles.", "work in progress, steam", "workload factor of workers,%" ($\theta_{31} = 0.5, \theta_{34} = 0.5$).

| | | | |
|-----------------------|---------------------------------|-------------------------------|-----------------------------|
| Impact Factor: | ISRA (India) = 4.971 | SIS (USA) = 0.912 | ICV (Poland) = 6.630 |
| | ISI (Dubai, UAE) = 0.829 | ПИИИ (Russia) = 0.126 | PIF (India) = 1.940 |
| | GIF (Australia) = 0.564 | ESJI (KZ) = 8.997 | IBI (India) = 4.260 |
| | JIF = 1.500 | SJIF (Morocco) = 5.667 | OAJI (USA) = 0.350 |

For a process using two-way tightening and similar criteria values:

| | | 1 | 2 | 3 | 4 | five |
|------|-----|-------|------|-------|-----|-------|
| 1 | 560 | 22.58 | 5.74 | 46.11 | 70 | 71.47 |
| 2 | 606 | 24.43 | 6.02 | 48.35 | 84 | 70.51 |
| 3 | 636 | 25.64 | 6.77 | 49.12 | 112 | 68 |
| 4 | 651 | 26.23 | 7.4 | 49.75 | 127 | 66.04 |
| five | 763 | 30.76 | 5.15 | 44.12 | 105 | 73.62 |
| 6 | 812 | 32.73 | 4.87 | 42.91 | 123 | 74.71 |

Modified criteria values:

| | | 1 | 2 | 3 | 4 | five |
|------|-----|--------|------|-------|--------|-------|
| 1 | 560 | 47.025 | 5.74 | 46.11 | 58,055 | 71.47 |
| 2 | 606 | 47.47 | 6.02 | 48.35 | 66,175 | 70.51 |
| 3 | 636 | 46.82 | 6.77 | 49.12 | 80.56 | 68 |
| 4 | 651 | 46,135 | 7.4 | 49.75 | 88,375 | 66.04 |
| five | 763 | 52.19 | 5.15 | 44.12 | 74.56 | 73.62 |
| 6 | 812 | 53.72 | 4.87 | 42.91 | 82,955 | 74.71 |

Based on the results of evaluating the effectiveness, the following complex values were obtained:

A) according to the initial criteria B) by modified criteria

| | |
|---------------|---------------|
| P1 = 82.23031 | P1 = 78.40344 |
| P2 = 90.87589 | P2 = 81.1405 |
| P3 = 114,142 | P3 = 88.26741 |
| P4 = 128,1872 | P4 = 93.53851 |
| P5 = 108.6204 | P5 = 87,12891 |
| P6 = 125,1194 | P6 = 92.7091 |

from which it follows that the technological process with a shift program of 560 pairs of footwear production will be effective, despite the fact that, according to table 4.9, the single indicators of this

option are "mechanization coefficient", "wage losses" and "Specific reduced costs per 100 pairs, rub." not the most preferred.

For a technological process using a three-way tightening and similar criteria values:

| | | 1 | 2 | 3 | 4 | five |
|---|-----|-------|------|-------|-----|-------|
| 1 | 560 | 24.44 | 6.21 | 50.37 | 89 | 71.89 |
| 2 | 606 | 26.45 | 6.93 | 53.39 | 109 | 69.6 |
| 3 | 651 | 28.41 | 7.57 | 53.91 | 112 | 67.7 |

Modified criteria values:

| | | 1 | 2 | 3 | 4 | five |
|---|-----|--------|------|-------|--------|-------|
| 1 | 560 | 48,165 | 5.74 | 46.11 | 69,685 | 71.47 |
| 2 | 606 | 48.025 | 6.02 | 48.35 | 81,195 | 70.51 |
| 3 | 651 | 48,055 | 7.4 | 49.75 | 82,955 | 66.04 |

A) according to the initial criteria B) by modified criteria

| | |
|---------------|---------------|
| P1 = 95.24282 | P1 = 83.1536 |
| P2 = 111.7995 | P2 = 89.6516 |
| P3 = 114.3124 | P3 = 89.50895 |

The considered approach allows, on the basis of the production program, to form promising options for technology and equipment, to choose the most efficient one and, on this basis, to create technological

systems for this particular multi-assortment flow, to identify opportunities for improving the flow, eliminate bottlenecks, minimize equipment

Impact Factor:

| | | |
|--------------------------|------------------------|----------------------|
| ISRA (India) = 4.971 | SIS (USA) = 0.912 | ICV (Poland) = 6.630 |
| ISI (Dubai, UAE) = 0.829 | ПИИИ (Russia) = 0.126 | PIF (India) = 1.940 |
| GIF (Australia) = 0.564 | ESJI (KZ) = 8.997 | IBI (India) = 4.260 |
| JIF = 1.500 | SJIF (Morocco) = 5.667 | OAJI (USA) = 0.350 |

downtime, which is one of the conditions designing flexible technological processes.

The reliability of the calculations for assessing the effectiveness of technological processes by methods of target programming for various technological and organizational solutions is confirmed by calculations of indicators of economic efficiency: cost, profit and profitability, etc.

The most generalizing indicator characterizing the use of fixed assets is capital productivity, which is determined by the ratio of the volume of sales to the value of fixed assets.

In connection with the improvement of the technological process and forms of organization of production: the absence of capital costs for some types

of equipment, the conveyor and their reduction for the building, the return on assets increased by 21%.

The reorganization of the technological process and the absence of a conveyor reduced the installed capacity from 108.46 to 57.6 kW, which led to a reduction in electricity consumption for technological needs. The decrease in production area ensured a decrease in annual lighting costs from 39,152.16 to 29,918.16 rubles. The volume of shoe storage facilities and the volume of work in progress were halved.

The results of calculating the cost of a calculation unit (100 pairs) for the options of the technological process are shown in Table 5.

Table 5- Calculation of the cost by options of the technological process

| Name indicator | Unit of measurement | Indicator value | | |
|---|---------------------|-----------------------------|-----------------------------|------------------------|
| | | option 1 (using a conveyor) | Option 2 (using a conveyor) | option 1 (Rink system) |
| 1. Release, steam | steam | 560 | 560 | 548 |
| 2. Number working workers | people | 36 | 39 | 25 |
| | | thirty | 33 | nineteen |
| 3. Development 1 working | steam | 15.52 | 14.29 | 22.21 |
| 1 worker | | 18.61 | 16.87 | 29.34 |
| 4. Average monthly salary 1 working | rub. | 9484.60 | 8808.78 | 13213.22 |
| 1 worker | | 8641.17 | 7922.28 | 13052.31 |
| 5. Cost of one pair | rub. | 517.49 | 519.91 | 515.22 |
| 6. Profit | rub. | 75.73 | 73.31 | 78.01 |
| 7. Profitability | % | 14.64 | 14.10 | 15.14 |
| 8. Costs per 1 ruble of marketable products | cop. | 73.93 | 74.27 | 73.60 |
| 9. Capital productivity | % | 8.08 | 7.63 | 9.26 |

Cost reduction occurs for the following items:

- basic and additional wages for production settlements with the OESN;
- fuel and electricity for technological needs;
- equipment maintenance and operation costs;

- general production costs.

According to table 5, the calculation of the cost reduction for each model is made, the results are summarized in table 6

| | | | |
|-----------------------|--------------------------|------------------------|----------------------|
| Impact Factor: | ISRA (India) = 4.971 | SIS (USA) = 0.912 | ICV (Poland) = 6.630 |
| | ISI (Dubai, UAE) = 0.829 | ПИИИ (Russia) = 0.126 | PIF (India) = 1.940 |
| | GIF (Australia) = 0.564 | ESJI (KZ) = 8.997 | IBI (India) = 4.260 |
| | JIF = 1.500 | SJIF (Morocco) = 5.667 | OAJI (USA) = 0.350 |

Table 6 - The results of calculations to reduce the total cost as a result of the implementation of organizational and technical measures

| Option technological process | Decrease amount full cost, rub. |
|------------------------------|---------------------------------|
| Option 1 (using a conveyor) | 2.42 |
| Option 2 (using a conveyor) | Baseline |
| Option 1 (Rink system) | 4.69 |

The economic calculations carried out confirm the feasibility and legitimacy of the use of a multi-criteria method for assessing the effectiveness of technological processes. The proposed method, in comparison with the standard calculation of the total cost of making shoes, is less laborious and allows at

the main stages of developing a new assortment (technical task, design documentation, prototype) to reduce the time of expert work while maintaining the required depth and validity of engineering conclusions.

References:

- (2017). *The concept of import substitution of light industry products: preconditions, tasks, innovations*: monograph / VT Prokhorov [and others]; under the general editorship of Doctor of Engineering Sciences. Sciences, professor V. T. pro-khorov; Institute of Services and Entrepreneurship (branch) of the Don State Technical University. (p.334). Mines: ISOiP (branch) DSTU.
- (2018). *Management of the real quality of products and not advertising through staff motivation behavior of the head of a collective enterprise of light industry*: monograph / OA Surovtseva [and others]; under the general editorship of Doctor of Engineering Sciences. Sciences, professor V. T. Prokhorov; Institute of Services and Entrepreneurship (branch) of the Don State Technical University. (p.384). Novo-Cherkassk: USU (NPI).
- (1975). *Hegelian Encyclopedia of Philosophical Sciences*, T. 1. Science of Logic: Translation from English Djeman M., "Thought", (p.452).
- Engels, F. (1961). Anti-Dühring. K. Marx and Friedrich E.: sobbing. archive: Ed. m. Gospolitizdat, t. 20, (p.827).
- (2004). *Philosophical and social aspects of quality* // BS Aleshin, L. N. Aleksandrovsкая, V. I. Kruglov, A. M. Sholom. (p.438). Moscow: Logos.
- Ricardo, D. (1955). *The beginning of political economy and taxation*. Coll. Op. in 3 t, gt 1, (p.360). Moscow: Gospolitizdat.
- Galbait, J. (1969). *New Industrial Society*, (p.480). Moscow: Progress.
- F. de P. Hanika (p.1969). *New ideas in the field of management*. (p.124). Moscow: Progress.
- Beer, S. (1965). *Cybernetics and Production Management*. (p.287). Moscow: Nauka.
- Aleshin, B.S., et al. (2004). *Philosophical and social aspects of quality*. (p.438). Moscow: Logos.
- Adler, Yu.P., et al. (1999). What is the coming century for us? (Management of the 21st century - a brief overview of the main trends). *Reliability and quality control*, No. 1.
- Boytssov, B.V., et al. (2007). *Concept of quality of life*. (p.240). Moscow: Academy of quality problems.