



Low Cost Automated Machine for Paper Gathering and Folding

Thivanka Kasun Gunawardena, P R Dadigamuwa and B G D A Madhusanka

Department of Mechanical engineering, The Open University of Sri Lanka, Sri Lanka
bgmad@ou.ac.lk

ABSTRACT

The present study was to design and development of a low cost, automated machine which performs gathering, folding, stamping and processing neatly with a high speed. The machine consists of accuracy gathering detector, paper jam detector and preset counting system. It is supposed to gather two papers and fold them into letter or Z fold. The paper gathering, folding and stamping functions were automated by using an electromechanical motor driven system. Almost all the single paper gathering and folding machines currently available in the market are very expensive. Also none of the machines found with the stamping mechanism. Initial cost for this automated system is very low and running and maintaining costs are also low. This automated system is portable and capable of working independently without much human intervention. Selected materials for the system are also durable and the machine is less of disruptions. Therefore continuous running is possible. Also selected sensors and Arduino control board for the system are very common and inexpensive.

Key words: Automated, paper gathering, folding, arduino, low cost

INTRODUCTION

A letter is a written message containing information from one party to another. Letters are one of the vastly used techniques to pass the information. It's also the legitimate way of communicating between firms, institutions, people's etc. Letters are the most suitable way to communicate with any person who does not familiar with communication systems like e-mails, SMSs and other modern communication systems. On the other hand, letters only need few basic requirements, like writing materials and it's also the most suitable way to communicate with hard copy.

Written documents are still being used in any company even though e-documents have invaded every corner of official fields. Especially in firms like financial, legal and academic, daily thousands of letters are roaming inside and as well as all over the country for various tasks. Staff members have to consume lot of time and energy to prepare letters. When an urgent situation comes it is a difficult task to prepare large number of letters promptly [1]. Furthermore gathering and folding can be added considerable time to the process. However, purchasing of an Automated Paper Gathering and Folding Machine may cost a lot. Therefore preparing an efficient, meticulous, professional and accurate Automated Paper Folding Machine would be a reliable solution for the grown up problem.

RATIONALE FOR STUDY

The Open University of Sri Lanka (OUSL) is an academic institution where annually hundreds of, thousands of letters are roaming here and there for various tasks such as information about the registrations, payment bills, examination admissions, timetables, results sheets etc. Within the OUSL these letters were prepared by the university staff dedicated exclusively. This is of course a time consuming work that utilizes lot of energy as well. But, when emergency situations like rescheduling activities, it is a difficult task to prepare large number of letters promptly. In cases like these, automated paper folding machine is helpful to increase the efficiency of letter preparation activity, quality of finishing, counting the number of finished letters and many other benefits [1].

Buy an automated paper gathering and folding machine is a good solution for this problem. Paper folding machines, also known as letter folders, are designed to do this folding task automatically. This machine is very useful to firms or companies that produce large amount of statements, brochures, letters or invoices daily. Some paper folder or letter folder has the ability to fold 1,800 to 18,000 papers or letters per hour. A paper folding machine or letter folding machine is perfect for above situation. But unfortunately, the costs of these machines are

very high (ex: - MBM 307A Paper Folder and HEFTER TF Multi Plus automated). Buying automated machine for every sub department in OUSL is not practical because it may cost lot of money.

METHODOLOGY

Automated paper gathering and folding machine mainly consists of paper gathering, paper feeding, paper folding, and stamping mechanisms. Firstly, friction feed method was used to make the paper feeding mechanism in proposed machine. Using friction feeding method is simple but this method decreases the ability of feeding un-fanned or glossy papers. Since fanning is not a more time consuming work and also glossy papers are not often uses in OUSL friction feed method was selected [2].

Feed tray is the first part use in the paper folding process. This is where operator stacks the sheets needed to be folded. Depending on folder, the tray may be hold few sheets or few hundred sheets. The input tray consist a screw adjustment to make sure that feeding sheets are properly fed. If misalignment is created in folding, it increases the risk of paper jamming. Folded documents come out of the machine are not properly done then this is the first place to make adjustments. In this folding machine it is decided to use feeding rollers with one rubber wheel [6]. This rubber wheel improves the friction of the feeder than the other materials and also reduces misaligning errors in feed engager. Every feed plate consists with feed roller, directly run by small direct current motor [7].

Secondly, the machine was designed to create letter folding and Z folding types. Paper folding mechanism was used as buckle folding method as shown in Fig.1. It is the most suitable mechanism for this system due to several advantages such as high speed folding fast, accurate, low cost and also consists with simple mechanism. It's also helps to reduce the size and improve the reliability of the machine. There is no need of detections or cyclic repetitive linear motions while folding. Buckle folding is the most using technique in most of the other desktop paper folding machines [3].

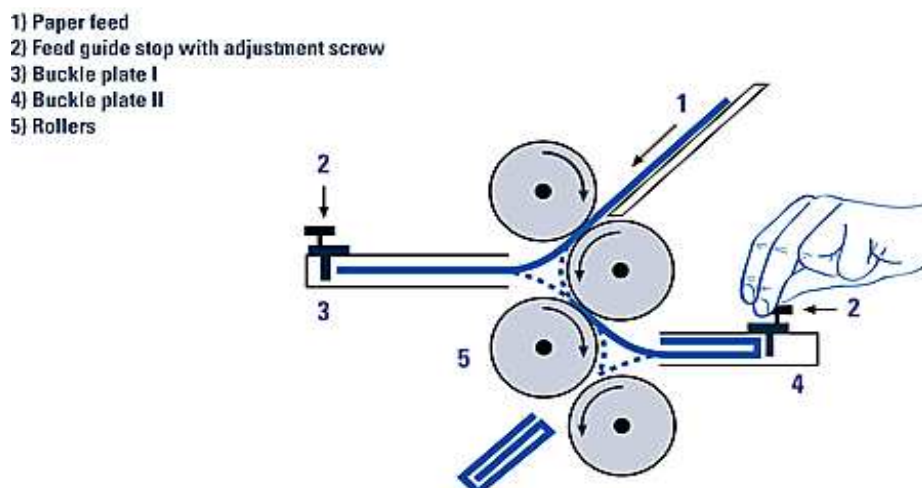

Fig. 1 Buckle folding method

Power transmission using plastic gears is the most suitable method for rollers. The most important advantages of using plastic gears are ability to operate with minimum or no lubrication, lightweight, low inertia, corrosion-resistance and quietness of operation. Toothed belt was selected for this machine. Tooth belts have teeth that fit into a matching toothed pulley. When correctly tensioned, they have no slippage and are often used to transfer direct motion for indexing or timing purposes. Toothed belts with a helical offset tooth design are available. The helical offset tooth design forms a chevron pattern and causes the teeth to engage progressively. Belts normally transmit power only on the tension side of the loop.

Main task of the two rollers as shown in No.5 in Fig.1 are to feed single paper or gathered paper set to the folding process. The front view and the back view of the paper gathering and folding machine are shown in Fig.2 and Fig.3. These rollers are operated by single motor. While feeding papers by two feed rollers, papers can misalign due to un-expected slipping between feeding roller with paper and asynchronous paper feeding of both rollers. These two rollers improve the neatness of the folded paper set. For neat and proper folding, these two papers should lay on each other perfectly [4]. Otherwise it produces inefficiently folded documents. The system combined with fold engaged rollers would eliminate that problem.

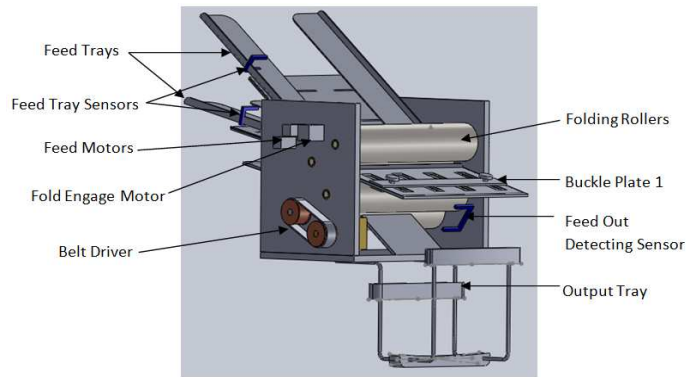

Fig. 2 Front view of the paper gathering and folding machine

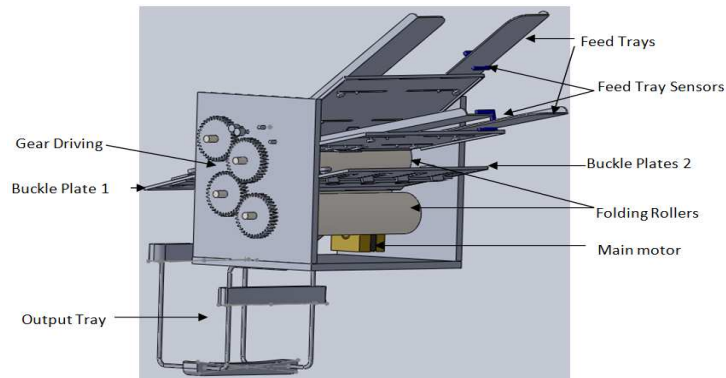

Fig. 3 Back view of the paper gathering and folding machine

A detection sensor is used to detect the gathered papers as shown in Fig.4. Considering speed of the feeding motors and distance between sensor and engage rollers time taken by papers to reach engage rollers could be calculated. To have a proper fold, the rollers should active with that stipulated time. To avoid above mentioned misalignment rollers may start to function with a short time delay. Then it holds the first paper for a moment and next paper can join it directly. Here it is planned to use rollers made with Steel and Rubber. Steel reduces the deflection when rollers ceases to load and its weight also help to create neat folded paper set. These two steel rollers are loaded with springs to make small movement according to thickness of the paper set which pass between them. Surface of these two metal rollers roughed by nailing them [5]. The outer surface of other two rollers design to cover with rubber. Rubber can grab the papers more effectively and softness of the rubber surface also enables to have extra gap between rollers while passing set of paper or folded thicker paper set. Finally, stamp a date, it is easy to use. A proximity sensor is used to detect feed document inserting it into the stamp and once the sensor is triggered, stamping roller will stamp the document as shown in Fig.5. This machine features an adjustable stamping roller and an adjustable depth setting. Date stamping location and arrangement of the date is fixed to this machine.

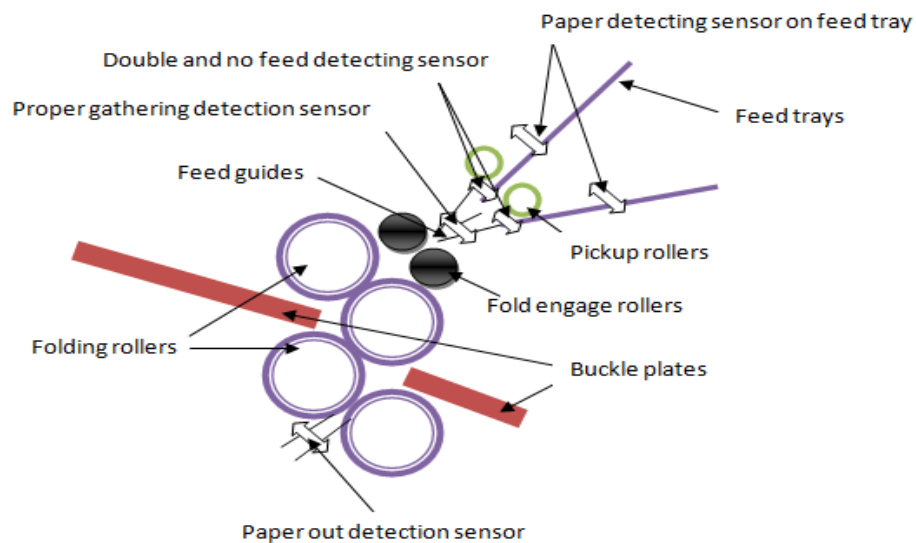

Fig. 4 Sensor arrangement and side view of conceptual design

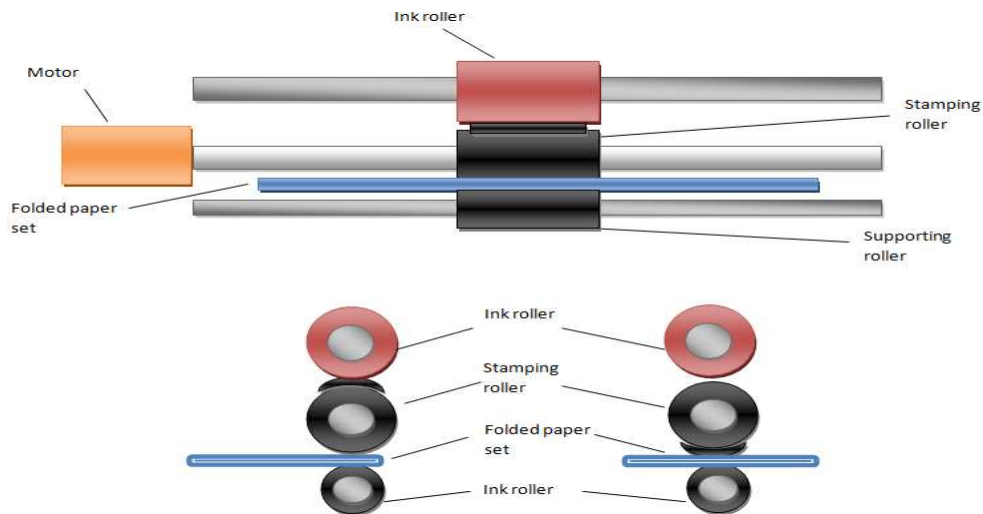

Fig. 5 Stamping mechanism

DISCUSSION AND CONCLUSION

Cost wise this machine is cheaper than the other machines. Most of the parts used in this machine are gathered from junk yards. There are thousands of machines like Photocopy machines, Printers, Roneo machines thrown out to junk yards which dealing with papers. The parts like rollers, feeders, gear wheels etc, of this machine were used from the thrown out yards. Most of the sensors used in this machine are inexpensive and simple. But they are well enough to do main tasks properly. Motors also used in this design can easily find in the junk yards or machine separating places. They can buy at low prices.

Main purpose of this study was to automate the letter preparation process in order to reduce the man power and to increase the efficiency and quality of the product and ultimately to increase the preparedness to face emergency situations. Newly designed automated letter folding machine consists of gathering, folding and stamping functions. The paper gathering, folding and stamping functions were automated by using an electromechanical motor driven system. The backup program can easily download to the controller using a simple USB connection when required modifications. As this system consists with AC to DC converter circuit, the machine can be directly connected to the conventional 230V power supply.

Almost all the single paper gathering and folding machines currently available in the market are very much expensive. Also none of the machines found with the stamping mechanism. Initial cost for this automated system is very less and running and maintaining costs are low as well. This automated system is portable and capable of working independently without much human intervention, and then the office use is also possible. Selected materials for the system are also durable and the machine is less of disruptions. Therefore continues running is possible. Also selected sensors for the system are very common and inexpensive. Arduino control board is inexpensive. By implementing the automated letter preparation system, staff members may able to improve their productivity. Furthermore the can be modified to fully automated system by adding the tabbing mechanism.

Acknowledgements

Authors are thankful to Department of Mechanical Engineering, The Open University of Sri Lanka for supporting to this work.

REFERENCES

- [1] L Wen, Y Xuekai, and Y Jin, *Design of Automated Packaging Machine*, Worcester Polytechnic Institute, **2006**.
- [2] A Colijn, *Automating and Improving the Printing Planning Process*, University of Twente, **2013**.
- [3] P Bowes, *Automate for Streamlined Mailing Process*, PB Australia Pvt Limited, **2012**.
- [4] G Venkateswaran, *Automation in Binding*, **2013**.
- [5] M L Pinedo, *Planning and Scheduling in Manufacturing and Services*. Springer, **2005**.
- [6] M L Pinedo, *Scheduling - Theories, Algorithms and Systems*. New York: Springer, **2012**.
- [7] R S Khurmi, *Theory of Machines*, 14th Edition. S Chand & Co Ltd, **2005**.