

# Performance of a 4- switch, 3-phase inverter fed induction motor (IM) drive system using MATLAB

A.Madusudhan<sup>1</sup>, Prof. M.Mahendran<sup>2</sup>

Student, Dept. of Electrical Engg, SCSVMV UNIVERSITY, Kanchipuram, Tamil Nadu, India<sup>1</sup>.

Assistant Professor, Dept. of Electrical Engg, SCSVMV UNIVERSITY, Kanchipuram, Tamil Nadu, India<sup>2</sup>.

## Abstract:

This project proposes the performance of a 4- switch, 3-phase inverter fed induction motor (IM) drive system for high performance industrial drive systems. In the proposed realization, instead of a usual 6-switch three-phase inverter (SSTPI) a 4-switch three-phase inverter (FSTPI) is used. A cost effective FSTPI fed IM drive using Field-Oriented-Control and Space-Vector PWM controller (with new control SVPWM approach) is implemented as a simulation model. This reduces the cost of the inverter, the switching losses, and the complexity of the control algorithms and interface circuits to generate 6 PWM logic signals. Furthermore, the proposed control approach reduces the computation for real-time implementation. In this paper, a simulation model of the drive system is developed and analyzed in order to verify the effectiveness of the approach. A performance comparison of the proposed IS3P inverter fed drive with a conventional 6S3P inverter fed drive is also made in terms of speed response and total harmonic distortion (THD) of the stator current. Simulation results show that the proposed drive system provides a fast speed response and good disturbance rejection capability. The designed inverter fed IM drive is found suitable considering its cost decrease.

**Keywords** — State FPGA-Field Programmable Gate Array, FSTPI- Four Switch Three Phase Inverter, IM-Induction Motor, PWM-Pulse Width Modulation, THD-Total Harmonic Distortion.

## I. Introduction:

Over the year's induction motor (IM) has been utilized as a workhorse in the industry due to its easy build, high robustness and generally satisfactory efficiency. By tradition, 6-switch 3-phase inverters have been widely used for variable speed IM drives. The last work on FSTPI for IM drives investigated the performance of a 4-switch, 3-phase inverter fed cost effective induction motor in simulation in MATLAB, which has been implemented by vector control. A standard three-phase voltage source inverter utilizes three legs [six-switch three-phase voltage source inverter], with a pair of complementary power switches per phase. The FSTPI structure generates four active vectors in the plane, instead of six, as generated by the stipe topology. A reduced switch count voltage source inverter [four switch three-phase voltage source inverter] uses only two legs, with four switches. Several articles report on FSTPI structure regarding inverter performance and switch control. This paper presents a general method to generate pulse width modulated (PWM) signals for control of four-switch, three phase voltage source inverters, even when there are voltage oscillations across the two dc-link capacitors. The

method is based on the so called space vector modulation, and includes the scalar version. This permits to implement all alternatives, thus allowing for a fair comparison of the different modulation techniques. The proposed method provides a simple way to select either three, or four vectors to synthesize the desired output voltage during the switching period. In the proposed approach, the selection between three or four vectors is parameterized by a single variable. The influence of different switching patterns on output voltage symmetry, current waveform, switching frequency and common mode voltage is examined.

## II. Proposed Technology:

The block diagram of the proposed system is shown in Fig.1. The drive system consists of a 3 phase AC supply, 3 phase Diode bridge Rectifier, 3 phase four switch Inverter, 3-phase Induction Motor and controlled circuits. The standard AC power supply is converted to a DC by using a 3-phase diode bridge rectifier. A voltage source FSTPI is used to convert the DC voltage to the controlled AC voltage. The output of FSTPI is fed to 3-phase induction motor. PWM pulses are given to FSTPI by triggering thyristors in MATLAB to drive the Induction

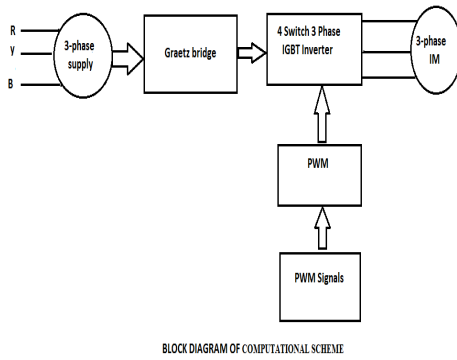

Motor at different speed.

### III. Principle of operation of FSTPI

The power circuit of the FSTPI fed IM drive is shown in Fig. 2. The FSTPI has 4 switches, namely S1, S2, S3 and S4 and a split capacitor. The switches are controlled in order to generate an AC output from the DC input. The two phases 'a' and 'b' are connected through two legs of the inverter, while the third phase 'c' is connected to the center point of the DC link capacitors, C1 and C2. The capacitance value of C1 and C2 are equal. It is assumed that the 4-power switches are denoted by the binary variables S1 to S4. The binary '1' corresponds to an ON state and the binary '0' corresponds to an OFF state. The states of the upper (S1, S2) and lower (S3, S4) switches of a leg are complementary that is  $S3 = 1 - S1$  and  $S4 = 1 - S2$ .

Considering a 3-phase Y-connected Induction Motor, the terminal voltages  $V_{as}$ ,  $V_{bs}$  and  $V_{cs}$  can be expressed as the function of the states of the upper switches as follows:

$$V_{as} = V_c / 3(4S1 - 2S2 - 1), \quad (1)$$

$$V_{bs} = V_c / 3(-2S1 + 4S2 - 1), \quad (2)$$

$$V_{cs} = V_c / 3(-2S1 - 2S2 + 2), \quad (3)$$

Where  $V_{as}$ ,  $V_{bs}$  and  $V_{cs}$  are the inverter output phase voltages. 'Vc' is the voltage across the DC link capacitors. 'Vdc' is the voltage across the capacitor C1 and C2 ( $V_{dc} = V_c/2$ ). S1, S2 are taken as the switching functions for the 2-switches. In matrix form the above equations can be written as:

Tab. 1 shows the different modes of operation and the corresponding output phase voltage vector of the FSTPI.

$$\begin{bmatrix} V_{as} \\ V_{bs} \\ V_{cs} \end{bmatrix} = \frac{V_c}{3} \begin{pmatrix} 4 & -2 \\ -2 & 4 \\ -2 & -2 \end{pmatrix} \begin{bmatrix} S_1 \\ S_2 \end{bmatrix} + \frac{V_c}{3} \begin{bmatrix} -1 \\ -1 \\ 2 \end{bmatrix}. \quad (4)$$

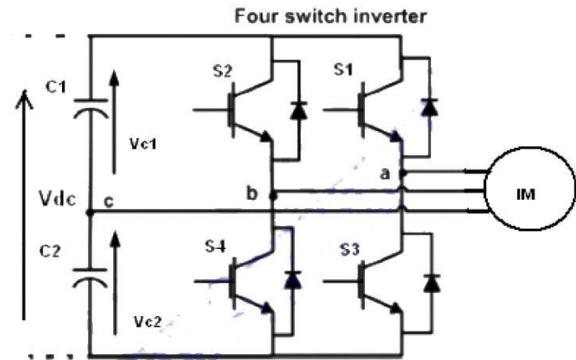

### IV. Simulation Of FSTPI fed IM drive:

The simulation model has been developed to test the proposed FSTPI fed IM drive by using MATLAB/Simulink.

These simulations were performed for a FSTPI fed IM drive at no load and load conditions. The drive system consists of a three phase diode bridge rectifier, a split capacitor, four switch three phase inverter, 3-phases squirrel cage Induction Motor. The parameter of Induction motor used in this simulation work is given in the Tab. 2

**Table 1.** Switching states and output phase voltages of FSTPI

Switching states		Output voltage		
$S_1$	$S_2$	$V_{as}$	$V_{bs}$	$V_{cs}$
0	0	$-\frac{V_c}{3}$	$-\frac{V_c}{3}$	$\frac{2V_c}{3}$
0	1	$-V_c$	$V_c$	0
1	0	$V_c$	$-V_c$	0
1	1	$\frac{V_c}{3}$	$\frac{V_c}{3}$	$-\frac{2V_c}{3}$

**Table 2.** Switching states and output phase voltages of FSTPI

Motor rating	0.5 Hp, 380V, 4-pole, 50 Hz
Stator resistance	11.1Ω
Stator inductance	18.8mH
Rotor resistance	12.3Ω
Rotor inductance	26.7mH
Magnetizing inductance	467mH
Inertia kg m <sup>2</sup>	0.01
Friction coefficient Kdf	0.02

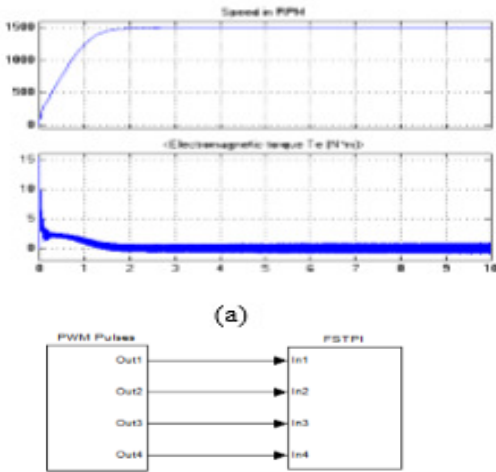

Fig. 3. Block diagram of PWM pulses with FSTPI in Simulink

Fig. 3 shows the PWM block and FSTPI fed IM. The PWM block provides the required PWM pulses for the 4 switches of FSTPI.

Fig. 4 shows the complete simulation circuit diagram of the system. The 3-phase output currents of FSTPI are shown in Fig. 5. A balanced 3-phase output current is obtained at the output of FSTPI speed (1500 rpm) at required speed in steady state at 2 second. At starting the torque increases and reaches at minimum value when the speed reaches at rated value. In Fig. 4, a 1KN load is applied at the motor terminal. It is observed that the speed of IM increased linearly from zero and reached at 1350 rpm at 3 second.

Fig. 6. Rotor speed in rpm and torque in N-m vs time in sec. (a) without load (b) with load

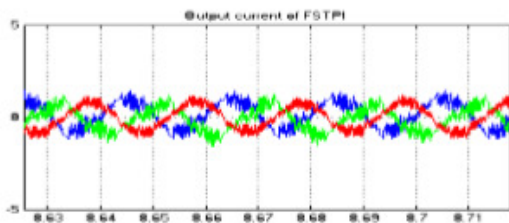
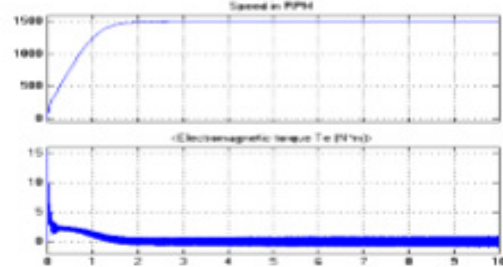

Fig. 5. Three phase current of FSTPI

## V. Conclusion:

The simulation of FSTPI fed IM drive is carried out successfully. In the simulation work the FSTPI fed induction motor is simulated with load and without load conditions. The results are obtained such as the speed and torque characteristics of induction motor are found



(a)

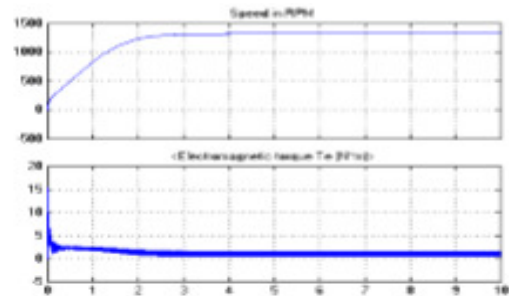

(b)

satisfactory.

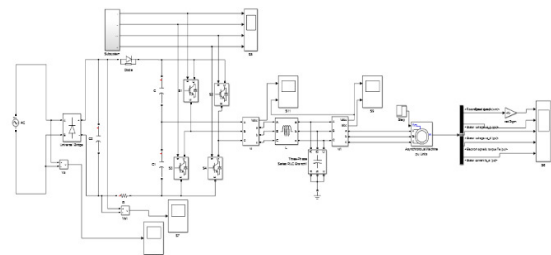

## VI. REFERENCES:

- [1] Matlab, simulink user guide. Math Works Inc, 2014a
- [2]. Bose B.K., Power Electronics and AC Drives, Englewood Cliffs, NJ: Prentice Hall, 1986