



## Evaluation of Methane Adsorption on the Modified Zeolite 13X

M. Anbia\*, A. Sedighi, S. Salehi

Research Laboratory of Nanoporous Materials, Faculty of Chemistry, Iran University of Science and Technology, Farjam Street, Narmak, P.O. Box 16846-13114, Tehran, Iran

### P A P E R I N F O

#### Paper history:

Received 01 January, 2016

Accepted in revised form 20 March 2016

#### Keywords:

Zeolite 13X  
Methane  
ion exchange  
global warming

### A B S T R A C T

In this study nano structured zeolite 13X as adsorbent for methane gas was used. Ni and Al ions were used to modify the pores of the zeolite and the methane gas adsorption capacity was measured at room temperature and pressure between 1 to 12 bars. The textural properties and structure order of the zeolite were studied by XRD and nitrogen adsorption-desorption analysis. Inductive coupled plasma (ICP) technique was used to determine the amounts of metals loaded on the zeolite.

doi: 10.5829/idosi.ijee.2016.07.03.02

## INTRODUCTION

Nowadays use of new and clean fuels is sharply increasing because of the disadvantages of usage of fossil fuels such as greenhouse gases emission into atmosphere. Naturally, methane in atmosphere will react and removed by natural process. The oxidation of methane as a greenhouse gas by hydroxyl radicals in the troposphere leads to the formation of formaldehyde, carbon monoxide and ozone in the presence of sufficiently high levels of nitrogen oxides (NO<sub>x</sub>). Hydroxyl radical (OH<sup>o</sup>) is a key species in atmospheric photochemistry. In the lower atmosphere, up to ~30% of the primary OH radical production is attributed to the photolysis of nitrous acid (HONO), and field observations suggest a large missing source of HONO. The main OH radicals are produced in atmosphere by following three reactions [1]:

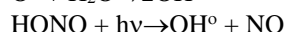
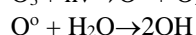
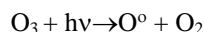

The main natural methane sources on earth are the wetlands (71%), termites (13%), oceans (6%) and other sources (6%). Methane is also emitted during the extraction of fossil fuels such as petroleum, coal and

natural gas. Based on recent researches the amount of methane released by human activities is about 275 TgCH<sub>4</sub>/year, while total natural sources are around 160 TgCH<sub>4</sub>/year [2]. The main content of methane in the earth atmosphere reacts by OH group and is removed from the atmosphere. This reaction will remove 500Tg methane in each year from the earth atmosphere. Like the other greenhouse gases, methane adsorbs terrestrial radiation and traps the heat in the atmosphere. This is called the greenhouse effect. The balance between the absorbed solar radiation and the emitted infrared radiation determines the net radiative forcing on climate [3].

Methane can also indirectly influence the climate by changes in the other compound concentration like OH group, ozone and CO<sub>2</sub>. Change in tropospheric ozone is the most important indirect effect of methane on human life. Global warming potential (GWP) of methane is about 24 times greater than CO<sub>2</sub>. The GWP is defined as the time-integrated commitment to climatic forcing from the instantaneous release of a kilogram of the gas relative to the climatic forcing from the release of 1 kg of carbon dioxide, and is generally calculated for constant background concentrations.

Much works have been done all over the world to decrease the amount of methane and the other greenhouse

\* Corresponding author: M. Anbia

E-mail: anbia@iust.ac.ir; Tel: +98 21 77240516; Fax: +98 21 77491204

gases release to the atmosphere. Reaction of methane by a reagent like OH or CO<sub>2</sub> [4-9], uses of methane membrane in industries and the use of methane adsorbent to trap greenhouse gas and store them later [10-15]. Large amount of methane cannot be removed by such process. Increase of greenhouse gas specially methane in earth atmosphere causes increase in earth temperature [2]. The growth of methane amount which is trapped in the earth atmosphere has sharply increased [16]. The concentration of methane in atmosphere was on increasing trend till Kyoto Protocol signed by 187 countries in 1997, in Japan and industrialized countries have decided to decrease the amount of greenhouse gases to 5% within 10 years. Therefore, many endeavors have been made to decrease the methane concentration in earth atmosphere.

The methane adsorbents can be divided in two groups; organic and inorganic materials. Carbonic adsorbent and metal organic frameworks belong to the organic group. Zeolites are the major members of inorganic adsorbent that have many properties which makes them one of the most important adsorbent in wide industrial applications [17-20]. Zeolites are crystalline aluminosilicates with framework forming channels with tetrahedral unit of AlO<sub>4</sub> and SiO<sub>4</sub> and are fundamentally ion exchangers [6, 21, 22]. Zeolites are usually synthesized with Na ion and the other ions loaded by ion exchange process. Each ion can changes the zeolite pores mechanical and electronic properties and can modify for special application like adsorbent or catalyst [7, 23-26]. Zeolites are classified based on the pore size and type of the crystalline and physical properties [17-2017-20]. The X type zeolites have the largest pores and the largest gas adsorption capacity, so we can use them as useful adsorbents. In this study we loaded Ni and Al ion on the zeolite-13X by ion exchange process to investigate the methane adsorption capacity of the modified zeolites at room temperature and the pressure between 1 to 12 bars.

## MATERIALS AND METHODS

### Preparation of modified zeolite-13X

Granola zeolite 13X (Na loaded) was used as adsorbent. In ion exchange step, Al(NO<sub>3</sub>)<sub>3</sub>.9H<sub>2</sub>O and Ni(NO<sub>3</sub>)<sub>2</sub>.6H<sub>2</sub>O (Merck) were used. First 8 g zeolite was put at 600°C for 6 hours for calcinations. 13X granola was placed in a 250 ml Erlenmeyer flask and mixed with 50 ml of 1 molar solution of Al and Ni salts. Then shaken 400 OSC/min for 24 hours, filtered and washed by deionized water for 15 min and dried in 100 °C for 3 hours. The adsorption tests were carried out by Gas Adsorption Unit showed in Fig. 1.

### Adsorption test

The evaluation method for methane adsorption capacity

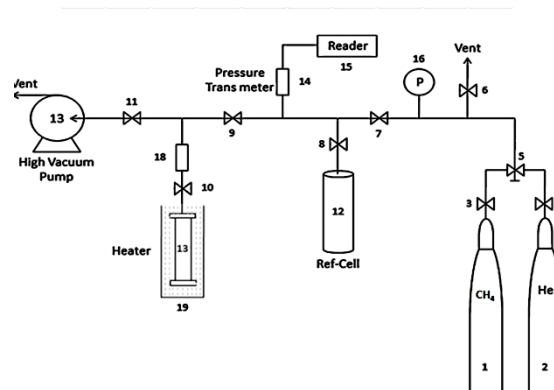

**Figure 1.** Gas adsorption unit

of zeolite was volumetric. 1 g zeolite used in each adsorption test. The adsorbent was loaded in the adsorption reactor (13) and heated to 300 °C and vacuumed for 1.5 hours to degas the zeolites. The adsorption tests were conducted at 1 to 11 bars pressure and at room temperature. A volume of gas was entered in a sealed vessel with specific pressure and this volume was exposed to the adsorbent and its pressure abatement was recorded, this reduction of gas pressure was related to some dead volume (including hollow space and connected tube) and some gas adsorption. Dead volumes evaluated by helium gas and the exact pressure decreased from the adsorption was calculated.

### Characterization

The porosity characteristic of the zeolite adsorbents were determined by N<sub>2</sub> adsorption-desorption experiment performed at 77 K on micromeritics model ASAP 2010 sorptometer. The specific surface area (S<sub>BET</sub>) was determined by Brunauer-Emmet-Teller (BET) method.

X-ray diffraction (XRD) was used to identify the crystal phase of the zeolite and identify the metals loaded on the zeolite. These experiments were carried out on Philips 1830 diffractometer equipped with Cu-K $\alpha$  radiation.

The amounts of metals loaded on the zeolites were determined by ICP (Inductive Coupled Plasma) method. This experiment was done by ICPS-7000 Ver 2 Shimadzu (Sequential Plasma Spectrometer).

## RESULT AND DISCUSSION

Figures 2 to 4 show that the methane adsorption capacities of those three zeolites were 13X-Al (III) > 13X-Na > 13X-Ni (II). The mechanical and electronic properties of ions affected the zeolite and methane adsorption capacity. Zeolite 13X-Al (III) had the largest pore size, surface area and adsorption capacity. One mole of Al ion could exchange with three moles of Na ions and

the adsorbent pores would be large with high adsorption capacity. When one mole of Ni (II) ion entered to the zeolite pores two moles of Na ion will exchange with it but the pores size would decrease because of the large size of the Ni (II) ion so the adsorption capacity of zeolite decreases. The hydrated ion size and charge capacity are two important parameters which affect the gas adsorption capacity of zeolites. The metal loaded on zeolite was about 19 to 20 mole percent or 0.002 g per 1 g adsorbent.

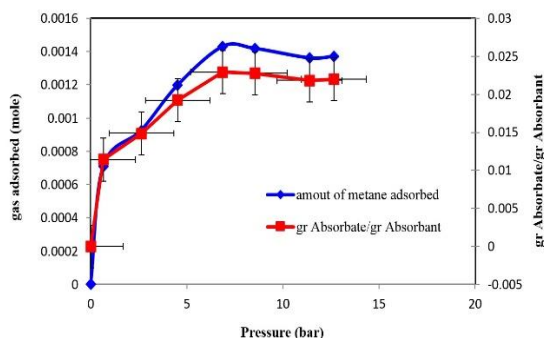

Figure 2. Experimental CH<sub>4</sub> adsorption isotherm in zeolite 13X-Na in 25 °C.

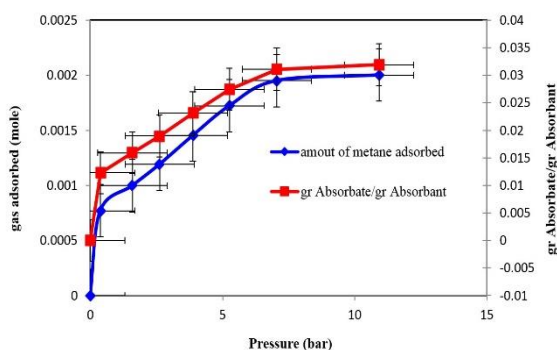

Figure 3. Experimental CH<sub>4</sub> adsorption isotherm in zeolite 13X-Ni(II) in 25 °C.

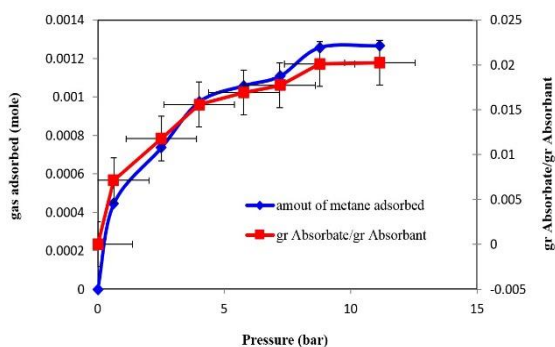

Figure 4. Experimental CH<sub>4</sub> adsorption isotherm in zeolite 13X-Al(III) in 25 °C

The XRD pattern showed no destruction for zeolites crystal structure in ion exchange experiment and the metals were successfully loaded into the zeolites pores. For Al<sup>3+</sup> exchanged zeolite, increase or decrease of the

picks in 2θ= 57.46, 52.42, 40.10 and 6.18 were due to the process of Al (III) ion in zeolite pores. For Ni<sup>2+</sup> exchanged zeolite, increase or decrease of the picks in 2θ= 57.5, 49.96, 26.74 and 23.38 were due to the process of Ni (II) ion in zeolite pores.

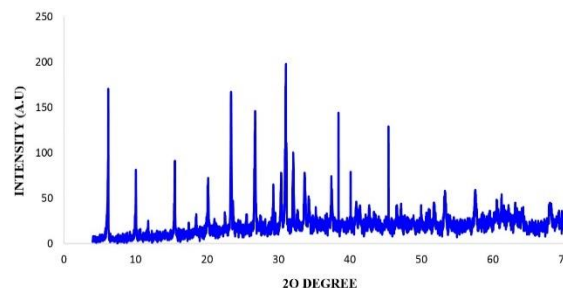

Figure 5. XRD pattern of zeolite 13X (Na exchanged)

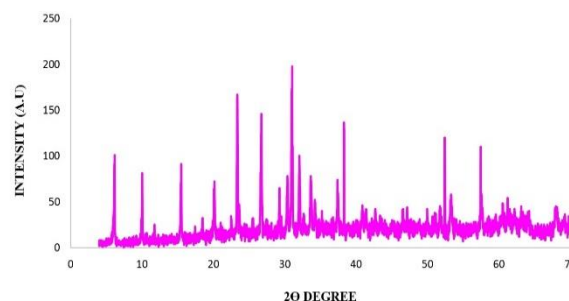

Figure 6. XRD pattern of zeolite 13X-Al (III)

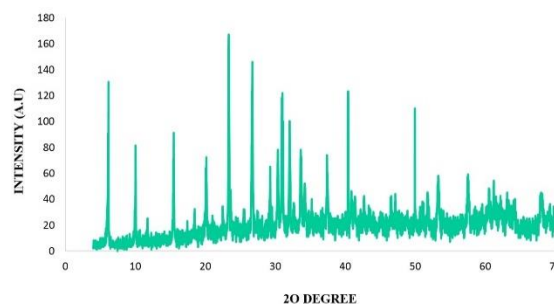

Figure 7. XRD pattern of zeolite 13X- Ni (II)

N<sub>2</sub> adsorption-desorption isotherm of the ion exchanged zeolites are presented in Table 1 and showed that Al exchanged zeolite had the largest surface area among those three types of zeolites.

TABLE 1. Physical properties of adsorbents.

Ion exchanged zeolites	BET area (m <sup>2</sup> /g)	Total pore volume (cm <sup>3</sup> /g)
Zeolite 13X-Na	537	0.22
Zeolite 13X-Ni (II)	486	0.11
Zeolite 13X-Al (III)	561	0.28

## CONCLUSION

Experimental adsorption of CH<sub>4</sub> at 25 °C and at pressure between 1 to 10 bars, showed that zeolite 13X-Al (III) had larger gas adsorption capacity compared to zeolite 13X-Ni (II) and zeolite 13X-Na. Al (III) ion size and charge can make zeolite pores more proper and increase the methane gas adsorption capacities. The amounts of methane that is adsorbed on these three zeolites are 1.4 mmol/g, 1.25 mmol/g and 2.1 mmol/g for zeolite 13X-Na, zeolite 13X-Ni and zeolite 13X-Al, respectively. It was concluded that use of the small ions with large charge capacities into zeolite pores of the modify zeolite enhanced the gas adsorption capacity.

## Acknowledgements

The authors are thankful to Research Council of Iran University of Science and Technology (Tehran) and Iran National Science Foundation (INSF) for financial support.

## REFERENCES

- Maljanen, M., P. Yli-Pirilä, J. Hytönen, J. Joutsensaari and P.J. Martikainen, 2013. Acidic northern soils as sources of atmospheric nitrous acid (HONO). *Soil Biology and Biochemistry*, 67: 94-97.
- Wuebbles, D.J. and K. Hayhoe, 2002. Atmospheric methane and global change. *Earth-Science Reviews*, 57(3): 177-210.
- Donner, L. and V. Ramanathan, 1980. Methane and Nitrous Oxide: Their Effects on the Terrestrial Climate. *Journal of the Atmospheric Sciences*, 37(1): 119-124.
- Ferch, H., 1980. Zeolites and clay minerals as sorbents and molecular sieves. Von R. M. Barrer. Academic Press, London – New York 1978. 1. Aufl., VII, 497 S., zahlr. Abb. u. Tab., Ln., \$ 52.50. *Chemie Ingenieur Technik*, 52(4): 366-366.
- Okumura, K., S. Matsumoto, N. Nishiaki and M. Niwa, 2003. Support effect of zeolite on the methane combustion activity of palladium. *Applied Catalysis B: Environmental*, 40(2): 151-159.
- Chatterjee, A. and F. Mizukami, 2004. Location and role of exchangeable cations in zeolite catalysis: a first principle study. *Chemical Physics Letters*, 385(1-2): 20-24.
- Hui, K., C. Chao, C. Kwong and M. Wan, 2008. Use of multi-transition-metal-ion-exchanged zeolite 13X catalysts in methane emissions abatement. *Combustion and Flame*, 153(1): 119-129.
- Mukainakano, Y., K. Yoshida, S. Kado, K. Okumura, K. Kunitomi and K. Tomishige, 2008. Catalytic performance and characterization of Pt-Ni bimetallic catalysts for oxidative steam reforming of methane. *Chemical Engineering Science*, 63(20): 4891-4901.
- Khalili, S., A.A. Ghoreyshi and M. Jahanshahi, 2012. CO Separation from Syngas by Multiwall Carbon Nanotube 2. adsorption, 2: 2.
- Miyawaki, J., T. Kanda, T. Suzuki, T. Okui, Y. Maeda and K. Kaneko, 1998. Macroscopic evidence of enhanced formation of methane nanohydrates in hydrophobic nanopores. *The Journal of Physical Chemistry B*, 102(12): 2187-2192.
- Cook, T.L., C. Komodromos, D.F. Quinn and S. Ragan, *Chapter 9 - Adsorbent Storage for Natural Gas Vehicles*, in *Carbon Materials for Advanced Technologies*, T.D. Burchell, Editor 1999, Elsevier Science Ltd: Oxford. p. 269-302.
- Himeno, S., T. Komatsu and S. Fujita, 2005. High-Pressure Adsorption Equilibria of Methane and Carbon Dioxide on Several Activated Carbons. *Journal of Chemical & Engineering Data*, 50(2): 369-376.
- Xu, X., C. Song, B.G. Miller and A.W. Scaroni, 2005. Influence of moisture on CO<sub>2</sub> separation from gas mixture by a nanoporous adsorbent based on polyethylenimine-modified molecular sieve MCM-41. *Industrial & engineering chemistry research*, 44(21): 8113-8119.
- Anbia, M. and V. Hoseini, 2012. Development of MWCNT@MIL-101 hybrid composite with enhanced adsorption capacity for carbon dioxide. *Chemical Engineering Journal*, 191: 326-330.
- Anbia, M., V. Hoseini and S. Sheykhi, 2012. Sorption of methane, hydrogen and carbon dioxide on metal-organic framework, iron terephthalate (MOF-235). *Journal of Industrial and Engineering Chemistry*, 18(3): 1149-1152.
- Dlugokencky, E.J., L.P. Steele, P.M. Lang and K.A. Masarie, 1994. The growth rate and distribution of atmospheric methane. *Journal of Geophysical Research: Atmospheres*, 99(D8): 17021-17043.
- Ruthven, D.M., *Principles of adsorption and adsorption processes* 1984: John Wiley & Sons.
- Figueiredo, H. and C. Quintelas, 2014. Tailored zeolites for the removal of metal oxyanions: Overcoming intrinsic limitations of zeolites. *Journal of Hazardous Materials*, 274: 287-299.
- Yu, H., Y. Lv, K. Ma, C. Wang, Z. Xue, Y. Zhao, Y. Deng, Y. Dai and D. Zhao, 2014. Synthesis of core-shell structured zeolite-A@ mesoporous silica composites for butyraldehyde adsorption. *Journal of colloid and interface science*, 428: 251-256.
- Zhang, J., N. Burke, S. Zhang, K. Liu and M. Pervukhina, 2014. Thermodynamic analysis of molecular simulations of CO<sub>2</sub> and CH<sub>4</sub> adsorption in FAU zeolites. *Chemical Engineering Science*, 113: 54-61.
- García-Trenco, A., S. Valencia and A. Martínez, 2013. The impact of zeolite pore structure on the catalytic behavior of CuZnAl/zeolite hybrid catalysts for the direct DME synthesis. *Applied Catalysis A: General*, 468: 102-111.
- Su, J., E. Kapaca, L. Liu, V. Georgieva, W. Wan, J. Sun, V. Valtchev, S. Hovmöller and X. Zou, 2014. Structure analysis of zeolites by rotation electron diffraction (RED). *Microporous and Mesoporous Materials*, 189: 115-125.
- Blakeman, P.G., E.M. Burkholder, H.-Y. Chen, J.E. Collier, J.M. Fedeyko, H. Jobson and R.R. Rajaram, 2014. The role of pore size on the thermal stability of zeolite supported Cu SCR catalysts. *Catalysis Today*, 231:56-63.
- Shao, H., Y. Li, X. Gao, C. Cao, Y. Tao, J. Lin and T. Jiang, 2014. Microporous zeolite supported Cr (acac)<sub>3</sub>/PNP catalysts for ethylene tetramerization: Influence of supported patterns and confinement on reaction performance. *Journal of Molecular Catalysis A: Chemical*, 390: 152-158.
- Hamidzadeh, M., A. Tarlani and M. Ghassemzadeh, 2015, *Iranica Journal of Energy & Environment*, 6(4): 274-281.
- Tebal, N., *Leachate Pollutants Adsorption Using Potassium Hydroxide and Surfactant Modified Bentonite for Possible Use as Slow Release Fertiliser*.

---

Persian Abstract

---

DOI: 10.5829/idosi.ijee.2016.07.03.02

**چکیده**

در این مطالعه، زئولیت نانو ساختار 13X به عنوان جاذب برای جذب گاز متان استفاده شده است. یون نیکل و آلومینیوم برای اصلاح حفرات زئولیت مورد استفاده قرار گرفت و ظرفیت جذب گاز متان در دمای اتاق و فشار بین یک تا دوازده بار اندازه گیری شده است. ویژگی های ساختاری زئولیت با روش های پراش اشعه ایکس (XRD) و آنالیز جذب و واجذب نیتروژن شناسایی شده است. از تکنیک پلاسمای جفت شده القایی (ICP) برای تعیین مقدار فلزات قرارگرفته بر روی زئولیت استفاده شده است.

---