

# Performance Analysis of UFMC and its Comparison with CP-OFDM

Sadhana Thiyagarajan<sup>1</sup>, Soundharya Veerappan<sup>1</sup>

<sup>1</sup>(Electronics and Communication Engineering, Periyar Maniammai Institute of Science and Technology, Vallam, Thanjavur, Tamilnadu, India.)

## Abstract:

Cyclic Prefix Orthogonal Frequency Division Multiplexing (CP-OFDM) is used in 4G communication systems. There are problems in 4G Waveform such as out of band emission and lower spectral efficiency which forces to explore new waveforms for Fifth Generation (5G). Universal Filtered Multi-Carrier (UFMC) is one such air interface which is analysed in this work and compared with CP-OFDM highlighting the merits of the candidate modulation scheme for 5G communication systems. This work presents the comparison UFMC and CP-OFDM on the basis of Peak to Average Power Ratio (PAPR) and Power Spectral Density (PSD) and analyse the performance of UFMC in Additive White Gaussian Noise (AWGN) channel using MATLAB. It is found that 40 dB reduction in out-of-band emission is seen in UFMC when compared to CP-OFDM with negligible increase in PAPR.

*Keywords* — UFMC, OFDM, PAPR, PSD, AWGN.

## I.INTRODUCTION

To support the next generation wireless communication system a new waveform candidate is required with higher data rates, lesser interference, better spectral efficiency, lower PAPR [1]. OFDM is the desired multi carrier modulation technique, for 4G communication systems, i.e Long Term Evaluation (LTE) and Wi-Fi comes under 4G communication. The advantages of OFDM are robustness to channel delays (high rate series data conversion to low rate parallel data conversion), single tap frequency domain equalization and effective implementation. It supports high transmission data rates and requires highly synchronized system. The additional of cyclic prefix leads to poor spectral efficiency [2-4]. So, to overcome this disadvantage, new modulation technique have been proposed i.e. the UFMC. Universal Filtered Multi Carrier is a attractive multi carrier having the advantages of CP-OFDM. It is utilized on sub band blocks i.e group of sub carriers. It groups sub carrier to sub-bands, which are then filtered individually as compared with single sub carrier. The filter parameters and number of carriers

remains same in each sub band to prevent aliasing [5,6].

## II.OBJECTIVE

The main objective of this paper is,

1. To study the suitability of present 4G waveform for new applications
2. To perform the comparative studies of various 5G waveform available in literature.
3. To study in depth about the UFMC Transceiver using MATLAB.
4. To compare the PAPR (Peak to Average Power Ratio) of cyclic prefix OFDM and UFMC using MATLAB.
5. To simulate the performance analysis of UFMC in AWGN channel using MATLAB.

## III.LIMITATION OF CP-OFDM

The major disadvantages of OFDM is absence of Asynchronous transmission. If the transmission is Asynchronous then the large overhead synchronization signalling will be avoided. Second the orthogonality among subcarriers cannot be maintained in OFDM. The orthogonality in OFDM

is based on the perfect synchronization carriers of transmitter and receiver. Third one is Out Of Band emission(OOB) in OFDM is very high. This Out Of Band emission will affect the adjacent carriers [7]. Finally, Synchronization in OFDM causes extra power consumption. So due to these drawbacks researchers looking forward for an alternate waveform which overcome the weaker aspects of CP-OFDM.

#### IV.UFMC TRANSCEIVER

To overcome the drawbacks of OFDM we should find a new waveform candidate in 5G physical layer. That new waveform should achieve asynchronous transmission, better spectral efficiency, low Out Of Band emission and low latency. But at the same time it must posses the easily tunable sub carriers. In this situation some new waveform available with less complex design as well as more attracted by the industries and researchers, i.e UFMC .

Universal Filtered Multi-carrier(UFMC) is a novel candidate waveform for future wireless systems. It is also known as Unified Filtered OFDM [6,7].

In the UFMC system the complex symbols of user  $K$  are generated from the base band modulator. These complex symbols are given as input to IDFT spreader and conversion of parallel to serial stream takes place to make a block of streams. Then the stream will be given to the filter with length of  $L$ . The filtered output of each blocks are added and then given to the baseband to RF section.

Finally the noise is added to the channel. The block diagram of transmitter and receiver chain will be expressed below.

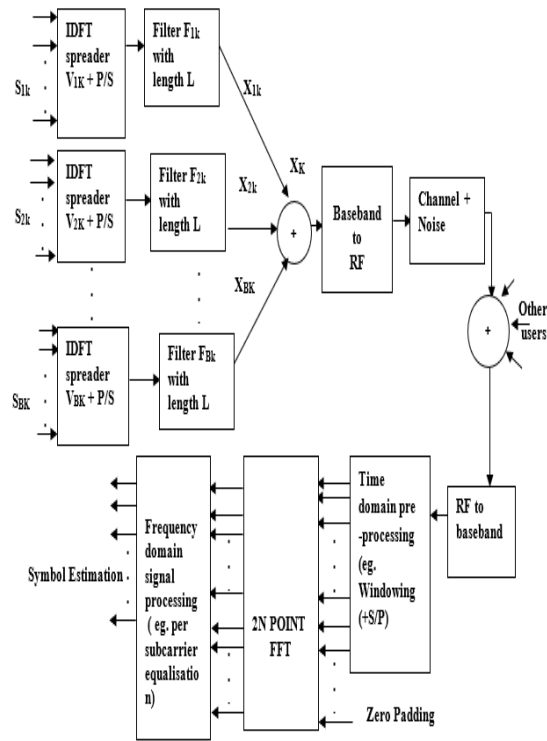

Figure 1: UFMC Transceiver architecture

In the receiver section, after RF to baseband link section the signal will be passing through the domain pre-processing window. In this window the interference is suppressed. After this process the signal will be converted to  $2N$  point streams. Those streams are parallel streams and here  $N$  is defined as number of sub carriers. The frequency domain symbol processing block is also known as symbol demapper. Here the symbol demapping process takes place. The demodulator used here is QPSK demodulator which is used to retrieve the data bits from the received symbols.

#### V.FILTERING IN UFMC

The filter used in UFMC is Dolph–Chebyshev Filter. It is of length  $L$ . The length of the filter depends upon the size of the sub-band. The Dolph–Chebyshev Filter minimizes the Chebyshev norm of the side lobes for a given main lobe. The filter

length is implemented using the built-in functions of the MATLAB and shown below

```
>> L = 74; r = 40;
>> w = chebwin(L,r);
>> wvtool(w)
```

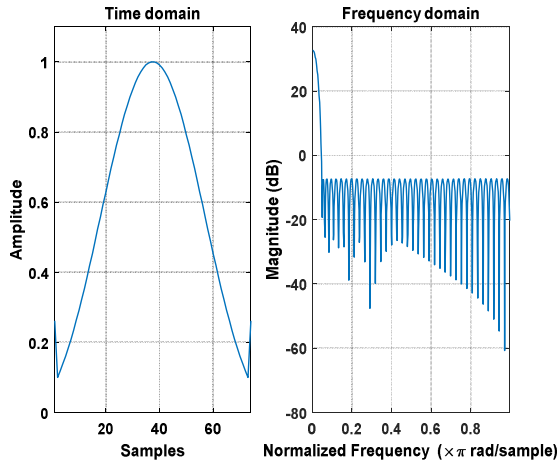

Figure 2: Time and frequency domain response of the filter

The Dolph-Chebyshev window is constructed in the frequency domain by taking samples of the window's Fourier transform. Dolph Chebyshev window is used in spectral analysis and FIR filtering.

### VI. ANALYSIS OF CP-OFDM AND UFMC

#### a) Power Spectral Density (PSD):

Power Spectral Density helps to display the strength of the energy variation as a function. It shows, at which point the variations of frequency is weaker. The PSD computation is done through FFT method. Integration of PSD provides the energy of the specific frequency range.

$$PSD = \frac{Energy [W]}{Frequency [Hz]} \quad (1)$$

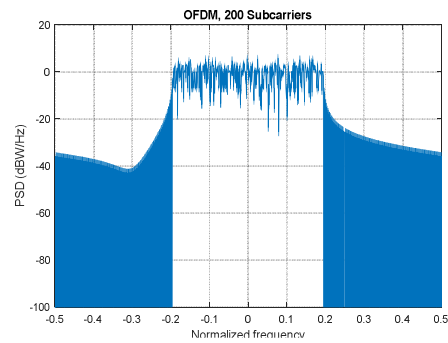

Figure 3: Frequency response of CP-OFDM

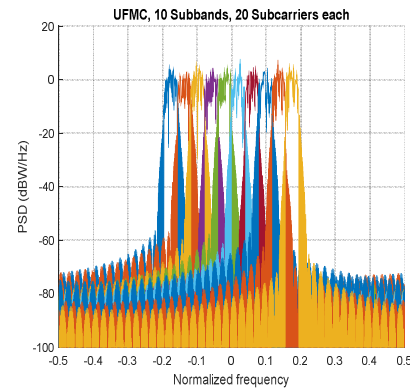

Figure 4: Frequency response of UFMC

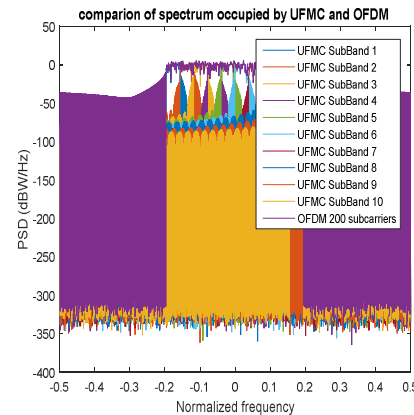

Figure 5: Comparison of spectrum occupied by UFMC and CP-OFDM

- From the above figure 3 & 4, it is found that CP-OFDM spectrum in the out of band is **-40 dB/MHz** whereas for UFMC it is of **-80 dB/MHz**.
- Therefore spectrum leakage will be less felt when we use UFMC.

TABLE I  
DESIGN PARAMETERS

SYSTEM PARAMETER	VALUES
FFT Length	1024
Bits Per Symbol	2
Filter Length	74
Filter Atten Db	40

b) Peak To Average Power Ratio

The highest peak to average power ratio is the main disadvantage of the multicarrier modulation techniques the input data stream is subdivided into many sub streams .This sub streams are called sub carriers. The subcarriers are modulated (Independently) at different carrier frequency and it produces a high PAPR for transmission purpose added up simultaneously. The peak power of a signal is produced when N number of signals are added in the same phase [8,9]. The peak power of a signal is produced when N times the average power of the signal. So the PAPR value is very high in the multicarrier signals .The Peak to Average Power Ratio is expressed as

$$PAPR = \frac{\max\{|X(t)|^2\}}{E\{|X(t)|^2\}} \quad (2)$$

Here, |X(t)| is the amplitude of the X(t) and E is the expectation of the signal.

TABLE 2  
PAPR COMPARISON

MULTI CARRIER MODULATION	PAPR (dB)
UFMC	7.5542 dB
CP-OFDM	6.9638 dB

- From the table 2 it is clear that the Peak-to-Average –Power –Ratio (PAPR) for UFMC is high but it is negligible when compared to the increase.
- The PAPR variation between the UFMC and OFDM closer to each other. That variation is not a big deal.

**VILSOFTWARE ARCHITECTURE**

The software architecture is the next important part of this paper in which descriptions of various modules are shown.

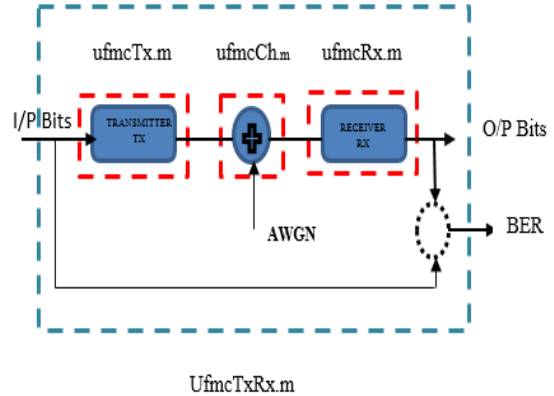

Figure 6: Block diagram of Software Architecture

The system under simulation is shown in Figure 6. In this figure the transmitter, channel and receiver is implemented as an m-file .The channel is the addition of Additive Gaussian White Noise variance is varied with the target SNR ratio.

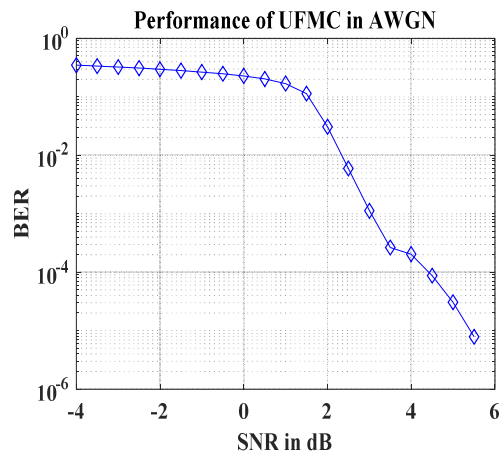

Figure 7: Bit error Rate of UFMC under AWGN channel

Figure 7 shows the variation of bit errors with respect to the SNR in dB. The above result is only for AWGN channel.

## VIII. ADVANTAGES AND DISADVANTAGES

- In UFMC waveform, the asynchronous multi-user performance was enhanced by the pulse shaping function.
- UFMC retains backward compatibility also with the algorithms of OFDM.
- Low complexity and noise enhancement is the disadvantage of UFMC.
- UFMC has high spectral efficiency [10].

## IX. CONCLUSION AND FUTURE SCOPE

UFMC is multicarrier modulation technique is used to suppress the ICI and in order to increase the performance of the system. The filtering process is used to reduce the Out Of Band sidelobe leakage it provides a better spectrum operation when compared to OFDM and also provides a better ICI robustness.

In this work, we comparatively analyse the frequency response of CP-OFDM and UFMC and Performance analysis of UFMC in AWGN channel. From this, we concluded that the UFMC has high Peak to Average Power Ratio (PAPR) and low Power Spectral Density (PSD) when compared to CP-OFDM.

So we suggest that UFMC is quite suitable for future generation. UFMC also has the limitation of high PAPR reduction in UFMC it will be more reliable and efficient for next generation wireless communication.

## X. REFERENCES

1. Robin Gerzaguet et al. "The 5G candidate waveform race: a comparison of complexity and performance", *EURASIP Journal on Wireless Communications and Networking* 2017:13
2. 5G Waveform & Multiple Access Techniques, <https://www.qualcomm.com/.../5g-research-on-waveform-and-multiple-access-techniq...>, November 4, 2015
3. X. Zhang, L. Chen, J. Qiu and J. Abdoli, "On the Waveform for 5G," in *IEEE Communications Magazine*, vol. 54, no. 11, pp. 74-80, November, 2016.

4. Y. Liu et al., "Waveform Design for 5G Networks: Analysis and Comparison," in *IEEE Access*, vol. 5, pp. 19282-19292, 2017.
5. X. Zhang, M. Jia, L. Chen, J. Ma and J. Qiu, "Filtered-OFDM - Enabler for Flexible Waveform in the 5th Generation Cellular Networks," *2015 IEEE Global Communications Conference (GLOBECOM), San Diego, CA, 2015*, pp. 1-6.
6. Sathiyapriya N.S, "Implementation and Study of Universal Filtered Multi Carrier under Carrier Frequency Offset For 5 G", *IPASJ International Journal of Electronics & Communication (IJEC)*, Volume 4, Issue 4, April 2016.
7. Pooja Rani, Silki Baghla, Dr.Himanshu Monga, "Performance Evaluation of Multi-carrier Modulation Techniques for Next Generation Wireless Systems", *International Journal of Advanced Research in Computer Science*, Volume 8, No. 5, May – June 2017.
8. P. Nagarani, Ch.Shanthi Rani, "UFMC: The 5G modulation technique" *Computational Intelligence and Computing Research (ICIC)*, *IEEE International Conference on Chennai, India, 2016*.
9. K.Krishna Kishore, P. Rajesh Umar, "Comprehensive Analysis of UFMC with OFDM", *Indian Journal of Science & Technology (IJST)*, Volume 10, Issue 17, May 2017.
10. Charleston Dale M. Ambatali, Joel Joseph S. Marciano, "Performance evaluation of the UFMC scheme under various transmission impairments", *IEEE Communication, Networks and Satellite (COMNETSAT)*, Surabaya, Indonesia, 2016.