

EFFECT OF ALUMINIUM SULPHATE AGING ON COAGULATION PROCESS FOR THE PRUT RIVER WATER TREATMENT

Larisa Postolachi*, Vasile Rusu, Tudor Lupascu

Institute of Chemistry of Academy of Sciences of Moldova, 3 Academiei str., Chisinau MD-2028, Republic of Moldova
*e-mail: larisa.postolachi@gmail.com; phone: (373 22) 73 97 31; fax: (373 22) 73 99 54

Abstract. Aluminium sulphate is one of the most widely used coagulants for water treatment and has been proven to be an effective coagulant for the removal of certain contaminants, turbidity and colour. Aluminium sulphate used during the coagulation process is hydrolyzed in the water, forming polynuclear complexes. Aged aluminium solutions show different coagulation behaviour than that of freshly prepared solutions. The aim of presented research was to highlight the influence of the *aging* of aluminium sulphate solution on the turbidity removal from water. Obtained results reveal that using of optimal *aging* solution of coagulant improves the coagulation process.

Keywords: coagulation, *Jar-test*, aluminium sulphate, *aging*.

Received: January 2016/ Revised final: February 2016/ Accepted: March 2016

Introduction

The quality of river or reservoir water is commonly characterized by the content of suspended solids, colloidal particles, natural organic matter and other soluble, mostly inorganic compounds, present in different concentrations. Therefore, when the river or reservoir water is intended for human consumption, an appropriate treatment process is usually considered as necessary to meet the respective drinking water standards. One of the most important steps during the conventional treatment process is coagulation/flocculation [1].

Coagulation is a common process in water treatment for destabilizing dissolved and colloid impurities and for transforming small particles into larger aggregates (flocs) which can be removed from the water in subsequent clarification/filtration processes [2-4].

The coagulation process consists of three sequential steps: coagulant formation, colloid/particle destabilisation, and particle aggregation. Coagulant formation and colloid/particle destabilisation are promoted in a rapid-mixing stage where treatment chemicals are added and dispersed throughout the water to be treated. Particle aggregation (floc formation) is then promoted in a flocculation stage where inter-particles collisions create large floc particles amenable to separation from the treated water [3].

Aluminium sulphate is one of the most widely used coagulants for water treatment and has been proven to be an effective coagulant for the removal of certain contaminants, turbidity and colour [5-7]. When dosed into water the aluminium ions hydrolyse rapidly and in an uncontrolled manner, to form a range of metal hydrolysis species [3].

Hydrolysis products may be monomeric or polymeric hydroxyl complexes [8]. Most of them, such as $\text{Al}(\text{OH})_2^+$, $\text{Al}(\text{OH})_2^+$, $\text{Al}_2(\text{OH})_2^{4+}$, $\text{Al}_3(\text{OH})_2^{5+}$ and $\text{Al}_{13}\text{O}_4(\text{OH})_{24}^{7+}$ (or “ Al_{13} ”), are positively charged and can interact strongly with the negative colloids, resulting in destabilization and coagulation [1].

The aluminium species distribution in coagulant solutions can be influenced by many parameters [5]. A range of factors such as the nature of the water, the coagulation pH and the dose of coagulant together influence the range of species formed and subsequently, the treatment performance [3]. The pH value of the medium is of the primary importance in the establishing the mean charge of the hydrolysis products and, consequently, is of significance for the rate of coagulation (Scheme 1). The pH of aluminium solutions decreases during *aging* and in the speciality literature there are shown that *aged* aluminium solutions give entirely different coagulation values than *unaged* aluminium solutions [9].

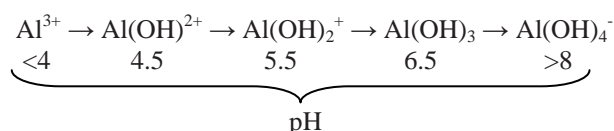

Scheme 1. Hydrolysis products of aluminium in relation to pH value [1].

The main water supply sources of the Republic of Moldova are the Dniester River, which covers about 54% of the total water quantity, the Prut River – 16%, other sources of surface water – 7% and groundwater sources – 23% [10]. The water quality from water supply sources often does not correspond to the drinking water criteria, because of the high turbidity, the high content bacteria or dangerous dissolved substances. Therefore, before to be consumed the natural water would be processed.

The main stages, at the Water Treatment Plant, Municipal Company “Apa-Canal”, the town Ungheni (Republic of Moldova), applied in the potabilization technologies include also the coagulation of particulate materials from the Prut River water. In previous study [11], in order to optimize the process of coagulation there were studied the several factors, namely the influence of mixing speed and of concentration of coagulant added in the process of coagulation. The aim of presented research was to highlight the influence of the *aging* of aluminium sulphate solution on the turbidity removal from water.

Experimental

Laboratory coagulation tests were performed on two different types of raw water:

1. Model solution. In order to simulate the presence of suspended solids (turbidity) in tap water there were dispersed the bottom sediments. The initial turbidity of model solution using during coagulation tests was ranged in the limits 32 and 39 NTU (nephelometric turbidity units).

2. River (raw) water samples were taken from the Prut River at the Water Treatment Plant, Municipal Company “Apa-Canal”, the town Ungheni (Republic of Moldova). The coagulation process was studied on raw water with turbidity between 33 and 63 NTU.

In Table 1 there are presented the characteristics of initial samples used during coagulation process.

Table 1

Characteristics of the water samples, used for coagulation experiments.

Water type	pH	Temperature, °C	Turbidity, NTU
Model solution	7.87 ÷ 8.05	15.6 ÷ 18.5	32 ÷ 39
Prut River	7.82 ÷ 7.93	20.5 ÷ 24.7	33 ÷ 63

Coagulant

The aluminium sulphate ($\text{Al}_2(\text{SO}_4)_3 \cdot 18\text{H}_2\text{O}$, purchased from Sigma-Aldrich) was used as coagulant, the working solutions being of 10 and 25%. The coagulant doses used were as following: 3.7, 4.9 and 9.8 mg/L.

Aging process

All coagulant solutions were *aged* at room temperature and kept in the dark before coagulation experiments. During the entire *aging* period, samples were clear to the naked eye.

Jar-test procedures

Coagulation experiments were carried out using a *Jar-test* apparatus [12, 13]. The scheme of *Jar-tester* used for coagulation experiments is presented in Figure 1. The sample (800 mL of water) was dosed with the appropriate amount of coagulant. The suspensions were stirred rapidly at 500 rpm for 2 minutes during coagulant addition, followed by slow stirring at 120 rpm for 20 min. After mixing the samples have been left for settling of flocs. At the end of the settling period (20, 40 and 60 minutes), the supernatant is withdrawn for analyses.

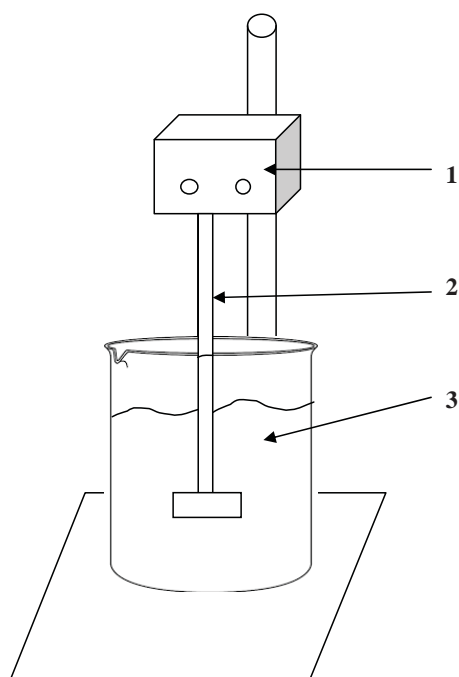

Figure 1. Scheme of *Jar-tester*, used for coagulation experiments.

1 – battery and control box, 2 – stirrer, 3 – jar.

Turbidity measurement

The turbidity of water samples has been determined according to World Health Organisation recommendations [14], using the UV/Vis spectrophotometer, Jenway model 6505.

The turbidity removal (R_T , %), which expresses the efficiency of the process, was calculated by Eq.(1) [15]:

$$R_T = \frac{T_i - T_r}{T_i} \cdot 100\% , \quad (1)$$

where: T_i – initial turbidity, NTU;

T_r – residual turbidity, NTU (the turbidity of supernatant after coagulation and settlement).

Results and discussion

The influence of coagulant aging time on coagulation process performed on model solution

The aged aluminium solutions show different coagulation behaviour than that of freshly prepared solutions [9]. The influence of aging time of the coagulant (coagulant concentrations of 10% and 25%) on the degree of turbidity removal (R_T , %) was carried out at different settling time (Figures 2 and 3). The Jar-tests were performed using different doses of coagulant, namely 3.7, 4.9 and 9.8 mg/L. The coagulation process was studied on model solution with turbidity between 32 and 39 NTU. The coagulant solutions were aged for 1-10 days (coagulant concentration of 10%) and 1-6 days (coagulant concentration of 25%).

The use of aged coagulant exhibits a better coagulation performance in comparison with unaged coagulant. It was established that for the coagulant solution of 10% the coagulation process in model solution pass off more efficiently in case of aged coagulant for 4-5 days, registering higher values of the degree of turbidity removal (Figure 2).

For coagulant solution of 25% the coagulation process in model solution pass off more efficiently at the addition of aged coagulant for period of 3-4 days (Figure 3), since the processes of aging are faster in the solutions with higher concentrations of hydroxyl ions [9].

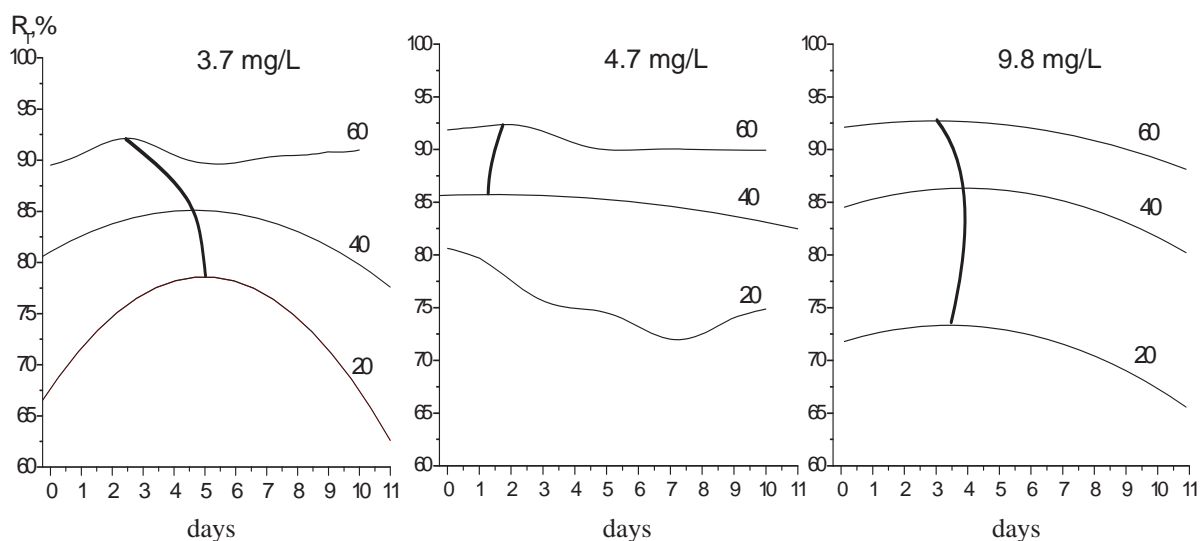

Figure 2. The influence of aging time of the coagulant solution (10%) on the degree of turbidity removal (R_T , %) of model solution.

Coagulant doses: 3.7, 4.9 and 9.8 mg/L.

Settling time: 20, 40 and 60 minutes.

The influence of coagulant aging time on coagulation process performed on natural water

During the coagulation process, there are two types of colloids: (i) those present in the water to be treated, and (ii) those formed by added coagulants [9].

The influence of coagulant aging time (coagulant concentrations of 10% and 25%) on turbidity removal was shown in Figures 4 and 5. The Jar-tests were performed on natural water (Prut River) with turbidity ranged in limits 33-63 UNT. The coagulant solutions were aged for 1-7 days (coagulant concentration of 10%) and 1-3 days (coagulant concentration of 25%).

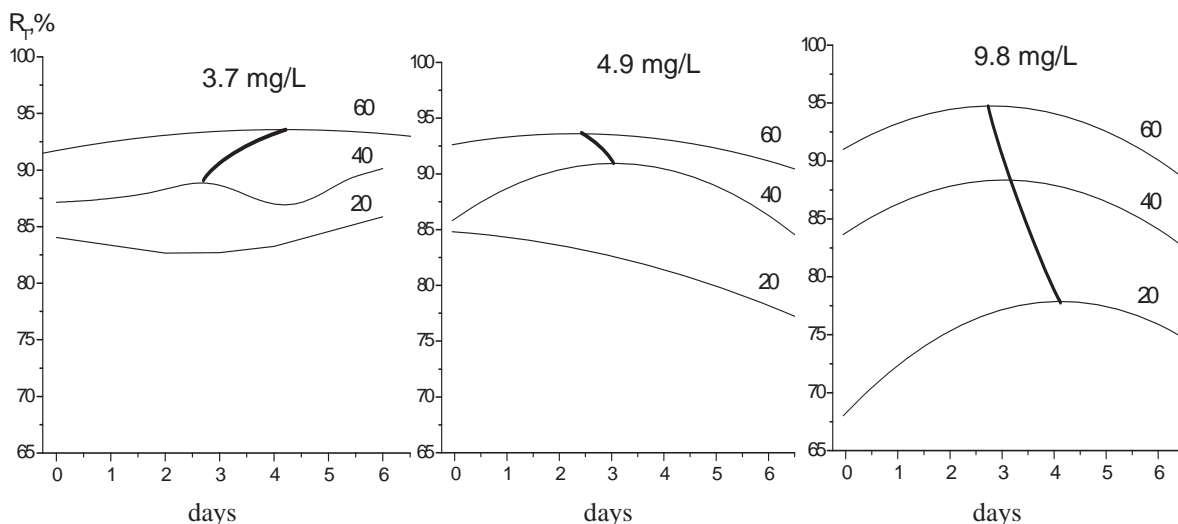

Figure 3. The influence of *aging* time of the coagulant solution (25%) on the degree of turbidity removal (R_t , %) of model solution. Coagulant doses: 3.7, 4.9 and 9.8 mg/L. Settling time: 20, 40 and 60 minutes.

The coagulation efficiency, for aluminium sulphate solution (10%), increased along with the increasing *aging* time, especially when the *aging* time exceeded 4 days. Thus, during *Jar-testing*, it was established that for coagulant concentration of 10% the coagulation process pass off more efficiently using the *aged* coagulant for 4-5 days, being recorded the values of turbidity removal in the range 90-98% (Figure 4).

The *aging* reactions are more rapid in solutions having higher hydroxide aluminium concentration, or at elevated temperatures [9]. On the basis of the results for coagulant concentration of 25%, it can be seen that the *aged* coagulant for 2 days is more effective for turbidity removal, registering the values of turbidity removal in the range 95-99% (Figure 5).

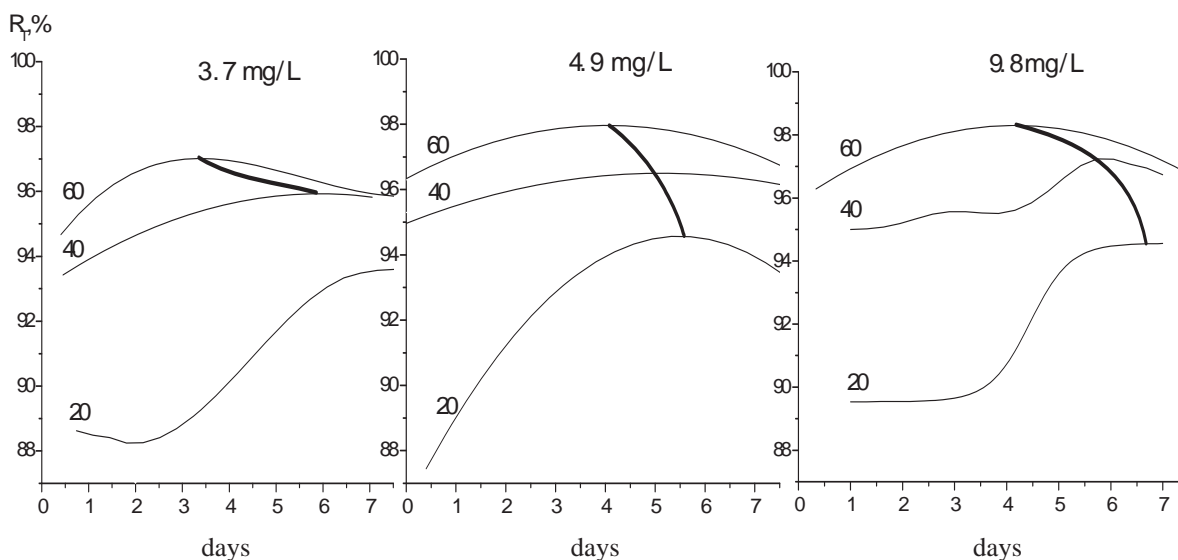

Figure 4. The influence of *aging* time of the coagulant solution (10%) on the degree of turbidity removal (R_t , %) of the Prut River water. Coagulant doses: 3.7, 4.9 and 9.8 mg/L. Settling time: 20, 40 and 60 minutes.

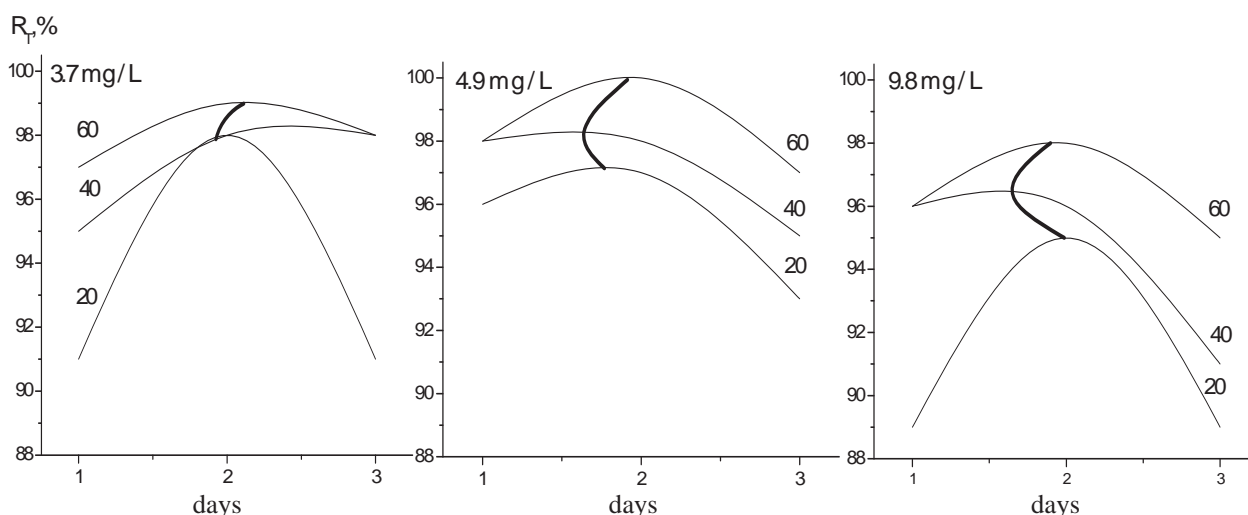

Figure 5. The influence of *aging* time of the coagulant solution (25%) on the degree of turbidity removal (R_r , %) of the Prut River water. Coagulant doses: 3.7, 4.9 and 9.8 mg/L. Settling time: 20, 40 and 60 minutes.

The variation of residual turbidity in the Prut River water during coagulation in function of settling time is presented in Table 1. The lowest value of residual turbidity in raw water is recorded after 60 minutes of settling, being in limits 0.4 – 1.7 UNT in case of aluminium sulphate solution of 10% and 0.3 – 1.6 UNT in case of aluminium sulphate solution of 25%. The recorded values of residual turbidity are less than 5 NTU, which framing in limits of the existing criteria for drinking water [16].

Table 2

Dynamics of residual turbidity (T_r) in the Prut River water during coagulation in function of settling time. Coagulant dose: 4.9 mg/L.

Aging time	Initial turbidity, NTU	T_r after 20 minutes of settling, NTU	T_r after 40 minutes of settling, NTU	T_r after 60 minutes of settling, NTU
Aluminium sulphate solution of 10%				
1 day aged	63	6.8	3.2	1.7
2 days aged	51	4.1	2.0	0.8
3 days aged	54	5.1	2.0	1.6
4 days aged	44	2.0	1.2	0.4
5 days aged	33	1.6	1.2	1.0
7 days aged	50	3.1	2.1	1.3
Aluminium sulphate solution of 25%				
1 day aged	63	2.5	1.3	1.3
2 days aged	51	1.6	0.8	0
3 days aged	54	4.0	2.4	1.6

Conclusions

The results presented in this study suggest that the using of optimal *aging* solution of coagulant improves the coagulation process. The coagulation process, performed on the Prut River, pass off more efficiently using the *aged* coagulant for 4-5 days in case of aluminium sulphate of 10% and the *aged* coagulant for 2 days in case of aluminium sulphate of 25%. The lowest value of residual turbidity in raw water is recorded after 60 minutes of settling. The recorded values of residual turbidity are less than 5 NTU, which framing in limits of the existing criteria for drinking water.

Acknowledgments

Thanks to deputy-director Ms. Natalia Bors for permission to perform this study at the Municipal Water Treatment Company “Apa-Canal” of the town Ungheni.

References

1. Zouboulis, A.; Traskas, G. Comparable evaluation of various commercially available aluminium-based coagulants for the treatment of surface water and for the post-treatment of urban wastewater. *Journal of Chemical Technology and Biotechnology*, 2005, 80, pp.1136–1147.
2. Gao, B.; Hahn, H.; Hoffmann, E. Evaluation of aluminum-silicate polymer composite as a coagulant for water treatment. *Water Research*, 2002, 36, pp. 3573–3581.
3. Jiang, J.-Q.; Graham, N. Pre-polymerised inorganic coagulants and phosphorus removal by coagulation - A review. *Water SA*, 1998, 24(3), pp. 237–244.
4. Zeng, Y.; Park, J. Characterization and coagulation performance of a novel inorganic polymer coagulant–Poly-zinc-silicate-sulfate. *Colloids and Surfaces A: Physicochemical and Engineering Aspects*, 2009, 334, pp. 147–154.
5. Zhang, P.; Hahn, H.; Hoffmann, E.; Zeng, G. Influence of some additives to aluminium species distribution in aluminium coagulants. *Chemosphere*, 2004, 57, pp. 1489–1494.
6. Shen, Y.-H.; Dempsey, B. Synthesis and speciation of polyaluminum chloride for water treatment. *Environment International*, 1998, 24(8), pp. 899–910.
7. Dolejs, P. Treatment of low alkalinity humic waters with partially neutralized aluminium sulphate. *Environmental Technology Letters*, 1989, 10, pp. 41–48.
8. Wu, Z.; Zhang, P.; Zeng, G.; Zhang, M.; Jiang, J. Humic acid removal from water with polyaluminum coagulants: effect of sulfate on aluminum polymerization. *Journal of Environmental Engineering*, 2012, 138(3), pp. 293–298.
9. Stumm, W.; Morgan, J. Chemical aspects of coagulation. *Journal of the American Water Works Association*, 1962, 54, pp. 971–992.
10. Children’s health and environment in the Republic of Moldova, Chisinau, 2010.
http://www.mediu.gov.md/images/documente/starea_mediului/rapoarte/nationale/p5_raport_parma_en.pdf.
11. Postolachi, L.; Rusu, V.; Lupascu, T.; Maftuleac A. Improvement of coagulation process for the Prut River water treatment using aluminum sulphate. *Chemistry Journal of Moldova*, 2015, 10(1), pp. 25–32.
12. Satterfield, Z. Jar Testing. *Technical Brief*, 2005, 5(1), pp. 1–4.
13. Pask, D. Jar Testing: Getting started on a low budget. *On Tap*, 1993, 2(2), pp. 4–6.
14. Madera, V.; Allen, H. E.; Minear, R. A., Eds. *Examination of Water for Pollution Control*, World Health Organization. Pergamon Press: Copenhagen, Denmark, 1982, 1st Ed., vol. 2, pp. 37–42.
15. Stefan, D.; Costache, C.; Ruxandu, V.; Balas, M.; Stefan, M. Comparative study on surface water treatment using aluminum sulphate and polyaluminum chlorides as coagulant reagents. *Environmental Engineering and Management Journal*, 2009, 8(4), pp. 859–863.
16. Governmental Decision no. 934 of 15 August 2007 regarding the establishment of automated information system “State Register of natural mineral and drinking waters and soft bottled drinks”. *Official Journal of the Republic of Moldova*, 24.08.2007, no. 131-135 (970). (in Romanian).
<http://lex.justice.md/viewdoc.php?action=view&view=doc&id=326557&lang=1>.