

Reduction of Heart Absorbed Dose in Cobalt- Therapy of Stomach Cancer

D. Rezaei-Ochbelagh ^{*a}, S. Salman-Nezhad^b

Article Authorship & Affiliation Details

Communication Date: July, 15, 2015

Acceptance Date: July. 05, 2015

DOI:

D. Rezaei-Ochbelagh,

**Department of Nuclear Engineering & Physics,
Amirkabir University of Technology, Tehran,
Iran**

Email:

S. Salman-Nezhad^b

Physics Department, University Of Mohaghegh Ardabili, Ardabil, Iran

Corresponding Author. D.REZAEI-OCHBELAGH

TEL.:+982164542260 ; FAX:+982164542262 .

E-Mail Address ddrezaey@yahoo.com

Key Words: Adult Phantom; Heart; absorbed dose;
cobalt unit; MCNP code.

To cite this article: D. Rezaei-Ochbelagh, S. Salman-Nezhad. *Reduction of heart absorbed dose in cobalt-therapy of stomach cancer [Online]. Journal Of Exercise Science And Physiotherapy, Vol. 11, No. 2, June 2015: 142-149.*

Abstract

The external photon beam radiotherapy should be carried out in a way to achieve an "as low as possible" a dose in healthy tissues surrounding the target. For the scope of protection against undue exposure to ionizing radiation it is necessary to determine radiation dose to specific body organs and tissues. Heart as a surrounding organ in stomach cancer radiotherapy, will be exposed to rays during this process. By considering its vital role in pumping blood to different tissues (about 2000 gallons per day), the insufficiency of exposure to gamma rays may show itself sensibly. A collimator has been suggested to reduce absorbed dose in heart about 36% and a reduction of about 85% in heart zone.

Introduction

Although it has been generally accepted since the mid-1960s that radiation doses of around 40 Gy or more can cause heart disease, in recent years it has been observed evidence of an increased risk of radiation-induced heart disease at doses below 5 Gy [1].

Fig. 1 shows the excess relative risk versus colon dose. It must be mentioned that the most important study has considered mortality in the survivors of the atomic bombings of Hiroshima and Nagasaki.

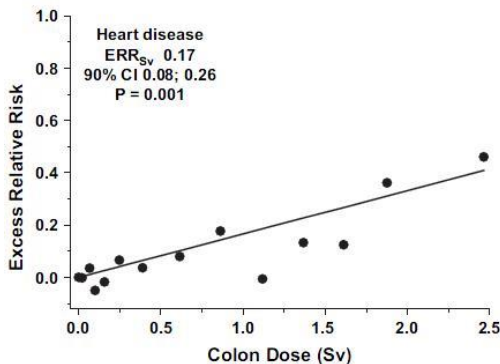

Fig.1. Risk of death from heart disease in the Life Span Study cohort of survivors of the atomic bombings of Hiroshima and Nagasaki.

The graph shows the excess relative risk (i.e. the proportionate increase in risk) versus colon dose in Sievert (Sv). Doses to other organs were similar to the colon dose in this population. The radiation was mostly from gamma-rays with only a small neutron component, so 1 Sv - 1 Gy [1].

The individuals in this study received whole-body uniform doses in the range of 4 Sv. The dose rate was mostly delivered by gamma-rays. Among the non-cancer diseases considered, the most common specific cause of death was heart disease, with 4477 deaths. Further analyses, specifically of heart disease, revealed a dose-response relationship that was highly significant statistically and appeared linear with no threshold, with each additional Sv of radiation increasing the mortality rate by a factor of 0.17[1].

A long-standing problem in radiotherapy treatment planning has been calculation of dose distribution in different tissues of

body when it is radiated with an external gamma source. Radiotherapy with external photon beam should be carried out in a way to achieve "as low as possible" a dose in healthy tissues surrounding the target [2, 3]. For the scope of protection against undue exposure to ionizing radiation it is necessary to determine absorbed dose in specific body organs and tissues. It is impossible to produce an analytic expression to describe the transport of particles through the body due to the multitude and the complexity of its interactions. Monte Carlo simulations are needed accurately to solve this kind of complexity [4]. One of these specific organs can be heart as a vital organ of body. As it is impossible directly to determine the absorbed dose by heart, in this study we have presented a simplified model for Co-60 radiotherapy machine and used Monte Carlo simulation of trunk according for an adult phantom developed by Fisher and Snyder [5]. None the less, we experimentally used TLD chips to measure absorbed dose in heart zone of a patient that radiated by Co-60 source because of stomach cancer disease. Experimental results show reduction absorbed dose in heart. In addition a model collimator has been designed to reduce absorbed dose in heart. Finally, by using MCNP code [6], we have calculated absorbed dose in different parts of heart before and after applying the designed collimator. The aim of this study is to quantify absorbed dose in heart when a phantom is irradiated by Co-60 machine in order to therapy stomach cancers and to investigate the influence of

using collimator to reduce cardiac dose and absorbed dose in body.

Materials and methods

The Monte Carlo method is a powerful tool for simulating gamma-ray interactions that occur in medical devices. In this work, MCNP code based on the Monte Carlo method has been applied to simulate particle transport in a co-60 radiotherapy unit. In Monte Carlo method, a detailed physics treatment including photoelectric effect with fluorescence production, incoherent scattering with form factors and pair production has been considered. In input file of MCNP code, the trunk of a human body has been modeled using the phantom developed by Fisher and Snyder (Fig. 2). Our study has focused on the absorbed dose by different parts of heart while the stomach has undergone the radiation of Co-60 radiotherapy unit. In this study we are investigating ways to achieve a reduction in the absorbed dose by heart as a vital organ.

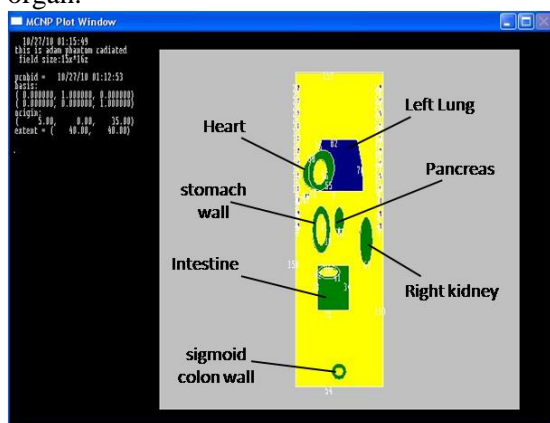

Fig.2. Trunk according to the Fisher-Snyder developed phantom plotted by MCNP code

Monte Carlo simulation of a cone collimator design

The Cobalt-60 machine is a cancer therapy unit where ^{60}Co emits photon as a gamma source. The ^{60}Co is produced by irradiating ordinary stable ^{59}Co with neutrons in a reactor. The decay of each atom of ^{60}Co to ^{60}Ni generates two photons of gamma radiation with energies of 1.17 and 1.33 MeV and a beta with maximum energy of 0.32MeV.

The gamma rays constitute the useful beam for treatment of cancers inside the body and the β particles are absorbed in the cobalt container capsule [7]. Tungsten with a density of 18.30 gr/cm^3 is used as the surrounding shield material. A device is constructed to obtain controllable therapeutic gamma beam. The structure of device is simulated by MCNP code. Figs. 3 and 4 that extracted from output file of MCNP code show the simplified model of the device.

The diagram of the simplified model of the device is shown in Figs. 3 to 5. In order to simulate a cobalt unit model two main components, the source capsule and the collimator system, have been studied. The capsule contains cobalt pellets and it has cylinder geometry with a radius of 7.4 mm and a thickness of 2.35 mm [8].

The collimator is simplified to obtain different field sizes at a source–surface distance (SSD) equal to 80 cm. As seen in Fig. 3, a sphere has surrounded the source to shield the isotropic source and a plate has cut the sphere at distance of 45 cm from the source face, as the collimator

opening allows gamma photons to pass [8]. Fig. 4 represents the simplified model of machine geometry .

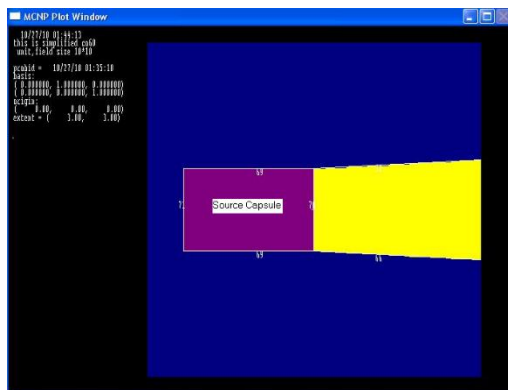

Fig.3. the source capsule is a cylinder with a radius of 7.4 mm and a thickness of 2.35 mm which is surrounded by the lead sphere, as the opening of the collimator is free for gamma photons to pass.



Fig.4. cobalt source is nearly located at the center of the lead sphere. There is a specific collimator opening in order to make a field size of $10 \times 10 \text{ cm}^2$ at 80 cm SSD.

Accuracy of simulated model

In order to check accuracy of the simulated model, a water phantom cube has been considered against gamma photons with a field size of $10 \times 10 \text{ cm}^2$ at 80 cm SSD (Fig. 5).

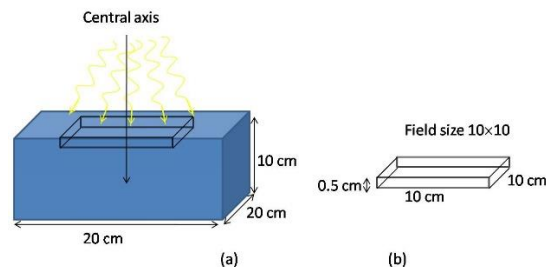

Fig.5. Schematic diagram of a) water phantom and b) a cell defined inside water to calculate absorbed dose rate in a depth of 0.5 cm by MCNP code.

Dose rate measurement

Dose rate of cobalt-60 gamma photons in a depth of 0.5 cm in mentioned water phantom for radiotherapy unit of model Phoenix has been measured by an ionizing chamber that made by SAINT-GOBAIN Crystals & detectors company in UK . It was obtained 58.96 cGy/min. It must be mentioned, the cobalt-60 source of this unit has an activity of $85.7 \text{E}12 \text{ Bq}$.

Dose rate calculation

The absorbed dose was calculated in a $10 \text{ cm} \times 10 \text{ cm} \times 0.5 \text{ cm}$ cubic cell (Fig. 5-b) by using MCNP code. Deposited energy in this cell has been obtained $1.80924 \text{ E-}05 \text{ MeV}$ per particle. By using water density (1 gr/cm^3), the cell mass (50 grams), and the activity of the source ($85.7 \text{E}12 \text{ Bq}$) the absorbed dose has been calculated by:

$$Dose - rate = 3.61848 \times 10^{-7} \frac{MeV}{gr.particle} \times 1.6 \times 10^{-13} \frac{J}{MeV} \times 10^3 \frac{Kg}{gr} \\ \times 2 \times 85.7 \times 10^{12} \frac{particle}{second} \times 60 \frac{second}{min} 10^2 \frac{cGy}{Gy} = 59.54 \frac{cGy}{min}$$

Cobalt-60 source emits two photons per decay. Therefore a coefficient of 2 has been inserted above equation.

The percent of relative error can be obtained as follows

$$R = \frac{59.54 - 58.96}{58.96} \times 100 = 0.98\%$$

This result shows there is very good agreement between experimental absorbed dose and calculated data. Therefore, in this case, the data extracted from output file of MCNP code can be reliable.

Reduction of absorbed dose in heart

By using the Monte Carlo simulation of the human trunk, it is possible to calculate absorbed dose by different parts of heart while the stomach has undergone radiotherapy.

The stomach has been considered to be radiated in a field size of 15×16 in 28 sessions while in each session the stomach receives radiation for 5.7 minutes. During this time, some of the energy will be deposited in different parts of heart as absorbed dose. In this study we are going to reduce the amount of total dose absorbed by heart by using a collimator system and lead powder. At first, different thicknesses of lead powder was

experimentally located above the region of heart and the absorbed dose rates were measured by Thermo Luminescent Dosimeter (TLD). The experiment results were shown in Fig. 6. As seen in Fig. 6, the absorbed dose rate in region of heart is decreased with increase of lead thickness. A thickness of 3 cm of lead powder is suitable to reduce heart dose. Because this thickness reduces absorbed dose by:

$$\frac{110.78 - 16.05}{110.78} \times 100 = 85.5\%$$

Therefore, 3 cm thickness of lead powder was used in calculation process.

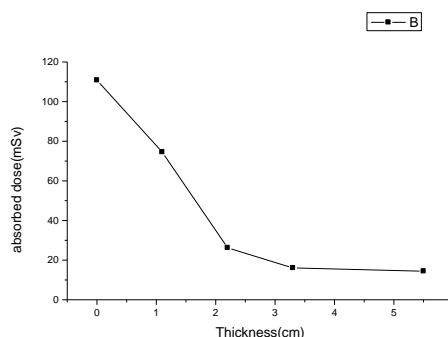

Fig.6. Absorbed dose rate variations in heart region versus lead powder thickness. As seen, about 3cm thickness is suitable to reduce dose rate in heart.

The second step to reduce dose rate is to design a suitable collimator. In a collimator system, if the inner surface of the block is made parallel to the central axis of the beam, the radiation will pass through the edges of the collimating blocks resulting in what is known as the transmission penumbra. The extent of this penumbra will be more pronounced for large collimator openings because of greater obliquity of the rays at the edges of the blocks [7]. In this study a lead collimator with a density of 10.88 gr/cm^3 has been designed to cover the area around the field in such a way the inner surface of the block is parallel to the opening angle of the collimator system of cobalt-60 machine and focuses the beam arrangement just into the field (Figs. 7 and 8).

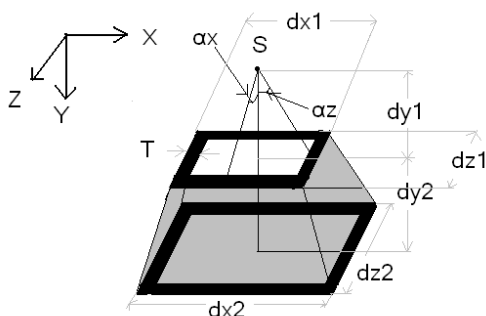
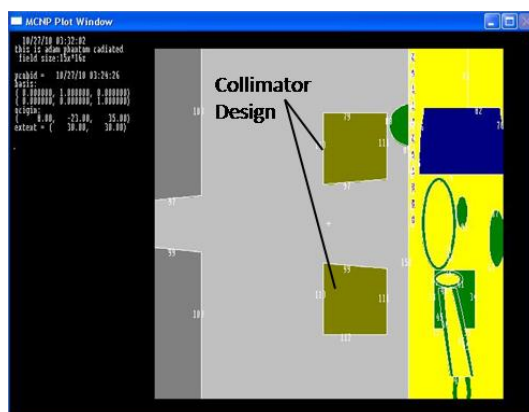

Fig.7. The collimator is designed in such a way the inner surface of the block is parallel to the opening angle (α) of the collimator system of cobalt-60 machine, to minimize the penumbra. value of parameters in figure are: $dy_1=8.15$, $dy_2=80$, $dx_1=12.5$, $dz_1=13.5$, $dx_2=15$, $dz_2=16$, $\alpha_x=4.8^\circ$, $\alpha_z=5.2^\circ$, $T=2.35\text{cm}$, $S=\text{Cobalt Source}$

By considering of parameters that obtained from calculation, input file of MCNP code was established. Designed collimator was located between cobalt source and 3 cm distance above stomach zone of patient body. Plot of designed collimator and radiation zone that extracted from output file of MCNP code shown in Fig. 8.



(b) Fig.8. plot of designed collimator that extracted from output file of MCNP code

Figs. 9 and 10 show absorbed dose of different organs before and after using designed collimator respectively. These results obtained from gamma therapy of a patient that diseased to stomach cancer. By comparing of absorbed dose in heart after and before applying designed collimator on gamma therapy, the effect of collimator can be depicted. The percentage of reduced dose in heart is:

$$\text{Reduced - Dose} = \left| \frac{922.264 - 1446.54}{1446.54} \right| \times 100 = 36.243\%$$

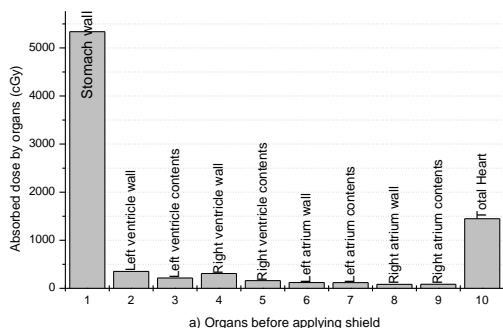

Fig. 9. Absorbed dose in different organs before applying designed collimator during gamma therapy of stomach cancer.

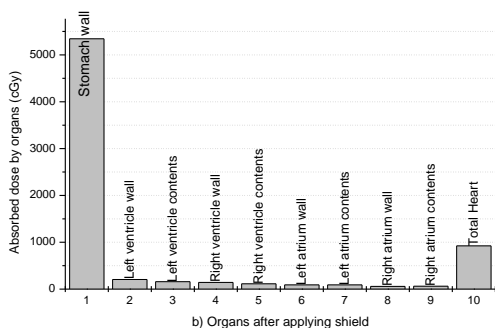

Fig. 10. Absorbed dose in different organs after applying designed collimator during gamma therapy of stomach cancer.

It must be mentioned, the designed collimator effects on absorbed dose in stomach too. It is assumed the stomach has been stricken cancer. Therefore, the

absorbed dose in this tissue must not have noticeable changes with using designed collimator. In this research the change of absorbed dose in stomach is equal +0.1%.

$$\text{Chenged - Dose} = \frac{5344.11 - 5338.316}{5338.316} \times 100 = 0.1\%$$

Thus the effect of designed collimator on absorbed dose in stomach is negligible.

Results

Monte Carlo simulation in radiotherapy has been found to be a useful tool to calculate absorbed dose by internal organs while considering effects of different field sizes, shielding materials and other conditions. The present work demonstrates a useful approach by using MCNP code to investigate the way to reduce the absorbed dose in heart as a surrounding organ of stomach as a radiotherapy target.

As we know, the heart is an important organ in human body. It has a virtual role in body lifetime. The heart pumps about 2000galons blood per day to different tissues. Therefore, reduction of absorbed dose during radiotherapy of stomach cancer tumor is very important. As shown in text, we can experimentally reduce absorbed dose in heart zone about 85% by using lead powder. In addition, the absorbed dose in heart can be decreased by designed collimator. As shown in text, the absorbed dose in heart has been reduced about 36% by using suitable collimator. Whereas, absorbed dose changes in stomach, as a target for radiation, is negligible. It must be mentioned reduction

of dose can be improved by verifying of other methods such as suitable source.

Acknowledgement: The authors would like to thank the staff of radiotherapy center of Razi Hospital in Rasht specially.

References

- [1] Taylor, C.W., McGale, P., Darby, S.C. 2006. Cardiac Risks of Breast-cancer Radiotherapy: A Contemporary View. *Clinical oncology*. 18: 236-246.
- [2] Podgorsak, E.B. (2005). *Radiation Oncology Physics: A Hand book for teachers and students*. IAEA, Vienna.
- [3] Mostaar, A., Allahverdi, M., Shahriari, M. Application of MCNP4C Monte Carlo code in radiation dosimetry in heterogeneous phantom. *Iran. J. Radiat. Res.*, 2003; 1(3): 143 – 149
- [4] Reda, S. M., Massoud, E., Hanafy, M. S., Bashter, I. I., Amin, E. A. 2006. Monte Carlo dose calculations for breast radiotherapy using ^{60}Co gamma rays. *Journal of Nuclear and Radiation Physics*, Vol. 1, No. 1, 2006, pp. 61-72.
- [5] Cristy, M. 1980. *Mathematical Phantoms Representing Children of Various Ages for Use in Estimates of Internal Dose*. ORNL.
- [6] <http://mcnp-green.lanl.gov/manual.html>
- [7] Khan, F.M. 2003. *The physics of radiation therapy*. Lippincott Williams & Wilkins, Philadelphia, USA.
- [8] Miro, R., Soler, J., Gallardo, S., Campayo, J. M., Diez, S., Verdu, G. 2005. MCNP simulation of a theratron 780 radiotherapy unit. *Radiation Protection Dosimetry*. Vol. 116, No. 1–4, pp. 65–68.



Conflict of Interest None Declared