

Design Loop Inductor Coil Sensor for ELF Noise Signals

Rajendra, Aparnathi¹, Ved Vyas, Dwivedi²

¹Research scholar, Faculty of Technology & Engineering,
C. U. Shah University, Wadhwan city, Gujarat, India
rajendraaparnathi@gmail.com

²Pro Vice Chancellor, C. U. Shah University,
Wadhwan City, Gujarat, India
provcushahuniv@gmail.com

Abstract: This project Research paper for detecting magnetic fields in the extremely low frequency range and extremely low noise are developed, including the antenna, transformer base frequency amplifier. Each component is described with relevant cut-offs which allow a large variation of receivers to be easily designed for any magnetic field loop coil sensing in the ultra-low frequencies noise range. This paper introduces a new ELF noise signal Inductor Loop-sensor design and finds stability for pre-amplifier. A system using different impedance value base antenna is developed further that has been used extensively in measurement application in the frequency below range of extremely low using tools such as MATLAB software base.

Keywords: ELF-Extremely low frequency, Amplifiers, loop antennas, magnetic field measurement, magnetometers

1. Introduction

The induction coil sensor is called also search coil sensor, pickup coil sensor, magnetic antenna is one of the oldest and wellknown magnetic sensors .Magnetic field receivers are used to sense low-frequency [(LF); <30 kHz] electromagnetic waves because of their superior noise performance at low frequencies and their relative different of nearby metallic aloe structures compared to electric field sensors. Superconducting Quantum Interference Devices (SQUIDS) are commonly available frequency amplifiers in this frequency range. These generally use a high-input impedance amplifier and then use feedback to reduce the input impedance gain as seen by the sensor although good noise modules performance is obtained; they must be operated below the critical temperature of the superconductors, near -273.15°C . In general, it is difficult to design a SQUID-based amplifier to have input impedance as low as is required while remaining stable [1].we design system in room temperature also uses a In loop topology [2] An intelligent sensor is a system usually consisting of a chain of analog and digital blocks, each of which provides a specific function. Sensors or transducers of particular physical quantities described in other chapters constitute only small but important part. Figure 1 shows the structure of an intelligent sensor. Of course, not every intelligent sensor contains all the presented blocks; it depends on sensor type and functionality.

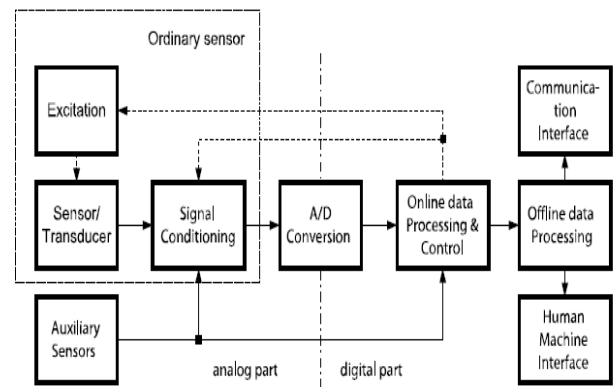

Figure 1: The structure of an intelligent sensor.

The sensor or transducer usually provides some electric quantity output (e.g. voltage, current or impedance), which depends on the value of measured physical quantity (either electric or non-electric). Many sensor types require external excitation to work, usually electric, but sometimes also magnetic or mechanic excitation. A signal conditioning block may provide amplification, filtering, nonlinearity correction and similar functions [2]. Usually they are implemented using analog circuits, but digital implementation (especially of specific functions like nonlinearity correction or environmental influence compensation) becomes more frequent. An A/D converter block converts analog signal into digital values, suitable for processing by microprocessor or other digital devices. The following blocks are implemented either in digital hardware (ASIC, PLD) or in software (running on the

microcontroller). The online data processing and control block provides part of the signal conditioning, and for some sensor types it controls excitation parameters or analog signal conditioning processes (e.g. synchronous detection). The offline data processing block receives instantaneous values of measured quantities. It is more focused on data storage, report generation, trend evaluation, etc. The last two blocks are well known to users; the HMI (Human Machine Interface) allows local sensor control and data output, and the communication block provides an interconnection to the system controller via the distributed system. Some intelligent (as well as ordinary) sensors also contain an auxiliary sensor that measures other physical quantity interfering with the main sensor output. A typical example is an auxiliary temperature sensor used to compensate the unwanted temperature influence. A signal-conditioning block is mainly used to extract information about the measured quantity from the sensor output signal and to match it to the input of the following block – an A/D converter [3]. It typically implements some (or all) of the following functions – amplification and signal conversion, sensor insulation, filtration, detection, non-linearity correction, and environmental influences correction. Sometimes selected functions (especially the non-linearity and environmental corrections, more rarely the filtration or detection) are implemented later in the chain within the data processing block. Often the SC block also contains the circuits that allow sensor and/or sensor connection diagnostics. This feature is necessary for sensors whose failures could cause a large amount of physical damage or even risk personal safety.

2. Amplification and Signal Conversion

Amplification and signal conversion is nearly always used, as direct sensor output signal magnitudes are usually low. In case the output electric quantity of the sensor is not a voltage, voltage signal conversion is usually applied before further processing [4].

Sensor insulation [4].

Galvanic insulation is often required to avoid ground loop currents that introduce errors in the measuring chain. Insulation also provides a barrier against interfering voltage spikes coming from the examined technology that may damage electronic circuits. Galvanic insulation of the sensor is also required if there is a higher voltage difference between the technology the sensor is mounted on and the sensor itself.

Filtration [4].

Filtration is a very important part of the SC block and can be found in nearly every intelligent sensor. The sensor output signal that carries information about the measured quantity is often distorted by a number of noise sources that can be (at least partially) removed using filtering. A low-pass, high-pass, band-pass, stopband, notch filter or a combination of these is applied depending on the specific situation.

In conjunction with sampling and A/D conversion, anti-aliasing filters are often applied. They are usually higher order low-pass filters that are used so that the output signal satisfies the sampling theorem.

Detection [4].

The higher frequency signal envelope sometimes carries information about the measured physical quantity, e.g. in some SC circuits for the eddy current distance sensor (see Chapter 7)[3]. Detection is then used to extract the envelope amplitude. Often a synchronous detection is used in order to increase the signal to noise ratio, e.g. in SC circuits for optical sensors (see Chapter 2)[3] or LVDT displacement sensor (see Chapter 7)[3]. Many sensors provide information encoded into the phase shift between the excitation and output signals. Synchronous detection is used here as well, providing 0° and 90° components. In this paper, we describe a sensitive Extreme very Low frequency receiver design method originally developed by R.R.Aparnathi, V.V Dwivedi. The various design equations and trade of fr of the antenna, transformer base Signal conditioning (SC) Extreme-low-noise generated are discussed. Section II begins by describing the design of Amplification and signal conversion and Sensor insulation. Developed in Section III and Section IV follows, describing the amplifier design. In Section V, an example system using a very low value ohm and some value inductive antenna design is presented, and the corresponding performance is shown in Section VI.

3. Design of the Air Coil Sensor Base Transformer

The sensor or transducer usually provides some electric quantity output (e.g. voltage, current or impedance), which depends on the value of measured physical quantity (either electric or non-electric) show in Figure.2

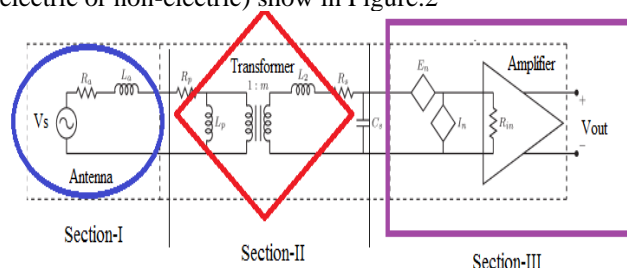

Figure.2: System design of fully differential magnetic field receiver, including antenna model, transformer model, and noise model of amplifier

Table 1: [1, 3]

Constants Forvariou smagnetic loop antenna shapes			
Sr.No	Shape of Loop	Constant 1	Constant 2
1	Circular	3.545	0.815
2	Regular Octagon	3.641	0.925
3	Regular Hexagon	3.722	1.000
4	Square	4.000	1.217
5	Equilateral triangle	4.559	1.561
6	Right Isosceles Triangle	4.828	1.696

Winding capacitance and skin effects are negligible at these frequencies. It is therefore important to derive the relationship among the three parameters and the resulting Ra, La, and sensitivity. Loop shape is usually chosen based on its ease of construction given a desired area. A variety of

common loop The constant C_1 is related to the geometry of the antenna and allows for a general expression of the length of each turn that is valid for any shape Antenna Turn Length shapes available are listed in Table I. The constant C_1 is related to the geometry of the antenna and allows for a general expression of the length of each turn that is valid for any shape Antenna Turn Length

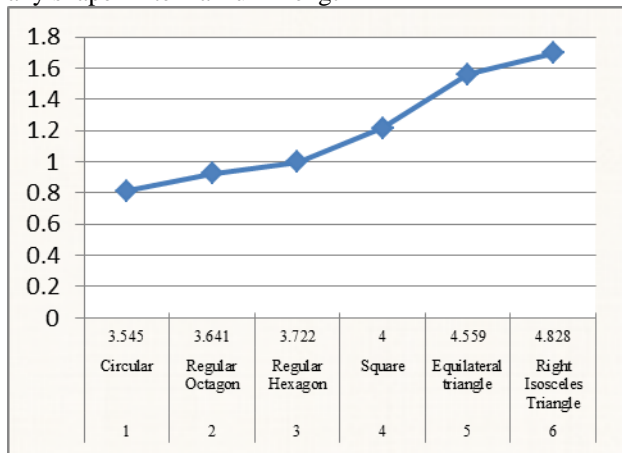

Graph gain between types of loop Inductive coil sensor

$$= C_a \sqrt{A_a} \tag{1}$$

Using this expression, the antenna resistance for any shape is

$$R_a = \frac{4\rho N_a C_1 \sqrt{A_a}}{\pi d^2} \tag{2}$$

Where ρ is the resistivity of the wire (for copper, $\rho = 1.72 \times 10^{-8} \Omega m$), and d is the diameter of the wire. Adapting from [6, pp. 49–53], the inductance for any loop antenna is

$$L_a = 2.00 \times 10^{-7} N_a^2 C_1 \sqrt{A_a} \left[\ln \frac{C_1 \sqrt{A_a}}{N_a d} - C_2 \right] \tag{3}$$

Where C_2 is also a geometry-related constant and can be found in Table I for a variety of loop shapes. The two variables R_a and L_a form the total impedance of the antenna (Z_a) that is the source impedance seen by the first stage of the receiver

$$Z_a = R_a + j\omega L_a \tag{4}$$

where f is the frequency, B is the magnetic flux density, and θ is the angle of the magnetic field from the axis of the loop. If the axis of the loop is horizontal, the response pattern of the antenna is a dipole in azimuth. In the following, we shall be concerned with the response of the loop to an appropriately oriented field and will omit the term $\cos(\theta)$. Since a VLF receiving loop is very small compared to a wavelength ($\lambda = 1000 \text{ Km}$ at 300 Hz and 10 Km at 30 KHz), the radiation resistance of the loop is negligible compared to the wire resistance R_a . The minimum detectable signal is limited by the thermal noise of R_a . We define the sensitivity of the antenna S_a as the field equivalent of the noise density, i.e., the amplitude of an incident wave which would give an output voltage equal to the thermal noise of R_a in a 1-Hz bandwidth. Using (5), we can also design VLF and ELF Amplifier receiving loop very small compared to wave length as very small noise signal 0.1 to 3 Hz, we can express the sensitivity as Q_a is sensitivity

$$Q_a = \frac{\sqrt{4kTR_a}}{2\pi f N_a A_a} \tag{5}$$

The antenna sensitivity S_a decreases with frequency (i.e., the antenna becomes more sensitive) at $1/f$. It is convenient to define a frequency-independent quantity for comparing the performances of different antennas. We define the normalized sensitivity as $\hat{Q}_a = f Q_a$. Using Rain (2), we find an expression for the normalized sensitivity that depends only on the physical parameters of the antenna

$$\hat{Q}_a = \frac{\sqrt{4kT\rho C_1}}{\pi^{3/2} \sqrt{N_a A_a^{3/4}}} \tag{6}$$

This expression for sensitivity can be used to find the number of turns, antenna area, and wire diameter required for a target sensitivity at a specific frequency. The effect of the resulting antenna resistance and impedance on the rest of the system is discussed in later sections. Further insight can be gained by recalculating this sensitivity as a function of the mass of the antenna. The mass of the wire used in the antenna can be calculated as

$$K = \frac{1}{4} \pi \delta c_1 d^2 \sqrt{N_a} \tag{7}$$

Where K is Gain where δ is the density of the wire. Solving this for $d = \sqrt{N_a}$ and substituting into (7) produce normalized sensitivity

$$\hat{Q}_a = \frac{c_1 \sqrt{4kT\rho\delta}}{2\pi \sqrt{M A_a}} \tag{8}$$

This interesting result shows that the only way to improve sensitivity with a given antenna material is to increase the total mass or area of the antenna. These receivers are usually placed in remote areas to reduce interference from power lines (at 60 Hz and harmonics); thus, this fundamental tradeoff means that the sensitivity must be balanced against practical limitations regarding weight and size. Since the Earth's magnetic field lines that pass through these regions in the upper atmosphere cross the Earth's surface at the poles, it is the only place that a ground-based receiver can detect the ELF noise signals 0.1 to 3.0 Hz that follow these field lines [5],[6].

A Fabrication of design of an air coil sensor with transformer is presented in Fig.2. The resultant area of a multilayer coil sensor can be determined by performing integration Relation (9) is of limited accuracy, therefore in practice it is better to determine the resultant area of the coil experimentally by means of calibration in a known field. For the sake of straightforwardness for further analysis of the sensitivity in this project, the area is determined by using a simplified formula obtained by assumption that the diameter of the coil is equal to mean value $D_m = (D + D_i)/2$, thus

$$A = \pi / 4 \int_{D_i}^D (Y^2) dy = \frac{\pi}{12} \cdot \frac{D^3 - D_i^3}{D - D_i} \tag{9}$$

$$A = \frac{\pi}{8} \cdot (D + D_i)^2 \tag{10}$$

If we assume that flux density to be measured is a sine wave $b = B_m \sin(\omega \cdot t)$,

$$V = 0.5 * \Pi^2 . f . n . D^2 . B \tag{12}$$

where f is a frequency of the measured field, n and number of turns and diameter of the coil, respectively. Bis the measured flux density.

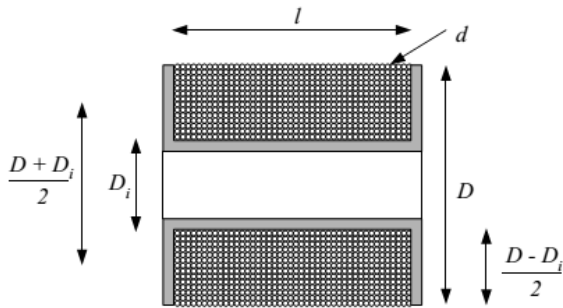

Figure.3: Typical design of an air coil sensor (l-length of the coil, D- diameter of the coil, Di- internal diameter of the coil, d—diameter of the wire)

Various publications discussed other geometrical factors of the air coil sensor. For instance, the optimum relation between the length and the diameter of the coil can be determined taking into account the error caused by inhomogeneous field. It was found [7], [8] that for $l/D = 0.866$ the undesirable components are eliminated at the center of the coil. This analysis was performed for the coil with one layer. For a multilayer coil this recommended relation is $l/D = 0.67 - 0.866$ (0.67 for $D_i/D = 0$ and 0.866 for $D_i/D = 1$). The same source [9] recommends D_i/D to be less than 0.3 . It can be concluded from the analysis presented above that in order to obtain high sensitivity the air coil sensor should be very large. For instance, the induction coil magnetometer used for measurements of micropulsations of the Earth’s magnetic field in the bandwidth $0.001-10$ Hz with resolution 1 pT – 1 nT. The coil with diameter 2 m ($16\ 000$ turns of copper wire 0.125 mm in diameter) detected micropulsation of flux density in the bandwidth $0.004 - 10$ Hz. For 1 pT field the output signal was about $- 0.32$ μ V, whilst thermal noise level was about 0.1 μ V. The air coil sensor with $10\ 000$ turns and diameter 1 m was used to detect flux density of magnetic field in pTrange (for magnetocardiograms) Coil sensors are sensitive only to the flux that is perpendicular to their apertures. Therefore, in order to determine all directional components of the magnetic field vector, three mutually perpendicular coils should be used Sensors with ferromagnetic core are often used for magnetic investigations in space research [9], [10]. Devices with the length of core 51 cm and the weight 75 g (including preamplifier) exhibited the resolution (noise level) 2 fT/ $\sqrt{\text{Hz}}$ [11]. In analysis of the space around the Earth (coil experiments) the following three-axis sensors have been used: coil $100\ 000$ turns of 0.036 mm in diameter, core made from nickel-iron alloy 27 cm long and square (0.6×0.6 cm) cross-section . Each sensor weighted 150 g (a half of the weight was the core weight). The sensitivity was 10 μ V/nT Hz [12]. There are commercially available search coil sensors.

4. Electronics Circuit Connected to the Colie Sensor

The output signal of an induction coil is dependent on the derivative of the measured value (dB/dt or dI/dt in the case

of Rogowski coil) one of the methods of recovering the original signal is by means of an integrating transducer

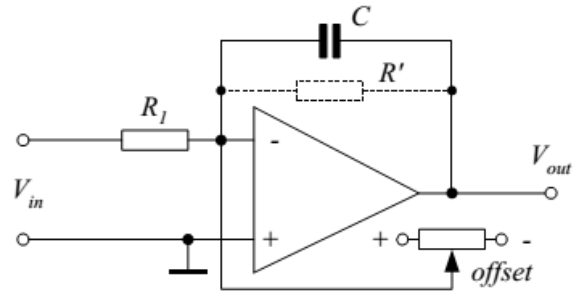

Figure.4: The integrating circuit for the coil

The amplifier can introduce several limitations in the high frequency bandwidth. A passive integrating circuit (Fig.3) exhibits somewhat better performance in this bandwidth. Combinations of various methods of integration (active and passive) can be used for large bandwidth– as proposed in Problems with correct designing of a measuring system with integrating transducer are often overcome by applying low resistance loading of the coils (self-integration mode presented in Fig. 2). Usually, a current-to-voltage converter is used as an output transducer, sometimes additionally supported by a low-frequency correction circuit in using in filter in Fig.4.

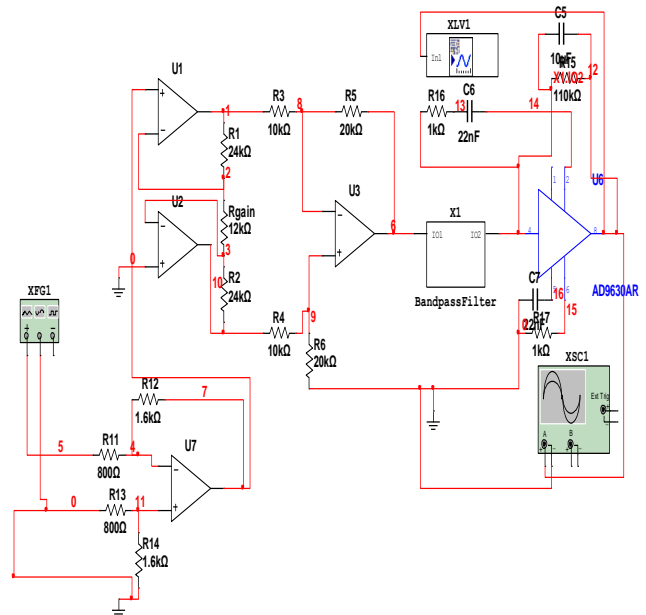

Figure.5: the band pass filter integrating circuits with amplifier

The amplifier connected to the coil sensor introduces additional noise – voltage noise and current noise, as it is illustrated in Fig. 4. Each noise component is frequency dependent. Analysis of the coil sensor connected to the amplifier [13] indicates that for low frequency the thermal noise of the sensor dominates. The resonance frequency the amplifier noise dominates in Fig.5. For investigations of magnetic frequency gain in Fig.7 the author designed and constructed magnetometer consisting of an air coil sensor Fig.6 and amplifier/frequency correction system. Typically measuring instruments are equipped with several sensors with amplifier used in extremely low frequency sense.

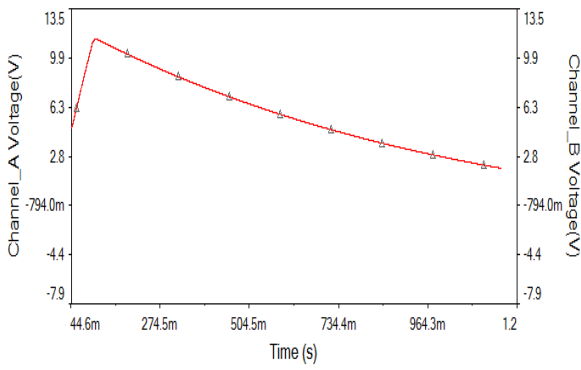

Fig.5 resonance of amplifier results

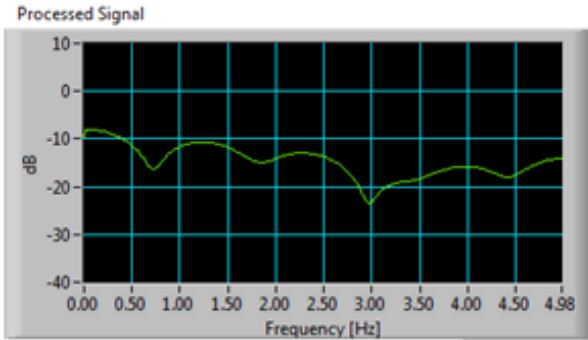

Figure.6: A typical response of a gradient coil sensor to the source distanced from the pickup coil

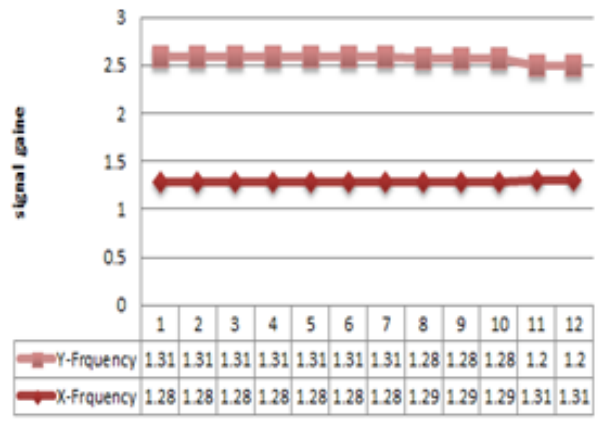

Figure.7: Gain of signals response

5. Conclusion

This research paper is find extreme low frequency for noise signal for ferromagnetic effect or low frequency effect sense. The induction sensors used for the magnetic field measurements has been known for many years. The inductive antenna sensor is working for elf frequency sense and find All factors (number of turns, cross-section area) can be accurately determined and the dependence is excellently linear without upper limit (without saturation). The coil sensor also using in gain and electromagnetics frequency sense and find the value of current and power of signals. This band was situated deliberately to the frequency interval of 0.5 - 30 Hz. In the following works, it is necessary to optimize antenna sensor aperture size from the point of view of reasonable dimensions and to carry on set of measurements allowing detection of the human body imprisoned under the show avalanche it is rather difficult to

miniaturize the induction coil sensors because their sensitivity depends on the sensor area (or the length of the core). Today, it is still in common use due to its important advantages: simplicity of operation and design, wide frequency bandwidth and large dynamics. The performance of the induction coil sensor can be precisely calculated. The case of core coil sensor is more complicated, because the permeability depends on the magnetic field value and/or temperature. But if the core is correctly designed, then these in fluencies can be significantly reduced. Two methods are used for the output electronic circuit: the integrator circuit and the current to voltage transducer. Although digital integration techniques are developed and commonly used, the analogue techniques, especially current to voltage transducers, are often applied due to simplicity and good dynamics

References

- [1] W. Rogowski, W. Steinhaus, "Die Messung der magnetischen Spannung", ("The measurements of magnetic potential") Arch. für Elektrotechnik, vol. 1. 1912, pp. 141-150
- [2] G. Dehmel , "Magnetic field sensors: Induction coil (search coil) sensors", Chapter 6 in Sensors a comprehensive survey, vol. 5, VCH Publishers, 1989, pp. 205-254
- [3] P. Ripka , "Induction sensors", Chapter 2 in Magnetic sensors and magnetometers, Artech House, 2001, pp. 47-74
- [4] H. Zijlstra, "Experimental methods in magnetism", North-Holland Publishing, 1967
- [5] A.P. Chattock, "On a magnetic potentiometer", Phil. Magasine, vol. 24, 1887, pp. 94-96
- [6] P. Murgatroyd, "Progress with Rogowski coils", EMCWA Conf., Chicago, 1996, pp. 369-374
- [7] W.Richter, "Induction magnetometer for bio magnetic fields" (Induction magnet to meter for bio magnetise Felder), Exp. Technik der Physik, vol. 27, 1979, pp.235-243
- [8] S. Tumanski, "A multi-coil sensor for tangential magnetic field investigations", J. Magn. Magn. Mat., vol. 242-245, 2002, pp. 1153-1156
- [9] G.H. Shirkoohi, A.S. Kontopoulos, "Computation of magnetic field in Rogowski-Chattock potentiometer compensated magnetic tester", J. Magn. Magn. Mat., vol. 133, 1994, pp. 587-590
- [10] E. Werner, „Einrichtung zur Messung magnetischer Eigenschaften von Blechen bei Wechselstrommagnetisierung“, („The device for testing of electrical steel magnetized by AC field“), Austrian patent. No. 191015, 1957
- [11] K. Senda, M. Ishida, K. Sato, M. Komatsubara, T. Yamaguchi, „Localized magnetic properties in grain-oriented silicon steel measured by stylus probe method“, Tran. IEEE of Japan, vol. 117-A, 1997, pp. 941-950
- [12] H. Pfützner , G. Krismanic, „The needle method for induction tests – sources of error“, IEEE Trans. Magn., vol. 40, 2004, pp. 1610-1616
- [13] R.J. Prance, T.D. Clark, H. Prance, "Compact room-temperature induction magnetometer with

superconducting quantum interference level field sensitivity”, Rev. Sc. Instr., vol. 74, 2003, no. 8, pp. 3735-3739

Author Profile



Assist.Prof.Rajendra Aparnathi. received his B.E(Electrical Engineering) degree from Bhavnager University,qualified GATE-2009, and M.E. (Industrial Electronics) from the Faculty of Technology and Engineering,Maharaja Sayajirao University of Baroda. P.hd*(Pursuing) CUShah University, Wadhwancity,

Surendranagar,Gujarat:INDIA The major fields

of interest are Industrial Automation and Power Systems. He joined C U Shah College of Technology and Engineering, C U Shah University, Gujarat-India and Gujarat Technology University,

Gujarat, India and as an Assistant Professor.

Now he is the tutor of graduate students and Post graduate students majoring in Power Electronics and Drives. In recent years his research interests focus on the field of renewable energy, especially on the inverter technology. He also worked on R&D project with companies of repute in the field of electrical electronics engineering



Dr. Ved Vyas Dwivedi, Professor– Gujarat Technological University, Ahmedabad; Pro-VC in C U Shah University, wadhwancity, Gujarat- INDIA; is a Ph. D., M.E., B.E. (all E.C. Engineering) has submitted his Post-doctorate report; is a recognized Ph. D. guide for 06 candidates in R. K. Univ. Rajkot (Gujarat), Pacific Univ. Udaipur, J.J.T. Univ. Jhunjhunu; 02 Ph. D. theses and 36 M Tech dissertations submitted, and no. of papers published ~ 125, no. of expert talks delivered ~ 47 in international conferences, workshops, STTP...; completed 03 research projects / consultancy (Govt. and nongovernment organizations). His fields of research interest are energy-sensor-wireless-optical-radar-satellite-RF technologies and systems.