



Article citation info:

Urbanský, M., Kaššay, P. The new realized mobile device for extremal control research and presentation. *Scientific Journal of Silesian University of Technology. Series Transport*. 2015, **89**, 173-178. ISSN: 0209-3324. DOI: 10.20858/sjsutst.2015.89.18.

Matej URBANSKÝ¹, Peter KAŠŠAY²

THE NEW REALIZED MOBILE DEVICE FOR EXTREMAL CONTROL RESEARCH AND PRESENTATION

Summary. At our department we deal with torsional oscillating mechanical systems (TOMS) continuous tuning during its operation in terms of torsional oscillation size. Therefore was build the new mobile device for research and presentation purposes of the TOMS continuous tuning using extremal control method. This paper deals mainly with design of the mobile device and its special compressed air distribution system, which is necessary for its regular function.

Keywords: torsional oscillating mechanical system, continuous tuning, extremal control

1. INTRODUCTION

In the laboratory of our workplace – Section of machine design and machine parts of Department of Construction, Automotive and Transport Engineering we attend to measuring and tuning of torsional oscillation in torsional oscillating mechanical systems (TOMS), mainly during their operation, i.e. publications [1-6, 8]. One of the methods of continuous tuning is the application of the extremal control – experimental optimization, which is detailed described i.e. in publications [2-4]. For research and presentation purposes of TOMS continuous tuning using extremal control method was build the new mobile mechanical device (Fig. 1). For regular function of this device was moreover necessary to build the special compressed air distribution system. This paper therefore deals with design of this

¹ Faculty of Mechanical Engineering, Department of Construction, Automotive and Transport Engineering Technical University of Košice, Letná 9 Street, 042 00 Košice, Slovakia. E-mail: matej.urbansky@tuke.sk

² Faculty of Mechanical Engineering, Department of Construction, Automotive and Transport Engineering Technical University of Košice, Letná 9 Street, 042 00 Košice, Slovakia. E-mail: peter.kassay@tuke.sk

mobile device and its special compressed air distribution system and with determination of volume of air springs, which are modified and used as air pressure tanks.

2. DESCRIPTION OF THE NEW BUILD MOBILE DEVICE

In Fig. 1 we can see that the basic part of this new build mobile device is the torsional oscillating mechanical system (TOMS). This TOMS consists of 3-phase asynchronous electromotor MEZ 4AP132M-4 (nominal power 7,5 kW at 1450 min^{-1}) (1), whose rotation speed is continuously vector-controlled by the frequency converter Sinamics G120C (2). Electromotor drives the 3-cylinder piston compressor ORLIK 3JSK-75 (3) through the pneumatic tuner of type 4-2/70-T-C (4). This TOMS is situated on rigid frame, which is flexibly mounted on the mobile platform (5). Next component situated on the mobile platform (5) is electronic extremal control system called ESLER (6) and its accessories (sensors, actuators, etc.). Current level of ESLER function is in detail described in [4] and the whole process of torsional oscillation data measuring and evaluation using optical sensors is described in detail in [8].

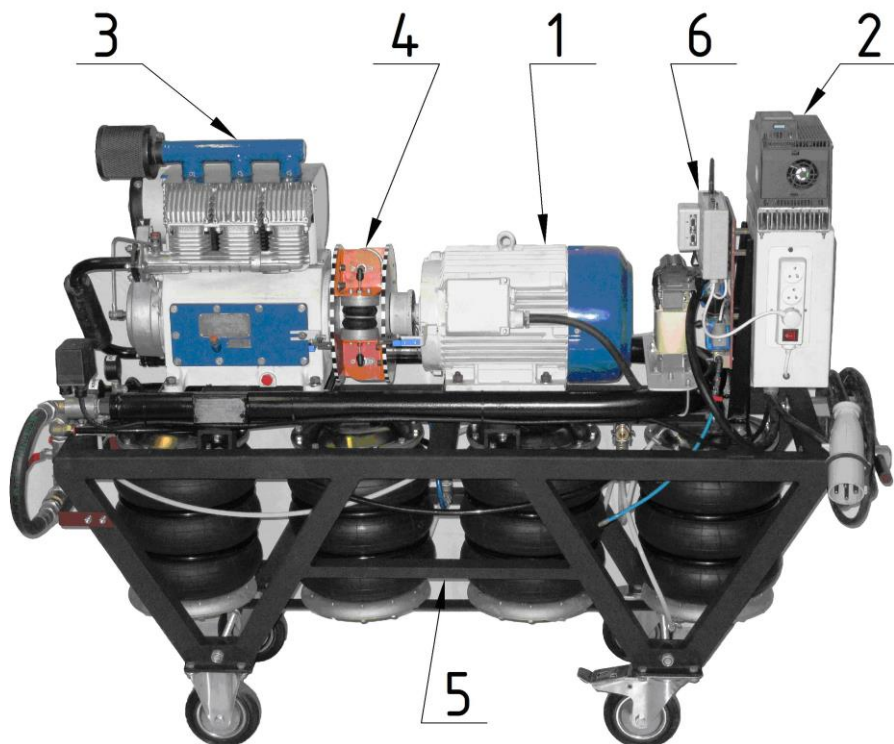

Fig. 1. The new build mobile device for extremal control presentation

As base for the mobile device construction was therefore used the standard ORLIK compressor system (Fig. 2), with originally air pressure tank (300 l of volume) and with flywheel and originally flexible coupling of type HARDY. By reason of torsional oscillation effects increasing was the flywheel removed in the new build mobile device.



Fig. 2. The standard compressor system ORLIK

3. MOBILE PLATFORM WITH COMPRESSED AIR DISTRIBUTION SYSTEM

The main parts of the mobile platform (position (5) in Fig. 1) are the steel frame, four air springs RUBENA 340/3, modified (Fig. 3) and used as air pressure tanks and the special compressed air distribution system (Fig. 4).

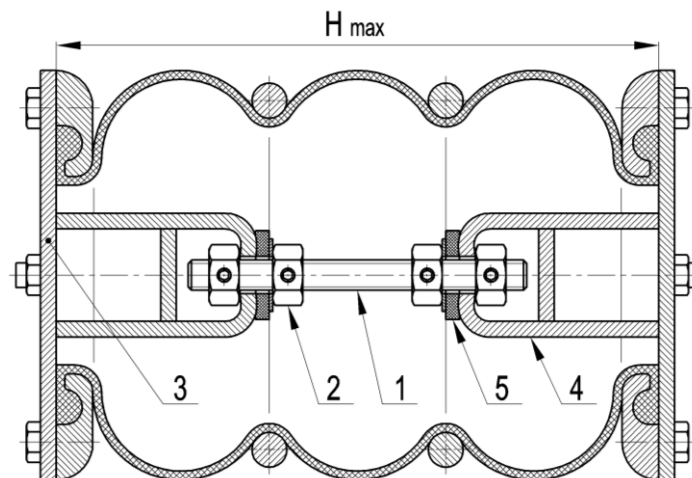

Fig. 3. The modified air spring

The mobile platform must insure the following functions:

- carrying and transport of whole system,
- compressed air storage for pneumatic coupling inflation,
- compressor delivery pipe volume compensator for properly adjustment of compressor delivery pressure and thereby TOMS load too.

Modified air springs RUBENA 340/3 were used as air pressure tanks (Fig. 3). The threaded rod (1), situated in air spring axis (axis of rotational symmetry) with four lock-nuts (2) screwed on it are keeping from unwanted air spring extension at its inflation and

unwanted air spring retraction at its deflation, mainly when in the air spring is zero overpressure value. Axial forces from air spring sealing flanges (3) to the threaded rod are transmitted through cross-stiffened forks (4), welded to inner sides of air spring sealing flanges. The hard rubber plates (5) between lock-nuts allow small parallelism deviations of air spring sealing flanges. The air spring stroke is therefore constant and it is adjusted to value $H_{\max} = 340$ mm, which is maximal air spring stroke operation value according to manufacturer catalog [8]. Maximal air overpressure in the tanks is 700 kPa.

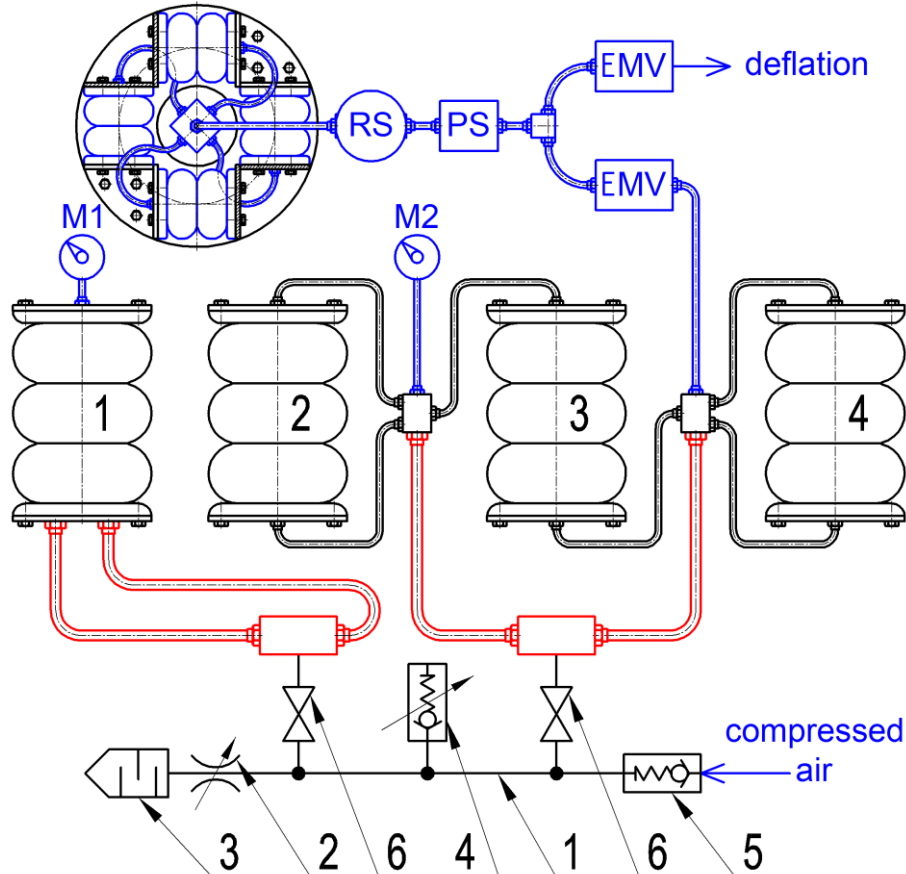

Fig. 4. The special compressed air distribution system

The special compressed air distribution system (Fig. 4) allows through inter-connections the use of modified air springs as:

- compressed air storage for pneumatic coupling inflation (air springs 2,3,4),
- compressor delivery pipe volume compensator (air spring 1).

In Fig. 4 we can see that the compressed air from compressor streams into the compressor delivery pipe (1) (1" piping), which finished with throttle valve (2) and noise silencer (3). With this throttle valve we can adjust compressor delivery overpressure and thereby the TOMS load too, since the transmitted load torque in TOMS at certain constant rotational speed increases with increasing compressor output air overpressure [9]. For accurate and comfortable adjustment of compressor delivery pressure is to delivery pipe connected the volume compensator (air spring 1). Whole compressor delivery pipe is protected against inadmissible overpressure increase by mechanical safety pressure valve (4) (after backflow valve (5)) and by electrical safety pressure valve – total stopper (before backflow valve, do not shown in Fig. 4). Interconnected air springs 2,3,4 serve as compressed air storage for

pneumatic coupling inflation. Compressed air streams through electromagnetic valve (EMV), pressure sensor (PS) and rotational air supply (RS) into pneumatic coupling. Air spring 1 and interconnected air springs 2,3,4 can be using ball lock valves (6) alternately connected on or disconnected off the compressor delivery pipe, as necessary. It is necessary to say that all actuating components (2), (6) and indicators (manometers M1 and M2) must be situated so close together as possible and they must allowing good manipulation and view. At the same time that components must be situated beyond reach of rotary or electrical parts of mechanical system. In our case they are situated on the left frame forehead (Fig. 1).

4. APPROXIMATE DETERMINATION OF AIR SPRINGS VOLUME

For computation of certain next parameters of the system was necessary to determine the approximate volume of modified air springs, described in previous chapter. This determination was realized on the principle of air pressure equalization between known volume V_N (300 l air pressure tank – Fig. 2) and unknown volume of the special compressed air distribution system V_S (Fig. 2, without pneumatic coupling compression space). It was isothermal process under consideration:

$$V_S = V_N \cdot \left(\frac{P_{pN} - P_{pC}}{P_{pC}} \right), \quad (1)$$

Where p_{pN} is air overpressure in the 300 l pressure tank and p_{pC} is air overpressure after air pressure equalization.

Because of isothermal process was considered, it was important to wait enough long time for p_{pC} and p_{pN} values consolidation. For accurate measurement of the pressure was used the pressure sensor of type Danfoss MBS 3000 (0÷10 bar range of measure).

Table 1

Measured and computed values for air springs volume determination

p_{pN} [kPa]	800	750	700	650	600	550	500	450	400
p_{pC} [kPa]	628,6	590,3	552	513,5	474,6	435,8	397,1	358,4	319,5
volume V_S [l]	81,7	81,2	80,4	79,7	79,3	78,6	77,7	76,7	75,6
1 air spring volume [l]	20,17	20,04	19,86	19,69	19,57	19,40	19,18	18,92	18,65

From Tab. 1 we can see that the average 1 air spring volume is 19,5 l. Values of V_S increase with increasing p_{pN} values. This fact is caused by extensibility of air springs rubber-textile coat. Volume of 1 air spring is computed without the piping-volume.

5. CONCLUSION

In term of safety of our new build mobile device is even necessary to install protection covers in TOMS, namely:

- rotary parts cover, mainly over pneumatic coupling,
- pneumatic system cover around steel frame,
- electrical parts cover over choke coil and frequency converter terminal board.

References

1. Grega Robert. 2014. „Examination of applicated pneumatic flexible coupling and its effect on magnitude of vibrations in drive of belt conveyer”. *Scientific Journal of Silesian University of Technology. Series Trasnsport* 85 (4): 21-25. ISSN 0209-3324.
2. Homišin Jaroslav. 2002. *Nové typy pružných hriadel'ových spojok: Vývoj-Výskum-Aplikácia*. Košice: Vienala. ISBN 80-7099-834-2. [In Slovak: *New types of couplings flexible shaft: Development-Research-Application*].
3. Homišin Jaroslav, Peter Kaššay. 2014. „Experimental verification of the possibility using pneumatic flexible shaft couplings for the extremal control of torsional oscillating mechanical system”. *Diagnostyka* 15 (2): 7-12. ISSN 1641-6414.
4. Homišin Jaroslav, Matej Urbanský. 2015. „Partial results of extremal control of mobile mechanical system”. *Diagnostyka* 16 (1): 35-39. ISSN 1641-6414.
5. Patent no.259225. *Regulačný systém pre zabezpečenie plynulej zmeny charakteristiky pneumatických spojok*. Homišin Jaroslav. 1987. [In Slovak: *Regulatory system to ensure smooth changes in the characteristics of pneumatic clutches*].
6. Patent PL 216901 B1. *Układ mechaniczny strojony w sposób plynny*. Homišin J. 2014. [In Polish: *Mechanical tuned smoothly*].
7. Rubena. „*Air Springs / Couplings / Compensators / Washers*”. Available at: <http://www.rubena.cz/air-springs/t-659/>
8. Urbanský Matej, Jaroslav Homišin. 2014. „Use of optical sensors for measuring of torsional oscillation size”. In: *Inżynier 21. wieku: 4. Międzynarodowa Konferencja Studentów oraz Młodych Naukowców*: 343-348. Akademia Techniczno-Humanistyczna, Bielsko-Biała, Poland. 05 December 2014, Bielsko-Biała. ISBN 978-83-63713-89-8.
9. Urbanský Matej, Pavol Čopan. 2013. „Comparison of the measured torque-revolutionar characteristics of driven device”. *Zdvíhací zařízení v teorii a praxi*, 8 (1): 2-8. ISSN 1802-2812.

This paper was written in the framework of Grant Project VEGA: „1/0688/12 – *Research and application of universal regulation system in order to master the source of mechanical systems excitation*”.

Received 23.10.2014; accepted in revised form 25.06.2015



Scientific Journal of Silesian University of Technology. Series Transport is licensed under a Creative Commons Attribution 4.0 International License