



Significance of Electronics and Luxury Car Sophistication through ECU: A Progressive Study of Evolution in Automobile Industry

Vijay Laxmi Kalyani, Miti Bhatnagar, Lavina Shivnani, Era Verma.

*Vijay Laxmi Kalyani, HOD Electronics and Communication Engineering, Govt. Women's Engineering College, Ajmer, India.
vijaylaxmikalyani@yahoo.com*

*Miti Bhatnagar, B.Tech student Electronics and Communication Engineering, Govt. Women's Engineering College, Ajmer, India.
mesmerisingmiti96@gmail.com*

*Lavina Shivnani, B.Tech student Electronics and Communication Engineering, Govt. Women's Engineering College, Ajmer, India.
Era Verma, B.Tech student Electronics and Communication Engineering, Govt. Women's Engineering College, Ajmer, India.*

Abstract: Electronics is a cosmic branch of engineering; it has its presence almost everywhere. From last 2-3 decades the automobile industry has gone through many drastic changes since earlier days. The oldest automobile companies were FIAT, HM (Hindustan Motors) etc. Later on MARUTI came into picture changing the economy of the automobile industry, Maruti 800 with sales of 2.4 million; it was the top selling car in India. Further, manufacturers like TATA, MAHINDRA, TOYOTA, etc. were in market with latest updating in technology in Indian automobile. In cars, like human brain the ECU (Engine Control Unit) is the brain of cars. The ECU plays a major role in the performance of the engine of a car's fuel injection system. In this paper the author(s) is going to highlight the role of electronics in automobile and with the help of electronics how ECU plays a major role in the performance of the engine of a Luxury car's fuel injection system.

Keywords - Automobile, Use of Electronics in Automobiles, Applications, Engine Control Unit (ECU), Sensors

I. INTRODUCTION

In today's world the automobile industry are becoming more and more dependent on electronic components. Different types of systems of a vehicle that are coming in the today's market are equipped with electronic systems. For example: The Fuel injection systems for cars rely on electronic components to provide the engine with the right amount of fuel. Likewise, safety systems also rely heavily on electronic circuits to provide optimum safety to the occupants of a car in the event of a crash. Braking systems also depend on electronic components like the anti-lock braking system (ABS). Without the aid of electronic components, even high quality parts like brake components will not perform the best of their capabilities. Therefore, the use of electronics in automobile industry also reduces manufacturing costs since human errors are very much avoided. In the automotive industry, the introduction of luxury car features also increased the need for specialized electronic components. The popularity of hybrid vehicles like the popular Toyota Prius also made the demand increase. Electronic components are needed on hybrid vehicles to facilitate the smooth change of power from engine to

electric motor muscle. In cars, like human brain the ECU (**Engine Control Unit**) is the brain of cars. The ECU plays an important role in the performance of the engine of a car's fuel injection system. In this paper, in part first we discuss about automobile industry. In second part we highlight the role of electronics and their applications in automobile. In third part we explain the working of ECU that are used in cars and how the ECU controls for a variety of systems and advantages of ECU. In this section we also explain the luxury car segment using engine control unit. In part fourth we explain the some new innovations in automobile industry.

II. I AUTOMOBILE

"Auto" means "automatic" and "mobile" means "moving". Basically automobile stands for automatic moving machine. Was invented to make life of people comfortable and luxurious. Automobiles are used to transport people and items from one location to another location. Automobiles are powered internal combustion engine. Automobiles generally use gasoline to fuel internal combustion engine but with the advancement of technology car designers led to development of cars work on electricity or now even water.

II.II. INDIAN AUTOMOBILE INDUSTRY

The automobile industry in India is one of the largest automobile industry in the world with annual production of 23.37 million vehicles. India is a prominent auto exporter in the world and has a strong export growth in the near future. Several initiatives have been taken by the government of India and major automobile companies in Indian market are hoping and working hard to make India a leader in automobile market.

Today the Indian roads are full of two wheelers, four wheelers. Traffic jams are day to day scenes; this is all due to the automobile industry flourishing on Indian grounds. Today each and every Indian family own a car and those who don't have a car they dream of a car. This is all due to the facilities and luxury provided by the automobiles. Indian automobile market is growing bigger and larger day by day. It is establishing its roots in small cities, towns and villages. Production, sales, export and import of automobiles is increasing each and every day.

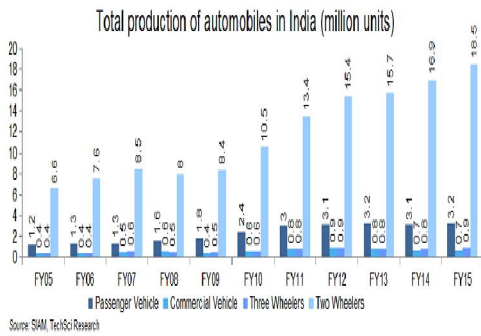

Fig.-1: Graph shows the total production of automobile in India

Source: <http://www.ibef.org/industry/india-automobiles.aspx>

I.III. HISTORY OF INDIAN AUTOMOBILE INDUSTRY

The automotive industry in India is one of the largest in the world with an annual production of 23.37 million vehicles in 2014-15. India is also a prominent auto exporter and has strong growth expectations for near future.

In 1897, the first car ran on an Indian road. Through the 1930's, cars were imported only, and in small numbers.

The first automotive industry of India emerged in 1940's. Hindustan Motors was launched in 1942, followed by premier in 1944, building Chrysler, Dodge and Fiat product respectively. Mahindra and Mahindra were established by two brothers in 1945, and began the assembly of Jeep CJ-3A utility vehicle. Following independence in 1947, the Government of India and the private sector launched efforts to create an automotive-component manufacturing industry.

1947-1970

- The 1949 Hindustan 10 built by Hindustan Motors under license from Morris motors UK.
- Hindustan Ambassador dominated India's automotive market from the 1960's until the mid-80's and was manufactured till 2014.
- Fiat 1100 D, built under license by Premier Automobiles later known as Premier Padmini was the Ambassador's only true competitor.

After 1970, with restrictions on the import of vehicles, automotive industries started to grow; but the growth was mainly driven by tractors, commercial vehicles and scooters. Cars still remain a luxury item. However by the 1980's the automotive market was still dominated by Hindustan and Premier. During the 80's, a few competitors began to arrive on the scene.

1984-1992

Maruti 800, a small city car that was manufactured by Maruti Suzuki in India from 1983 to 2013. Widely regarded as most influential automobile in India, about 2.87 million 800s were produced during its course of which 2.66 million were sold in India itself. With over 30 years of production, Maruti 800 remains the second longest production car in India, next only to Hindustan Ambassador.

Eventually multinational automakers, such as Toyota and Suzuki of Japan Hyundai of South Korea were allowed to invest in Indian market.

In 2008, South Korean multination Hyundai Motors alone exported 240,000 cars made in India. Nissan Motors plans to export 250,000 vehicles manufactured in its India plant by 2011. Similarly, US automobile company, General Motors announced its plans to export about 50,000 cars manufactured in India by 2011.

In September 2009, Ford Motors announced its plans to setup a plant in India with an annual capacity of 250,000 cars.

In recent years India has emerged as a leading sector for the manufacture of small cars. Hyundai, the biggest exporter from the country, now ships more than 250,000 cars annually from India. Nissan, Maruti Suzuki, TATA, Mahindra and Mahindra manufacture and exports cars to Asian, African and European markets. While the possibilities for the Indian automobile industry are impressive, there are challenges that could affect the future growth.

II. USE OF ELECTRONICS IN AUTOMOBILES

Electronics are replacing mechanical technology in automobiles. The high-tech systems of electronics were first introduced in 1980s, and today, auto electronic systems and engine computers are controlling almost all the functioning of the automobile from sensors to driver assistance. These electronic devices have an obvious effect on safety. Adaptive Cruise Control, which slows down the vehicle down if another vehicle is detected in front of it. Lane Assist system which warns the driver when he or she is leaving the lane without signaling etc.

Electronics denotes a broad engineering field that covers subfields such as analog electronics, digital electronics, consumer electronics, embedded systems and power electronics.

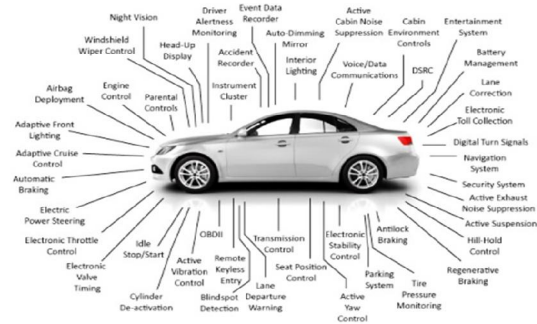

Fig.-2: shows the use of electronics in automobiles

In today's scenario the Automobile industry is also making great use of Embedded Systems. Embedded Systems consists of hardware and software designed for control and access of data. In Embedded Systems it includes a controller just as brain. This controller chip can be a PIC microcontroller, 8051 controller, etc. Today Embedded System applications are popular in navigation systems in automobiles and aircrafts, intruder alarm system etc.



Power electronics can be defined as the branch of electronics dealing with control and conversion of power. Power electronics is an application of solid-state electronics. It is basically the study of switching electronic circuits in order to control the flow of electrical energy. Power electronics is the technology behind switching power supplies, power converters, power inverters, motor drives etc. There are many applications of power electronics in today's automotive industry. Power electronics play a major role in controlling automotive electronics. Automotive electronics include modern electric power steering, HEV main inverter, central body control, braking system, seat control and so on.

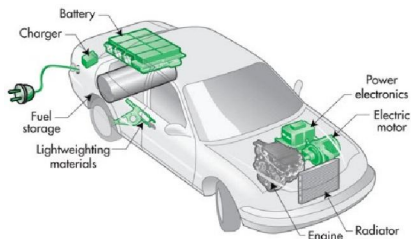

Fig.-3: figure shows the use of power electronics in automotive applications

Source: <https://www.elprocus.com/power-electronics-in-automotive-applications/>

III. APPLICATIONS OF ELECTRONICS IN AUTOMOBILE

1. NAVIGATION SYSTEM IN CAR: This navigation system consists of Embedded circuitry built with a GPS receiver, a Gyroscope, a DVD-ROM, main controller and a display systems. The GPS receiver receives the current longitude and latitude values that are compared with the stored map. The Gyroscope and other sensors provide the road direction and speed. From all the information gathered at the main controller, the display systems display a navigation or route map of the destination in the display screen [1].

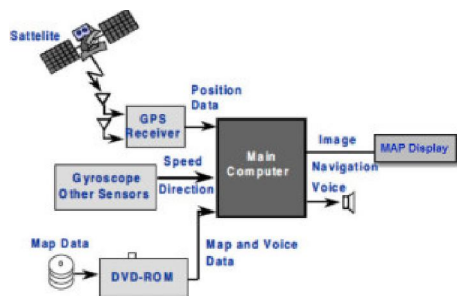

Fig.-4 : Block diagram of Embedded Navigation System in a car

Source: <https://www.edgefx.in/importance-of-embedded-systems-in-automobiles-with-applications/car>

2. EMBEDDED RAINING SYSTEM: In this system, an optical sensor is provided on a small area of front windshield glass. This optical

sensor is placed at an angle to emit the infrared light which then reads amount of light by when the light is reflected back. The light is reflected in cases where the windshield is wet or dirty. Thus the optical sensor determine necessary speed and frequency of windshield wiper depends on reflected light into sensors.

3. ANTI-LOCK BRAKING SYSTEM: Anti-lock brake system is used in automobiles to avoid the vehicles from skidding especially in a slippery road. This system allows the wheels of the vehicle to have better contact with the road. This system basically consists of sensors to track the speed, valves, pump and a controller. There is an electronic control unit in the system which monitors the movement of the wheel. If a wheel in the automobiles goes slow, the speed sensors will tell the valves to reduce pressure to the brake and thereby the wheel turns faster. On the other hand, if the wheel goes faster, the pressure to the wheel is increased thereby slowing down the wheel.

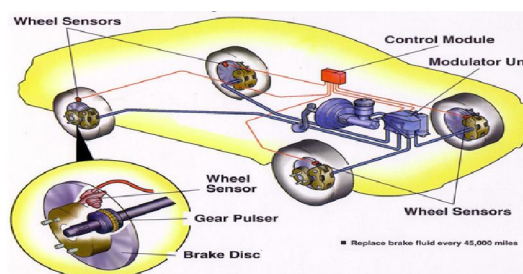

Fig.-5: use of anti-lock braking system in cars

4. DRIVE BY WIRE: This system helps to replace the mechanical systems in automobiles with electronic systems using actuators and HMI (human machine interfaces). Components of the automobiles like belts, steering column, pumps, coolers, vacuum servos and master cylinders, hoses, intermediate shafts are eliminated.

5. ADAPTIVE CRUISE CONTROL: Embedded System in Automobiles has made the driverless car a big reality. "Google Driverless car is an example". Adaptive cruise control is now widely used in automobiles to make a minimum distance between vehicles on high traffic highways and in areas of busy traffic. When the traffic congestion goes down, adaptive cruise control helps to change the speed of the vehicle using the braking system. It slows down the speed of the vehicle if another vehicle is detected in front of it and reduces the chances of collision.

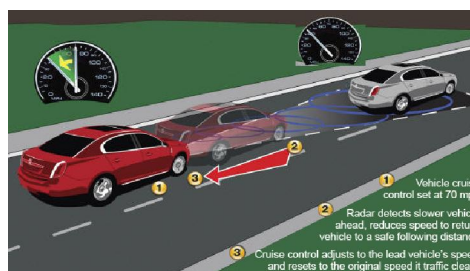

Fig.-6: Embedded Systems in Automobiles - Adaptive Cruise Control



Each automobiles having the adaptive cruise control will be having radar as a transceiver fixed on it to know the distance and speed of the vehicles in the path. The computer associated with the ACC unit helps to control brake and throttle of the automobiles.

6. AIR BAG CONTROL SYSTEM: Airbags are generally designed to inflate in the cases of frontal impacts in automobiles. When the collision process happens, an electric current is sent to the ignition system. This electric current keeps on heating the filament and thereby ignites the capsule which in turn ignites the pellets and generate the gas. When the gas expands, the air bags also get inflated. All this happens within a time limit of 0.1 sec.

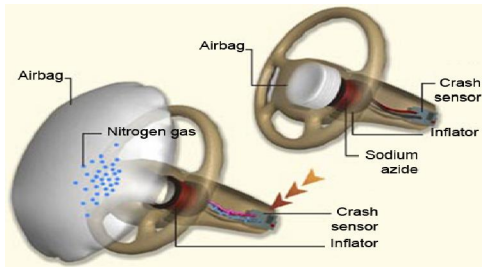

Fig.-7: Air Bag Control System

7. SILICON BASED DUAL CHANNEL MOSFET: In our day-to-day life, we frequently observe heat radiating from car engine after the car has been driven for a certain distance. This is due to power train systems of automotive electronics with an engine or internal combustion or motor as one of the subsystems operating with high temperature exceeding 125degree Celsius. Applications of power electronics with components such as silicon based power MOSFET and IGBT that are used as power electronics switches in the power train system of automotive electrical and electronics systems for reducing the overall size, and also for managing thermal issues in which a high power of KW range is being used for improving fuel efficiency.

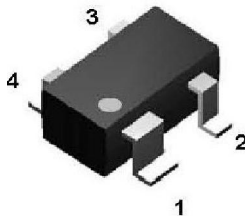

Fig.-8: Silicon Based Dual Channel MOSFET

8. SILICON CARBIDE CHIPS: Limitations can be overcome by using a silicon carbide chips with a high-operating temperature that allow placing the circuit near high temperature location. It has two or three times higher thermal conductivity than silicon, which will eliminate need of big copper blocks and water jackets. It has high breakdown voltage. It is also capable of switching at high frequencies with very less power loss which makes the overall size of circuitry very small.



Fig.-9: Silicon carbide chips

9. VARIOUS SENSORS ARE USED IN CARS:

- AIR FLOW METER: measure air flow i.e. how much air is flowing through a tube. It does not measure the volume of the air passing through the tube; it measures the mass of air flowing through the device per unit time.
- AIR FUEL RATIO METER: monitors the air-fuel ratio of an internal combustion engine. It reads the voltage output of an oxygen sensor, sometimes also called lambda sensor.
- BLIND SPOT SENSOR: vehicle based sensor device that detects other vehicles located to the driver's side and rear. Warnings will be visual, audible vibrating or tactile.
- CRANKSHAFT POSITION SENSOR: a crank sensor is an electronic device used in an internal combustion engine to monitor the position or rotational speed of the crankshaft.
- DEFECT DETECTOR: used on rail roads to detect axel and signal problems in passing trains.
- ENGINE COOLENT TEMPERATURE SENSOR: ECT used to measure engine temperature.
- HALL EFFECT SENSOR: Used to time the speed of wheels and shafts, for example speedometer.
- KNOCK SENSOR: detect detonations in internal combustion engines.
- MAP SENSOR: used as route sensed sensor for correct directions.
- MASS AIR-FLOW SENSOR: MAF tells the ECU the amount of air entering the engine and the amount of air required.
- OXYGEN SENSOR: senses the amount of oxygen is there in the exhaust.
- PARKING SENSOR: tells about the unnoticeable obstacle to the driver during parking.
- RADAR GUNS: it detects the speed of the other object near the vehicle.
- SPEEDOMETER: used to measure the instantaneous speed of the vehicle.
- THROTTLE POSITION SENSOR: used to detect if there is any throttle in internal combustion engine.
- TIRE PRESSURE MONITOREING SENSOR: for measurement of pressure inside the tire.
- TORQUE SENSOR: measures torque of rotating systems if the car.



- TRANSMISSION FLUID TEMPERATURE SENSOR: temperature of transmission fluids are measure by this sensor. If temperature of fluid increases vehicle start gestating up.
- INPUT SPEED SENSORS: ISS used to measure rotating speed of input shaft or torque converter.
- VARIABLE RELUCTANCE SENSOR: used to measure position and speed of the metal parts moving in a vehicle.
- WATER SENSORS: how much water is there or required in fuel is detected by this sensor.
- WHEEL SPEED SENSOR: it reads the speed of the wheel and rotation of wheel.

10. SOME ELECTRONICS PARTS USED IN CAR'S: The vehicle industry is a growing rapidly with the use of electronic devices such as computers, sensors or actuators etc. The sensors provide data to the computer, which in turn based on the received data managed by mechanical processes through actuators. The computer has become an essential part of modern cars. These computers are adequately protected from the heat, dust, water and moisture; environment that is not even close to a home computer environment. Some electronics parts used in car's are shown in fig.-10.



Fig.-10: Shows some electronics parts used in car's

III. ENGINE CONTROL UNIT (ECU) IN CARS

Engine control unit or it is also called Engine Control Module are basically electronic control unit that consists of a system used to control actuators connected in series on internal combustion engine and increases the efficiency of the engine. If a car engine compare with human body, the ECU is basically a small computer, the pistons of car would be the heart, the headlights would be the eyes, and the engine control unit (ECU) would be the brain. Several sensors are used that provide the ECU with maintenance information. The ECU uses these sensor readings to adjust engine actuators. It controls things like spark timing and the fuel injectors, which can directly affect power output, fuel economy, and emissions. Electronic control is the key to the overall increase in automotive performance over the last few decades. It gets around the fixed nature of traditional mechanical control systems by taking them out of the equation and letting a computer program determine everything. The big advantage is ECUs not only vary the

timing but also the amount of fuel and strength and duration of the spark. This helps ensure complete combustion, which increases fuel economy and minimizes emissions[2]. Thus the **Engine Control Unit (ECU)** plays a major role in the performance of the engine of a car's fuel injection system. The ECU has a high level of sophistication, it is not a jumble of belts and wires at all. It uses **microprocessors and sensor data that can be processed to perform in real time.**

In mid 1980s analog designs were used to measure parameters of the engine. Now a days Modern ECUs are available. These ECU uses a microprocessor which collects the input from the engine in real time. It has both hardware and software components attached with the engine, where hardware consists of Printed Circuit Board (PCB) and a thin laminated substrate. A PCB has a microcontroller chip present on it. The software is stored on the chips of PCB. Hence the system is reprogrammable by replacing chip or uploading update code. Modern ECU also include features such as transmission control, antitheft control, cruise control.

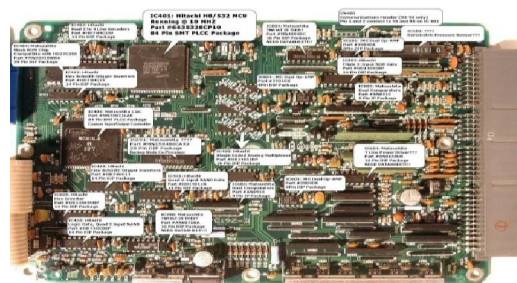
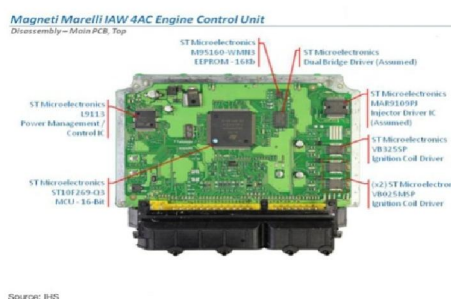

Fig.-11: Modern ECUs

Source: <http://www.theautomotiveindia.com/forums/attachments/ownership-reviews/140395d1405365065-my-fluidic-verna-1-6-crdi-sx-o-2014-2014-05-30-1541.jpg>



Source: BHS

Fig.-12: Engine Control Unit

III.I. THE ECU CONTROLS FOR A VARIETY OF SYSTEMS

The ECU is also called car computer, provides controls for a variety of systems within the engine.

1. AIR FUEL RATIO: Most modern engines uses some type of fuel injection to ensure that the air to fuel mix is the proper ratio. The ECU



determines the amount of fuel to inject based a number of sensor readings. The throttle position sensors indicate how much the throttle pedal is pressed. The mass flow sensor measures the amount of additional air flowing into the engine. The engine coolant temperature sensor measures whether the engine is warmed up. If the engine is still cool, additional fuel will be injected. Mixture control of carburetors with computers is designed with a similar principle, but a mixture control solenoid or stopper motor is incorporated in the float bowl of the carburetor.

2. IGNITION TIMING: Within a spark ignition engine, a spark is required to start the combustion in the combustion chamber. The exact timing of the spark can be adjusted by the ECU to ensure improved power and economy. Knocks, a condition that can be destructive to engines, can be detected by the ECU and fixed by delaying the timing of the spark to prevent the ignition timing from being too early for the compression stroke. The ECU will sometimes downshift into a lower gear to eliminate the knock, when the car is running at lower rpm.

3. IDLE SPEED: A crankshaft position sensor can relay information to the ECU in regards to idle speed. The sensor has an importance in functions of engine timing, such as fuel injection, spark events, and valve timing. A programmable throttle stop or an idle air bypass control motor is used to control idle speed. The idle speed control needs to anticipate the engine load at idle. Variations in load can be caused by the air conditioning or heating systems, the power brake or steering systems, and the electrical charging and supply systems. Other factors that affect engine load and idle speed are life and duration of the camshaft, engine temperature, and transmission status.

4. VARIABLE VALVE TIMING: In a variety of engines, the ECU controls the engine cycle when the valves open. At higher speeds, the valves are opened sooner than at lower speeds. When the valves are open at higher speeds, the air flow is optimized into the cylinder. This increases the power and economy of the engine.

5. ELECTRONIC VALVE CONTROL: The ECU in some cars, such as mild hybrid-electric drive cars, can replace the camshaft by providing full electronic control of the intake and exhaust valve opening as well as the valve closing and area of the valve opening. Electronic valve control can reduce fuel consumption by as much as 15 percent, while improving torque and horsepower. The ECU operates valves that are opened by hydraulic pumps in cars such as the Alfa Romero MiTo. The elimination of the camshaft also significantly reduces the weight of the car.

III.II.PROGRAMMABLE ECUs: Programmable ECUs are programmed by the user and do not have fixed behaviors. They are required in cars that have significant aftermarket modifications, such as the addition of a turbocharger, intercooler, or alternate exhaust system after conversion to alternative fuel. The following table shows some of the parameters that a programmable ECU can control:

Table-1: Table shows some of the parameters that a programmable ECU can control:

| Parameter Controlled by ECU | Purpose |
|--|--|
| Amount of fuel injected into each cylinder | Allows engine to adjust to rpm and throttle position |
| Ignition timing | Provides point in engine cycle where the spark plug should fire with each cylinder |
| Revolution limit | Define maximum RPM for the engine |
| Water temperature correction | Provides additional fuel for cold engine |
| Transient fueling | Adds specific amount of fuel when the throttle is applied |
| Low fuel pressure modifier | Increases injector fire time to compensate for a change in fuel pressure |
| Closed loop lambda | Monitors lambda probe and changes air:fuel ratio |

As one can see from the table, there are many engine calibrations that can be controlled via the ECU. The ECU is generally mapped using a laptop computer connected via a serial or USB cable, while the engine is running[3].

III.III. ADVANTAGES OF THE ECU

ECU is the all part of an engine management system that allow for a much better fuel economy and a more responsive performance. Therefore, smaller amount of emission coming from the vehicle, which is great for the environment. The ECU permits processing of all the information that is received by the engine with the sensors. The car responds far better and much quicker because of ECU. The size of ECU is incredibly small, and it has the ability to control all the major working parts of the engine, and deliver the kind of performance that makes driving more pleasure than a challenge.

III.IV.LUXURY CAR SEGMENT USING ENGINE CONTROL UNIT

1. HYUNDAI VERNA 1.6 CRDI (common rail direct injection) SX: This technology consist of a common "fuel-rail"; which supply fuel to injectors. The engine of Hyundai is two types: petrol engine and diesel engine. The Verna might be available in 1.4 L petrol engine. This



engine is sufficient to produce 105 bhp as maximum power. The maximum torque generated by this petrol engine might be 135 Nm. Verna may be accessible in 1.5 L petrol engine. This engine is adequate to create 121 bhp as most extreme torque created by this petrol engine may be 155 Nm .

The diesel engine of VERNA 2017 might be available in 1.4 L diesel engine. This engine is sufficient to produce 89bhp as maximum power. The maximum torque generated by this engine might be 220Nm. Verna may be accessible in 1.6 L diesel engine. The engine is adequate to create 125 bhp as most extreme power.

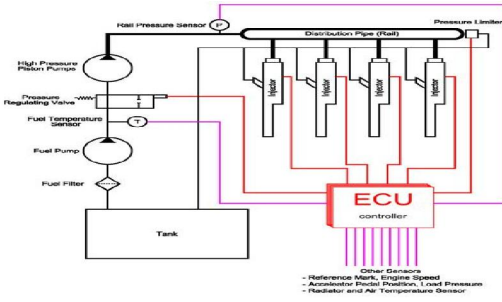

Fig.-13: Engine Control Unit of CRDI

Source: <http://2.bp.blogspot.com/iprossb4eys/Ui3agqu0AUI/AAAAAAAAA0/NK-qD1yroMk/s1600/CRDI.JPG>

2. RENAULT DUSTER: The Renault Duster is also available in both petrol and diesel engine options while the 1.6 L petrol engine has the capacity to churn out a power of 104 ps and the peak torque of 148 Nm, the diesel 1.5 liter turbocharged diesel engine offers two state of tune. The base diesel variant returns a power of 85ps and 200Nm of maximum torque whereas the high end variant of the same gives a power of 10 ps and 245Nm of maximum torque.

3. HONDA CITY: The HONDA CITY uses two engines: i-DTEC and i-VTEC (Variable Valve Timing and Lift Electronic Control). The 1.5L i-DTEC gives a high mileage of 26.0 kmpl and maximum power of 100 ps. It is an aluminium construction that runs on a low friction technology and thus, it has perfect efficiency. The 1.5L i-VTEC petrol engine strikes a perfect balance by providing an impressive power of 119 ps combined with mileage of 17.8 kmpl in the manual transmission.



Fig.-14(a): Image of i-VTEC engine

Source: https://en.wikipedia.org/wiki/Honda_advanced_technology#/media/File:Honda_Hybrid_System_02.JPG



Fig.-14(b): Image of 1.5L i-VTEC petrol engine

Source: https://www.hondacarindia.com/brv/?utm_source=Google&utm_medium=CPC&utm_campaign=BRV_Brand&qclid=CID11rmO388CFdWJaAodUFsM

RA



Fig.-15(a): Image of 1.5L i-DTEC DIESEL ENGINE

Source: https://www.hondacarindia.com/brv/?utm_source=Google&utm_medium=CPC&utm_campaign=BRV_Brand&qclid=CID11rmO388CFdWJaAodUFsM

RA



Fig.-15(b): Image of 1.5L i-DTEC DIESEL ENGINE

Source: <https://engweekly.files.wordpress.com/2012/03/honda-1-6-liter-i-dtec-turbodiesel-engine.jpg>

4. HYUNDAI CRETA: Hyundai CRETA is offered in both petrol and diesel engines in India. CRETA gets 1.6L CRDI diesel engine that is tuned to pump out 128ps of power and 260Nm of torque and 1.4 litre CRDI diesel motor. The engine of CRETA comes mated to 6-speed manual transmission and the 1.6 litre CRDI diesel also gets a 6-speed automatic gearbox.

5. HONDA BRV: It is offered in both petrol and diesel engines. In Honda's revolutionary 1.5L i-DTEC diesel engine offering mileage of 21.9 km/l and an exhilarating power of 100 ps. Honda's 1.5L i-VTEC petrol engine gives a fierce combination of high power output and class



leading fuel efficiency, offering mileage of 15.4 km/l and an exhilarating power of 119 ps.

IV. SOME NEW INNOVATIONS IN AUTOMOBILE INDUSTRY

1. Google Driverless Cars: One of the new innovations in automobile industry is the Google Driverless Cars. Google's driverless car has eight sensors. It uses GPS to match their position with customized Google maps. This allows the cars to select a starting point and an end point, as well as to choose the best routes to take. With the help of Radar technology, in the front and back of the cars keep track of other vehicles on the road. The LIDAR (Light Detection and Ranging) sensor is also used. This is a remote sensing method that uses light in the form of a pulsed laser to measure ranges to the Earth. These light pulses combined with other data recorded by the airborne system generate precise, three-dimensional information about the shape of the Earth and its surface characteristics. It rotates 360 degrees and detects the distance between the autonomous vehicles and surrounding objects. A video camera behind the front windshield is able to read road signs and traffic lights.



<http://economictimes.indiatimes.com/top-10-innovations-in-automobile-industry-in-2014/articleshow/45688058.cms>

This new technology will not only be a breakthrough in tough traffic congestion but sensing technology can also increase road safety.

2. Automated Manual Transmission (AMT): AMT is an electro-hydraulic mechanism for automating manual transmission, which derives from Formula 1. It has two systems: hydraulic system and an electronic system. The electronic transmission control unit helps in engaging and disengaging the clutch and gear through an electronic actuator. It also has a sports mode, which enables drivers to move to the manual shifting of gear to increase and decrease the gear ratios with plus and minus either through gear knob / joystick or the steering. In India, AMT is currently available in three cars — Celerio, Alto K10 and Tata Zest [4].

3. V2V Communications: V2V (vehicle-to-vehicle) is the communication technology for light vehicles. This technology would allow vehicles to "talk" to each other and ultimately avoid many crashes altogether by exchanging basic safety data, such as speed and position, ten times per second, to improve safety.

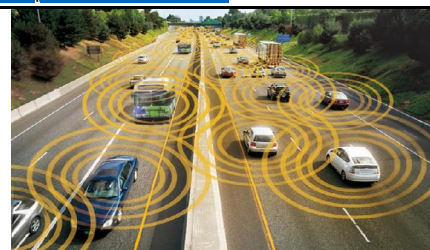

Fig.-16: Image of V2V Communications

V2V communication technology uses 'ad hoc network', where every car is free to associate with any other car available in the network and share equal status. V2V, which is also known as VANET (vehicular ad hoc network), is a variation of MANET (mobile ad hoc network). Many automobile manufacturers including are BMW, Audi, Honda, General Motors, Volvo and Daimler working and developing this technology to improve safety, overcome blind spots and avoid accidents[4].

4. Pre-Collision Technology: This technology helps the driver to detect blind spots, this technology also alerts the driver when he/she is not paying attention on the road. And if the driver falls asleep and does not respond to the warning, then the system applies the brakes on its own. The driver assist system has two types of sensors.



Fig.-17: Image of Pre-Collision Technology used in cars

One is millimetre-wave radar located inside the front grille, and the other is a monocular camera mounted on the upper, inside part of the windshield. Its collision mitigation braking system delivers an audio and visual warning when there is a risk of a head-on collision. If the driver fails to react, the car will automatically begin breaking itself to prevent or reduce the severity of a crash [4].

4. Bio Monitoring: It will be there in cars for any health crises diagnosis. It will include passive alcohol detector for safety parameters and if it will go far your vehicle will command you that your body weight is killing is fuel economy.

5. Partial Autonomy: Also considered self driving system it will be equipped with super cruise control, automatic accelerator, brake, steering etc. If any obstacle is detected car will automatically lower down its speed and will reduce the chance of collision by itself.



6. LCD Instrument: Future cars will go to be fully equipped with LCD over.

Source: <http://singularityhub.com/2009/07/23/claytronics-or-gershenfeld-why-youll-be-able-to-make-almost-anything/>



Fig.-18: figure shows the use of LCD Instrument in cars

7. Uses of Apps in Cars: These include map, Pandora, weather report, Bing, I-heart radio, fuel prices.



Fig.-19: figure shows the uses of APPS in cars

8. Natural Voice: In future car driver will going to know that cars are smarter than there smart phone. There will be a button on steering wheel which will turn on voice command system and we can have natural conversation with our vehicle. The more natural the car conversation less there will be any chances of accidents.

9. Use of Claytronics in Cars: Claytronics is a future technology that combines Nano-scale particles and computer technology to create individual nanometer-scale computers called Claytronics atoms or CATOMS, which can interact with eachother to form adjustable with touch 3D objects that a user can interact with.

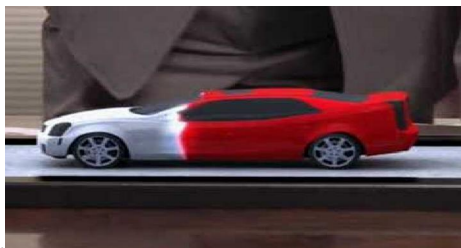

Fig.-20: figure shows the uses of Claytronics in cars

V. CONCLUSION

The ECU is one of the biggest improvements in automobile industry. By taking advantage of electronics, car manufacturers have been able to provide enhanced engine precision. With the help of ECU, cars to be more fuel efficient and provide improved handling. The ECU provides control to the air: fuel ratio, idle speed, and variable valve timing, among other functions. Programmable ECUs can provide an additional range of functions, including ignition time, rpm limits, and transient fueling etc. Thus the ECU plays a major role in the performance of the engine of a car's fuel injection system. It uses **microprocessors and sensor data that can be processed to perform in real time.**

REFERENCES

- [1] <https://www.edgefx.in/importance-of-embedded-systems-in-automobiles-with-applications/>
- [2] <http://www.ebay.com/gds/What-Is-a-Chipped-ECU-/10000000177633633/g.html>
- [3] <http://www.ebay.com/gds/What-Is-an-ECU-/10000000177635225/g.html>
- [4] <http://economictimes.indiatimes.com/top-10-innovations-in-automobile-industry-in-2014/articleshow/45688058.cms>

Author's Details

Vijay Laxmi Kalyaniis Head of the department (HOD) of ECE in GWEC, Ajmer. She has attended and organize various workshops, conferences, FDP, STC and also published many research papers in Various Referred Journals, and Conferences Proceedings, She is Faculty coordinator of EESO and Member of IAENG.

Miti Bhatnagar is a B.Tech (III-year) student of Electronics and Communication Engineering in GWEC, Ajmer. She is a student coordinator of EESO and a Member of ISTE.

Lavina Shivnani is pursuing B.Tech. (III-year) in Electronics and Communication Engineering in GWEC, Ajmer.

Era Verma, is pursuing B.Tech. (III-year) in Electronics and Communication Engineering in GWEC, Ajmer.