

QUALITY IMPROVEMENT THROUGH AUTOMATION OF PRODUCT DESIGN PROCESS IN A MANUFACTURING ORGANIZATION

M.T. Sawant ¹⁾
J.S. Bagi ²⁾

1) Asst. Professor,
Mechanical Engineering,
S.S.P.M. C.O.E, Kankavli,
Maharashtra, India,
mandar_sawant81@
yahoo.co.in

2) Associate Professor,
Production Engineering, K.I.T.'s
C.O.E. Kolhapur, Maharashtra,
India, jaysbagi@gmail.com

Abstract: This paper focuses on the use of CAE for improving some of the quality dimensions of the business process, such as reliability and quick response to market. To establish this, a software based approach is developed coupled with interface with CAD environment by using RAD technology. This system would help enable the rapid design and generation of model of a critical component like the rotor of a submersible pump. The parametric design of the critical component i.e. motor is established and software solution for the same is developed. The dimensions of the rotor are critical and interdependent. The flexibility thus obtained using the software will facilitate fast design of a submersible pump. This case study has been carried at M/s. Vira Pumps, Kolhapur, India. The company manufactures and exports different types of submersible pumps and motors to many countries. The company is working in this area from last 35 years. Being an ISO 9001 certified company there is an on going continual improvement process in all its areas of operation. ISO 9001:2008 specifies requirements for a quality management system where an organization needs to demonstrate its ability to consistently provide product that meets customer requirements, and aims to enhance customer satisfaction through the quick reply and improved reliability of the product with CAE.

Keywords: CAE- Computer Aided Engineering, RAD- Rapid Application Development

1. INTRODUCTION

The effective deployment of ISO 9000 quality management system (ISO 9000 QMS) has been widely recognized in recent years as a means of building sustainable competitive advantage and thereby enhancing firm performance. ISO 9000 standards are internationally recognized and designed to demonstrate that the supplying organization has achieved a basic level of quality by the formalization and documentation of its quality management system.[1]

For this study a number of recent publications related to the effects of ISO 9000 quality management system were reviewed. Australian manufacturing companies found that certification is likely to lead to both actual and perceived quality improvements, as well as overall improvements in organizational performance. [2] It is proposed that ISO 9000 certified companies in the US industry expect their quality systems will lead to improving product design, process design, product quality, public image and supplier relations.

A submersible pump is a device which has a hermetically sealed motor close-coupled to the pump body. The whole assembly is submerged in the fluid to be pumped. The main advantage of this type of pump is that it prevents pump cavitation, a problem associated with a high elevation difference between pump and the

fluid surface. Submersible pumps push water to the surface as opposed to jet pumps having to pull water. Submersibles are more efficient than jet pumps.

A system of mechanical seals are used to prevent the fluid being pumped from entering the motor and causing a short circuit. The pump can either be connected to a pipe, flexible hose or lowered down guide rails or wires so that the pump sits on a "ducks foot" coupling, thereby connecting it to the delivery pipe work.

Submersible pumps are found in many applications. Single stage pumps are used for drainage, sewage pumping, general industrial pumping and slurry pumping. They are also popular with aquarium filters. Multiple stage submersible pumps are typically lowered down a borehole and used for water abstraction or in water wells.

Special attention to the type of Submersible Pump is required when using certain types of liquids. Submersible Pump's commonly used on board naval vessels cannot be used to dewater contaminated flooded spaces. These use a 440 volt A/C motor that operates a small centrifugal pump. It can also be used out of the water, taking suction with a 2-1/2 inch non-collapsible hose. The pumped liquid is circulated around the motor for cooling purposes. There is a possibility that the gasoline will leak into the pump causing a fire or

destroying the pump, so hot water and flammable liquids should be avoided.

The Submersible Pump system consists of a number of components that turn a staged series of centrifugal pumps to increase the pressure of the well fluid and push it to the surface. The energy to turn the pump comes from a high-voltage (3 to 5 kV) alternating-current source to drive a special motor that can work at high temperatures of up to 300 °F (149 °C) and high pressures of up to 5,000 psi (34 MPa), from deep wells of up to 12,000 feet (3.7 km) deep with high energy requirements of up to about 1000 horsepower (750 kW).

Submersible Pumps have dramatically lower efficiencies with significant fractions of gas, greater than about 10% volume at the pump intake. Given their high rotational speed of up to 4000 rpm (67 Hz) and tight clearances, they are not very tolerant of solids such as sand.

2. CASE STUDY AT VIRA PUMPS

2.1 Brief Introduction of company

This case study has been carried out at M/s. Vira Pumps, Kolhapur, India. The company manufactures and exports different types of submersible pumps and motors to many countries. The company is working in this area from last 35 years. The company produces various variants and models based on different specifications and customized requirements.

Being an ISO 9001 certified company there is an on going continual improvement process in all its areas of operation. The organization has already established software based submersible motor design system, long back in the year 2003. The software is capable to design any single phase or three phase submersible motor ranging from 0.5 to 5HP.

The organization has a total in-house design department engaged in the design of the following,

- 1) Stator design
- 2) Rotor design
- 3) Bearing bush design
- 4) Thrust bearing design

Only the electrical design is done using the in-house software whereas design of all remaining components still till today is done manually. This includes lots of manual calculation followed with lots of paperwork not only to verify or validate the design but also to aid the documents procedure as per establish QMS. The surveillance audit of the company was conducted recently.

Based on this recommendations were made by auditors to also have similar software like that of electrical design software. They recommended that this would facilitate the design procedure much faster.

2.2 Quality Objectives of the Company

- 1) Total Customer Satisfaction.
- 2) Ensure Effective Supply Chain Management.
- 3) Establish Proper Design Process across the Organization.
- 4) Enhance Human resource utilization with aid of modern technology.
- 5) To evolve as responsible corporate sector, nurturing human values and concern for society and the environment.

Being an ISO 9001 certified company there is an on going continual improvement process in all its areas of operation. ISO 9001:2008 specifies requirements for a quality management system where an organization needs to demonstrate its ability to consistently provide product that meets customer requirements, and aims to enhance customer satisfaction through the quick reply and improved reliability of the product.

In this paper automation of design process of submersible motor rotor is discussed

2.3 Rotor introduction

The function of a rotor is to transfer the power from a motor to impeller that rotates and throws the water upward. Thus, a rotor design is an essential part to pump design and construction. Rotor is combination of copper ring, balancing ring, shaft for journal bearing, thrust bearing plate, shaft for oil seal and couplings. The rotor nomenclature is shown in fig 1.

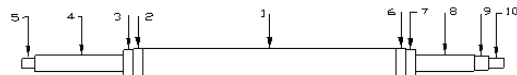

Notation	Description
1	Rotor [core part]
2	Copper ring
3	Balancing ring
4	Shaft for Journal bearing
5	Thrust bearing plate
6	Copper ring
7	Balancing ring
8	Shaft for Journal bearing
9	Shaft for Oil seal
10	Shaft for coupling

Fig. 1 Rotor nomenclature

2.4 Design considerations for Rotor

The rotor consists of a block of slotted laminations mounted on a shaft. The slots form a series of tunnels when the rotor is assembled. The tunnels are filled with aluminum, poured in the molten state. The bars, end rings and fan blades form one homogenous casting. In some motors copper bars and copper end rings are used, the former being brazed into the latter. The rotor slots are skewed so that a quieter operation is obtained.

Rotor is a common and important machine element. It is a rotating member, in general, has a circular cross-section. The rotor is supported on bearings and it rotates impeller for the purpose of water pumping. The rotor is generally acted upon by bending moment, torsion and axial force. Design of rotor primarily involves in determining stresses at critical point in the shaft that is arising due to aforementioned loading.

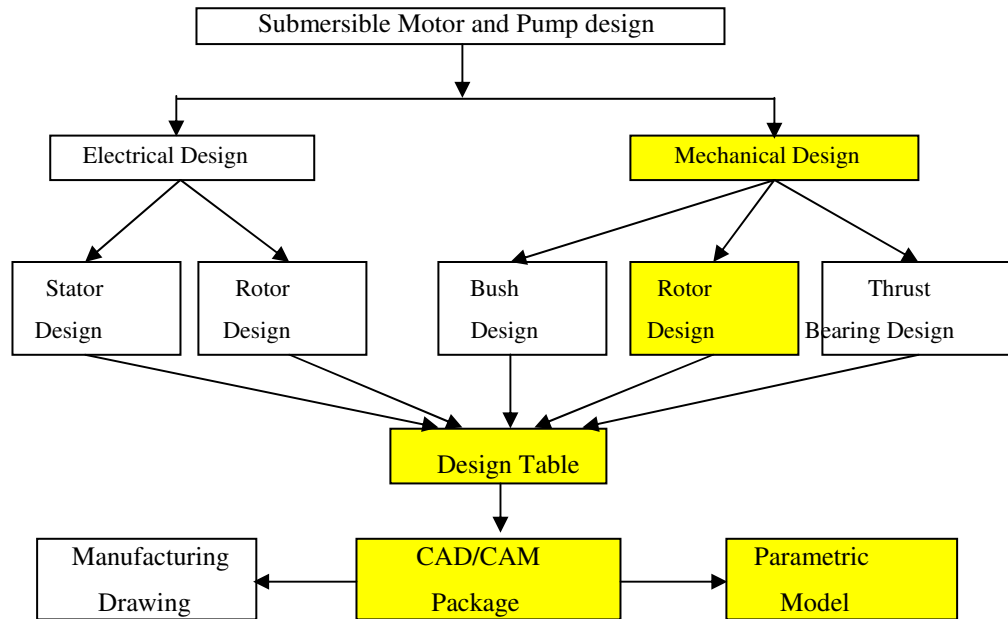

Fig.2 - Automation of Design system

2.5 Automation of Design system

The organization is already an ISO 9001 certified company with design as a main scope. Since the years they have only managed to develop a electrical design software where as all other design activity on a paper are mostly manually done. The various components which are required to design are tedious/lengthy and repetitive type.

Further at any time when there is a specific input by a customer then this process becomes very lengthy and there may be a danger of client loosing interest in the product. Also there is a huge amount of data correction factors, constants etc. which seems difficult to be kept at one place. So this calls for a well designed DBMS which will be integrated with some export design system. To have individual software for various components is vary difficult so a unit feature will be that single design software should be capable of designing the entire concerned component.

Such a proposed automation of such designed

software is represented in the block dia.shown in fig. both the electrical design and mechanical design are linked with each other. A purpose of this is both this modules will share some common input data i.e. they will access the same data base.

3. RAD LANGUAGES

Rapid Application Development is a software development methodology that involves techniques like iterative development and software prototyping. According to Whitten (2004), it is a merger of various structured techniques, especially data-driven Information Engineering, with prototyping techniques to accelerate software systems development.

In Rapid Application Development, structured techniques and prototyping are especially used to define users' requirements and to design the final system. The

development process starts with the development of preliminary data models and business process models using structured techniques. In the next stage, requirements are verified using prototyping, eventually to refine the data and process models. These stages are repeated iteratively; further development results in "a combined business requirements and technical design statement to be used for constructing new systems". RAD approaches may entail compromises in functionality and performance in exchange for enabling faster development and facilitating application maintenance.

3.1 DBMS

Initially I am using single user data base system which will use Microsoft Access as the back end where as the programming will be done in VB. NET.

VB.NET and C# (sharp) both share the common technology called Microsoft .NET framework. VB.NET which uses a basic language as platform or C# resembling C++ language both are OOP.

That means the following concepts are follow.

- 1) data encapsulation
- 2) data abstraction
- 3) polymorphism
- 4) Inheritance

I am proposing to use the VB.NET language because I have previous experience in its older technology i.e. VB 6 using VB. NET and firing SQL(Structured Query Language) queries. Now again referring to given block diagram if we see at the bottom a CAD/CAM package like Unigraphics , catia or solidworks will be having parametric model.

Parametric model is a model which is a fully constrained model whose dimensions are stored in a design table. Depending upon CAD/CAM software the design table may be either in MS Excel format, MS Access format or simply a some sort of text file.

3.2 Parametric modeling

A CAD modeling method uses parameters to define the size and geometry of features and to create relationships between features. Changing a parameter value updates all related features of the model at once.

Parametric modeling uses parameters to define a model (dimensions, for example). The parameter may be modified later, and the model will update to reflect the modification. Typically, there is a relationship between parts, assemblies, and drawings. A part consists of multiple features, and an assembly consists of multiple parts. Drawings can be made from either parts or assemblies.

Example: A shaft is created by extruding a circle 100 mm. A hub is assembled to the end of the shaft. Later, the shaft is modified to be 200 mm long (click on the shaft, select the length dimension, modify to 200).

When the model is updated the shaft will be 200 mm long, the hub will relocate to the end of the shaft to which it was assembled, and the engineering drawings and mass properties will reflect all changes automatically.

Examples of parameters are: dimensions used to create model features, material density, formulas to describe swept features, imported data (that describe a reference surface, for example).

Related to parameters, but slightly different are Constraints. Constraints are relationships between entities that make up a particular shape. For a window, the sides might be defined as being parallel, and of the same length.

Parametric modeling is obvious and intuitive. But for the first three decades of CAD this was not the case. Modification meant re-draw, or add a new cut or protrusion on top of old ones. Dimensions on engineering drawings were created, instead of shown.

Parametric modeling is very powerful, but requires more skill in model creation. A complicated model for an injection molded part may have a thousand features, and modifying an early feature may cause later features to fail. Skillfully created parametric models are easier to maintain and modify.

3.3 Design and Development of Parametric Rotor Design Software

The rotor is the most critical rotating element of a water cooled submersible motor. The dimensions of the rotor are very critical as it is where the couple will connect the motor unit to the pump unit. The most important parameter in the design of the Rotor is the Core length. The Core length will vary as the rating of the motor will change. All the other dimensions will remain unchanged provided that the other mating components are of the same size and type. The mating components are Motor Base, Lower Housing, Upper housing and Connecting piece.

If the manufacturer is strictly following the exact design of these above components or he is procuring or purchasing from the same supplier then he can design and establish the rotor dimension at one time only. This holds true also if the Core lengths for various rating motors are fixed and the manufacturer follows the mass production concept. We have established earlier that there has been a shift from Mass Production to Mass customization. The design of the motor has to be flexible as per the customer design. The Core length of the motor cannot be fixed and will vary as per the motor design required to meet the electrical input conditions. The Core length will ultimately be the one of the Trial Core length fixed by performing various combinations using the Expert Designer's Single Phase and Three Phase design procedure. So, each time a new design is established a new rotor design again has to be generated which would also accommodate the recommendation

made from the Journal design output.

By past experience it has been evident that if the rotor design or its dimensions are incorrect then :

1. The Rotors stamping length's center will not align with the Stator's center and thus the magnetic and electric conditions for the motor will not be met completely resulting decrease in the speed and torque requirements ultimately a faulty motor.
2. The motor cannot be assembled properly with pump unit as the axial play will be either to less or more thus affecting badly the pump performance.
3. Eventually if a pump by some means is coupled with a motor with a faulty rotor would result in failure (in sequence) Thrust bearing, Bearing bushes and ultimately the windings.

To address all these criticalities, the Parametric design of the rotor can only be the possible guideline to manufacture the rotor. The typical nomenclature of a rotor for parametric design is shown in figure 3 Further, it can be seen in figure 4 the arrangement of the rotor in

the submersible motor. The mating components viz Motor Base, Lower Housing, Upper housing and Connecting piece are shown in a 100 mm Submersible motor as well as in a 150 mm Submersible motor in Figure 4

Using Expert designer, we can effectively design such a rotor quite effectively and quickly. Firstly, we will see the design table for the rotor as shown in figure 6.

Cell B3 & C4 correspond to the diameter and Core length of the rotor which are the variables D1@Sketch1 and D1@Extrude1. Expert designer will update the new design as explained below.

The various critical as well as other dimensions are entered in parametric rotor design input dialog box as shown in figure 7. On clicking the CAD button, all the inputs will be sent to the respective cells of the design table which is linked with the Rotor 3D model. Figure 8 shows the dynamic updating of the design table and so the model of the rotor. Figure 9 shows the design output ready for manufacturing.

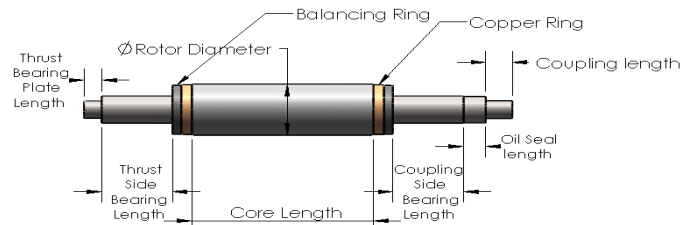

Figure 3 Nomenclature of a Rotor for parametric design

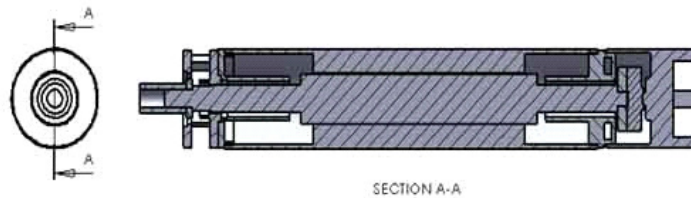

Figure 4 Rotor Arrangement in a typical submersible motor

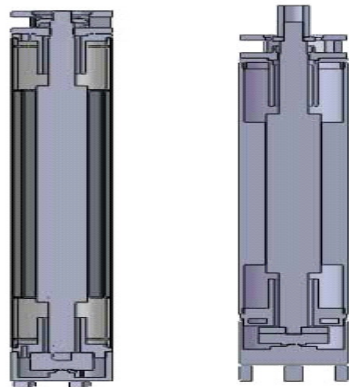

Figure 5 Sectional view to indicate Rotor position in a 100 mm and 150 mm Submersible

motor	
1. Enter Rotor Diameter in mm	72
2. Enter Core or Stack Length in mm	205
3. Enter Copper Ring Diameter in mm	71
4. Enter Copper Ring Thickness in mm	15
5. Enter Balancing Ring Diameter in mm	70
6. Enter Balancing Ring Thickness in mm	15
7. Enter Journal diameter in mm	37.95
8. Enter Thrust Bearing Side Bearing Length in mm	100
9. Enter Coupling Side Bearing Length in mm	120
10. Enter Shaft Diameter for Oil Seal in mm	36.8
11. Enter Length for Shaft Diameter (Oil Seal) in mm	25
12. Enter Shaft diameter for Coupling in mm	25
13. Enter length for shaft diameter (Coupling) in mm	40
14. Enter Thrust bearing plate shaft diameter in mm	25
15. Enter Thrust bearing plate length in mm	20
CAD	

Figure 7 Parametric rotor design input dialog box

	A	B	C	D	E	F	G	H	I	J	K	L	M	N	O	P	Q	R	S	T	U	V	W
1	Design Table for: parametricrotor																						
2		D1@Sketch1	D1@Extrude1	D1@Sketch3	D1@Extrude2	D1@Sketch4	D1@Extrude3	D1@Sketch6	D1@Extrude4	D1@Sketch7	D1@Extrude5	D1@Sketch8	D1@Extrude6	D1@Sketch9	D1@Extrude7	D1@Sketch10	D1@Extrude8	D1@Sketch11	D1@Extrude9	D1@Sketch12	D1@Extrude10	\$DESCRIPTION	
3	Default	72	205	70	12	70	12	69	10	69	10	37.95	80	24	20	38	80	37	25	25	30	Default	
4																							

Figure 6 Design table for the Rotor

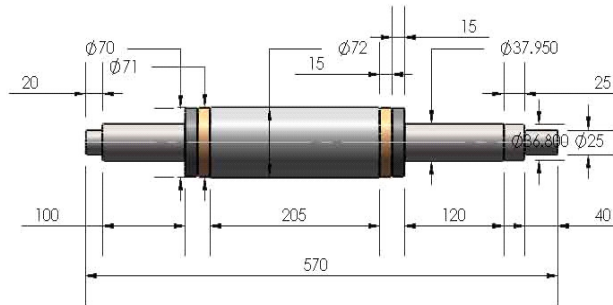

Figure 9 Design Output of 205 mm Core Length Rotor using Expert Designer

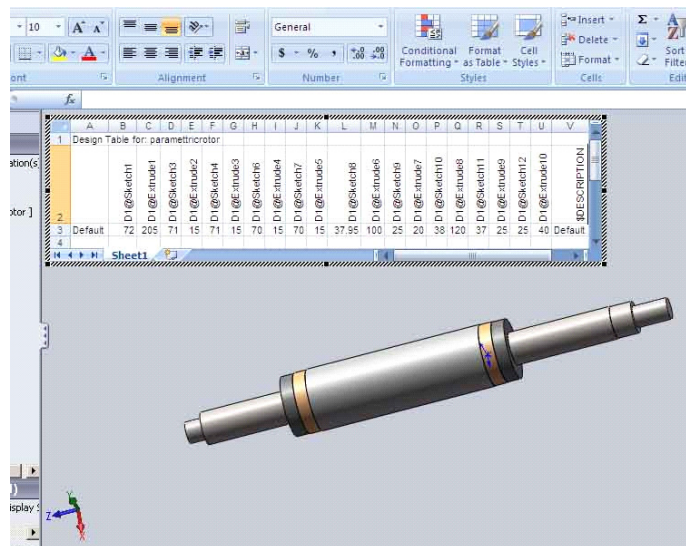

Figure 8 Design table dynamic updating and Rotor Model

4. CONCLUSION

It will provide the flexibility to design and manufacture motors & pumps very rapidly which is ultimately prerequisite of man customization.

Establishing proper design procedures and design critical components of the submersible motor as well as the pump

The parametric design of the critical component that its motor was established and software solution was developed for the same. The dimension of the rotor are

critical and interdependent. The flexibility thus obtained using the software will facilitate fast design of a submersible motor.

It has now been a statutory requirement for manufacturers and exporters like Vira pumps to get product certified by the BIT. Also manufacturers like Vira Pumps need to get Iso certification to get potential orders from customary especially when the scope is designed and developed.

REFERENCES:

- [1] Arsovski, Z., Arsovski, S., Mitrović, Z., Stefanović, M.,: Simulation of Quality Goals: A Missing Link Between Corporate Strategy And Business Process Management.. International Journal for Quality Research, Vol.3, No.4, pp. 317-326
- [2] K.R.Beattie, A.S.Sohal, Implementing ISO 9000: a study of its benefits among Australian organizations, Total Qual. Manage.10 (1) (1999) 95-106.
- [3] H.Liao, D.enke, H.Wiebe, An expert advisory system for the ISO 9001 quality system, Expert syst.Appl.27 (2) (2004) 313-322.
- [4] G.K. Sahu (2000), “ Pumps” ,New Age International pvt. Ltd. Publishers.
- [5] A.K. Sawhney (2003),”A course in electrical Machine Design”, Dhanapat Rai and Co.(P) Ltd.
- [6] IS 8034:2002 SUBMERSIBLE PUMPSETS SPECIFICATION
- [7] IS 9283:1995 MOTOR FOR SUBMERSIBLE PUMPSETS SPECIFICATION
- [8] Evangelos Petroustos,(2002),”Visual Basic.NET”, first edition,BPB publications.
- [9] Thearon Willis(2006), “ Beginning Visual Basic 2005 Databases” Wiley Dreamtech India(P) Ltd., New Delhi
- [10] Virajit Avinash Gandale, “ A new design approach for water cooled submersible motor and radial flow type pump with emphasis on both electrical and mechanical considerations.” PhD thesis, UNEM Costa Rica, /June 2010
- [11] Application of Design functionality rules in CAD/CAM. [Online]. Available : <http://conference.iproms.org/conference/download/4000/54>
- [12] CAD (Computer Aided Design). [Online]. Available: http://www.numa.org.br/conhecimentos/conhecimentos_ing/pag_conhec/cad.htm
- [13] Nicholas Bilaslis,” AUTOMATING THE PRODUCT DESIGN CYCLE FOR CUSTOM MADE PRODUCTS ” International Design Conferences-Design 2004,Dubrovnik, May 18-21, 2004

Acknowledgement:

First of all, I would like to express utmost gratitude to my Co-author **Prof.J.S.Bagi**, for his continued support, encouragement and guidance provided in articulating this paper.

Finally, I am very thankful to all those who extended their help directly or indirectly in preparation of this paper.

Received: 10.08.2011

Accepted: 06.01.2012

Open for discussion: 1 Year