

DESIGN, SIMULATION AND ANALYSIS OF A HYBRID-TYPE (PV/T) SOLAR AIR HEATER FOR HIGH PERFORMANCE

Pramod kumar N
Research Scholar,
Department of Mechanical Engineering, VVCE, Mysuru

B. Sadashive Gowda
Principal,
Vidyavardhaka College of Engineering, Mysuru, India

ABSTRACT

This paper deals with the numerical analysis of a Hybrid-Type (PV/T) Solar Air Heater and a study on the effect of various design parameters that enhance the performance of the system. The heat transfer improvement in general may be achieved by increasing the heat transfer coefficient or by increasing the surface area or by increasing both. The main objective of the present work is to determine the optimum air mass flow rate at which PV/T systems are to be operated and to develop an optimal design of a hybrid type (PV/T) solar air heater that shows better performance at various heat fluxes due to solar radiation. This study determines the set of design parameters which lead to the best annual yield of the system. In this study of a hybrid type (PV/T) solar air heater ICEM CFD (ANSYS) is used to obtain the optimum results, thereby increasing the efficiency of the system.

KEYWORDS - Computational fluid dynamics, Solar air heater, Photovoltaic-Thermal, Numerical simulation

INTRODUCTION

Solar energy is one of the clean and renewable forms of energy, which is available in abundance on earth. Though, it is dependent on location and changes with time can be easily convertible from one form of energy to another. It requires efficient collection and storage systems for economical utilization. Solar air heater among these systems is the simplest, cheap and most widely preferred device which is used to convert the solar energy into heat energy. The energy from these systems can be used in water-heating, pool heating, space-heating, solar desalination, etc. A solar air collector has an important place among solar thermal systems because it is widely used in many commercial applications such as the supply of hot air to school buildings, agricultural and industrial drying to dry products viz., cocoa, coffee beans, fruits, noodle, rubber or some marine products and paint spraying operations which are cost competitive and attractive applications [1].

A hybrid-type PV/T solar air heater is a kind of solar air heater which can produce electrical and thermal energy simultaneously, by achieving a higher energy conversion rate of the absorbed solar radiation. These systems consist of PV modules coupled to heat extraction devices in which air as a heat removing or

working fluid is made to flow through channels of the collector. Hot air from the outlet is utilized for drying agricultural products, space-heating, etc.

The electricity from the PV cells can be used in lighting home appliances. Therefore, a hybrid type PV/T collector can significantly make use of overall energy from sun and have a better environmental impact [5]. Only a small part of the absorbed solar radiation is converted to electricity, heat generated by the PV modules when solar radiation falls on it causes decrease in PV efficiency. But the thermal energy of the system increases with high intensity of solar radiation. A number of simulation and experimental studies have been carried out on the hybrid-type (PV/T) solar air heaters in order to enhance the overall performance of the system. But still it is a difficult task for the researchers to encounter the problems associated with the PV/T systems. From the literature study, it is evident that no work on hybrid-type (PV/T) solar air heater using ICEM CFD software is done.

The objective of the present study is to perform a CFD simulation of a hybrid type (PV/T) solar air heater using ICEM CFD software and to analyze the performance of the system at various operating condition. A 3D model of a hybrid-type (PV/T) solar air collector involving air inlet-outlet, absorber plate attached with longitudinal fins at bottom side and pasted with solar cells on the top surface, a bottom plate, a glass cover plate, back and side insulation is modeled using ICEM CFD, meshed and specified with the boundary conditions to carry out simulation. The results thus obtained, will be used to suggest an optimum design of solar air heater that yields better performance.

MATHEMATICAL FORMULATION

THE PHYSICAL MODEL AND COORDINATE SYSTEM

In view of the geometry, the Cartesian co-ordinate system is chosen to describe the geometry, where X, Y and Z axis are taken in the length, height and breadth of the solar air heater respectively. The distance between the upper channel and the lower channel where air enters and leaves the system is 0.05 m each. An absorber plate made of aluminum of dimensions $1 \times 2 \text{ m}^2$ and 0.002 m thick. The bottom and the other three sides of the collector are well insulated with polystyrene of 0.05 m thickness. The total area of solar cells is 1.12 m^2 . The specifications of PV cells are shown in Table 1 and schematic diagram of hybrid-type (PV/T) solar air heater is shown in Fig.1.

Table 1 Specifications of PV cells used in hybrid type (PV/T) solar air heater

| Parameter | Value |
|------------------------------------|--------|
| Nominal peak power (W_p) | 80 W |
| Maximum power voltage (V_m) | 17.6 V |
| Maximum power current (I_m) | 4.7 A |
| Short circuit current (I_{sc}) | 5.2 A |
| Module efficiency (η_m) | 10% |
| Solar cell efficiency (η_c) | 13% |

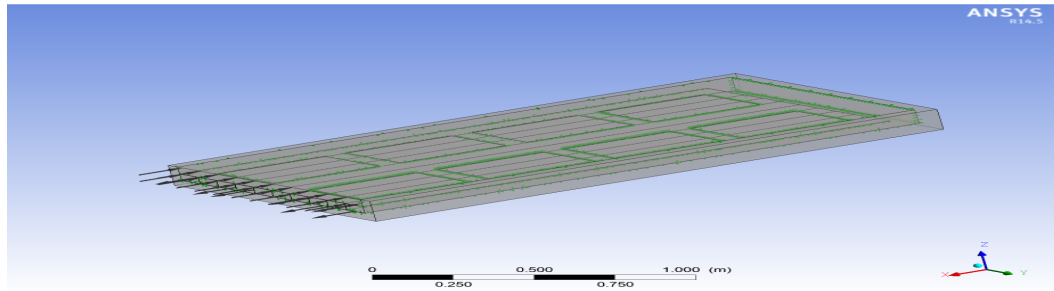

Fig.1 Schematic diagram of a hybrid-type (PV/T) solar air heater created using ICEM CFD

GOVERNING EQUATIONS

The basic equations governing the compressible in-viscous fluid flow, is the Reynolds Averaged Navier-Stokes Equation.

$$\frac{\partial U}{\partial t} + \frac{\partial F(U)}{\partial x} + \frac{\partial G(U)}{\partial y} = 0$$

And the flux vectors $F(U)$, $G(U)$ and $H(U)$ are defined as

$$F(U) = y \begin{bmatrix} \rho u \\ \rho u^2 + p - \tau_{xx} \\ \rho uv - \tau_{xy} \\ u(p + e - \tau_{xx}) - \tau_{xx}v + q_x \end{bmatrix}$$

$$G(U) = y \begin{bmatrix} \rho uv - \tau_{xy} \\ \rho v^2 + p - \tau_{yy} \\ v(p + e - \tau_{yy}) - \tau_{xy}u + q_y \end{bmatrix}$$

$$H(U) = y \begin{bmatrix} 0 \\ 0 \\ -p + \tau_{\theta\theta} \\ 0 \end{bmatrix}$$

The viscosity in the stress term is replaced by μ_T in a turbulence flow of viscous fluid. Therefore this model is a two layer eddy viscosity model and is given by

$$\mu_T = \begin{cases} \mu_{Ti} & y \leq y_x \\ \mu_{T0} & y > y_x \end{cases}$$

Where y is the normal distance from the wall and y_x is the smallest value of y at which the values of inner and outer formulas are equal.

MESHING AND PRE-PROCESSING

- ✓ The model is created using ICEM CFD software.
- ✓ Parts are named as inlet, outlet, glass cover, outer case, aluminium plate, bottom plate.
- ✓ Global Mesh parameters are defined that gives us information regarding type of mesh. The global mesh element size and part parameters are setup, finally mesh is computed which gives us the mesh information regarding total number of elements.
- ✓ An unstructured tetra mesh is generated in order to perform computations with the Octree approach.
- ✓ The model is then meshed and processed further with CFD Pre-Solver where the material properties, domain and boundary conditions are specified.
- ✓ The solver solves all the solution variables for the problem specification generated in CFX – Pre.
- ✓ Finally, the CFX – Post provides post-processing graphics tools to analyze and presents the CFX simulated results.

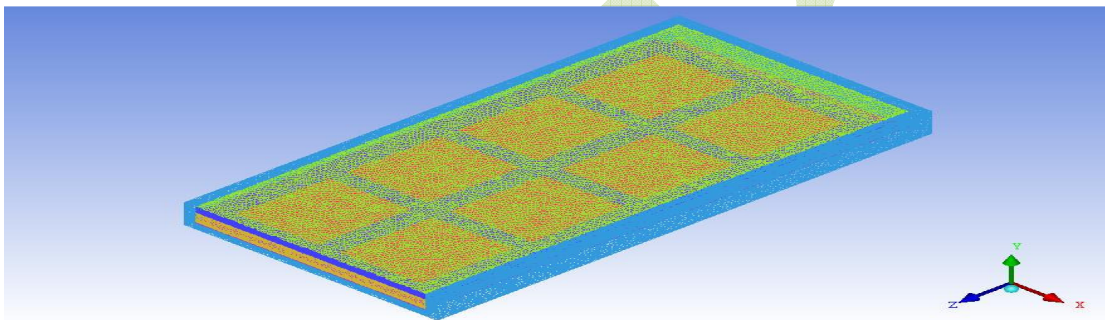

Fig.2 Meshed model of a hybrid solar air heater

BOUNDARY CONDITIONS

The important boundary conditions specified for the computation of a PV/T solar air heater are as follows:

1. Inlet: Air at a mass flow rate of 0.007 kg/s and at a constant temperature of $T_i = 305$ K is passed through the upper channel.
2. Outlet: Relative pressure is set to zero, which facilitates the air flow within the system.
3. Glass: Solar heat flux is specified at varying range from 800 W/m^2 to 650 W/m^2
4. Wall: The no slip condition and smooth surface conditions are used.

In the analyses, four domains were considered for the computation viz., air as a fluid domain, silicon (solar cell), polystyrene and aluminium as solid domains. There were no moving parts (all parts were stationary) with reference pressure at 1 atm. All other parts within the polystyrene and glass cover are assumed to have conservative heat flux.

VALIDATION

The problem is solved using ANSYS CFX and the code is validated with the results of a research paper [5] for accuracy and correctness. For modeling, the dimensions of the same were maintained as described in the research paper and validation is carried out for three different heat fluxes at 0.007kg/s air mass flow rate and at a constant inlet temperature of 305 K. It is found that the results thus obtained from simulation well agreed with the results of the published work, as shown in Fig. 3 to 6 below.

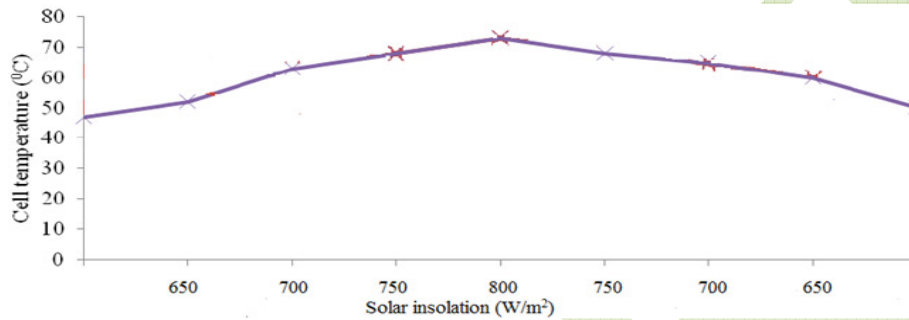

Fig.3 Plot of cell temperature v/s solar radiation of previous work

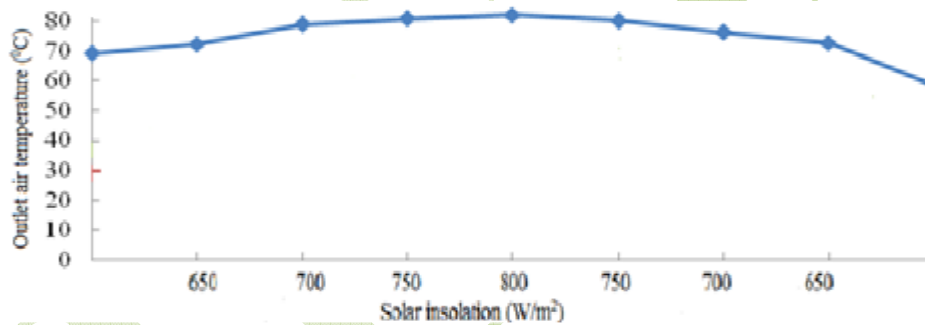

Fig.4 Plot of outlet air temperature v/s solar insolation of previous model

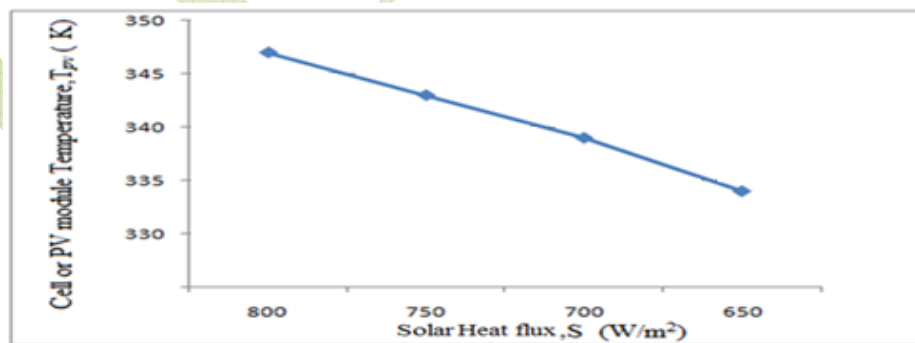

Fig.5 Variation of cell temperature v/s solar heat flux in present work

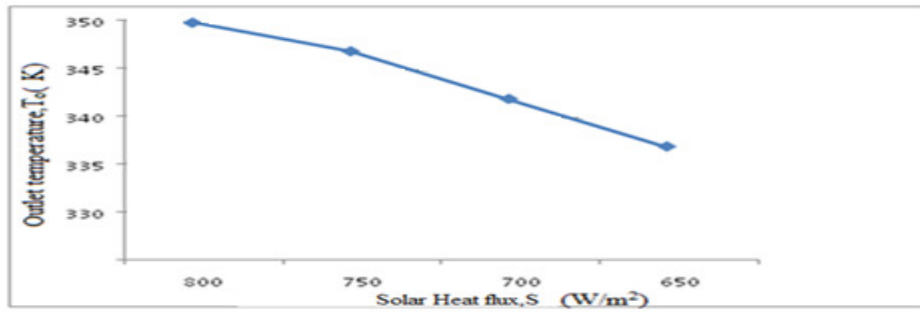

Fig.6 Variation of outlet temperature v/s solar heat flux in present work

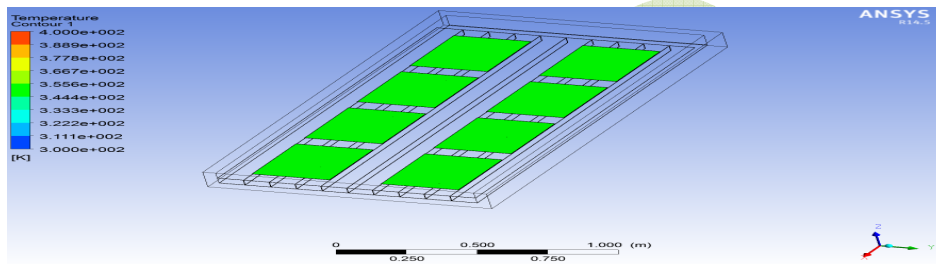

Fig.7 Temperature contour of solar cell at solar heat flux of 800 W/m²

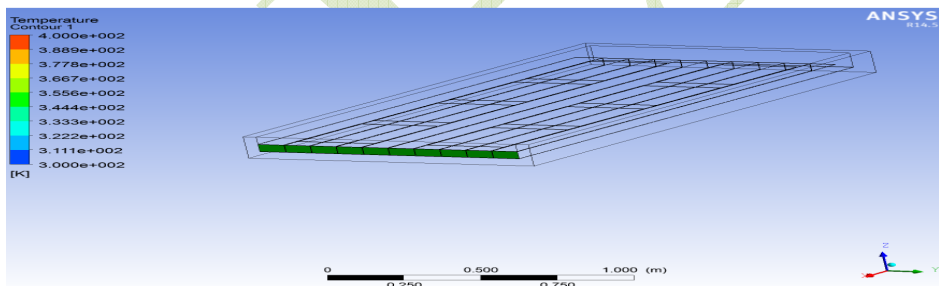

Fig.8 Temperature contour of air outlet at solar heat flux of 800 W/m²

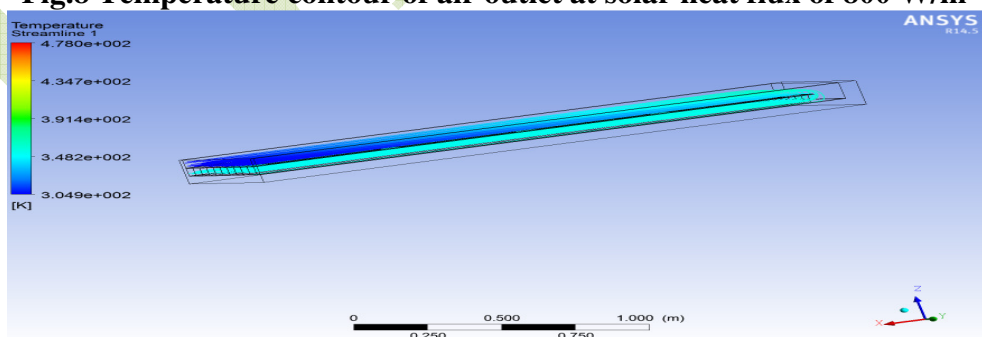

Fig.9 Temperature profile of air from inlet to outlet at solar heat flux of 800 W/m²

Performance analysis

The performance of this combined hybrid type PV/T system is studied by applying the first and second laws of thermodynamics. The energy balance is based on the first law of thermodynamics.

$$\eta_{th} = \frac{\dot{m}C_p(T_o - T_i)}{SA_c} * 100 \tag{1}$$

$$\eta_{el} = \eta_{ref} [1 - \beta(T_{pv} - T_{ref})] \tag{2}$$

RESULTS AND DISCUSSION

In the present study 3-D models of three different geometries of hybrid-type solar air heater are created by using ICEM CFD and were simulated with different air mass flow rates and at different solar heat fluxes to analyze the performance of the system. The design parameters that were altered are viz. the surface area, the distance of separation between the upper and lower channel of air flow, longitudinal fins and artificial roughness on absorber-bottom plate. Figures 12 to 15 show the results generated by ANSYS CFX, where we have temperature contours shown by different colors, which describe the flow and temperature field characteristics within the system for different design configurations.

Design 1: Absorber-Bottom plate with wedge shape ribs

To enhance the performance of the system, applying artificial roughness on the heat transfer surface is a well known application. Relative roughness height of 25 mm and relative roughness pitch of 200 mm (9 numbers per 2 m width below the absorber plate and 10 numbers per 2.1 m above the bottom plate) to maintain the angle of attack of 10^0 as shown in the Fig.10 and Fig.11. Upper channel between the glass cover and absorber plate is separated by 43 mm and the lower channel (outlet) between the absorber plate and bottom plate is separated with a height of 85 mm. Air at a mass flow rate of 0.012 kg/s. The solar heat flux is specified on the glass surface ranging from 800 – 650 W/m².

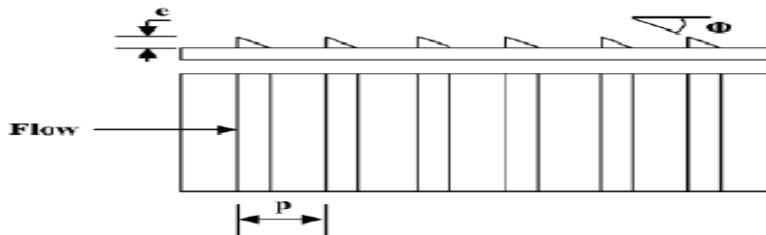

Fig.10 Velocity profile of air from inlet to outlet

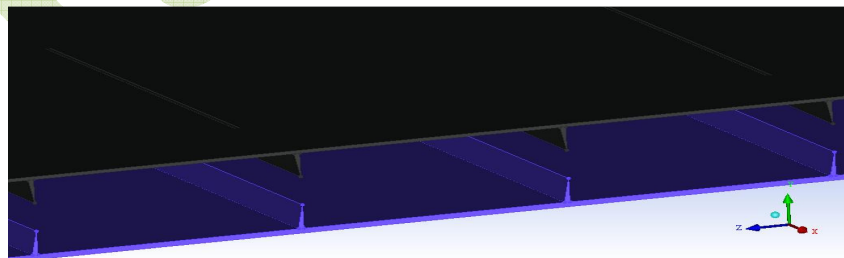

Fig.11 Absorber-Bottom plate with wedge shape ribs

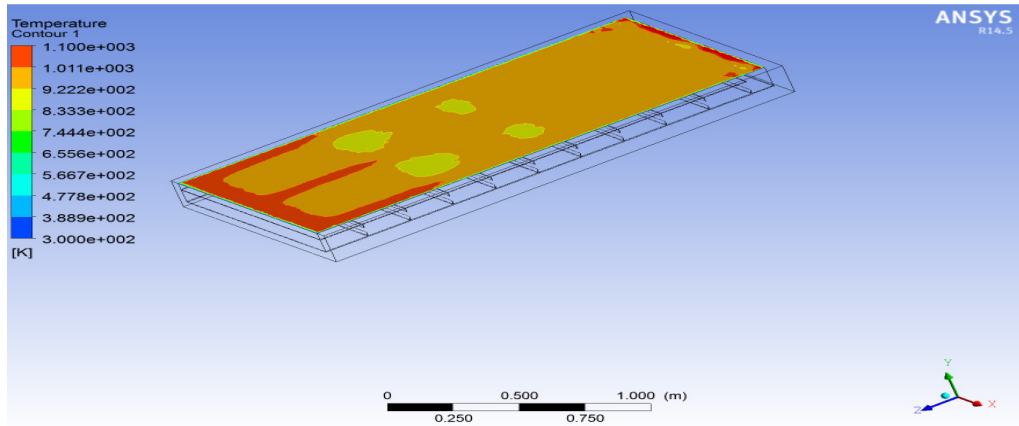

Fig.12 Temperature contour of glass at solar heat flux of 800 W/m^2

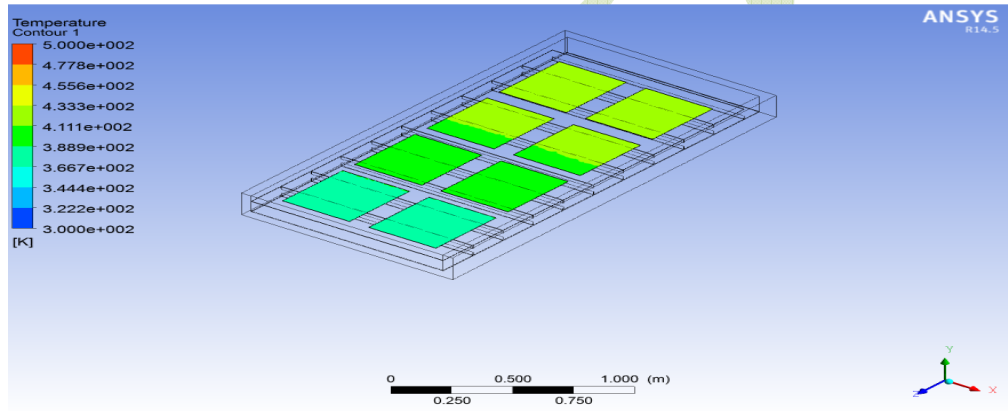

Fig.13 Temperature contour of solar cell at solar heat flux of 800 W/m^2

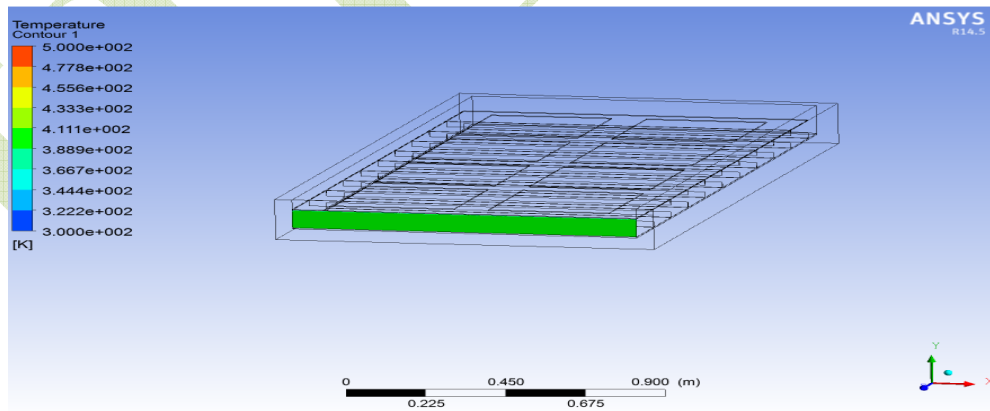

Fig.14 Temperature contour of air outlet at solar heat flux of 800 W/m^2

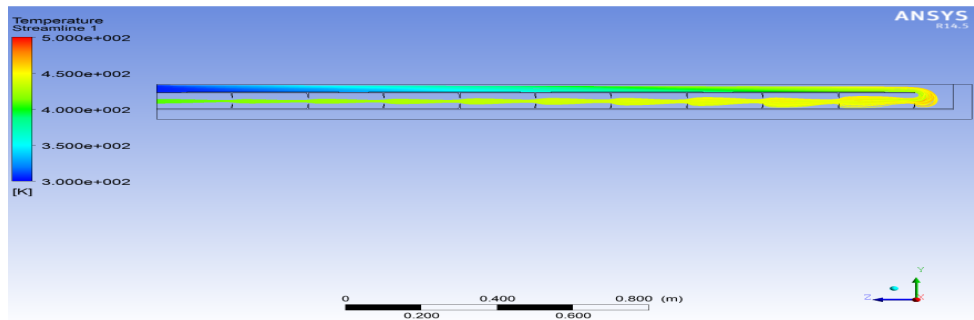

Fig.15 Temperature profile of air from inlet to outlet at solar heat flux of 800 W/m^2

At 800 W/m^2 heat flux, the outlet temperature of air is 408 K and the corresponding thermal efficiency is about 74%. The outlet temperature of air is high, enhances the thermal efficiency of the system and it is observed that the temperature on the cell surface was too high, leads to drop in electrical efficiency of the system.

Design 2: Hybrid (PV/T) solar air heater with baffle and fins

In this design, the baffle of radius 35.5 mm at the extreme end is provided where the air turns and travels through the lower channel as a shown in the Fig.16. Longitudinal fins of height 20 mm and thickness 2 mm (10 numbers per length) at the bottom side of the absorber plate as well as on the top surface of the bottom plate is provided for effective heat transfer of air. The baffle is provided at the extreme end to avoid the pressure losses, which has an impact on air that travels both in the upper channel (forward direction) and the lower channel (reverse direction). The collector surface area is increased and the fins are arranged alternatively in such a way that there is no intersection or overlapping between them along the length of the absorber and bottom plate. The inlet air temperature is assumed as 305 K and is operated at two air mass flow rates of 0.012 kg/s and 0.019 kg/s. The inlet of air is between the glass plate and the absorber plate i.e., the upper channel of height 30 mm and outlet with a distance of separation of 45 mm between the absorber and the bottom plate.

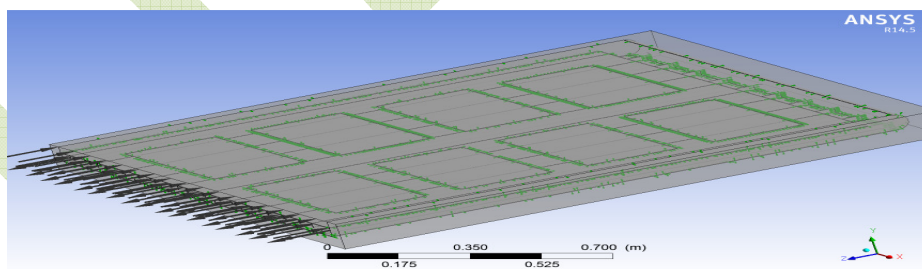

Fig.16 A hybrid (PV/T) solar air heater with baffle and fins

Figures 17 to 19 below represents the temperature contours of cell temperature, outlet temperature and temperature profile of air for mass flow rate of 0.019kg/s at solar heat flux of 650 W/m^2 .

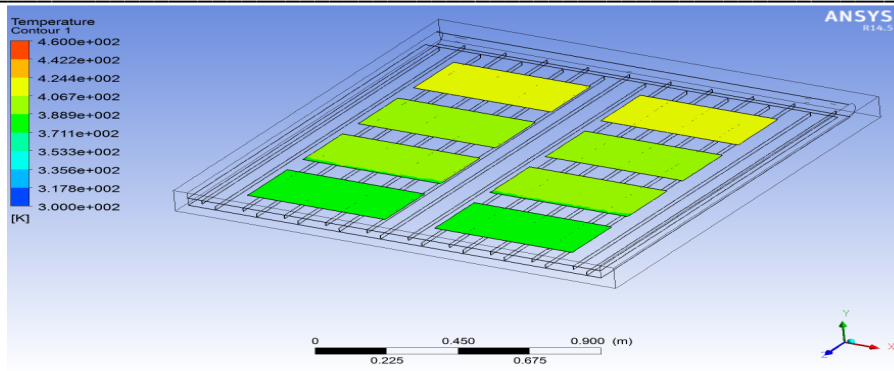

Fig.17 Temperature contour of solar cell at solar heat flux of 650 W/m^2

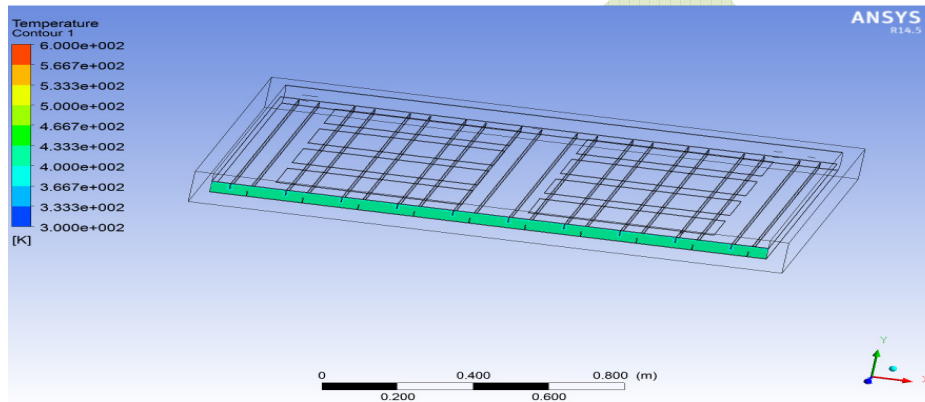

Fig.18 Temperature contour of air outlet at solar heat flux of 650 W/m^2

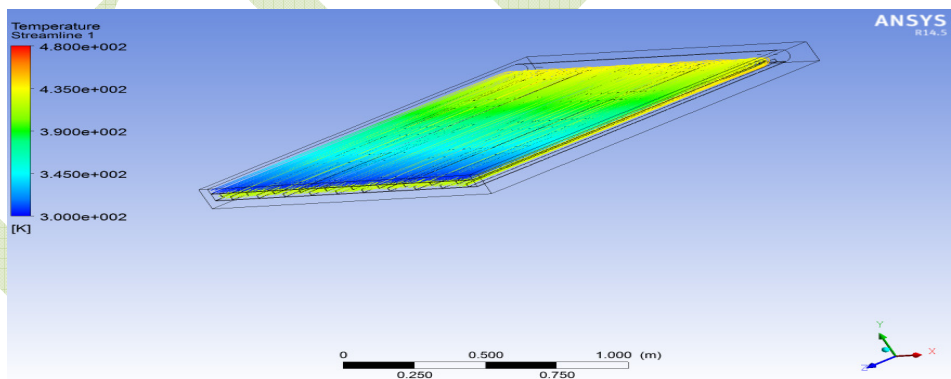

Fig.19 Temperature profile of air from inlet to outlet at solar heat flux of 650 W/m^2

The cell temperature is in the acceptable range at low solar heat flux value of 650 W/m^2 . The corresponding electrical efficiency is 8.4%, if the cell temperature at higher solar heat flux decreases below 360 K then there will be increase in electrical efficiency.

Design 3: Hybrid type (PV/T) solar air heater with inlet at one end and outlet at the other end

A new design of hybrid type (PV/T) solar air heater is as shown in Fig.20, where the air enters from one side of the system and then exits from the outlet at the other end. Air inlet is between the glass plate and the absorber plate of height 35 mm where the cold air enters the system at one end. The air outlet is at the other end with a height of 40 mm between absorber and bottom plate from where the hot air exits the system.

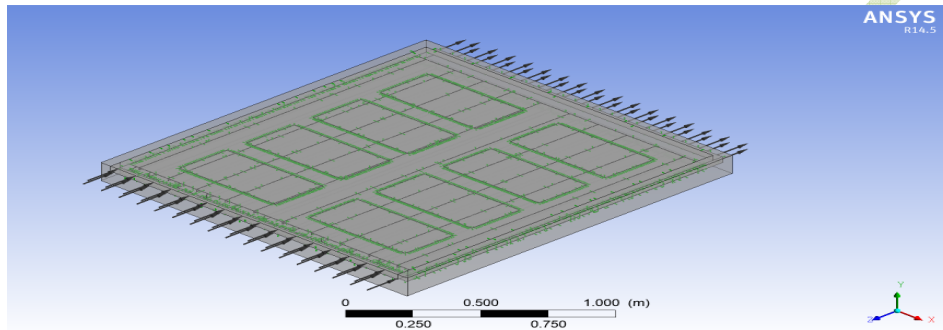

Fig.20 Hybrid type (PV/T) solar air heater with inlet at one end and outlet at the other

Solar heat flux defined on the glass surface is $800\text{-}650\text{ W/m}^2$. The initial temperature of air at inlet is 305 K , and at two different mass flow rates of 0.012 kg/s and 0.019 kg/s . Figures below represents the temperature contours of glass, air inlet, cell temperature, outlet temperature and temperature profile of air for mass flow rate of 0.019 kg/s from inlet to outlet at solar heat flux of 800 W/m^2 .

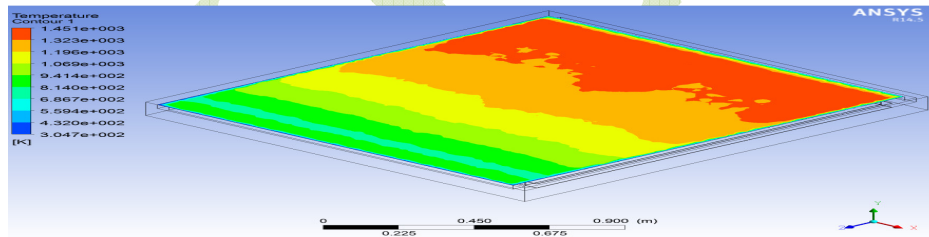

Fig.21 Temperature contour of glass at heat flux of 800 W/m^2

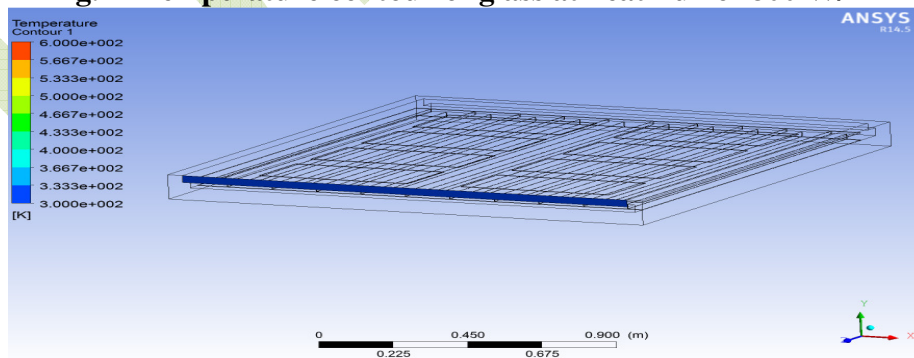

Fig.22 Temperature contour of air inlet at 305 K

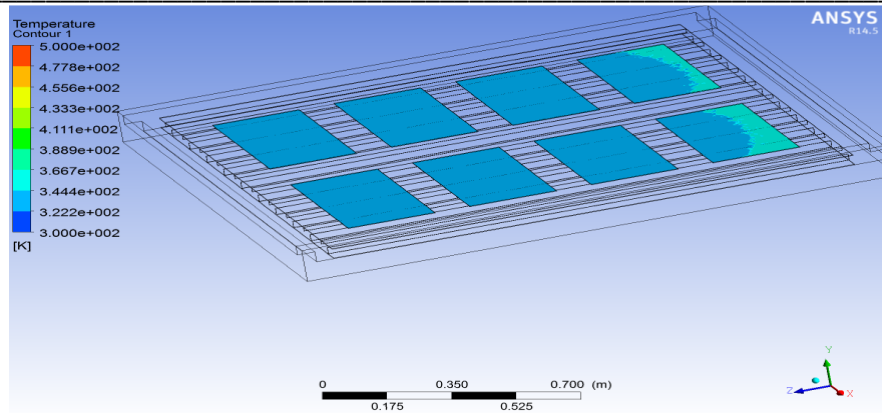

Fig.23 Temperature contour of solar cell at solar heat flux of 800 W/m^2

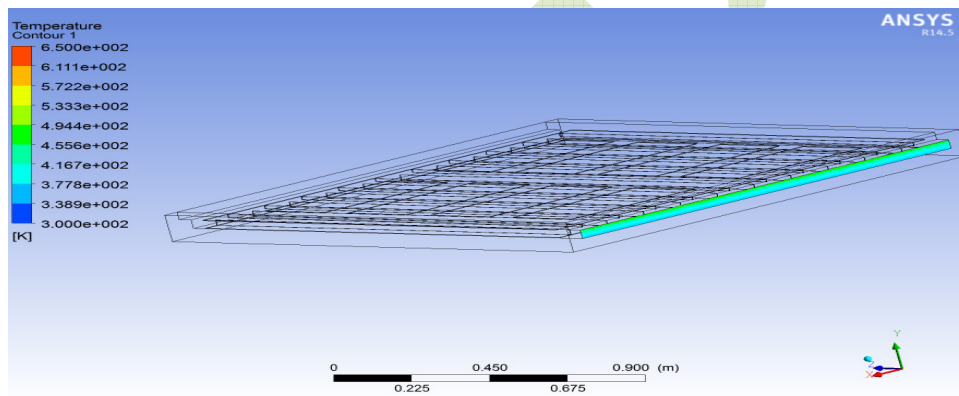

Fig.24 Temperature contour of air outlet at solar heat flux of 800 W/m^2

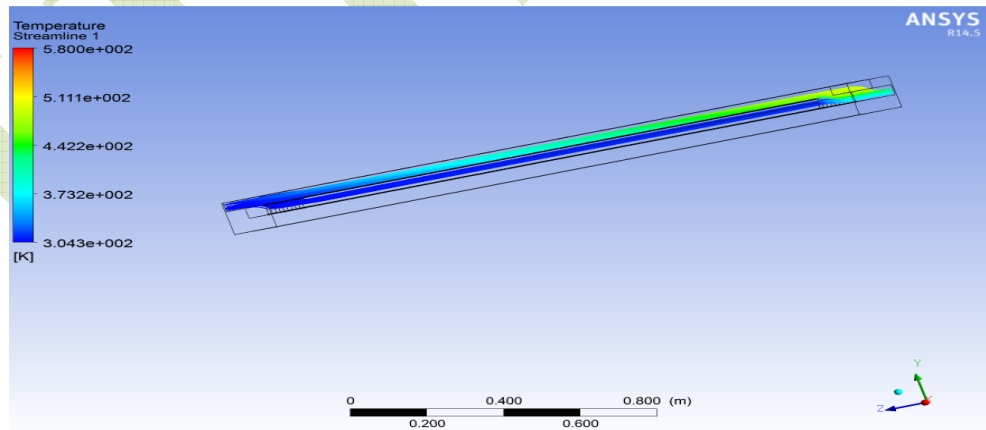

Fig.25 Temperature profile of air from inlet to outlet at solar heat flux of 800 W/m^2

In this case, the effective heat transfer is achieved as the air passes in only one direction through the upper and lower channel. The same gets heated up and cools the surface temperature of cell simultaneously. The system is operated at air mass flow rate of 0.019 kg/s and solar heat flux range from 800-650 W/m² showed better electrical behavior. The electrical efficiency recorded at this condition is around 10.6%. Hence this design of hybrid-type (PV/T) solar air heater is suggested for achieving high performance.

CONCLUSIONS

From the analysis carried out, the following conclusions are made

- **Design 1 - Absorber-Bottom plate with wedge shape ribs:** In the analysis of this design, the electrical efficiency drops, as the surface temperature of cell measured is exceeding the cell operating temperature at air mass flow rate of 0.012 kg/s.
- **Design 2 - Hybrid (PV/T) solar air heater with baffle and fins:** The thermal efficiency was good, but still the electrical efficiency required little enhancement in this case.
- **Design 3 - Hybrid type (PV/T) solar air heater with inlet at one end and outlet at the other end:** In this design, the air mass flow rate of 0.019 kg/s was optimum among the two mass flow rates at which the system was operated. The electrical and thermal efficiencies achieved are 10% and 115% respectively.

REFERENCES

1. M. Y. OTHMAN, B. YATIM, K. SOPIAN, M. N. A. BAKAR, (2006) “*Design of a Double-Pass Photovoltaic-Thermal Air Collector with a Compound Parabolic Concentrator and Fins*”, *Journal of Energy Engineering*, Vol. 132, No. 3, December 1.
2. CHANTANA PUNLEK, RATTANACHAI PAIRINTRA, SIRINUCH CHINDARAKSA, SOMCHAI MANEEWAN, (2009) “*Simulation Design and Evaluation of Hybrid PV/T Assisted Desiccant Integrated HA-IR Drying System (HPIRD)*”, *food and bio-products processing* pp 77–86.
3. BHASKAR JOSHI, RANJIT SINGH, BRIJ BHUSHAN, (2011) “*Effect of Long way Length of Roughness Element on Performance of Artificially Roughened Solar Air Heater Duct*”, *International Journal of Advanced Engineering Technology (IJAET)* E-ISSN 0976-3945, Vol.III/ Issue III/July-September, pp 130-136.
4. M. SRINIVAS, S. JAYARAJ, (2013) “*Investigations on the performance of a double pass, hybrid - type (PV/T) solar air heater*”, *International Journal of energy and environment*, Volume 4, Issue 4, pp.687-698.
5. ARUN KUMAR YADAV; AMITESH PAUL; G. R. SELOKAR, (2013) “*CFD Based Performance Analysis of Artificially Roughened Solar Air Heater*”, *International Journal of Emerging Technologies in Computational and Applied Sciences*, 5(2), June-August, pp. 129-133.