



# Journal of Materials and Engineering Structures

## Research Paper

### Creep investigation of GFRP RC Beams - Part B: a theoretical framework

Abdelmonem Masmoudi\*<sup>a</sup>, Mongi Ben Oueddou<sup>b</sup>, Mohamed Beldi<sup>b</sup>, André Weber<sup>c</sup>

<sup>a</sup> Laboratory of Mechanics, Modeling and Manufacturing, National School of Engineers of Sfax, Tunisia

<sup>b</sup> Civil Engineering Laboratory, National Engineering School of Tunis, B.P 1173, 3038, Tunisia

<sup>c</sup> Research and Development Center, FRP Combar® Schöck, Baden-Baden, Germany

#### ARTICLE INFO

##### Article history :

Received : 7 July 2014

Revised : 30 September 2014

Accepted : 11 October 2014

##### Keywords:

GFRP Bars

superposition principle

equivalent time

return creep reloading

#### ABSTRACT

This paper presents an analytical study about the viscoelastic time-dependent (creep) behavior of pultruded GFRP elements made of polyester and E-glass fibres. Experimental results reported in Part A are firstly used for material characterization by means of empirical and phenomenological formulations.

The superposition principles by adopting the law of creep following the Eurocode 2 recommendations are also investigated. Analytical study was also conducted including creep under constant stress; successions of increasing stress superposition principle equivalent time and the return creep reloading. The results of this study revealed that Beams reinforced with GFRP are less marked with creep phenomenon. This investigation should guide the civil engineer/designer for a better understanding creep phenomenon in GFRP reinforced concrete members.

#### List of symbols

- $\mathcal{E}_{ic1}$  : Conventional instantaneous deformation  
 $E_{i28}$  : Instantaneous modulus of concrete at 28 days  
 $K_{\beta}(t_1)$  : Creep coefficient  
 $\rho_s$  : Percentage of adherent reinforcement  
 $K_e$  : The lower limit of creep coefficient.

\* Corresponding author. Tel.: +216 98 457 655.  
 E-mail address: abdelmonem.masmoudi@enis.rnu.tn

- $\rho_h$  : Ambient humidity expressed as a percentage relative humidity  
 $r_m$  : The mean radius of a piece expressed in centimeters  
 $f(t - t_1)$  : The evolution law of creep given by the expression  
 $(t - t_1)$  : Time of loading in days  
 BAEL : *in French* : Béton Armé aux Etats Limites (Limit States Design of reinforced Concrete)  
 BPEL : *in French* : Béton Précontraint aux Etats Limites (Limit States Design of Prestressed concrete)  
 $s_{rz}$  : Shear area ratio  
 M : Bending moment  
 V : Shear force

## 1 Introduction

When considering a design using GFRP Rebar, the differences in physical properties and performance characteristics must be taken into account. Of chief importance to the designer is the fact that all FRP structures are linear elastic up to failure and exhibit no ductility or yielding. Usually, a service life of at least 50 years is required for most civil engineering structures. These particular materials exhibit a viscoelastic mechanical behaviour, which must be taken into account in the analysis and design of any civil engineering structure [1]. The creep parameters and deformation estimated by using the Findley's model derivations indicate a consistent prediction of time-dependent deformation and viscoelastic properties of the two types of elements analysed – laminates and beam. A straightforward formulation to predict the time-dependent elastic modulus is applied, showing that the flexural stiffness should be reduced by 25% of its initial value after 1-year and as much as 50% after 50-years. Similarly, the power law coupled to Euler's classical beam theory suggests a reasonable adaptability to the creep phenomenon in the linear regime and proved to provide accurate predictions for deflections under flexural loading up to 40% of the ultimate strength. After 50 years, under normal service load level (1/3 of the failure load), the total creep deflection will attain almost twice the initial deflection. If taking into account the shear deformation (Timoshenko's postulated) of the full-size element with "effective" stiffness properties such estimate is reduced nearly 25% [2].

When subjected to a constant stress step, viscoelastic materials experience a time-dependent increase in strain. This phenomenon is known as viscoelastic creep [3]. Below a critical value of applied stress, a material may exhibit linear viscoelasticity. Above this critical stress, the creep rate grows disproportionately faster. The second way of graphically presenting viscoelastic creep in a material is by plotting the creep modulus (constant applied stress divided by total strain at a particular time) as a function of time [4].

Below its critical stress, the viscoelastic creep modulus is independent of applied stress. A family of curves describing strain versus time response to various applied stress may be represented by a single viscoelastic creep modulus versus time curve if the applied stresses are below the material's critical stress value [5].

## 2 Analytical investigation

### 2.1 Creep under constant stress

According to the BAEL French code [6], the modulus of instantaneous deformation is three times larger than the modulus of deformation delayed  $E_{vj}$  ( $E_{ij} = 3E_{vj}$ ). In the relationship  $\sigma = E \cdot \varepsilon$  and under equal charges, the value of the module E gets bigger as the value of the deformation grows larger. BPEL code give formulas for evaluating appropriately, the expected value of the creep strain after a t time loading. The creep of concrete at t time, at the age  $j = t_1$  days subject to a constant stress is given by the following equation:

$$\varepsilon_{fl}(t) = \varepsilon_{ico} \times K_{fl}(t_1) \times f(t - t_1) \quad (1)$$

$\varepsilon_{ic1}$  : Conventional instantaneous deformation under the effect of  $\sigma_{b1}$  ( $\varepsilon_{ic1} = \sigma_1 / E_{i28}$ ) with  $E_{i28}$  the instantaneous modulus of concrete aged at 28 days.

$K_{fl}(t_1)$  : Coefficient of creep, which depends on the age of concrete at loading. It is determined from the following expression:  $K_{fl}(t_1) = K_s \cdot (K_e + K_c \cdot K(t_1))$

$K_s = \frac{1}{1 + 20\rho_s}$  with  $\rho_s$  the percentage of adherent reinforcement  $\rho_s = \frac{A_s}{B}$ , ratio of the longitudinal passive reinforcement to the cross section of the piece

$K_e$  : represents the lower limit of the coefficient of creep of plain concrete when it is loaded very old and is taken at 0,4 ;

$K_c$  : depends on ambient conditions and the mean radius of the piece:

$$K_c = \frac{120 - \rho_h}{30} + \frac{2}{3} \left( \frac{100 - \rho_h}{20 + r_m} \right) \tag{2}$$

with

$\rho_h$  : Ambient humidity expressed as a percentage relative humidity,

$r_m$  : The mean radius of the piece expressed in centimeters

$K(t_1)$  : depends on the hardening of concrete at the age of loading, it is given by:  $K(t_1) = \frac{100}{100 + t_1}$  with  $t_1$  : age of concrete in days counted from the date of manufacture  $f(t - t_1)$  : is the evolution law of creep given by the expression

$$f(t - t_1) = \frac{\sqrt{t - t_1}}{\sqrt{t - t_1} + 5\sqrt{r_m}} : (t - t_1) : \text{duration of loading in days; } r_m \text{ in cm.}$$

**2.1.1 Physical meaning of the words:  $\mathcal{E}_{ic1}$ ,  $K_{fl}(t_1)$  and  $f(t - t_1)$**

Before studying the creep and prediction of creep deformation delayed it is important to give the physical meaning of the following words:  $\mathcal{E}_{ic1}$ ,  $K_{fl}(t_1)$  and  $f(t - t_1)$

The term  $\mathcal{E}_{ic1}$  was too often seen as an instantaneous deformation; in fact this term includes the following two points:

- Creep is proportional to the applied stress (linear creep)
- Creep is inversely proportional to the modulus of concrete (the value of creep is smaller if the concrete is stiffer)
- The coefficient  $K_{fl}(t_1)$  included the aspects of the phenomenon of creep
- The term  $\rho_s$  takes into account the influence of bars that oppose the flow of concrete. The terms  $\rho_h$  and  $r_m$  are to express the influence of drying on creep, indeed a very important part of creep is related to the drying of concrete. Finally, the age of concrete is a link to aging (maturing) of the material: the older the concrete, the less the value of creep found.

The function  $f(t - t_1)$  reflects the kinetics of the phenomenon of creep. It depends on the mean radius (here we find the scale effect linked to creep) and the duration of the load.

**2.2 Succession of increasing stress**

In the case of a succession of growth constraints, the French law provides two ways to calculate the creep deformation:

- The principle of superposition
- The method of equivalent time

We propose in this section to examine these two ways from a simple case of loading in two levels shown in the figure below (Figure 1)

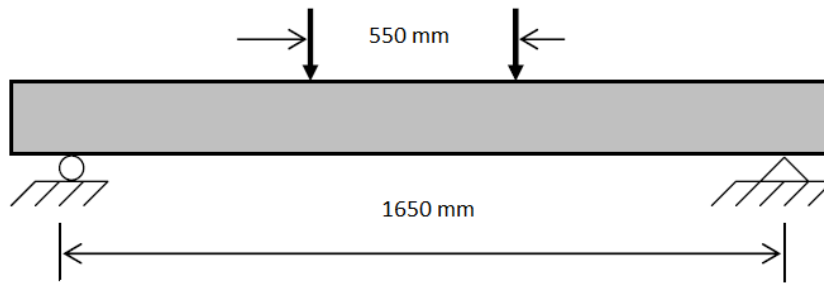

*Fig. 1 – Schematic diagram of testing arrangement*

**2.2.1 Principle of superposition**

In the case of loading as showed in Figure 2, the strain response is obtained by superposing the effects of each stress range.

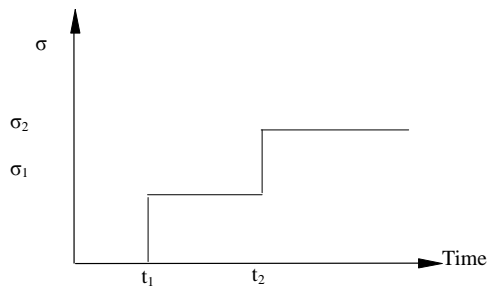
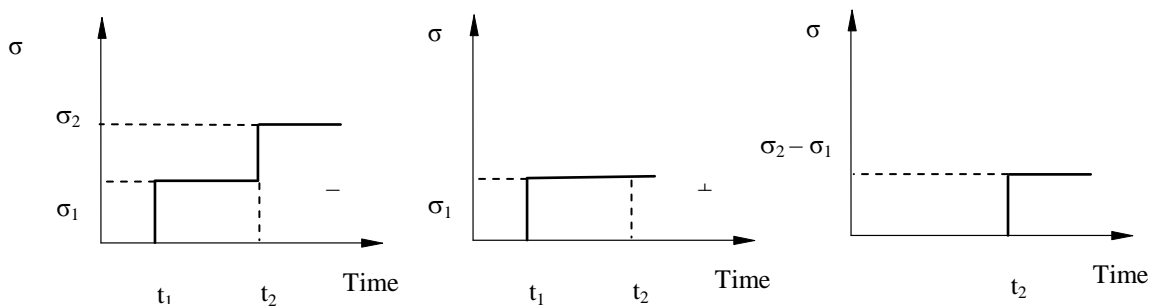

*Fig. 2 – Two stage simple loading*

**2.2.1.1 Expression of the creep deformation**

The expression of creep deformation will be developed in the particular case of two levels and in the general case of n constraints marked shortening  $\Delta\sigma_i$  with i ranging from 1 to n.

The principle of superposition implies that the deformation response is obtained by superposing the effects of each stress range. This can result graphically as shown in Figure 3.



*Fig. 3 – Stress response by effects superposition*

In terms of delayed deformation, the response deformation by superposition effects is shown in Fig 4.

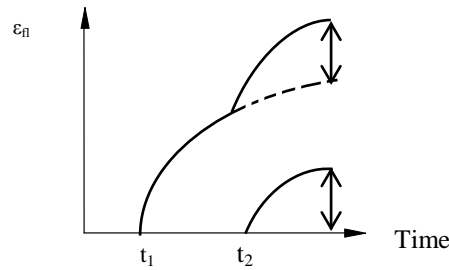

**Fig. 4 – Response deformation by superposition effects**

Therefore

$$\varepsilon_{fl(t)} = \frac{\sigma_1}{E} \cdot K_{f_l}(t_1) \cdot f(t-t_1) + \frac{\sigma_2 - \sigma_1}{E} \cdot K_{f_l}(t_2) \cdot f(t-t_2) \tag{3}$$

Generalizing to the case of n increased stress, creep deformation can be written

$$\varepsilon_{fl(t)} = \sum_{j=1}^n \Delta\varepsilon_j \cdot K_{f_l}(t_j) \cdot f(t-t_j)$$

2.2.1.2 Calculation of the delayed deformation of the concrete after 300 days 1000 and 3000 days

Numerical application for n=2 using data in Table 1

**Table 1: Data for calculating the effect superposition**

t <sub>1</sub> (days)	t <sub>2</sub> (days)	σ <sub>1</sub> (MPa)	σ <sub>2</sub> (MPa)	Ei 28 (Mpa)	ρ <sub>h</sub>	r <sub>m</sub> (cm)	ρ <sub>s</sub>
8	28	8	16	32000	70	36	0.02

$$K_{fl} = K_s \cdot (0,4 + K_c \cdot K(t_j))$$

$$K_s = \frac{1}{1 + 20\rho_s} = 0,7143$$

$$K_c = \frac{120 - \rho_h}{30} + \frac{2}{3} \cdot \left( \frac{100 - \rho_h}{20 + r_m} \right) = 2,024$$

$$K(t_0) = \frac{100}{100 + t_j}$$

$$K_{fl}(8) = 1,624 \quad K_{fl}(28) = 1,415$$

$$\varepsilon_{fl(t)} = \frac{\sigma_o}{E} \cdot K_{f_l}(t_1) \cdot \frac{\sqrt{t-t_0}}{\sqrt{t-t_1} + 5\sqrt{r_m}} + \frac{\sigma_2 - \sigma_1}{E} \cdot K_{f_l}(t_1) \cdot \frac{\sqrt{t-t_1}}{\sqrt{t-t_1} + 5\sqrt{r_m}}$$

$$t= 300 \text{ j} \quad \varepsilon_{fl(300)} = 272,8 \mu\text{m} / \text{m}$$

$$t= 1000 \text{ j} \quad \varepsilon_{fl(1000)} = 387,4 \mu\text{m} / \text{m}$$

$$t= 3000 \text{ j} \quad \varepsilon_{fl(3000)} = 490,4 \mu\text{m} / \text{m}$$

2.2.2 Equivalent time

This method can be reduced for the assessment of creep, a single load in place of two successive loads. The time equivalent corresponds to the time at which a fictitious creep test performed under a constant stress equal to the current stress reaches the current deformation.

2.2.2.1 Equations of equivalent time and creep deformation

The response strength by equivalent is shown in Figure 5 for  $t > t_2$ . Graphical view the equivalent time is such that we have, for  $t > t_2$ . For the answer deformation we get the following mapping as shown in Figure 5:

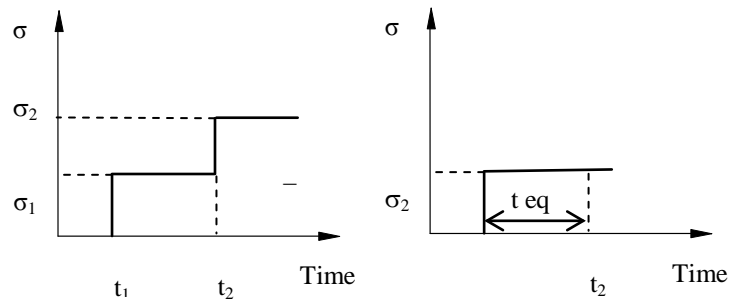

Fig. 5 – Response strength by equivalent time

The equivalent time is given by the equation:

$$\varepsilon_{fl(t_2)} = \frac{\sigma_1}{E} \cdot K_{fl}(t_1) \cdot f(t_2 - t_1) = \frac{\sigma_2}{E} \cdot K_{fl}(t_2 - t_{eq}) \cdot f(t_{eq}) \tag{4}$$

Creep deformation for  $t > t_2$  :

$$\varepsilon_{fl(t)} = \frac{\sigma_2}{E} \cdot K_{fl}(t_2 - t_{eq}) \cdot f(t - t_2 + t_{eq})$$

2.2.2.2 Equations in the general case of n greater strength

The equations in the general case of n greater strength noted  $\Delta\sigma_i$  with i variant from 1 to n and t in the range of time  $[t_i, t_{i+1}]$  can be expressed:

$$t \in c [t_i, t_{i+1}] \quad \varepsilon_{fl(t)} = \frac{\sigma_i}{E} \cdot K_{fl}(t_i - t_{eq_i}) \cdot f(t - t_i + t_{eq_i})$$

$$\text{with } \varepsilon_{fl(t_i)} = \frac{\sigma_i}{E} \cdot K_{fl}(t_i - t_{eq_i}) \cdot f(t_{eq_i})$$

2.2.2.3 After the second equivalent time loading ( $t > t_2$ )

The same data is determinate as before (numerical Application for  $n = 2$  of paragraph 2.2.1 a) , the equivalent time after the second loading ( $t > t_1$ ) and then calculate the creep strain after 300 days and 3000 days.

$$\varepsilon_{fl(28)} = \frac{8}{32000} \cdot K_{fl}(8) \cdot f(28 - 8)$$

$$\varepsilon_{fl(28)} = \frac{8}{32000} \cdot K_{fl}(28 - t_{eq_i}) \cdot f(t_{eq_i})$$

By iteration we get:  $28 - t_{eq} = 22,6$      $t_{eq} = 5,4$  days

$$t = 300 \text{ days} \quad \varepsilon_{fl(300)} = 261,6 \mu m / m$$

$$t = 3000 \text{ days} \quad \varepsilon_{fl(3000)} = 473 \mu m / m$$

Comments

- These values are close to those calculated by the principle of superposition. We recall also that a deformation is a no unit magnitude.
- In the case of real load, the calculation by the method of superposition implies remembering all the steps of charges. This method is expensive computation in time and memory. The interest of the equivalent time method is to avoid these disadvantages since it requires only the current state of stress and strain.

2.3 The creep return

The case where one first applies a strength  $\sigma_1$  at  $t_1$  and discharge  $\Delta\sigma_2$  at  $t_2$  is shown in Fig. 6.

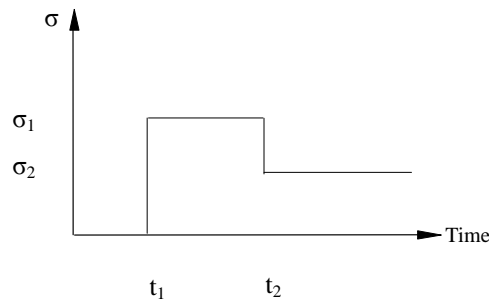

Fig. 6 – History of loading with return creep

Deformation deferred after a time  $t$  is greater than the total of  $t_2$ :

- The creep deformation at time  $t$  due to  $\sigma_2$
- The creep deformation at time  $t_2$  due to the application of  $(\sigma_1 - \sigma_2)$  during the interval  $[t_1 ; t_2]$
- And the return of creep deformation evaluated using the expression

$$\varepsilon_{r1}(t) = \frac{-\Delta\varepsilon_{ic2} \times K_{fl}(t_2) \times f(t_2 - t_1)}{K_r(t_2 - t_1) \times g(t - t_2)} \tag{5}$$

with

$$K_r(t_2 - t_1) = 4. [\log((t_2 - t_1))]^{0.5} \quad \text{if } t_2 - t_1 > 2 \text{ days}$$

$$K_r(t_2 - t_1) = 1 + 0.6(t_2 - t_1) \quad \text{if } t_2 - t_1 \leq 2 \text{ days}$$

$$g(t - t_2) = 1 - \frac{1}{[1 + (t - t_2)]^{0.5}}$$

2.3.1 Calculation of the deferred deformation for  $t = 300$  days

The deferred deformation was calculated for  $t = 300$  days.

Numerical application using same data in table 1 with  $\sigma_1 = 16 \text{Mpa}$   $\Delta\sigma_2 = 8 \text{Mpa}$

$$\varepsilon_{fl} = \varepsilon_1 + \varepsilon_2 + \varepsilon_3$$

$$\varepsilon_1 = \frac{\sigma_1}{E} \cdot K_{fl}(t_1) \cdot f(t - t_1) = 147,3 \text{ (already calculated)}$$

$$\varepsilon_2 = \frac{\sigma_1 - \sigma_2}{E} \cdot K_{f_l}(t_1) \cdot f(t_2 - t_1) = 52,7 \text{ (already calculated)}$$

$$\varepsilon_3 = \frac{\sigma_2 - \sigma_1}{E} \cdot K_{f_l}(t_1) \left[ \frac{f(t_2 - t_1)}{Kr(t_2 - t_1)} \right] \cdot g(t - t_2) = -9,5$$

$$\varepsilon_{fl}(300) = 190,5 \mu m / m$$

With the superposition principle:

$$\varepsilon_1 = \frac{16}{32000} \cdot K_{f_l}(8) \cdot \frac{\sqrt{300-8}}{30 + \sqrt{300-8}} = 294,7 \mu m / m$$

$$\varepsilon_2 = \frac{-8}{32000} \cdot K_{f_l}(28) \cdot \frac{\sqrt{300-8}}{30 + \sqrt{300-8}} = -125,5 \mu m / m$$

$$\varepsilon = \varepsilon_1 + \varepsilon_2 = 169,2 \mu m / m$$

### 2.3.2 Results comparison

The results obtained at  $t = 300$  days by BPEL law will be compared to a strict application of the superposition principle (using the same law for the loading and unloading). We observe what was predictable, that the superposition principle in this case conducted to a much lower final deformation (which corresponds to a stronger return). The formulas give a return of creep deformation of lower order to take into account this aspect: the return of creep of concrete is by far the symmetric flow.

### 2.4 Reloading

The previous history of loading a recharge  $\Delta\sigma_2$  at time  $t_3$  as  $\sigma_1 = \sigma_3$  is presented in Fig 7. The BPEL allows for such history loading the principle superposition with a condition to adopt the creep law for strength positive variations and the creep return law for unloading. Numerical application using same data in table 1 with  $\sigma_1 = 16\text{MPa}$  and  $\Delta\sigma_2 = -8\text{MPa}$

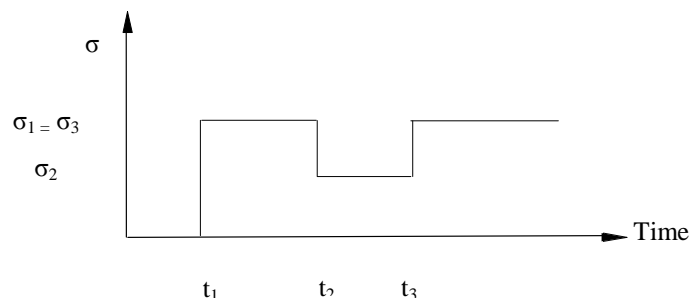

Fig. 7 – Loading a recharge: reloading

#### 2.4.1 Deformation comparison in the period interval $[t_1 ; t]$ .

This deformation will be compared to that which would have been obtained for a constant load equal to 16 MPa in the period interval  $[t_1 ; t]$

Continuous loading (already calculated)  $\varepsilon_{fl} = 294,7 \mu m / m$

Discontinuous loading  $\sigma_1$  until  $t$  (already calculated)  $\varepsilon_1 = 147,3$

$\sigma_1 - \sigma_2$  for  $t_1 - t_2$  (already calculated)  $\varepsilon_2 = 52,7$

Creep return up  $t_3$



$$\varepsilon_3 = \frac{-8_0}{32000} \cdot K_{f_l}(28) \left[ \frac{f(t_2 - t_1)}{Kr(t_2 - t_1)} \right] \cdot g(t_3 - t_2) = -7,8$$

$\sigma_1 - \sigma_3$  de  $t_3$  à  $t$  :

$$\varepsilon_4 = \frac{8}{32000} \cdot K_{f_l}(29) \cdot f(300 - 29) = 124,9$$

$$\varepsilon_{fl} = \varepsilon_1 + \varepsilon_2 + \varepsilon_3 + \varepsilon_4 = 317,1 \mu m / m$$

**2.5 Confrontation of theory with experimental results**

The theoretical and experimental vertical deformation of our horizontal beam subjected to two equidistant centred load will be compared using the theory of Timoshenko [7], the maximum deflection is:

$$f_{max} = \frac{23PL^3}{648EI} + \frac{PL^3}{3GA}sr_z \tag{6}$$

P: centered load; L: span length; E: the longitudinal elastic modulus;  
 I: quadratic moment;  $sr_z$  patches coefficient of transverse shear stiffness G: shear modulus ; A: sheared area

This beam can be considered as constituted of parallel fibres. If we neglect the effect of transverse shear, this amounts to taking  $sr_z=0$  (Kirchhoff formulation, as opposed to the Timoshenko formulation that takes into account the transverse shear stiffness coefficients patches  $sr_z$  (Shear area ratio)

Solid rectangular section  $sr_z=6/5$ . For  $sr_z=0$ , we find the classical expression of beam.

Strength of materials provides us with the theoretical values of the rotations and deflections at any point of the beam and in particular to points A, B, C and D:

$$f_{A-C} = \frac{Px(3x^2 - 2L^2)}{18EI} \qquad w_{A-C} = \frac{P(9x^2 - 2L^2)}{18EI}$$

$$f_{C-D} = \frac{Pl}{6EI} \left( x^2 - Lx + \frac{L^2}{27} \right) \qquad w_{C-D} = \frac{Pl}{6EI} (2x - L)$$

$$f_{D-B} = \frac{P(l-x)}{6EI} \left( x^2 - 2Lx + \frac{L^2}{3} \right) \qquad w_{D-B} = \frac{P(l-x)}{6EI} \left( 2Lx - x^2 - \frac{7L^2}{9} \right)$$

The curvature radius (Fig 8) can be written in Cartesian coordinates  $r = \frac{(1 + y'^2)^{3/2}}{y''}$  but the slope of the deformation is still quite low and we can consider that  $y'$  is small and  $y''$  is negligible.

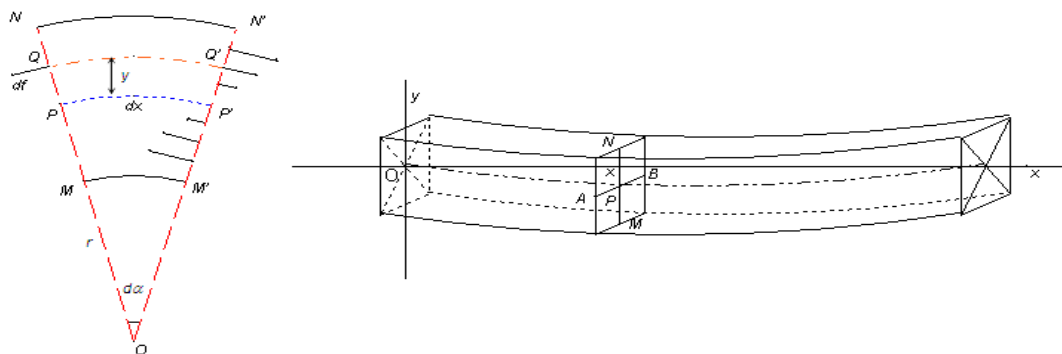

**Fig. 8 – The curvature radius**

A part of the creep is mainly due to the applied stress (Table 2) provides a comparison of the theoretical rotation and deflection to the experimental values.

**Table 2 Comparison of the theoretical rotation and deflection to the experimental values (P=500daN)**

Age j ( days)		Deflection (mm)		Rotation (mm <sup>2</sup> )				
		C	D	A	B	C	D	
		$\frac{5PL^3}{162EI}$	$\frac{5PL^3}{162EI}$	$\frac{PL^2}{9EI}$	$-\frac{PL^2}{9EI}$	$\frac{PL^2}{18EI}$	$-\frac{PL^2}{18EI}$	
Experimental Value	0	F i*	0,765	0,742	8,371	-8,132	4,163	-4,068
		Fv**	0		0			
	300	total	0,765	0,742	8,371	-8,132	4,163	-4,068
		F i*	0,765	0,742	8,371	-8,132	4,163	-4,068
	300	Fv**	1,731		13,532	-12,961	7,157	-7,364
		total	2,496	2,473	21,903	-21,093	11,32	-11,432
Theoretical Value	0	F i*	1,359	1,359	14,82	-14,82	7,41	-7,41
		Fv**	0		0			
	300	total	1,359	1,359	14,82	-14,82	7,41	-7,41
		F i*	1,359	1,359	14,82	-14,82	7,41	-7,41
	300	Fv**	$\varepsilon_{fl(300)} = 272,8 \mu m / m$		-	-	-	-
		total	1,359	1,359	14,82	-14,82	7,41	-7,41

\* immediate \*\* creep deflection

## Conclusion

After having explained the experimental study (presented and discussed in Part A), Part B of the present paper focused on the analytical investigations intended to calibrate existing formulas by means of the strain and deflection measurements obtained in the experimental tests. The following recommendations and conclusions are drawn from this study:

- The method of superposition principle is expensive computation in time and memory. The interest of the equivalent time method is to avoid these disadvantages since it requires only the current state of stress and strain
- The superposition principle conducted to a much lower final deformation (which corresponds to a stronger return). The creep return of concrete is by far the symmetrical creep.
- The BPEL allows when we used a loading-unloading cycle, the use of principle superposition but with different laws in loading and unloading cycle.
- The purpose of the numerical application is to show an overestimation of creep deformation (effect we do not have with the time equivalent method). In the limit by succession of very short loading -unloading cycles application of BPEL led to grossly overestimated deformations.

## Acknowledgments

The authors would like to thank the manufacturer of the GFRP Combar® (Schöck, Baden-Baden, Germany) for providing and supporting this research. The opinion and analysis presented in this paper are those of the authors.

## REFERENCES

- [1]- M.F. Sá, Mechanical and structural behaviour of FRP – Pultruded GFRP elements. Master's Thesis in Structural Engineering. IST, Technical University of Lisbon, in Portuguese, 2007
- [2]- M.F. Sá, A.M. Gomes, J.R. Correia, N. Silvestre, *Creep behavior of pultruded GFRP elements – Part 2: Analytical study*, Compos. Struct. 93(9)(2011) 2409-2418
- [3]- B. Benmokrane, O. Chaallal, R. Masmoudi *Flexural response of concrete beams reinforced with FRP Reinforcing bars*. ACI Struct J. 93(1)(1996) 46–55.
- [4]- Schock Bauteil GmbH Combar, *Design Guideline for Concrete Structures Reinforced with Glass Fiber Reinforced Polymer following the Requirements of DIN 1045-1 and EC2* Issued Germany, 2006
- [5]- R. Aboutaha, *Recommended Design for the GFRP Rebar Combar*, Syracuse University, Department of Civil and Environmental Engineering, Technical Report, USA, 2004.
- [6]- BAEL 1983 : Reglement de calcul du béton armé aux états limites
- [7]- W. Weaver, S.P. Timoshenko, D.H. Young, *Vibrations Problems in Engineering*, Wiley and Sons, 4th Ed., 1974