

**THE NEURAL NETWORK METHODS USE  
IN AUTOMATED SYSTEMS OF SCIENTIFIC RESEARCHES OF HIGH AND CRITICAL TECHNOLOGIES  
IN ENGINE-BUILDING MANUFACTURING**

**S. G. SELIVANOV<sup>1</sup>, S. N. POEZJALOVA<sup>2</sup>**

<sup>1</sup>S.G.Selivanov@mail.ru, <sup>2</sup>Poezjalova@mail.ru

Ufa State Aviation Technical University (UGATU)

*Submitted 2013, July 22*

**Abstract:** The ways of application of artificial neural networks and genetic algorithms methods for optimization of design, perspective and directive technological processes of machine-building production are shown.

**Key words:** optimization; technological processes; the automated system of technological preparation of manufacture; mathematical modeling; neural networks; artificial intelligence.

**INTRODUCTION**

It is known that innovative activity includes:

- performance of research, developmental or skilled and technological works on creation of innovative production, including the new or advanced technological processes intended for practical application;
- activities for advance of innovative production on the internal and world markets;
- technological re-equipment and production preparation for release of innovative production, introduction of new or advanced technological process;
- implementation of tests of the innovative production new or advanced technological process;
- release of innovative production, application of new or advanced technological process;
- preparation, retraining and professional development of shots for implementation of innovative activity;
- activities for carrying out examinations, rendering consulting, information, legal and other services for creation and (or) practical use of the innovative production, new or advanced technological process and other kinds of activity directed on creation of innovations and their introduction in a civil turn.

The concept of the innovative project includes system of the actions providing during the set period of time creation, production and realization of

a new type of production or technology for the purpose of receiving profit or other useful effect.

The innovative projects have to meet the following requirements:

- to contain the offers united by the uniform purpose of creation of innovations;
- to contain technical justification and expediency of implementation of the innovative project;
- to contain the documents confirming novelty and right security of the innovative project;
- to contain an economic justification, including, confirming return of means to the budget of the investor;
- to contain the program of implementation of the innovative project.

All these requirements become feasible in the conditions of use of the automated systems of technological preparation of production (ASTPP). Modern ASTPP even more often develop with use of artificial intelligence techniques, including on the basis of application of artificial neural networks and genetic algorithms.

**OPTIMIZATION OF TECHNOLOGICAL  
PROCESSES DESIGN**

The purpose of such works most often is structural optimization of design technological processes by criteria of a fund savings for production modernization. The application of artificial intelligence techniques in the form of a logic-genetic method [3] for structural optimization of design technological processes consists in use of network counts and

the genetic algorithms are known from the theory of artificial intelligence, for production and development modernization of:

- technological routes by criterion of a minimum of goods turnover for formation of the sheet of technological routes of products;
- route technological processes for optimum design of production structure of cases, shops and enterprise sites.

The algorithm of this method is presented in Fig. 1. Here the phenotype of a chromosome represents a set of values of numbers of shops, otherwise, a production route. For example,  $ch$  (chromosome) = (1 4 3 2) for 4 shops.

At a stage of initialization, formation of initial population, a chromosome check on performance of statements of the problem, thereby it is possible to create the "rational" chromosomes meeting conditions of innovative design.

Estimation of fitness of a chromosome in population consists in calculation of function of fitness, in calculation of total goods turnover.

The selection of chromosomes is made by a roulette method. The method of roulette is rather in detail described in scientific literature [3]. The essence of this method consists in the following: the roulette wheel sector which size is established in proportion to value of function of fitness of this chromosome is compared to each chromosome. Therefore the more value of function of fitness, the is more sector on a roulette wheel and probability of a choice of this chromosome as the parent.

In this algorithm one genetic operator – the operator of crossing (crossover) is used. The single-point crossover which essence consists in a casual choice of a point of crossing (a crossover point) or gap points in which both chromosomes share on two parts is used and exchange them.

Formation of new population is made at the expense of association of parents and descendants. The condition of a stop of work of algorithm – achievement of expected optimum value.

The program is developed for the solution of this task "The chamber of Commerce and Industry" (Fig. 2) which is executed in the environment of MS Visual Studio 2008 programming.

By pressing the «Technological Routes» [3] button there is a program window which allows to make optimization of technological routes by means of a logic-genetic method.

At approbation of this program on the example of optimization of production of the module air heat exchanger the following data were obtained. Such calculations allowed to create subject the closed (specialized) production of the called products that sharply reduced a counter cargo transportation be-

tween platforms of the enterprise and ensured essential economic effect (more than 38,0 million roubles).

By results of optimization of technological routes by criterion of a minimum of goods turnover it is possible to start the solution of tasks on optimization of technological processes. The priority criteria of optimization of development of route charts of design technological processes resource-saving indicators in shops act.

For automation of the solution of a problem of multicriteria optimization of fund savings technological process on the basis of creation of multiple structural model of perspective technological processes it is also offered to use the genetic algorithms realized in the environment of programming of MS Visual Studio 2008. Thus, technological process can be presented in the form of the network count where tops of the count – technological operations of processing, and arches define possibility of their consecutive performance.

In this case design by means of a logic-genetic method of optimum technological processes criteria of optimization have to minimize both sizes of business assets, and sizes of use of funds of operating time of the equipment and workers. The most rationally these funds of time are used at minimization of the piece or piece and calculation time.

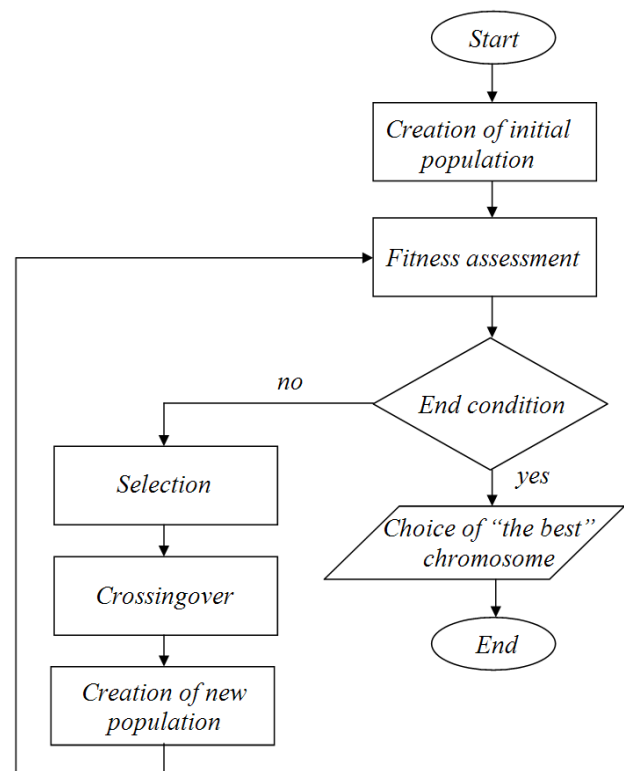

**Fig. 1.** The flowchart of genetic algorithm of finding of an optimum technological route



Fig. 2. The program interface “TPP BP”

Estimation of function of fitness in this case consists in calculation of criterion function which pays off on a method of a resultant indicator of quality. The essence of this method is that private criteria unite in one generalized criterion, and then there is a maximum or a minimum of this criterion. The generalized criterion decides on the help of application of the additive criterion which criterion function receive by addition of rated values of private criteria.

Estimation of function of fitness in genetic algorithm is carried out as follows: the more value of function of fitness, the is more sector on a roulette wheel and probability of a choice of this chromosome as the parent.

Thus, this program allows to optimize design technological processes on the basis of use of a logic -genetic method by criteria of capital investments in the equipment, the areas and piece time [1].

**USE OF JORDAN’S ARTIFICIAL NEURAL NETWORKS FOR OPTIMIZATION OF PERSPECTIVE TECHNOLOGICAL PROCESSES**

For the solution of a problem of multicriteria optimization of perspective resource-saving technological processes in MATLAB system it is possible to use methods of artificial intelligence in the form of recurrent artificial neural networks [6] (Jordan, Elman, etc.), Fig. 3 and 4.

Before beginning optimization procedure by criteria of resource-saving, it is necessary to construct mathematical model of technological process of production of a detail (Fig. 5).

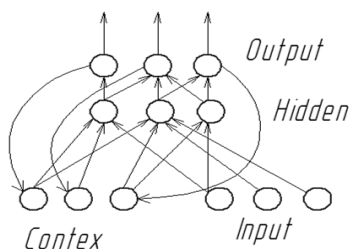

Fig. 3. The Jordan's networks structure

Such model in this case is the multiple network count [2] (Fig. 6) created on the basis of basic factory technology and added with other tops operations which provide change of the plan of the processing, new methods and modes of processing, structure of park of new processing equipment, improvement in structure of other means of technological equipment.

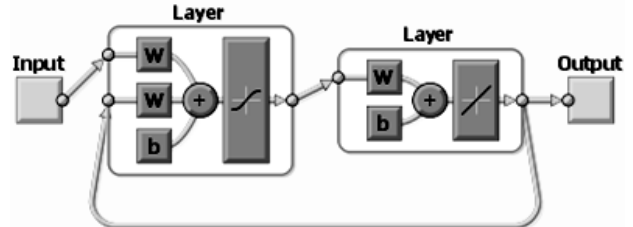

Fig. 4. The Jordan's networks scheme for the solution of a problem of multicriteria optimization of resources savings perspective technological processes in the environment of MATLAB

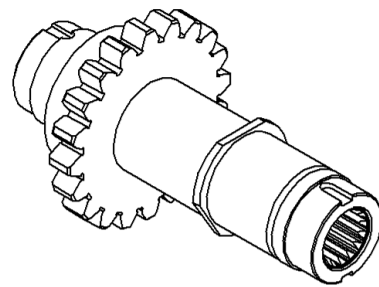

Fig. 5. 3D model of detail-representative "gear wheel"

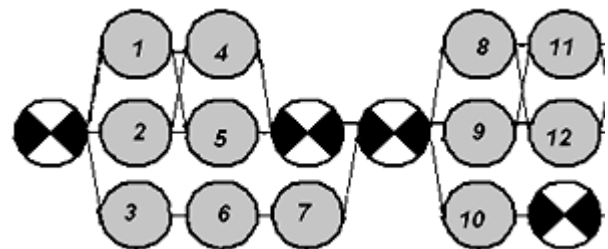

Fig. 6. Fragment of the count of technological process of production of a detail "gear wheel"

For use of a network of Jordan in a problem of multicriteria optimization, also as well as in case of application of genetic algorithms, it is necessary to make linear convolution of input parameters – criteria of optimization (to lead input parameters to dimensionless size on conditions of application of methods of multicriteria optimization).

As parameters of a numerical assessment of perspective technological process in this case the following criteria are used:

- three indicators (the given expenses, piece time of production of a detail, a capital intensity) for which the minimum values are defined,

- one indicator (material efficiency) for which the maximum value is defined.

It is used for providing the maximum savings of materials in perspective technological process of production of a product.

Thus, the considered network method of artificial intelligence allows to carry out multicriteria optimization of perspective resource-saving technological processes that provides economy of production resources.

**OPTIMIZATION OF DIRECTIVE TECHNOLOGICAL PROCESSES ON THE BASIS OF ELMAN'S NEURAL NETWORK**

In innovative projects other appointment, than documentation of perspective resource-saving technological processes [2, 5] have sets of documentation of directive technological processes – they are urged to provide creation and statement on production of new competitive products or equipment of new generations.

For ensuring competitiveness of new products at stages and stages of research and development and skilled and technological works it is recommended to consider as the main criteria of optimization of directive technological processes:

- the highest values of parameters of a technological level of new products which provide directive technological processes, and also
- the smallest labour input of processing or assembly,
- minimum expenses and
- the smallest risk (first of all from marriage at introduction of new technology).

For implementation of multicriteria optimization of directive technological processes by the criteria described above the program MATLAB environment and a Neural Network package is used. The hybrid network is applied to an objective in the form of Elman's recurrent network (Fig. 7) with elements of indistinct logic. The developed software product contains two main parts for definition of optimum directive technological process [1, 3].

The first part of criteria is determined by parameters of a technological level of a product which can be presented in the form of three linguistic variables considering influence of new (directive) technology on improvement of the main parameters of a technological level of a product of:

- technologies which don't influence a technological level of a product, for example, at a size of draft of the engine, a resource, reliability, etc.,
- the technologies having weak impact on a technological level of a product,

- technologies which have strong impact on a technological level of a product [4].

The accepted way of definition of the called criteria of optimization assumes use (Fig. 8) of methods of fuzzy logic (FL) which widely apply in the theory of artificial intelligence. The maximum values of such parameters of quality of a product allow to define a priority of technologies of its production at a choice of methods of processing (assembly) for ensuring competitiveness.

The second part of criteria of the software product (Fig. 8) contains numerical estimates (the *C* are expenses, *T* is piece time and *R* are risks) that allow to use artificial neural networks for multicriteria optimization.

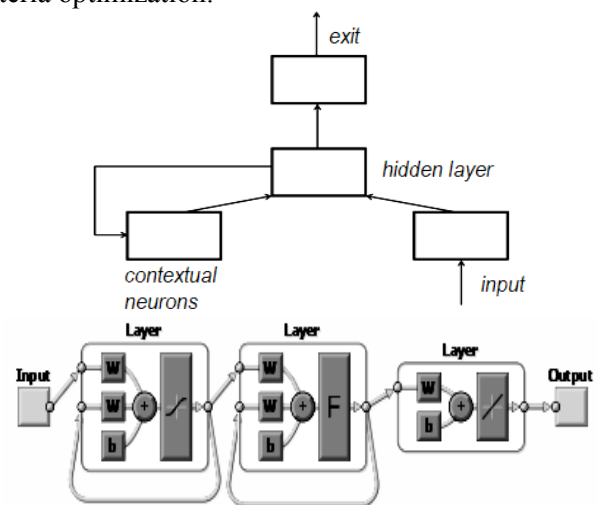

Fig. 7. The structure of a three-layer neural network of Elman for a problem of optimization of directive technological processes

	C,min	T,rub	R	FL
1	81.47	9	0.12	0.213502
2	91.33	6	0.25	0.8875
3	79.85	5	0.2	0.246154

Fig. 8. The structure of the data input table

For use of a network of Elman in problems of multicriteria optimization, also as well as in the cases of use of genetic algorithms considered above and Jordan's artificial neural networks, it is necessary to make in the beginning reduction of input parameters to dimensionless size on conditions of application of methods of multicriteria optimization. This part of works provides use in the environment of method MATLAB linearly – additive convolution [5]. For method realization linearly – additive convolution it is necessary to establish in the beginning the weight of priorities from 0 to 1:

- for labour input in this case the priority 0,35 is appointed;

- for expenses – 0,35;

- for criterion of risk [8, 9] – 0,3.

Let's consider in more detail procedure of use of a neural network of Elman for multicriteria optimization of directive technological processes in engine-building.

Process of training of the created neural network of Elman in MATLAB system is graphically shown in Fig. 9 where dependence of time (quantity of the periods of training) and a mistake (an average square mistake) calculation is shown.

Working off considered above a package of applied programs of multicriteria optimization of directive technological processes is considered on the

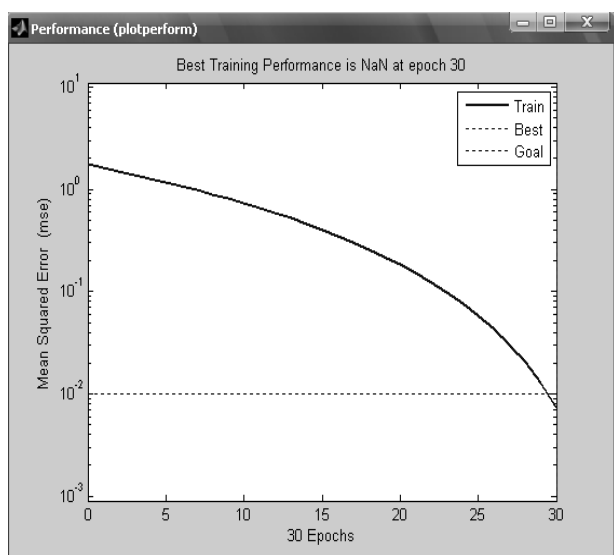

Fig. 9. The schedule of training of a neural network of Elman

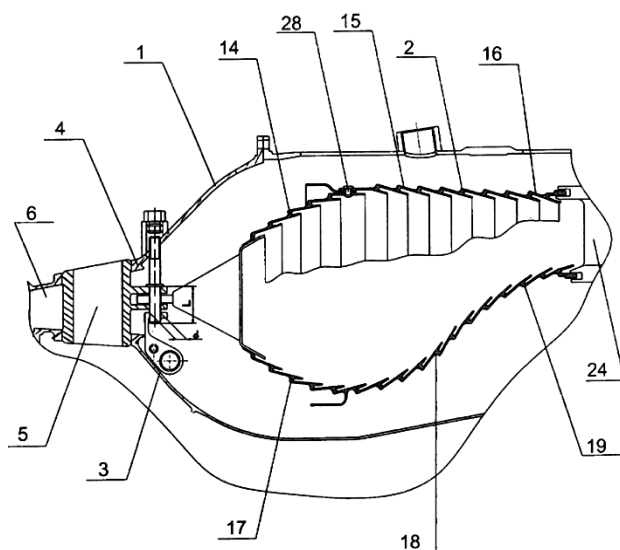

Fig. 10. General view of a diffuser of the combustion chamber of the aviation engine (the position 5 is detail "Rack")

example of optimization of directive technological processes of production of details of diffuser of combustion chambers of aviation engines (Fig. 10). The position 5 in Fig. 10 designated a combustion chamber detail "Rack", directive which technological process is optimized in this case.

For the solution of a considered optimizing task also as well as in cases of use of genetic algorithms or Jordan's artificial neural networks [6, 8] it is necessary to construct the multiple network count of directive technological processes. Data of the count are entrance data for the software product (Fig. 8).

On the basis of data of the count various options of directive technological processes which were divided into 3 groups depending on a type of processing are calculated are the directive technological processes based on the soldering, argon-arc welding and electron beam welding that allowed to choose Pareto-optimal option of directive technological process by the criteria called above taking into account the established dependences [7, 9].

Thus, use of the hybrid computing system of artificial intelligence on the basis of Elman's neural networks with elements of indistinct logic provides multicriteria optimization of directive technological processes of engine-building production.

## CONCLUSION

It is established that the methods of development of innovations considered above in the form of design, perspective and directive technological processes meets the requirements of optimization of innovative are design. Such development can be added, continuing researches by means of means of imitating modelling of innovative projects.

## REFERENCES

1. S. G. Selivanov and S. N. Poezjalova, "The neural-fuzzy management method of development of high and critical technologies in engine-building manufacture," (in Russian), *Innovacii*, no. 10, pp. 98-104, 2011.
2. S. G. Selivanov and S. N. Poezjalova, "The innovative regularities of development of the aircraft equipment and technologies," (in Russian), *Innovacii*, no. 2 (124), pp. 63-70, 2009.
3. S. G. Selivanov, V. V. Nikitin, S. N. Poezjalova, and M. V. Selivanova, "Use of methods of an artificial intellect in technological preparation of machine-building manufacture," (in Russian), *Vestnik UGATU*, vol. 14, no. 1 (36), pp. 87-97, 2010.
4. S. G. Selivanov and S. N. Poezjalova, "The method of mathematical modeling and structural optimization of uniform technologies in innovative projects," (in Russian), *Vestnik UGATU*, vol. 12, no. 2 (31), pp. 93-102, 2009.
5. S. G. Selivanov and S. N. Poezjalova, "The automated system of scientific researches high and critical technologies in engine-building manufacture," (in Russian), *Vestnik UGATU*, vol.13, no. 1 (32), pp. 112-120, 2009.

6. S. G. Selivanov, S. N. Poezjalova, O. A. Borodkina, and K. S. Kuznetsova, "The recurrent networks and methods of design technological processes optimization in ASTPP of machine-building productions," (in Russian), *Vestnik UGATU*, vol. 15, no. 5 (45), pp. 36-46, 2011.
7. S. G. Selivanov and S. N. Poezjalova, "Automated system of scientific researches high and critical technologies in engine-building manufacture," in *Proc. 11th Int. Workshop on Computer Science and Information Technologies CSIT'2009*, Crete, Greece, 2009, vol. 2. pp. 62-66.
8. S. G. Selivanov and S. N. Poezjalova, "The neural-fuzzy management method of development of high and critical technologies in engine-building manufacture," in *Proc. 12th Int. Workshop on Computer Science and Information Technologies CSIT'2010*, Moscow – St. Petersburg, 2010, vol. 1. pp. 102-107.
9. S. G. Selivanov and S. N. Pojezalova, "The intellectual system of development of directive technological processes in mechanical engineering," in *Proc. 13th Int. Workshop on Computer Science and Information Technologies CSIT'2011*. Germany, Garmisch-Partenkirchen, Sept. 27 – Oct. 2, 2011, vol. 1, pp. 80-83.

#### ABOUT AUTHORS

**SELIVANOV, Sergey Grigorievich**, Prof., Dept. of technology of mechanical engineering. Dipl. Mechanical engineer (UAI, 1970). Dr. of Tech. Sci. (Technology of mechanical engineering, MOSSTANKIN, 1991). Prof., Honored worker of science of RB.

**POEZJALOVA, Svetlana Nikolaevna**, assistant, the same Dept., Cand. of Tech. Sci. Dipl. Master of equipment and technology (Equipment and automation of machine-building productions, UGATU, 2009). Cand. of Tech. Sci. (Automation of technological processes and productions, UGATU, 2012).