

Design and Simulation of Horn Antenna in x-Ku Band for Satellite Communications

S. Gowri Shankar¹, K. Viswavidhan Reddy² and K. Vishnuvardhana Reddy³

¹Department of Telecommunication Engineering, R V College of Engineering, Bangalore India

²Department of Telecommunication Engineering, R V College of Engineering, Bangalore India

³Faculty of Integrative Sciences and Technology (FIST), Quest International University Perak, Ipoh, Malaysia

Article Info

Article history:

Received Nov 10th, 2014

Accepted Nov 25th, 2014

Publication Nov 28th, 2014

Keyword:

Cross-pole isolation,
HFSS,
Horn Antenna,
Return loss.

ABSTRACT

Horn antennas are widely used antennas in satellite applications mainly because of their physical robustness and capability to operate at high frequencies. In this work an attempt has been made to design a pyramidal horn antenna along with associated waveguide to operate in X-Ku band (9.5 to 14.5 GHz). The design was simulated using High Frequency Structure Simulator (HFSS). HFSS is a widely used tool when it comes to design and simulation of any antenna system. Initially by using design formulas, the dimensions of the horn structure and waveguides are found and then they are fed into HFSS to simulate in the mentioned frequency band. The performance parameters like return loss, radiation pattern, directivity and cross-pol isolation were considered for the simulation. Finally, with this design we will be able to reduce the operation costs in launching any communication satellites for broadcasts.

Copyright © 2014 International Journal of Research in Science & Technology
All rights reserved.

Corresponding Author:

K Viswavidhan Reddy

Department of Telecommunication Engineering,

R V College of Engineering,

Bangalore India

Email Id: viswavidhank@rvce.edu.in

I. INTRODUCTION

X-Ku band is intermediate to X and Ku band frequency, notably for fixed and broadcast services, and for specific applications such as NASA's Tracking Data Relay Satellite [1] used for both space shuttle and ISS communications. X-Ku -band satellites are also used for backhauls and particularly for, the satellite from remote locations and back to a television network's studio for editing and broadcasting. Earlier days Direct-Broadcast Satellite (DBS) is a term used to refer satellite television broadcasts intended for home reception. Now a day's DBS has been replaced with Direct-To-Home (DTH). This has initially distinguished the transmissions directly those are intended to home viewers,

from cable television distribution services that are sometimes carried on the same satellite.

The C band frequency range has one significant problem, that is the frequency region has been overloaded due to the same frequency assigned to terrestrial microwave radio communication systems [2]. There are emerging numbers of microwave systems located all over the world and they carry a large volume of commercial communications. Consequently, the VSAT locations are restricted in order to prevent interference with the terrestrial microwave communication systems. As mobile phones are being used everywhere in world and all over Africa as well, the use of C-Band in future would certainly increase. At present, the C Band is widely being used.

The X-Kuband frequency range is assigned and particularly used by the satellite communication systems, and thus we can eliminate the problem of interference with microwave systems. Smaller earth station antennas and RF units are allowed by the Ku-band to be installed at VSAT locations, due to the higher power levels at new satellites.

To avoid interference with the terrestrial microwave systems, the power of Ku-band is not equivalently limited with C-band, and the power of its uplinks and downlinks can be increased [3]. Due to this higher power, smaller receiving dishes are being translated and points out a generalization between a satellite's transmission and a dish's size [4]. As the power increases dish's size decrease, because the purpose of the dish element of the antenna is to collect the incident waves over an area and focus them all onto the antenna's actual receiving element. A smaller dish size and a X-Ku band system's freedom from terrestrial operations simplify finding a suitable dish site. For the end users X-Ku band is generally cheaper and enables smaller antennas (both because of the higher frequency and a more focused beam). X-Ku band is also less vulnerable to rain fade than the Ka-band frequency spectrum.

L-band ranging between 1-2 GHz is relatively a low frequency band and is easier to process, with less sophisticated and less expensive RF equipment. L-Band is also used for low earth orbit satellites, military satellites, and terrestrial wireless connections like GSM mobile phones [5]. For satellite TV, L-band is also used as an intermediate frequency, where the Ku or Ka band signals are down-converted to L-band at the antenna LNB, to make it easier to transport from the antenna to the below deck, or indoor equipment [5]. Since there is not much bandwidth available in L-band, it is a costly material.

II. MOTIVATION

Essentially the design of horn antennas are not straight forward in nature, meaning the equations vary for different conditions and they are used as feeds for larger systems instead of standalone antennas. So, this work is to see, if using horn antennas as independent antenna keeps up with the performance or not. Also, this work has motivated us to learn one of the most antenna designing tool that is HFSS. Horn antennas are used mainly in satellite communication as they are structurally very strong and the main application of this X-Ku band being for direct to home television broadcasts. By using alternative frequency bands instead of single bands like C or L, would help to increase the quality of service for increasing television subscribers.

The objectives of this work is to design a Horn antenna that operates for 9.5 to 14.5 GHz (X-Ku band) and achieve a target return loss better than 20dB, Cross-pol isolation in the range of 27 to 30 dB and antenna gain close to 24 dB.

III. INTRODUCTION TO WAVEGUIDES

Waveguides are designed with hollow metallic pipes used for carrying microwave signals from one point to other. The transmission characteristics of a waveguide are like a high pass filter. At frequencies higher than cut off frequency, the EM wave is propagated in longitudinal direction. The fundamental wave of a waveguide is the natural wave with lowest cut off frequency. In an antenna design of waveguide, put it as one end and load at the other end. In wave guides, TEM mode does not exist so the wave propagates in a waveguide primarily in non TEM mode, where the mode is either the electric or the magnetic field component in the direction that exist. The non TEM modes are of two types- TE mode where there is no E-field component in the direction of propagation and TM mode where there is no H-field component in the direction of propagation. The cut off frequency for the waveguide can be found by the given equation (1).

$$f_c = \frac{1}{2\pi\sqrt{\mu\epsilon}} \sqrt{\left(\frac{m\pi}{a}\right)^2 + \left(\frac{n\pi}{b}\right)^2} \quad (1)$$

In a rectangular waveguide for a particular mode in wave guiding structure, there is a maximum free space wavelength at which the propagation just stops. This is called cut off wavelength and this mode is called dominant mode. The dominant mode for cut off wavelength is TE₁₀. For this work since we operate on X-Ku band of frequency, we chose WR-75 waveguide. WR waveguide system is EIA (Energy information administration) of US using a WR designator to indicate size. The WR size is number is taken from internal measurement in mils of wider size of the waveguide. So, WR-75 corresponds to 0.75 X 0.375 in.

IV. HORN ANTENNAS

Horn antenna is a flared out waveguide. The function of the horn is to produce a uniform phase front with a larger aperture than that of a waveguide and hence greater directivity [6]. Horn antennas are popular in the microwave band (above 1 GHz). Horns provide high gain, low Voltage Standing Wave Ratio (VSWR) (with waveguide feeds), relatively with wide bandwidth, and they are not difficult to make [7]. Three basic types of rectangular horns exists. The rectangular horns are ideally suited for rectangular waveguide feeders. The horn acts as a gradual transition from a waveguide mode to a free-space mode of the EM wave [8].

Three types horn antenna which utilize rectangular geometry are

1. E- Plane sectorial horn antenna,
2. H-Plane sectorial horn antenna and
3. Pyramidal horn antenna.

If the horn flare only the E-plane dimension and the broad wall of the waveguide unchanged it is called an E-plane sectorial horn. If the horn serves to flare the H-plane dimension and leaves narrow wall of the waveguide unchanged it is H-plane sectorial horn antenna. When both the waveguide dimensions are flared it is referred to as a pyramidal horn antenna as shown in Fig. 1.

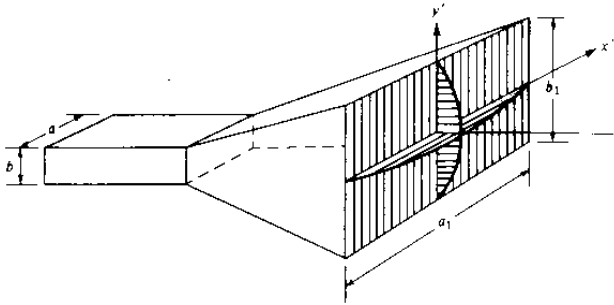

Fig. 1 The standard pyramidal horn antenna

V. DESIGN AND IMPLEMENTATION

HFSS is a high-performance full-wave Electro-Magnetic (EM) field simulator for arbitrary 3D volumetric passive device modelling that takes advantage of the familiar Microsoft Windows Graphical User Interface (MW GUI). It integrates simulation, visualization, solid modelling, and automation in an easy-to-learn environment [9]. HFSS employs the Finite Element Method (FEM), adaptive meshing, and brilliant graphics [10] and it can be used to calculate the parameters such as S parameters, resonant frequency and fields. Ansoft has pioneered the use of the Finite Element Method (FEM) for EM simulation by implementing technologies such as tangential vector finite elements, adaptive meshing, and Adaptive Lanczos-Pade Sweep(ALPS) [11].

The following procedure is used for the design of the said horn antenna with intended specifications for the simulation:

- Initially started with the design of WR-75 waveguide and simulated it on HFSS to know the design process in the tool.
- Based on the formulas that will be further mentioned, the dimensions of horn aperture and height was found.
- The measured design was implemented on the HFSS tool along with the corresponding waveguide.
- The design was further optimized by reducing the size of air box or boundaries to reduce simulation time on HFSS.
- More changes were done in frequency settings and sweeps to get better results.

- After simulation the return loss, radiation pattern, cross-pol isolation and directivity were taken into consideration and captured.

A. Design of Horn Antenna

The design equations were referred from [12], which was clear with all the steps involved. Below Fig 2 and 3 indicates the dimensions that are required to design the horn antenna. Where A is broad side of aperture and B is narrow side of aperture and 'a' is broad side of waveguide feed and 'b' us narrow side of waveguide feed.

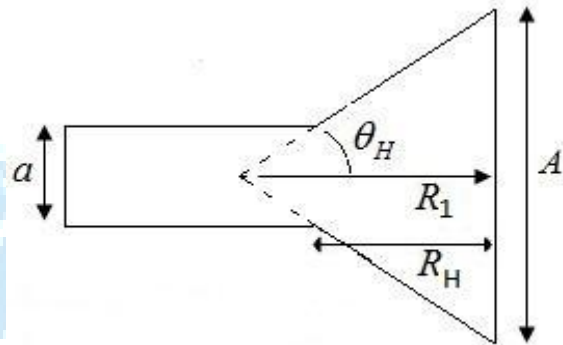

Fig. 2 Broadside dimensions.

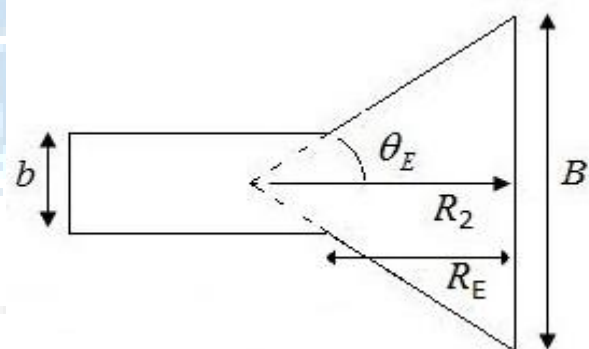

Fig.3 Narrow side dimensions.

We started with the fourth degree Equation (2) to find broadside dimension A.

$$f(A): A^4 - aA^3 + \frac{3\lambda^2 bG}{8\pi\epsilon} A - \frac{3\lambda^4 G^2}{32\pi^2 \epsilon^2} = 0. \quad (2)$$

We substituted the values for equation from WR-75 waveguide as $a=0.01905$ mm, $b=0.009525$ m, ϵ is aperture efficiency of 50%, λ is wavelength at center frequency of 12 GHz which is 0.025m and G is antenna gain of 24dB.

Solving the above equation is very complex, so further simplifications were taken from [12] which involves using numerical methods like bisection methods to solve the equation. The bisection method is based on intermediate value theorem, which states that if a continuous function f has opposite signs at some $x=a$ and $x=b(>a)$, that is, either

$f(a1)<0$, $f(a2)>0$ or $f(a1)>0$, $f(a2)<0$, then f must be 0 somewhere on $[a,b]$. The solution is found by repeated bisection of the interval and in each iteration picking the half, which also satisfies sign conditions. We used MATLAB to code a program based on the equation to run several iterations until the function value returned zero for that point. Since this bisection method requires two initial values and these were taken from [1] that gave us expressions (3) and (4) to find initial $a1$ and $a2$.

$$a1 = \lambda \left(\frac{G}{2\pi} \right)^{0.5} \tag{3}$$

$$a2 = \lambda \left(\frac{G}{\pi} \right)^{0.5} \tag{4}$$

So, by running almost 20 iterations of bisection method, we have got A as 0.15180919 and on 25 iterations A was 0.15180922m. Finally we take A as 0.1518m and using equation (5) we got B as 0.1208m

$$B = \frac{\lambda^2 G}{4\pi\epsilon A} \tag{5}$$

On further testing the values of aperture size A and B on standard gain formula (6) we got as 24.43 dB.

$$G = \frac{4\pi AB\epsilon}{\lambda^2} \tag{6}$$

Now, to find $R1$ and $R2$ we use the equation (7) and (8) that resulted in 0.32 m and 0.30 m respectively.

$$A = (3\lambda R_1)^{0.5} \tag{7}$$

$$B = (2\lambda R_2)^{0.5} \tag{8}$$

We have two equations to find horn antenna height so here we use it to verify to get same values from equation (9) and (10) that results in 0.28m.

$$R_H = \frac{(A - a)R_1}{A} \tag{9}$$

$$R_E = \frac{(B - b)R_2}{B} \tag{10}$$

Finally we find the dimensions of Horn antenna as $A=15.18$ cm, $B=12.08$ cm, $a=1.905$ cm, $b=0.9525$ cm, and height=28 cm. The HFSS design of horn antenna based on the above values and they are formed using perfect electrical conductor is as shown in the below Fig. 4.

The Fig. 5 shows boundary selected for above antenna which is an air box. It is shaped very similar to horn antenna

with all enclosed sides at a distance of $\lambda/4$ so as to realize the radiation pattern of the structure and also to reduce computing time since the RAM memory was limited in our machine to simulate.

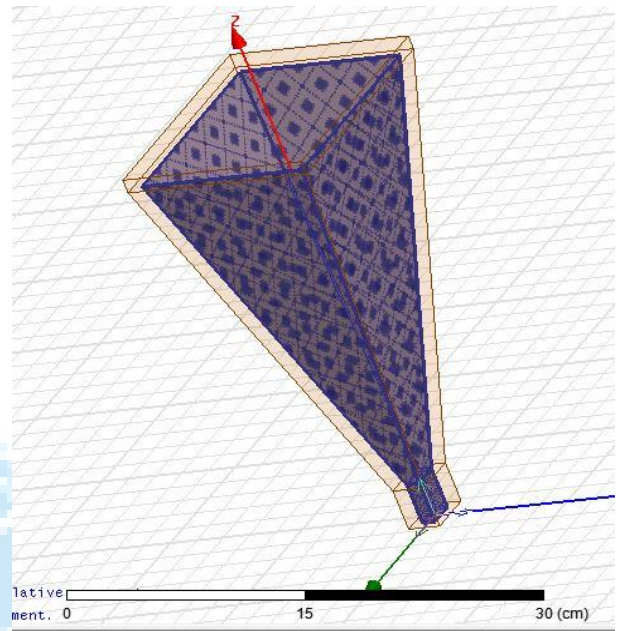

Fig. 4 Horn antenna implementation on HFSS

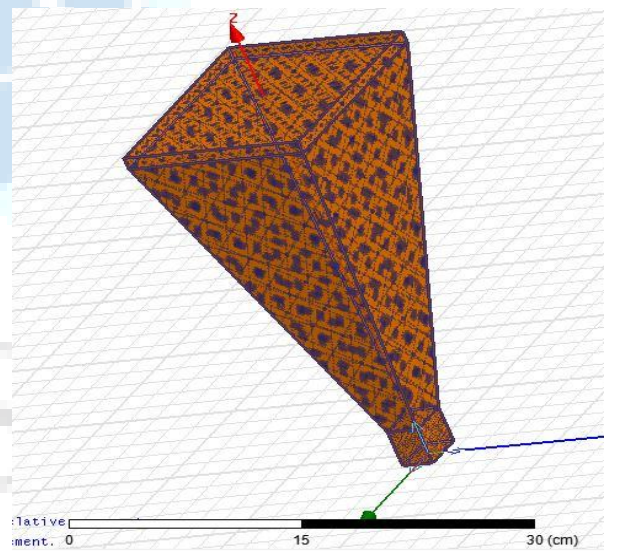

Fig.5 Horn antenna air box boundary implementation on HFSS.

Then we assign a port to the waveguide feed for the horn antenna as described in Fig. 6.

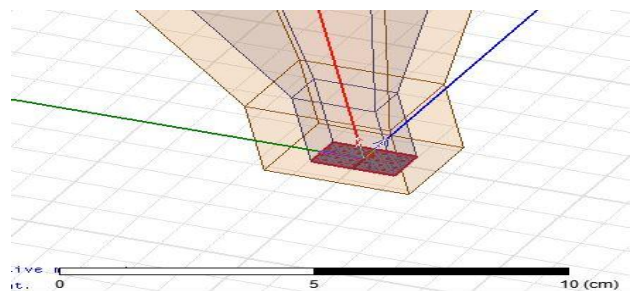

Fig. 6 Horn antenna excitation for feed on HFSS

VI. RESULTS

In this section we compile the results obtained on repeated simulations using HFSS. Fig. 7 shows the return loss plot spanning between frequency 9.5 GHz and 14.5 GHz and it can be found that all maintain less than -25 dB which satisfies one of the objective of return loss better than -20 dB.

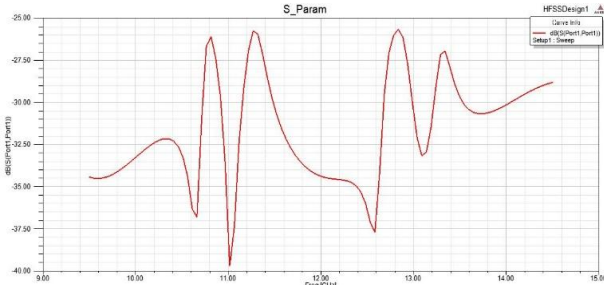

Fig. 7 Horn antenna return loss

Fig. 8 representing the 3D polar plot of radiation pattern of designed horn antenna. Note that the scale indicates achieved gain of 23.44dB which is close to the intended gain to achieve.

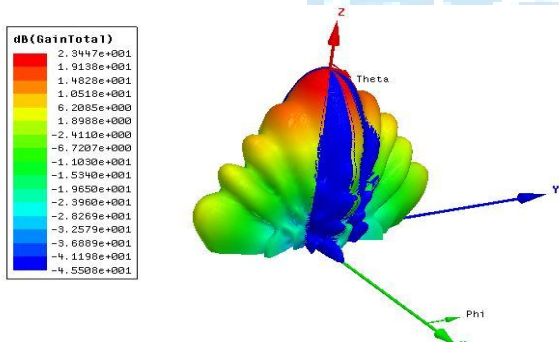

Fig. 8 Horn antenna radiation pattern

The below Fig. 9 is the 2D plot of radiation pattern for better understanding and note that there is marker to indicate the gain at antenna foresight. The thicker line is to indicate the azimuth 0 degree at 12 GHz frequency.

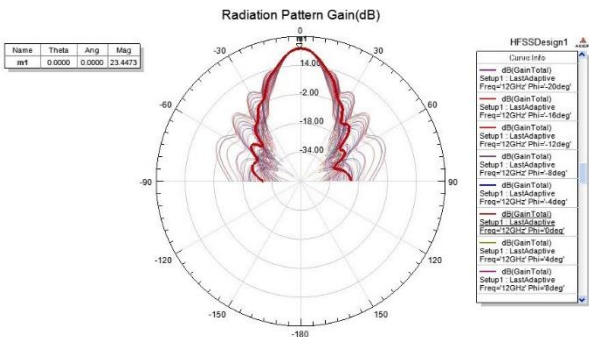

Fig. 9 Horn antenna radiation pattern in 2D

The Fig. 10 is a plot of gain versus theta or elevation angle to observe the side lobe levels for the designed antenna at 0 degree azimuth in 12 GHz frequency highlighted by

thinner line. The parameter side lobe is low and is considered as optional parameter in our work.

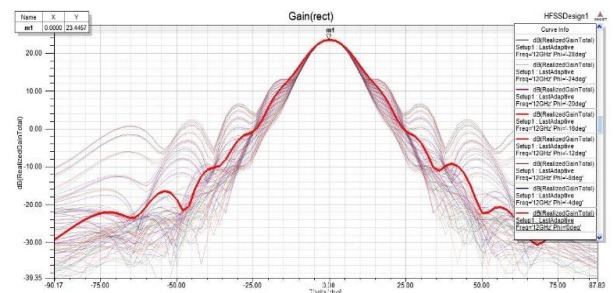

Fig. 10 Gain plot in 2D.

The Fig. 11 shows the cross-polar isolation, it is plot of gain LHCP (Left Hand Circular Polarization) and RHCP (Right Hand Circular Polarization) versus theta (elevation angles) which could be defined as isolation between orthogonal components of polarization. This isolation must be more and helps to use antenna simultaneously in 2 bands to transmit and receives without any interference with each other. Markers has been placed in Fig. 11 and it could be observe that difference between marker 1 and marker 2 gives cross-pol isolation of 28.5458 dB. Note that this parameter too meets the design objective to have it in between 30 to 37 dB.

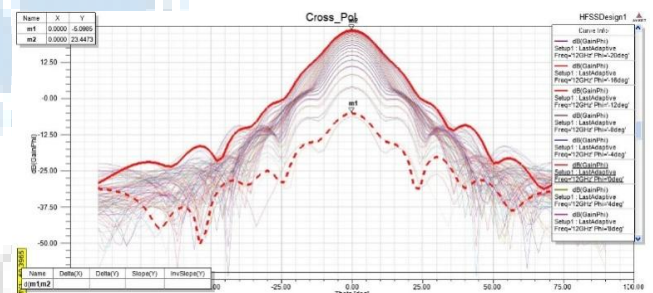

Fig. 11 Cross-polarization plot on Gain in LHCP and RHCP vs theta.

Finally in Fig. 12 we show the plot of directivity vs elevation angle (theta), which shows the side lobe levels and the antenna pattern for different theta angles.

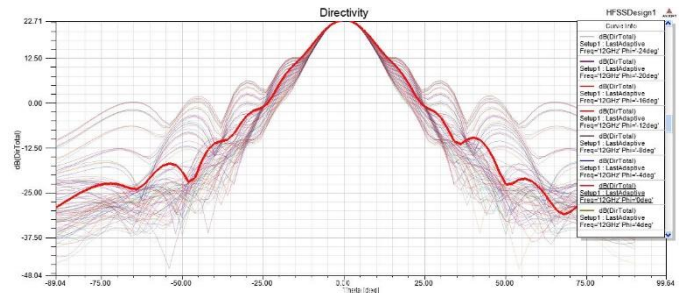

Fig. 12 Directivity vs theta.

VII. CONCLUSION AND FUTURE SCOPE

Successfully modelled the pyramidal horn antenna operating in X-Ku band frequency. Resulting in a gain of 23.44 dB, return loss less than -25 dB and cross-pol isolation of 28.54 dB and plotted associated radiation patterns. It can be found that all design objectives has been met very well. Valuable insight on design using Ansoft HFSS tool was gained and technically understood the methods and procedures for optimizing the design. Future scope could include the physical implementation of the designed antenna and testing them. Also Ortho mode transducers could be designed to improve the antenna to operate in dual band without any interference.

REFERENCES

- [1] <http://www.spcamerica.com/services/repair-services/>
- [2] <http://www.level421.com/index.php?id=1721>
- [3] Jackson.T., Guo chen., Larry Cronise., Peter Hou., Barre. L., Edmund. L., Prakash. H., Rajesh. J., Russel. K., Arul. T., "Method and apparatus for integrated waveguide transmit-receive isolation and filtering", EP20,110,178,059, October. 3, 2012.
- [4] [http://www.scribd.com/doc/50549011/compact-Micro-Strip-Band -Stop-Filter](http://www.scribd.com/doc/50549011/compact-Micro-Strip-Band-Stop-Filter).
- [5] http://www.marinesatellitesystems.com/index.php?page_id=101
- [6] Jagdish. M. Rathod., and Y.P.Kosta., "Development of Feed for Parabolic Reflector Antenna", *International Journal of Engineering and Technology.*, Vol. 1, No. 1, pp. 88-91., April, 2009.
- [7] http://www.electronicsonline.com/CircuitBook/Antenna/Microwave_Antenna/13963.html.
- [8] Vishal. Ohri, Ozair. Amin, Hiruy. G, Benjamin. D, " Microwave Horn Antenna Design and Test System", *San Jose State University*, 2003.
- [9] Alak Majumder, " Design of an H-shaped Microstrip Patch Antenna for Bluetooth Applications ", *International Journal of Innovation and Applied Studies*,ISSN 2028-9324., Vol. 3 No. 4., Aug. 2013., pp. 987-994.
- [10] Parul Dawar, " Design and Simulation of Magic Tee and Ring Hybrid Coupler using Ansoft HFSS ", *IJCST*, Vol. 2, Issue. 1, March 2011.
- [11] Otman El Mrabet, "High Frequency Structure Simulator (HFSS) tutorial " , 2005-2006.
- [12] John F Aurand, "A New Design Procedure for optimum gain pyramidal horns", *Microwave Physics Division*, Sandiaa National Laboratories.