

# ACTIVE NUMERICAL VEHICLE ACCELERATION CONTROL ALONG ACCELERATION FUNCTION WITH MAXIMUM ENGINE TORQUE EFFICIENCY

Ivan Dunderski<sup>1</sup>, M.Sc. ME, Lecturer

UDC: 629.331.5; 62.529: 559

## 1. INTRODUCTION

Vehicle and engine development is a continuous process which focuses on improvement of vehicle dynamic characteristics, increase of engine torque and power and reduction of energy requirements for vehicle motion. Increase of performance and reduction of energy consumption are opposite requirements resulting in modern vehicles being equipped with mechatronic systems that control vehicle motion dynamics, engine and transmission operation.

Special attention is directed toward control of amount and composition of the exhaust gases produced in the combustion process in the engine and its impact on the environment. Operation of Otto and diesel engine is regulated by electronic control unit (ECU), which optimizes fuel consumption and exhaust gas composition. In an ideal (stoichiometric) combustion of the mixture, the products of a chemical reaction are carbon dioxide (CO<sub>2</sub>) and water (H<sub>2</sub>O).

Carbon dioxide is a non-toxic gas, found in mixture of gases [1,2], which creates the greenhouse effect. The only way to reduce the amount of CO<sub>2</sub> in the exhaust gases produced by hydrocarbon fuels combustion is to reduce fuel consumption.

During mixture combustion in the engine, additional inevitable chemical reaction products occur, which are carbon monoxide (CO), unburnt hydrocarbons (HC) and nitrogen oxides (NO<sub>x</sub>) in Otto engine and particles of carbon (C) in diesel engine. These substances are toxic. Their conversion into non-toxic substances is carried out catalytic converter and particle filter.

On the other hand, the fuel consumption is greatly influenced by vehicle motion. Vehicle motion depends on driver's skill and desire to adapt their driving to traffic and road conditions. The vehicle generally moves with variable velocity.

While moving vehicle at a constant speed,  $v=const$ , minimal energy must be invested to overcome the resistance movement. Inertial resistance, related to the acceleration does not exist, because the  $dv/dt=0$ .

While moving vehicle that accelerates, fuel consumption is very dependent on the magnitude of acceleration  $a$  and rate of change of acceleration  $\dot{a}=da/dt$ . Inertial resistance is present. All members in the power balance equation, except air resistance, include mass, which acceleration may take up to 40% of total fuel consumption, during city ride [2].

Inertial resistance features acceleration and masses that both rotate and translate.

In order to save fuel, it's necessary to control the way vehicle accelerates and to reduce vehicle, engine and transmission mass.

---

<sup>1</sup> Ivan Dunderski, MSc, ME, lecturer, School of Electrical Engineering and Computer Science Applied Studies, University of Belgrade, [ivand@viser.edu.rs](mailto:ivand@viser.edu.rs)

Mass reduction is issue of design, but vehicle acceleration control must be achieved in the interaction with the driver. The technical part of interaction incorporates two components:

- Reduction of engine torque
- Delay in throttle response

The magnitude of acceleration  $a=dv/dt$  is controlled, by reducing engine torque. Engine speed, torque and throttle functional relations are redefined and remapped. Engine computer is reprogrammed. This saves fuel because the less torque requires less fuel per engine cycle. Disadvantage: Loss of dynamical characteristics of vehicle.

Delay in throttle response controls the rate of change of acceleration  $\dot{a}=da/dt$ . Throttle to accelerator pedal functional relation is redefined and electronic accelerator pedal is reprogrammed.

Avoiding rapid acceleration changes saves fuel, because they require additional amount of fuel and rich mixture,  $\lambda < 1$ , in order to speed up combustion. Exhaust gas composition is worsened.

*Disadvantage: Loss of drivability*

*Torqueses are reduced via driving modes [3].*

Figure 1 shows driving modes for vehicle „Subaru Impreza“, made by vehicle manufacturer in Japan: „Intelligent“, „Sport“ i „Sport Sharp“.

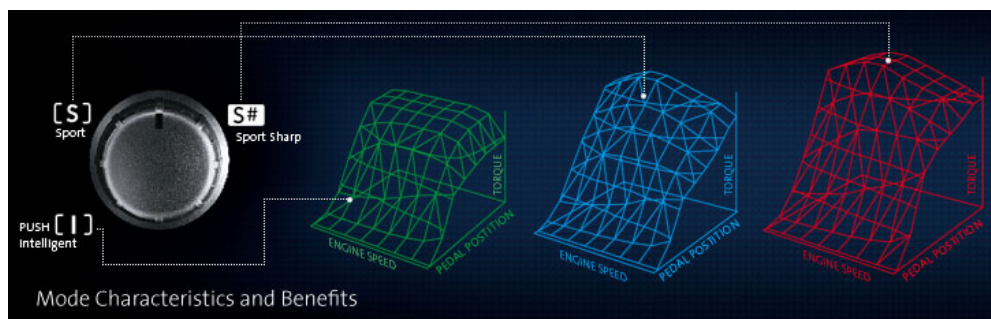

**Figure 1:** Driving mode selection [3]

*Engine torque to accelerator pedal and engine speed mapping*

Mode „Sport Sharp“, „S#“ is source engine operating mode. Mode „Sport“, „S“, is very similar to source mode in terms of mapping shape, but torques for same accelerator pedal position are reduced. Mode „Intelligent“, „I“ continues with further torque reduction, in addition with surface flattening in area of maximum engine torques.

Comparison of engine torques in relation to driving modes is shown in Figure 2.

Engine is turbo-charged, which allows constant torque over wide range of engine speed.

The maximum torque  $T$  reduction is the greatest while using the most conservative mode „Intelligent“. Consequently, loss of power  $P=T\omega$  as a product of torque  $T$  and engine speed  $\omega$ , is also the greatest.

„Intelligent“ mode is suitable for city ride, where vehicle speeds  $v$  are low and the road is mostly horizontal. Acceleration  $a$  and its rate of change  $da/dt$  may be small. The need for power  $P$  for overcoming drag resistance  $R_{drag}$  is low, since vehicle speeds are also low.

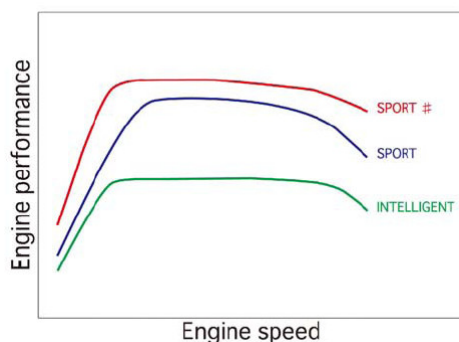

**Figure 2:** Engine torques for „Intelligent“, „Sport“ i „Sport Sharp“ driving modes [4] Accelerator pedal response is slowed by reprogramming Electronic Throttle Control (ETC).

Figure 3. illustrates accelerator pedal response to pressure. In all three modes the accelerator pedal is fully pressed (100%).

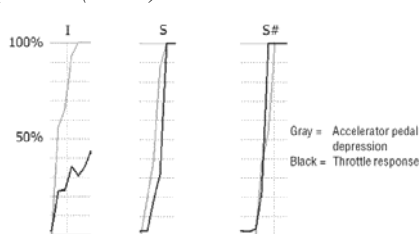

**Figure 3:** Accelerator pedal response [5]

Accelerator pedal response delay in „I“ mode is large and nonlinear, while delay in „S“ mode is small and linear. In „S#“ mode, response is linear and ETC catches up with accelerator pedal pressure around 40% of its full movement. Further ETC response goes even before current pedal pressure: Drivability is additionally increased. Similar idea is used for braking pedal, when driver receives aid in rapid boost of maximum pressure in braking installations. The Bosch company is continuously upgrading this system.

Other vehicle manufacturers around the world are following the same idea for fuel saving. Names for the individual driving modes are different. Mode which corresponds to the "Intelligent" mode is usually called "ECO/Economic", and the original mode is "Standard."

Driver's impact on fuel consumption is significant. The vehicle manufacturer "Ford Focus" from the United States (European branch) states that interaction with the driver alone can result in fuel savings of up to 24%. [6].

The vehicle does not have technical solutions in terms of reprogramming torque maps and response to the accelerator pedal delays. Instead, a pure software solution is applied to monitor and collect ride data. It records the engine speed, vehicle speed, and accelerator pedal position, the position of the clutch pedal, selected gear and engine operating temperature. The collected data are analyzed and processed.

The result is evaluation of driving style, which is reported to the driver. Proposal of solution for fuel-saving is in form of guidelines for changes in driving style. Tips are presented on a small display, Figure 4.



Figure 4: Driving style tips display [6]

Criteria for evaluation of driving style are:

**Gear:** Does driver use the highest gear that traffic conditions permit

**Anticipation:** Does driver keep his distance from other vehicles so that he does not need to suddenly brake or accelerate

**Speed:** Is driver using the system that control speed (cruise ctrl.) on the open road

The 1<sup>st</sup> criteria suggests avoiding usage of an unnecessary power  $P=T\omega$ . When there is enough torque  $T$ , engine speed  $\omega$  reduction is achieved by shifting to higher transmission ratio, which makes the engine operate at lower speed resulting in decreasing number engine cycles for the same road length, saving fuel.

The 2<sup>nd</sup> criteria's aim is that vehicle maintains constant speed,  $v=const$ , as long as it's possible. Unnecessary braking drains kinetic energy and unnecessary acceleration requires additional kinetic energy.

The 3<sup>rd</sup> criteria is a trade-off for the 2<sup>nd</sup> ( $v=const$ ). The driver delegates vehicle motion control to the „Cruise Control“ system [7].

To sum up, the influential factors on fuel consumption are:

- Engine operation condition
- Vehicle acceleration way
- Vehicle mass magnitude

This paper defines the engine operation way and vehicle acceleration way in order to reduce fuel consumption. The influence of the mass on the dynamic characteristics of vehicle and ways to reduce masses are presented in the paper [2].

Following guidelines are adopted for control of engine operation during vehicle acceleration:

- Maximization of engine operation efficiency
- Optimization of vehicle acceleration performance
- Exclude drivers influence on engine operation

This paper presents active control of vehicle acceleration by numerical control of engine torque  $T$  using acceleration function that gives maximum efficiency of engine operation.

## 2. APPROACH TO PROBLEM

A speed characteristics of engine torque is defined by engine torque curve family. The „external“ characteristic curve determines torque values in relation to engine speed for maximum engine charge. The „internal“ characteristic curves corresponds to partial engine charge. Engine charge is determined by engine throttle angle  $\theta_i(h)$  which corresponds to accelerator pedal position  $h$ .

The lesser the engine charge is, the lower the maximum torque and engine speed, for family curve that corresponds to given engine charge. Also, the torque reaches its maximum value at lower engine speed.

The common characteristics curve connects points of maximum of particular family curves, Figure 5.

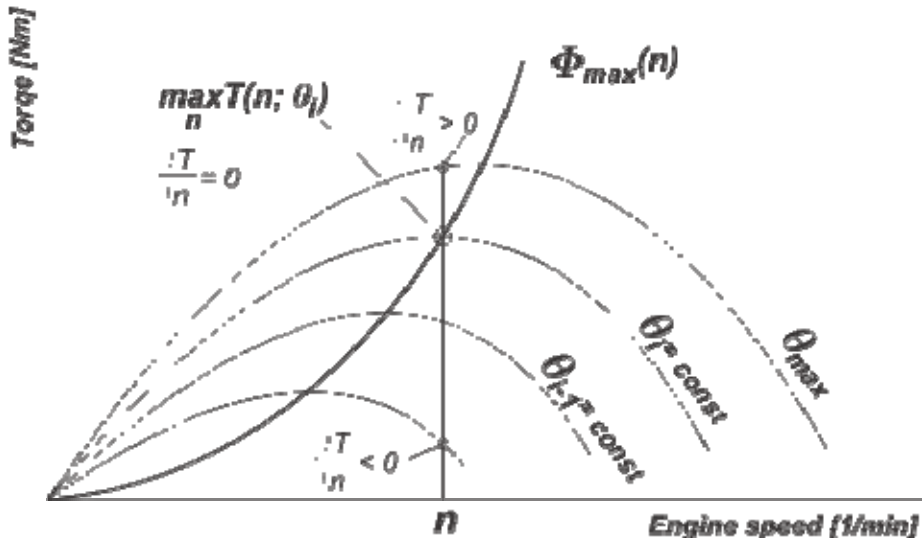

Figure 5: The common characteristic of torque curves family

The common characteristic of torque curves family is given by expression:

$$\Phi_{max}(n) = \left\{ T(n; \theta_i) \mid \theta_i : \frac{\partial T}{\partial n}(n; \theta_i) = 0 \right\}$$

Torque curves, for natural aspirated engine, have one maximum and inflection points.

## 2.1 ENGINE TORQUE EFFICIENCY DURING VEHICLE ACCELERATION

For any torque family curve member  $i$ , which corresponds to throttle angle  $\theta_i$ , the torque  $T(n; \theta_i)$ , depending on engine speed value, is lesser or equal to maximum value of that family member.

Acceleration of the vehicle is always conducted along one of the family curves. During acceleration, going from minimum to maximum engine speed value, the torque increases, reaches a maximum and then decreases. Engine torque efficiency  $\eta_T$  reaches its peak at the maximum torque. Before and after engine speed value  $n_i$  that corresponds to the maximum torque value, engine efficiency is lesser than its peak, as lesser torque is developed, Figure 6.

Maximum engine efficiency  $\eta_T = \max$  is realized when vehicle accelerates along the common characteristics  $\Phi_{max}(n)$  of torque family, because it passes through maximum torque values for particular engine charge.

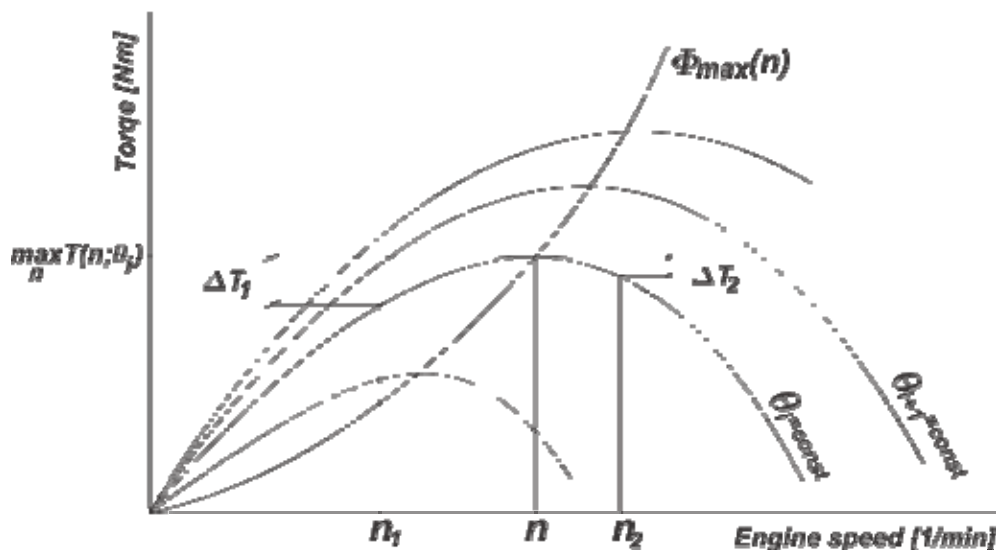

Figure 6: Engine torque efficiency

$$\max_n T(n; \theta_i) = T(n_2; \theta_i) + \Delta T_1 = T(n_2; \theta_i) + \Delta T_2$$

$$\eta_T = \frac{T(n; \theta_i)}{\max_n T(n; \theta_i)} \leq 1$$

Engine speed value  $n$  range in which the peak efficiency can be achieved, is defined by common characteristics curve domain:

$$n_{min} \leq n \leq n_T$$

$n_{min}$  – the lowest engine speed value required to move the vehicle

$n_T$  – engine speed value that corresponds to maximum torque for external characteristics

(For contemporary vehicles  $n_T \sim 3500$  [min<sup>-1</sup>].)

Vehicle acceleration controlled by driver is conducted by setting accelerator pedal position  $h$ . Once the accelerator pedal position is set, the driver, usually, does not change it during vehicle acceleration,  $h = \text{const}$ .

Vehicle acceleration along the common characteristic  $\Phi_{max}(n)$  requires continuous charge modification,  $\theta_i \neq \text{const}$ , because common characteristic consists of torque maximums for various engine charges. By operating accelerator pedal, the driver is unable to realize this relation  $h \rightarrow \theta_i \rightarrow \Phi_{max}(n)$ . To achieve engine charge that follows common characteristic curve, active control system for vehicle acceleration is needed.

For active vehicle acceleration, control is required via electronic system:

- Engine torque controller (hardware)
- Algorithm that accelerates vehicle (software)

Base information set for control are:

- Engine torque curve family,  $T(n; \theta_i)$  and

- Common characteristic curve,  $\varphi_{\max}(n)$

## 2. 2 VEHICLE ACCELERATION PERFORMANCE AND ENGINE TORQUE EFFICIENCY

Figure 7 shows comparison of torque values  $T$ ,  $T_e$ ,  $T_R$ , for fixed engine speed value  $n$ .

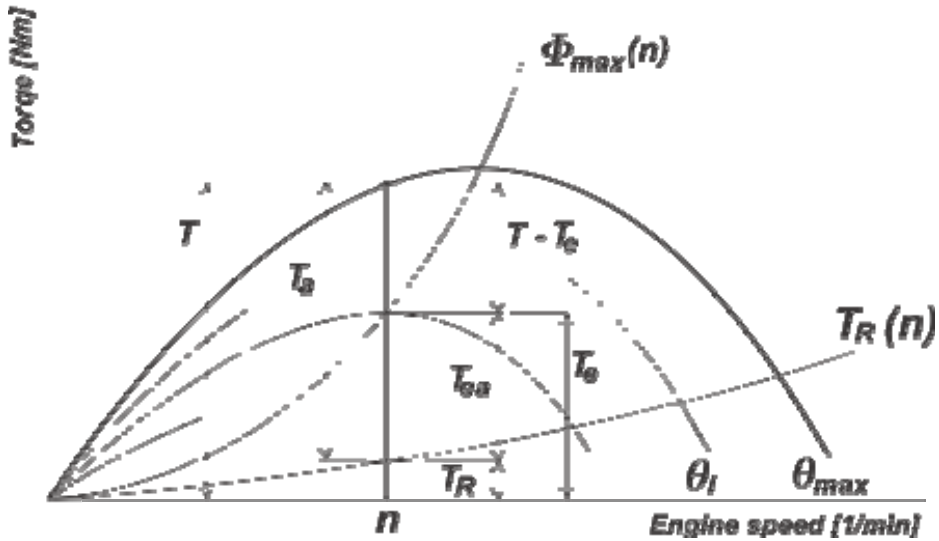

**Figure 7:** Comparison of engine torques along torque curve family with torques along acceleration function; Vehicle resistance torques

Values given in Figure 7 are:

- $T$  – torque value that corresponds to external characteristics
- $T_e$  – torque value that corresponds to common characteristics  $\varphi_{\max}(n)$
- $T_R$  – torque values of road resistance
- $T_e$  – torque on common characteristic for a particular charge
- $T_{ea}$  – torque available for vehicle acceleration

After overcoming road resistance torque  $T_R$ , remaining torque  $T_a$  for vehicle acceleration along external characteristics is

$$T_a = T - T_R$$

Remaining torque  $T_{ea}$  or vehicle acceleration along external characteristics is

$$T_{ea} = T_e - T_R$$

Torque difference  $\Delta T$  between torque  $T_a$  and torque  $T_{ea}$  for vehicle acceleration along common characteristics is

$$\Delta T = T - T_e$$

As engine speed  $n$  increases, that difference converges to zero:  $\Delta T \rightarrow 0$

In other words, with engine speed value  $n$  increase, vehicle acceleration performance along common characteristic  $\varphi_{\max}(n)$  continuously approach acceleration performance along external characteristic,  $T(n; \theta_{\max})$ :

$$\frac{T_f}{T} \rightarrow 1 = 100\%$$

The common characteristic is nonlinear increasing curve, and natural torque family curves have maximums. Increase of performance is greater at higher engine speeds, where it's necessary for them to be. (Natural reaction of driver who desires greater intensity of vehicle acceleration, is "stronger" accelerator pedal pressure resulting in driving with higher engine speeds).

Controlling vehicle acceleration along acceleration function achieves

- Increase in engine performance,
- vehicle acceleration control without driver.

### 3. DEFINING ENGINE TORQUE CURVE FAMILY

Engine torque curve family is defined by

$$T = T(n; \theta_i)$$

Acceleration function curve  $\varphi_{\max}(n)$  intersects torque curve family  $T(n; \theta_i)$ .

#### 3.3 OBTAINING CURVE FAMILY

For vehicle, only external torque and power curve is available in the form of smooth curves ("polished" version). The curve families with partial charges are unavailable even for the stationary state. The family of curves during vehicle acceleration (unsteady state, "transients") are unavailable. Determination them is complicated and expensive, and vehicle performance during acceleration is reduced: Part of engine torque is spent on accelerating translationing and rotating masses, [8,9], and the engine speed changes, resulting in less efficient combustion cycles.

There are test benches for determining speed characteristics with software that simulate influence of mass on vehicle acceleration [10]. In the end, actual performance must be determined while the vehicle is on the road.

In this study, for determining engine torque curves family during vehicle acceleration, the physical - mathematical model for wheel torque  $T_f$  for vehicles with front wheel drive. Through the transmission ratio  $i$ , wheel torque is reduced to engine torque  $T$ . Throttle angle  $\theta_i$  for family members is controlled via electronic accelerator pedal signal (ETC).



### 3.2.1 Physical – mathematical vehicle acceleration model

Figure 8 shows the vehicle (one longitudinal half of it, "bicycle"), which speeds up along a straight line. Front wheel is driving one, rear wheel is non-driving.

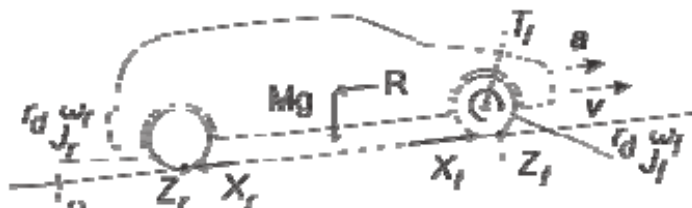

Figure 8: Forces acting on vehicle during accelerating motion

Marks in Figure 8 are:

- $T_f$  – driving wheel torque
- $X_f$  – horizontal road resistance to front wheel (driving wheel tangent reaction)
- $X_r$  – horizontal road resistance to rear wheel (non-driving wheel tangent reaction)
- $Z_f, Z_r$  – vertical road reaction to front and to rear wheel
- $R$  – vehicle movement resistances
- $v$  – vehicle speed
- $a$  – vehicle acceleration
- $\dot{\omega}_f, \dot{\omega}_r$  – angular acceleration of front and rear wheel
- $M=1/2m$  – longitudinal half vehicle mass,  $m$  – vehicle mass
- $g$  – gravitational acceleration
- $J_f$  – moment of inertia of one front wheel, and half of drivetrain, clutch and crankshaft
- $J_r$  – moment of inertia of one rear wheel
- $r_d$  – dynamic wheel radius
- $\alpha$  – climbing angle

(All basic and derived measurement units of physical quantities and their designation are SI)

Recording  $T(n)$  engine torque family curves is performed on a horizontal road:  
 $\alpha=0 \rightarrow \sin\alpha=0, \cos\alpha=1$

Torque balance of front and rear wheel are given in equations (1) i (2):

$$T_f - X_f r_d = J_f \dot{\omega}_f \quad (1)$$

$$X_r r_d = J_r \dot{\omega}_r \quad (2)$$

Angular acceleration values  $\dot{\omega}_f, \dot{\omega}_r$  of front and rear wheel are known, due to measuring angular speeds  $\omega_f$  i  $\omega_r$  during time  $t$ .

Adding equation (1) to (2), the torque balance of front and rear wheel is obtained

$$T_f - (X_f - X_r)r_2 = J_f\dot{\omega}_f + J_r\dot{\omega}_r \quad (3)$$

In equation (3) tangent reaction difference  $X_f - X_r$  is unknown because tangential reactions itself are unknown. In order to eliminate tangent reactions  $X_f$  and  $X_r$  horizontal forces balance equatoions (4) is:

$$Ma = X_f - X_r - R \quad (4)$$

Unknown vehicle acceleration  $a$  is determined by angular acceleration  $\dot{\omega}_r$  of rear wheel:

$$a = r_2 \dot{\omega}_r \quad (5)$$

Substituting acceleration  $a$  from expression (5) into equation (4) eliminates the unknown acceleration  $a$  from (4) and gives:

$$Mr_2\dot{\omega}_r = X_f - X_r - R \quad (6)$$

Evaluating (6) tangent reaction difference  $X_f - X_r$  is obtained as:

$$X_f - X_r = Mr_2\dot{\omega}_r + R \quad (7)$$

Substituting (7) into (3) torque equation (8) is obtained, in which front wheel torque  $T_f$  and vehicle motion resistance  $R$  are unknown values:

$$T_f - (Mr_2\dot{\omega}_r + R)r_2 = J_f\dot{\omega}_f + J_r\dot{\omega}_r \quad (8)$$

Although front and rear wheel angular velocities are known (they are measured), to simplify equation (8) assumption (9) are introduced:

$$\omega_f = \omega_r \xrightarrow{\text{yields}} \dot{\omega}_f = \dot{\omega}_r \quad (9)$$

When introducing connections (9) a small error is made: The front wheel rotates at higher speed than the rear one, because the twisting and sliding of drive wheel tire is greater due to front wheel driving torque  $T_f$ . In addition, the drive wheel and non-wheel drive sliding is in opposite direction.

However, experiments have shown that the error that appears made by assumption (9) is without affecting the result.

Using assumption (9) torque equation (10) is obtained:

$$T_f - (Mr_d \dot{\omega}_f + R)r_d = (J_f + J_r)\dot{\omega}_f \quad (10)$$

According to [6,7] the inertia moments  $J_f, J_r$ , can be replaced with

$$I = J_f + J_r = \frac{1}{2} (1 + \delta_1 i_g^2 + \delta_2) [kg \cdot m^2]$$

$\delta_1$  – influence ratio of engine and clutch rotating masses

$\delta_2$  – influence ratio of drivetrain rotating masses

$i_g$  – gear selected for vehicle motion

By solving equation (10):

$$T_f - R \cdot r_d = (Mr_d^2 + I)\dot{\omega}_f \quad (11)$$

In equation (11) is  $R \cdot r_d$  torque resistance  $T_{fR}$  to vehicle motion:

$$T_{fR} = R r_d \quad (12)$$

By introducing (12) into (11) gives:

Torque equation for vehicle driving wheel

$$T_f - T_{fR} = (Mr_d^2 + I)\dot{\omega}_f \quad (13)$$

To transform torque from vehicle wheel to engine, torque (14) and angular velocity relations (15) are introduced:

$$T = \frac{T_f}{i}, T_R = \frac{T_{fR}}{i} \quad (14)$$

$$\omega_f = \frac{\omega}{i} \xrightarrow{\text{yields}} \dot{\omega}_f = \frac{\dot{\omega}}{i} \quad (15)$$

$i$  – total transmission gear ratio [-]

With introduction of relations (14) and (15) into (13):

$$i(T - T_R) = (Mr_d^2 + I)\dot{\omega} \quad (16)$$

Relation between circular frequency of angular velocity [rad] and engine speed [o/s] is

$$\omega = 2\pi n \xrightarrow{\text{yields}} \dot{\omega} = 2\pi \dot{n} = 2\pi \frac{dn}{dt}, \quad n \left[ \frac{o}{s} \right] \quad (17)$$

With introduction of relation (17) into (16) gives:

Rate of change  $dn/dt$  of engine speed  $n$  during vehicle acceleration

$$\frac{dn}{dt} = \frac{e}{2\pi(nr_d^2 + j)} (T - T_R) \quad (18)$$

- $T$  – engine torque
- $T_R$  – torque resistance to vehicle motion, transformed to engine
- $T - T_R$  : torque difference between engine torque and resistance torque, that remains for vehicle acceleration  $a$

Engine speed  $n$  during vehicle acceleration is measured by engine speed sensor and rate of change  $dn/dt$  is calculated (which is explained in paragraph 4.2)

From equation (18) by calculation follows:

Engine torque  $T$  for vehicle acceleration

$$T = \frac{2\pi(nr_d^2 + j) \frac{dn}{dt}}{e} + T_R \quad (19)$$

Engine torque  $T_R = T_{fR}/i$  due to vehicle motion resistance at constant velocity  $v = \text{const}$ , when influence of inertia is not present,  $dv/dt = 0$ , is related to external environment. It occurs on the path – road that vehicle passes. It consists of air drag torque  $T_{drag}$ , rolling resistance torque  $T_{roll}$  and climbing resistance torque  $T_{climb}$  [8,9]:

$$T_{fR} = T_{drag} + T_{roll} + T_{climb} \quad (20)$$

- $T_{fR} = R \cdot r_d$  – torque resistance to motion
- $R$  – resistance to vehicle motion
- $r_d$  – dynamic wheel radius

Total motion resistances  $R$  are given by expression (21), [8,9]:

$$R = R_{drag} + R_{roll} + R_{climb} \quad (21)$$

where particular resistance is given as

- $R_{drag} = KAv^2$  – aerodynamic resistance force [N]
- $R_{roll} = Gf_{roll} \cos \alpha$  – rolling friction resistance [N]
- $f_{roll}$  – Coefficient of rolling resistance [-]
- $R_{climb} = G \sin \alpha$  – grade resistance [N]

Using particular resistance expressions, equation (21) turns to

$$R = KAv^2 + Gf_{roll} \cos \alpha + G \sin \alpha \quad (22)$$

#### 4. EXPERIMENTAL RESULTS

Experimental research has been done using vehicle *VW Polo 1.2* engine with computer *SIMOS N9.1*. The vehicle is shown in Figure 9.



*Figure 9: Experimental vehicle*

#### 4.4 VEHICLE AND TRANSMISSION PARAMETERS (VEHICLE SETUP)

Following data are obtained from reference [9] or arbitrarily chosen according to guidelines presented in reference [9].

##### **Vehicle**

- $K=C_x \cdot \rho / 2$  – reduced air drag resistance coefficient [kg/m<sup>3</sup>]; [7]
- $C_x$  – aerodynamic drag coefficient = 0.30 [-]
- $\rho$  – mass density of air = 1.226 [kg/m<sup>3</sup>]; [7]
- $A$  – frontal area of the vehicle = 1.75 [m<sup>2</sup>]
- $G=2Mg$  – vehicle weight [kN],  $M$  – mass [kg] longitudinal vehicle half
- $2M=1200$  [kg]
- $g=9.81$  [m/s<sup>2</sup>] acceleration due to gravity
- $r_d=0.3$  [m] dynamic wheel radius

##### **Drivetrain**

- $i = i_0 i_l = 16.01$  [-] – overall transmission ratio
- ( $i_0$  – main drive transmission ratio [-])
- ( $i_l$  – first gear transmission ratio [-])

$J=1/2\delta=1/2(1+\delta_1(i_g)^2+\delta_2)$  [kgm<sup>2</sup>], moment of inertia due to [9]  
 $\delta_1 = 0.020$ [kgm<sup>2</sup>] influence ratio of engine and clutch rotating masses, adopted according to [9]  
 $\delta_2 = 0.025$ [kgm<sup>2</sup>] influence ratio of drivetrain and wheels rotating masses, adopted according to [9]

Total gear ratio is obtained by calculating the ratio of engine to front wheel revolutions:

$$i = \frac{n}{n_f} = \frac{\omega_f}{\omega_f} = \frac{\omega_f}{\frac{v}{r_g}} = \frac{v}{r_g} \left[ \frac{\text{rad}}{\text{s}} \right]$$

Vehicle speed is measured during constant vehicle speed,  $v=const$ , using satellite navigation device (GPS), and respective number  $n$  of engine speed, taken from crankshaft.

For the vehicle speed of  $v=25$  [km/h] and its respective engine speed of  $n=3545$  [1/min] the overall first gear transmission ratio is calculated to  $i=16.04[-]$ . The transmission ratio was calculated several times for various sets of values for engine speed and vehicle speed, yielding similar results.

Overall transmission ratio depends on gearbox transmission ratio, which is fixed as design characteristic, and dynamic wheel radius which varies on tire type, size, pressure and wear, as well as vehicle mass distribution on individual wheel. More mass on wheel results in smaller dynamic radius. In order to include all of this influences on dynamic wheel characteristic, overall transmission ratio was calculated using engine speed and vehicle speed and not by simply using technical data for vehicle transmission provided with the vehicle.

#### 4. 5 RECORDING AND PROCESSING DATA FOR TORQUE CURVE ENGINE FAMILY

Torque curve family has been created from records of particular family members that relate to their throttle angle  $\theta_i$ , with assistance of custom ETC software via microcontroller. The family was recorded for both 1st and 2nd gear, in order to minimize computational errors.

Vehicle accelerated in range  $(n_{min}, n_{max})$  for each engine charge set by throttle angle.

Signals of engine speed  $n$  were recorded during time  $t$  and its rate  $dn/dt$  was calculated according to expression logic (18). Signals were taken from engine speed sensor.

Signal processing yields engine speed  $n$  and it's rate of change  $dn/dt$ .  $T_R$  corresponds to external resistances and is calculated from  $n$  and overall transmission ratio as explained below expression (19). Finally, torque  $T$  (speed characteristic of engine) is calculated according to expression (19). Note that, according to (18),  $dn/dt$  depends on external resistances so they are unavoidably included in the evaluation of  $dn/dt$  from measurements.

To process and to transform signal data  $n/t \rightarrow dn/dt \rightarrow T(n)$  special software was developed from scratch.

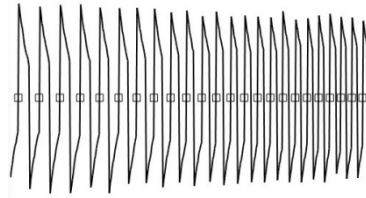

**Figure 10a:** Raw data of recorded signal

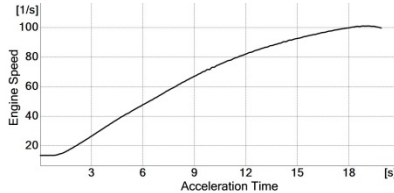

**Figure 10b:** Engine speed vs time

The algorithm use statistical analysis to identify signal periods from raw data shown in Figure 10a. Small squares displayed in Figure 10a, are not part of signal raw data and they show the result of identification. The program adds this squares automatically. Then, lengths of periods and their time indexes are calculated and transforming into engine speed in time, as shown in Figure 10b. Having the functional dependences of engine speed to time, program then calculates the rate of change of engine speed in time, which is used in expression (19) to calculate torque.

Figure 11 shows torque speed characteristic  $T(n)$  obtained by described procedure.

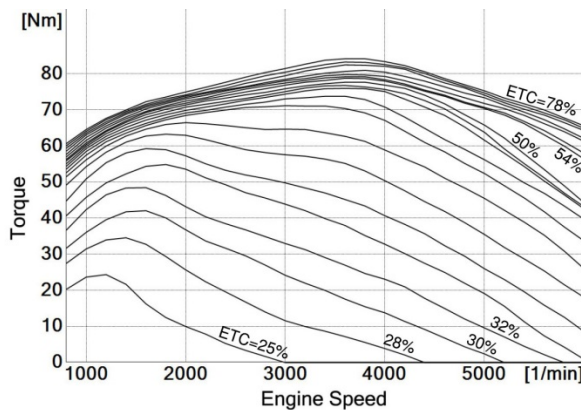

**Figure 11:** Engine torque family curves

In Figure 11, torque family parameter is the ETC position wich uses values: {78, 74, 70, 66, 62, 58, 54, 50, 48, 46, 44, 42, 40, 38, 36, 34, 32, 30, 28, 25}. ETC positions over 78% do not significantly increase engine torque.

Torque curve maximums for low and middle values  $T < 65$  [Nm] are found at lower engine speeds  $n < 2000$  [o/min]. Torque curve maximums for values  $T > 70$  [Nm] and further toward external characteristic are located in range of revolutions  $n = (3500 \div 4000)$  [o/min]. In addition, for torque values  $T > 50$  [Nm] there is an accumulation of curves, despite to equal increment step of ETC position of 4%.

Appearance of curves family is a consequence of engine computer remapping.

For lesser engine charges, torque maximums are shifted toward lower revolutions. Shifting suitable operating mode at lower charges to lower engine speed, stimulates the ride at lower revolutions. Higher gear ratios are implicated. It is a matter of fuel consumption optimization and extending engine working life time.

For grater charges maximal performances have to be allowed. However, such a driving is discouraging: The same increase of ETC position in maximal torques domain yields far less torque than the increase in medium and low engine torques (charges). This behavior is achieved due to family curves accumulation in the area of large torques (charges).

(Remapping is introduced from vehicle manufacturer).

After signal data processing and transformation, torque family data are obtained, whose analog form is showed in Figure 11, and its digital form is saved into lookup table.

Common torque family characteristic from Figure 11 is shown in Figure 12.

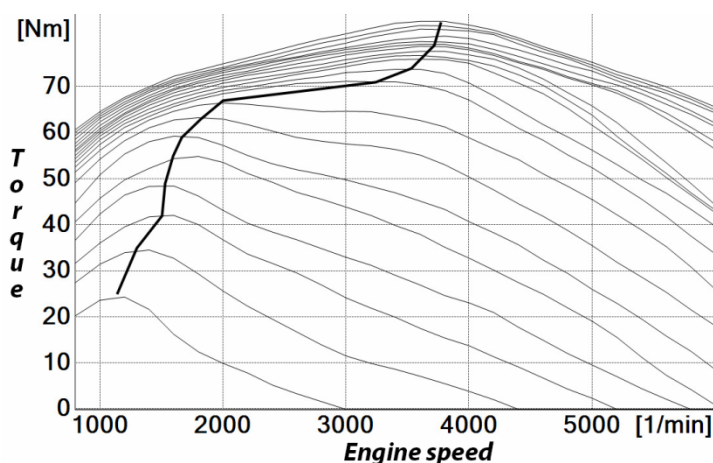

*Figure 12: Common torque curve characteristic of experimental vehicle*

#### **4. 6 ENGINE CHARGE CONTROLLER AND PROGRAMMING CODE FOR VEHICLE ACCELERATION**

In order to control vehicle acceleration new controller (hardware) is developed from scratch. The controller is shown in Figure 13.

Controller intercepts signals of electronic throttle control (ETC) and sends signals to engine control unit (ECU) through which it controls engine charge along acceleration function. The only driver's task is to give starting charge by pressing accelerator pedal.

Engine charge control is conducted by controlling throttle [11], and setting its angle  $\theta$ . Commonly a feedback loop [12] is used (i.e. PI regulation).

Lack of feedback loop control regulation is angle oscillations,  $\pm\Delta\theta$  of throttle valve flap, which occurs around controlled angle  $\theta_i$ , due to error compensation during engine torque regulation [13]. Throttle flap oscillations cause unsteady state of engine charge, therefore fuel consumption rises and exhaust gas composition especially gets worse.



In solution shown in this study throttle valve flap oscillations do not exist.

Controller work information is current engine speed. As revolutions increase in small steps (increment) flap grows, too. Change is smooth and only in the direction of angle increase.

There are two more acceleration functions for which the controller can perform vehicle acceleration: One prevents excessive torque that causes drive wheels to spin on the slippery road, and the other increases passenger comfort changing acceleration characteristic and controlling its intensity. Showing of results obtained with these features is a topic for another paper.



**Figure 13a:** Torque controller

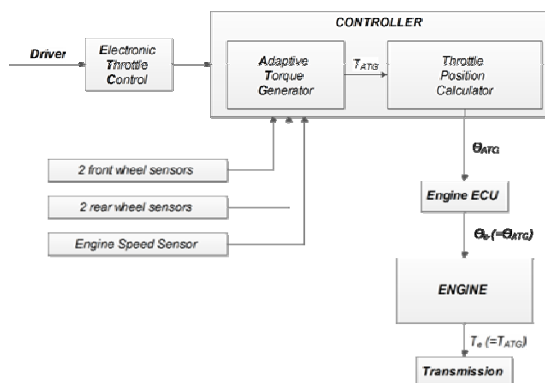

**Figure 13b:** Block diagram of Torque controller

Figure 13b, Block diagram, explanation:

- *Driver*: Sets desired *ETC* position
- *ETC*: Transmits signal to *Controller*
- *Controller*: Determines engine torque  $T_{ATG}$  and its corresponding throttle valve angle  $\square_{ATG}$  and sends it to *Engine ECU*
- *Engine ECU*: Sets throttle valve angle  $\square_e$  to calculated value  $\square_{ATG}$
- *Engine*: Produces engine torque  $T_e$  which value is  $T_{ATG}$  and delivers it to the *Transmission*
- *Feedback*: Current engine speed is sent back to *ATG Controller*

Figure 13b shows control flow diagram of vehicle acceleration. During acceleration, the driver sets desired engine torque using accelerator pedal, ETC. Controller successively modifies signals sent to ETC according to maximal engine torque efficiency acceleration function  $\varphi_{\max}(n)$  and relays them to engine computer, ECU. Engine computer gradually opens throttle valve, engine torque increases and vehicle accelerates. Current engine speed is feeded into controller and it is used for successive increase of throttle valve angle in real-time. Controlled acceleration ends when the engine reaches torque desired by driver. Wheel speed sensors shown in Figure 13b are used in case the vehicle starts to skid (mostly on slippery road) in conjunction with another acceleration function to prevent transmission of excessive engine torque to wheels.

#### 4. 7 NUMERICAL CONTROL OF VEHICLE ACCELERATION

For controller operation, two new programs are developed from scratch, one to control and one to execute (software).

**Control code** includes Control functions for acceleration (logic), and is written in the programming language C Sharp (C #). Control code passes data to executive code.

**Executive code** includes Executive instructions for acceleration (execution), and is written in the programming language C. The code passes data to engine control unit (ECU) for throttle valve angle flap.

Two codes are connected through external link for data communication.

Numerical acceleration control by programming code accelerates vehicle along acceleration function in such a way that torque  $T_e$  values correspond to maximal torques of partial engine charges  $\theta$ :

$$T_e = \varphi_{\max}(n)$$

$T_e$  – engine torque on common characteristic curve

$n$  – engine speed, acceleration function parameter

Note that acceleration function calculates torque for common characteristic curve from engine speed.

**First step** is finding torque  $T_e$ , on common characteristic family curve for actual number  $n$  of revolutions:

$$n, \varphi_{\max} \xrightarrow{\text{lookup}} T_e$$

**Second step** is finding throttle valve flap angle  $\theta$  for actual number  $n$  of revolutions and torque  $T_e$  on common characteristic family curve:

$$n, T_e \xrightarrow{\text{lookup}} \theta$$

Valve flap angle  $\theta$  determines member  $\theta_i$  of torque family that intersects common characteristic family curve at engine speed  $n$ .

Torque family is digitalized and stored in lookup table.

Calculation procedure is repeated as number  $n$  of revolutions increments in time  $t$ .

#### 4. 8 EXPERIMENTS WITH VEHICLE ACCELERATION BY ACCELERATION FUNCTION

When the driver presses accelerator pedal, controller takes control over engine charge. Development of torque does not go beyond its natural curve  $T(n;\theta_i)$ , instead it follows curve  $\varphi_{\max}(n)$  of acceleration function:

$$T = \begin{cases} \varphi_{\max}(n), & T(n, \theta_i) > \varphi_{\max}(n) \\ T(n, \theta_i), & T(n, \theta_i) \leq \varphi_{\max}(n) \end{cases}$$

Vehicle acceleration along acceleration function ends in the intersection point of natural engine curve  $T(n;\theta_i)$ , and acceleration function curve  $T$ . Engine charge for natural curve is determined by throttle valve flap angle  $\theta_i(h)$  – for selected position  $h$  of accelerator pedal.

Figure 14 shows vehicle acceleration curve along acceleration function  $\varphi_{\max}(n)$  of maximal engine effectiveness for external torque characteristic,  $\theta_{\max}(h_{\max})$ . The curve is recorded while driving in 2nd gear, i2. Oscillatory appearance of curve is result of noise in the signal. In reality there are no flap oscillations, because changes of throttle valve angle are incremental and with small step.

By remapping engine control unit (ECU) the nature of torque family has been changed, so that instead of just one maximum, curves have two local maximums near to torque value  $T(n=2500)=60$  [Nm]. Therefore the program that controls acceleration does not function with the expression given nearby Figure 6, where throttle valve flap angle  $\theta_i$  for maximum torque curve determines partial function derivate to number  $n$  of revolutions:

$$\theta_i: \frac{\partial T}{\partial n}(n; \theta_i)$$

Instead, program functions with the expression:

$$\phi_{max}(n) = \left\{ T(n; \theta_i) \mid \theta_i: T(n; \theta_i) = \max_n T(n; \theta_i) \right\}$$

According to the previous expression flap angle  $\theta_i$  is such that for fixed value  $n$  the corresponding torque curve value is exact as its maximum value on the whole engine speed range.

$$\theta_i: T(n; \theta_i) = \max_n T(n; \theta_i)$$

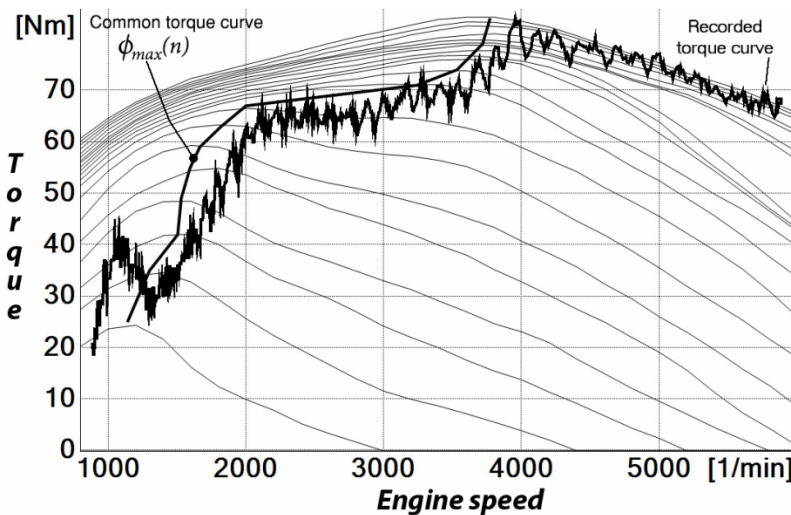

Figure 14: Torque curve recorded during vehicle acceleration vs Common torque curve characteristic

The common torque curve is used as an acceleration function and recorded torque curve in Figure 14 is real acceleration curve which is a result of controlled acceleration using acceleration function.

The recorded acceleration curve, shown at Figure 14, is obtained exactly as the torque curve family were obtained using expression (19) and signal processing.

#### 4.5.1 Flow of acceleration curve

Vehicle was accelerating longitudinally, i.e. along straight line on horizontal road in 2nd gear from  $n=n_{min}\sim 800$  [1/min] to  $n_{max}=6000$  [1/min]. Engine has electronically limited maximum speed of  $n=n_{max}$ . At engine speed  $n=6000$  [1/min] vehicle reaches the speed of  $v=90$  [km/h].

At the beginning vehicle is moving at a constant minimum speed,  $v=const$ ,  $n_{min}=const$ , and accelerator pedal is set to default position  $h=h_{min}$  (not pressed). Recording starts the moment the accelerator pedal has been suddenly pressed to its maximal position  $h=h_{max}$ . Engine speed rises from  $n\sim 800$  [o/min] to  $n\sim 1100$  [1/min] followed by torque rise to a value of  $T\sim 40$  [Nm]. During that time controller makes calculations for values of  $n$  and  $\theta_i$  for the beginning of acceleration.

In the range  $n\sim(1100$  [1/min] $\div$  $1350$  [1/min]) controller reduces charge (engine load) and engine torque decreases to minimal value of  $T\sim 27$  [Nm]. From that point engine starts to follow acceleration function  $\varphi_{max}(n)$ .

From  $n\sim 1350$  [1/min] to  $n\sim 3700$  [1/min] the controller follows common characteristic curve.

At  $n\sim 3770$  [1/min] controller leaves acceleration function  $\varphi_{max}(n)$  and engine reaches external speed characteristic of torque curve whose  $T_{max}\sim 80$  [Nm].

Up from  $n\sim 4000$  [1/min] ends control and further vehicle acceleration is taking place on the natural curve torque  $T(n;\theta_{max})$ . Throttle valve flap angle reaches  $\theta_i=\theta_{max}$ , control of accelerator pedal signals stops and pedal control is returned to driver, who keeps accelerator pedal pressed down to the floor, all the time. (However, safety measures make it possible that control of vehicle motion to be returned to the driver immediately at any moment).

Record of acceleration curve shows that controller optimizes torque rise in range  $n=(1600\div 2000)$  [1/min], deviating minimally from common characteristic curve and also at  $n=3770$  [1/min]. Following strictly common characteristic would demand rapid changes of  $\alpha=da/dt$  and  $a$  acceleration, which is undesirable, because it will result in increase in fuel consumption and worse composition of exhaust gases.

#### 4.9 ENERGY CONSUMPTION

Otto engine uses mixture of fuel and air whose ratio varies within very small range. In homogenous engine operation, for experimental vehicle, so called "ideal mixture" is used which has excess air coefficient  $\lambda=1$  [-]. Fuel is injected into the intake pipes, while the exhaust system has a three way catalytic converter for exhaust gases neutralization only (no converters for nitrogen oxides, which is typical for operation with poor mixture,  $\lambda<1.05$ ). Also, the engine does not have a valve for exhaust gas recirculation, EGR.

Mixture composition where  $\lambda=1$  is stoichiometric, where for combusting  $1$  [kg] of fuel,  $14.7$  [kg] of air is used.

During acceleration ECU may enrich the mixture by  $1-3\%$  ( $\lambda=0.97-1.00$ ) which deviates from "ideal mixture" in order to speed up fuel combustion. Mixture enrichment depends on acceleration intensity. The greater the acceleration, the richer the mixture is.

Acceleration intensity during uncontrolled acceleration is greater than during controlled acceleration, where the fuel consumption is lower on basis of mixture composition. Therefore, the fuel consumption can be taken as proportional to air mass flow under assumption that mixture composition is the same during both controlled and uncontrolled acceleration,  $\lambda_c=\lambda_u$ .

The air mass consumption was measured in time using hot film air mass meter “HFM5”, [12], Figure 15b. Data were taken during acceleration ( $2^{nd}$  gear, overall transmission ratio  $i=8.68$ ) where engine speed ranges from  $n=850$  [1/min] to  $n=5500$  [1/min]. For comparing consumed air masses, engine speed range from  $n=1140$  [1/min] to  $n=3770$  [1/min] is selected, since maximal engine torque efficiency acceleration function is defined in that range. For both controlled and uncontrolled acceleration, accelerator pedal ETC was pressed rapidly to its maximal position and held down during the whole acceleration.

Data from sensor was captured using two-channel oscilloscope “PICO” for car engines and recorded to a “csv” file, which computer program uses as an input for processing.

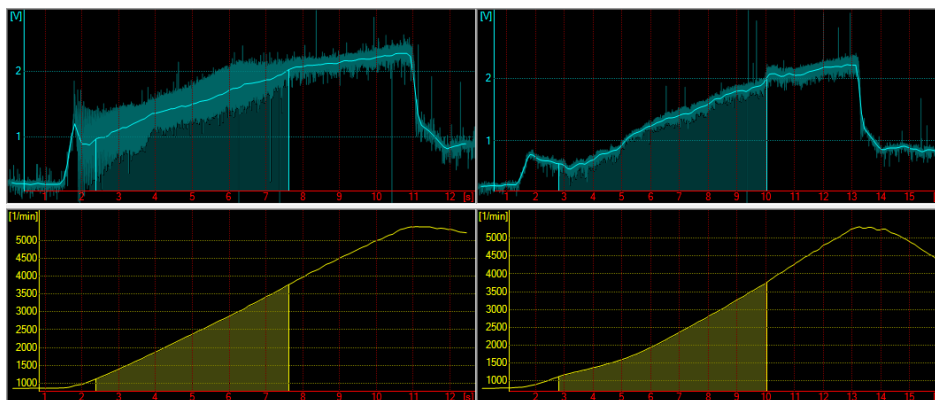

**Figure 15a:** Air mass meter and intake hose installation setup



**Figure 15b:** Air mass meter closeup

To reduce disturbance as much as possible, a long intake hose (white) is installed as shown in Figure 15a. Air enters air mass meter first, then flows through the hose toward throttle valve. Hose length and hose bends reduce energy of disturbance travelling to measurement device.



**Figure 16:** Air flow data (top) and engine speed (bottom) in time during uncontrolled (left) and controlled (right) acceleration

Top images in Figure 16 show graphical representation of data taken from air mass meter as voltage in time. The bright smooth curve is a result of processing the raw data numerically in order to eliminate noise. The noise in raw data is a result of disturbance in

the air flow induced while opening and closing the intake valve. This noise is greater during uncontrolled acceleration because the throttle valve is wide open (WOT). During controlled acceleration, throttle valve is less open and it acts as a barrier for the air flow wavefronts, resulting in significantly less disturbance.

From 1.5s to 2.0s, the air flow curve has a characteristic rise as a consequence of sudden opening of the throttle valve. The air rapidly fills the intake pipe behind the throttle valve toward intake valves, where afterwards engine starts air suction, causing the air flow curve to decline. After that, the air flow curve is continuously rising as the engine speed is increasing.

Total air mass  $m$  consumed and distance travelled  $S$  during both controlled and uncontrolled acceleration are:

$$m = A \cdot k, \quad A = \int_{t_1}^{t_2} U(t) dt$$

$$S = N \cdot i, \quad N = \int_{t_1}^{t_2} n(t) dt$$

- $U(t)$  – air mass flow curve (obtained by processing air flow data) [V]
- $t_1, t_2$  – time indexes at which the engine speed is at 1140[1/min] and 3770[1/min]
- $A$  – area below  $U(t)$  from  $t_1$  to  $t_2$  (shaded area in Figure 16, top sections) [Vs]
- $k$  – constant of ratio between mass  $m$  and  $A$  [kg/Vs]
- $m$  – total mass of air flown through the air mass meter [kg]
- $n(t)$  – engine speed in time (curves in bottom sections of Figure 16) [1/min]
- $N$  – area below  $n(t)$  which is total number of engine revolutions between  $t_1$  and  $t_2$  [-]
- $i$  – overall transmission ratio [-]
- $S$  – total distance travelled [m]

The effect of controlled acceleration on energy saving  $E$  is obtained by calculating ratio between average air mass flows over their respective distances,  $m_c/S_c$  for controlled and  $m_u/S_u$  for uncontrolled:

$$E = \frac{\frac{m_c}{S_c}}{\frac{m_u}{S_u}} = \frac{\frac{A_c \cdot k}{N_c \cdot i}}{\frac{A_u \cdot k}{N_u \cdot i}} = \frac{\frac{A_c}{N_c}}{\frac{A_u}{N_u}} = \frac{I_c}{I_u} [-], [%]$$

$I_c, I_u$  – indicators of air (fuel) consumption reduced to travelled distance for controlled,  $c$ , and uncontrolled,  $u$ , acceleration [Vs]

Note that calculation of  $E$  is independent of selection of constants  $k$  and  $i$  to be known.

#### 4.6.1 Experimental results

Several sets of data was collected, compiled and ordered into a table below.

**Table 1:** *Experimental data with effectiveness calculations*

	$t_0$ [s]	$t_1$ [s]	$\Delta t$ [s]	$A$ [Vs]	$N$ [-]	$I=A/N$ [Vs]
<b>Controlled</b>	2.805	10.019	7.214	9.133037	264.87	0.034481
<b>Uncontrolled</b>	3.057	7.601	4.544	7.184566	190.01	0.037812
<b>Ratio</b>	-	-	<b>159%</b>	<b>127%</b>	<b>130%</b>	<b><math>E = 91%</math></b>

Note: Values  $A$  and  $N$  are computer calculated

Table 1 shows that duration  $\Delta t$  of controlled acceleration is 59% greater than duration of uncontrolled acceleration and that is due to lower engine torque during controlled acceleration. Area  $A$ , which reflect total air masses consumed, is 27% greater during controlled acceleration, while the total number of engine revolutions  $N$ , which reflect travelled distance, is 30% greater during controlled acceleration.

Indicators  $I=A/N$  of air (fuel) consumption show that  $I_c < I_u$  ( $0.034481 < 0.037812$ ), which means that controlled acceleration consumes less fuel than uncontrolled one.

Effectiveness  $E=I_c/I_u=91%$  shows that 9% of the fuel is saved during controlled acceleration for the same starting and ending engine speed, thus the same starting and ending vehicle speed.

## 5. CONCLUSIONS

Researchers make continuous efforts to improve vehicle fuel economy and reduce their impact on the environment. Measures for reducing fuel consumption are transferred to the control of movement, and in particular to control vehicle acceleration. Vehicle acceleration takes up to 40% of total fuel consumption. Significant fuel savings, >25% are made just with smooth drive, by constant speed,  $v=const$ .

However, the vehicle is inevitably moving with variable speed. Changing vehicle speed means vehicle acceleration,  $a=dv/dt$ , and transition to acceleration movement changes the way of acceleration,  $\square=da/dt=d^2v/dt^2$ .

The usual reduction in fuel consumption is achieved by the formula:

*"Reduction of torque + delay in responding to pedal pressure."*

Acceleration  $a$  is controlled by reducing torque. The "Torque map" is reprogrammed on relation *accelerator pedal movement – number of revolutions – engine torque*. Frequently for original mode of operation two different modes are added, resulting in a three-level control with the exclusive choice.

By reducing torque vehicle performance are reduced.

Delayed response of the throttle controls acceleration change  $\square$  of acceleration  $a$ . The delay in the response of accelerator pedal is realized by software modification of electronic throttle control (ETC) signals.

Slow response to the accelerator pedal pressure reduces car driveability.

This paper presents study results of vehicle acceleration control by numerical engine torque control in function of acceleration.

Inevitable formula of torque reduction and throttle response delay for acceleration control  $a$  and acceleration rate  $\square$  is applied. However, the approach is different: Maximum engine torque efficiency used at relation *accelerator pedal movement – number of revolutions – engine torque*.



With this approach, the loss of the vehicle's performance is minimal. Regulation of torque impairment is single stage, continuous and progressive: Vehicle performance and responsiveness to accelerator pedal position change increase as engine speed increases.

Torque family is the starting information used to control engine torque.

To supply a torque family in transitional period special physical - mathematical model is developed. Based on the model, individual family members are captured during vehicle acceleration on the road. This takes two important influential factors into account:

- Reducing vehicle performance due to reduced engine torque caused by inertia resistance
- Engine effectiveness decrease due to of variable engine working speed

Using the common torque characteristic curve, which passes through torque maximums of family members, a function along which guided engine torque during vehicle acceleration is created. Natural engine torque curve is replaced by a curve with a maximum torque effectiveness. This increases the effectiveness of vehicle acceleration.

To control the acceleration, controller (hardware) and program (software) are designed. Programming code reads data from torque family table. The table stores digital data on the size of the torque, depending on engine speed for the family members. Each member of the torque family represents engine charge determined by throttle valve flap angle.

The program calculates the required torque magnitude for acceleration function and current engine speed. For calculation numerical methods are used, interpolation and advanced programming techniques. The results of the program calculation are passed to controller, which via executable code controls throttle valve in order to charge engine.

By given solution at lower speeds fuel savings are greater, but performances are inevitably reduced. Inverse is also true: With speed increase fuel savings decreases, but performances rise.

Here presented system interacts with driver. The driver determines the starting and ending engine speed by increasing position of accelerator pedal. Choosing the engine speed range for acceleration of the vehicle driver affects vehicle performance and fuel economy. Higher engine speed ranges provide better performance at the higher cost.

Idea of the concept is preliminary tested on the computer, before the concept is tested in practice. For this purpose a special simulation software is developed.

Experimental results show that energy consumption reduced to travelled distance has efficiency  $E=91\%$  by controlled acceleration compared to uncontrolled acceleration, so that energy saving is 9%. Because of lower acceleration intensity, time to reach the same engine/vehicle speed is 59% greater during controlled acceleration then during uncontrolled one, but during grater time, travelled distance is as well 30% greater.

Energy (fuel) saving is realized due to:

- Controlled acceleration along the maximal engine torque efficiency function
- Reduced inertia resistance as a result of lower acceleration rate

Any driver can save fuel using this method because it relies on technical means, which are irrelevant to driving style.

Vehicle experiments confirmed possibility to increase engine efficiency while accelerating vehicle via numerical control by acceleration function.

## 6. REFERENCE

- [1] Hofmann D. at all – „Gasoline Engine Management“, Robert Bosch GmbH 3<sup>rd</sup> edition 2006
- [2] Belingardi G., Obradović J. – „Recent development in car body lightweight design – a contribution toward greener environment“, *Mobility & Vehicle Mechanics*, Vol. 38 No 4, 2012
- [3] Fuji Heavy Industries Ltd. – [http://drive2.subaru.com/Summer07\\_whatmakes.htm](http://drive2.subaru.com/Summer07_whatmakes.htm), “It's What Makes a Subaru, a Subaru: Subaru Intelligent Drive (SI-DRIVE)”, last accessed on February, 6. 2013.
- [4] Press Information: Fuji Heavy Industries Unveils the Revolutionary Intelligent Driving Enhancement System “SI-DRIVE”, Tokyo, April 14, 2006
- [5] Technicians Reference Booklet, MSA5P0161C, “Fuel Injection and Engine Management” Module 406, Subaru of America Inc. 2007. page 77.
- [6] Ford Motor Company – [http://media.ford.com/article\\_display.cfm?article\\_id=33965](http://media.ford.com/article_display.cfm?article_id=33965) „ALL-NEW FORD FOCUS FEATURES ECOMODE TO HELP DRIVERS PERFECT ECO-DRIVING TECHNIQUES“ Ford Motor Company Newsroom, last accessed on February, 8. 2013.
- [7] Friedrich K. and others – „Safety, Comfort and Convenience Systems“, Robert Bosch GmbH 2006
- [8] Simić D. – “Motorna vozila”, (in transl. „Motor vehicles“), Naučna knjiga (in transl. „Science book“), Belgrade 1977
- [9] Janković D., Ivanović G., Todorović J., Rakičević B. – „Teorija kretanja motornih vozila“ (in transl. „Vehicle motion theory“), Faculty of mechanical engineering in Belgrade 2001
- [10] Joly P., Duboc S. – „Common Rail Mapping on Power train Test Bench“, Technical Paper F2000 A054, Proceedings of Seoul 2000 FISITA World Automotive Congress 2000, Seoul, Corea, June 12-15 2000
- [11] Deur J, Paković D., Burgio G., Hrovat D. – „A Model Based Traction Control Strategy non-reliant on wheel sleep information“, *Mobility & Vehicle Mechanics*, Vol. 49 No 8, 2011
- [12] Jae-Book S., Byong-Cheol K., Dong-Chul S. – „Development of TCS Control Logic Based on Engine Throttle Control“, *Journal of mechanical science and technology*, Vol. 13 No 1
- [13] Minsuk S., Yaehyun K., Yeamyoun Y., Myuongho S. – „Design of a network based traction control system using a formalized design procedure“, FISITA F2006SC22 2006
- [14] Mencher B. at all – „Automotive Electrics Automotive Electronics“, Robert Bosch GmbH 5<sup>th</sup> edition 2007