



USE OF EDGE DETECTION OPERATORS FOR AGRICULTURE VIDEO SCENE FEATURE EXTRACTION FROM MANGO FRUITS

MANZA R.R.¹, GAIKWAD B.P.^{2*} AND MANZA G.R.¹

¹Department of CS and IT, Dr. Babasaheb Ambedkar Marathwada University, Aurangabad, MS, India.

²Department of CS, Vivekananda College of Science, Aurangabad, MS, India.

*Corresponding Author: Email- bharat.gaikwad08@gmail.com

Received: February 21, 2012; Accepted: March 06, 2012

Abstract- Mango fruit is one of the most popular, nutritionally rich fruit with unique flavor, fragrance, taste, and health promoting qualities making it a common ingredient in new functional fruits often called "super fruits". The Edge detection process detects outlines of mangos, mango quality evaluation and mango types, counting mangos, check Inflorescence quality. An edge is the boundary between mangos and the background. Simulink is a simulation modeling and design tool and GUI based diagram environment. The Simulink based customizable framework is designed for rapid simulation, implementation, and verification of video processing systems. In this work the comparative analysis of various mangos video edge detection methods is like Sobel, Prewitt, and Canny is presented.

Keywords- Mango Edge Detection, Sobel, Prewitt, Canny, Simulink, Sink, Report.

Citation: Manza R.R., Gaikwad B.P. and Manza G.R. (2012) Use of Edge Detection Operators for Agriculture Video Scene Feature Extraction from Mango Fruits. *Advances in Computational Research*, ISSN: 0975-3273 & E-ISSN: 0975-9085, Volume 4, Issue 1, pp.-50-53.

Copyright: Copyright©2012 Manza R.R., et al. This is an open-access article distributed under the terms of the Creative Commons Attribution License, which permits unrestricted use, distribution, and reproduction in any medium, provided the original author and source are credited.

Introduction:

"The king of the fruits" Mango is widely known as the "king of fruit", and that is not without a purpose. It is regarded as a valuable item of diet and a household remedy. It is rich in amino acids, vitamin C and E, flavonoids, beta carotene, niacin, calcium, iron, magnesium and potassium. India is the largest producer of mangoes, it accounts for less than one percent of the international mango trade. Mangoes are abundant during the summer season. In India, mango is mainly harvested in two seasons; the early season begins from February and lasts till June King of mango. The total mango production during 2010 stood at 15,026.7 lakh tones, according to data given by NHB. In work Simulink is a platform for multidomain simulation and model-based design of dynamic system. Simulation is an interactive tool for modeling simulating and analyzing dynamic multi domain system. You can build

a block diagram, simulate system behavior evaluate performance and refine the design. MATLAB provides you to immediate access to an extensive range of analysis and design tool. Simulink is ideal for control system design, Digital signal processing design, communication system design simulation option[6][9]. Edge detection is a fundamental tool used in most image processing applications to obtain information from the frames before feature extraction and object segmentation. This process detects outlines of an object and boundaries between objects and the background in the image. An edge detection filter is also used to improve the appearance of blurred. The basic edge detection operator is a matrix area gradient operation that determines the level of variance between different pixels. The edge detection operator is calculated by forming a matrix centered on a pixel chosen as the center of the matrix area. If the value of this matrix area is above a given

threshold, then the middle pixel is classified as an edge. Examples of gradient-based edge detectors are Sobel, Prewitt, and Canny operators.

Edge Detection

The edge detection process serves to simplify the analysis of images by drastically reducing the amount of data to be processed, while at the same time preserving useful structural information about object boundaries. There is certainly a great deal of diversity in the applications of edge detection. Edge detectors of some kind, particularly step edge detectors, have been an essential part of many computer vision systems. There are many edge detection operators available, each designed to be sensitive to certain types of edges. Certain criteria involved in selection of an edge detection operator include edge orientation. There are mainly exist several edge detection methods Sobel [9], Prewitt [10], Canny [11]. These methods have been proposed for detecting transitions in video images. Edges are significant local changes of intensity in an image. Edges typically occur on the boundary between two different regions in an image.

Important features can be extracted from the edges of an image (e.g., corners, lines, curves).

Object boundary (discontinuity in depth and/or surface color and texture) Surface boundary (discontinuity in surface orientation and/or surface color and texture)

The Four Steps of Edge Detection

- a. **Smoothing:** suppress as much noise as possible, without destroying the true edges.
- b. **Enhancement:** apply a filter to enhance the quality of the edges in the image (sharpening).
- c. **Detection:** determine which edge pixels should be discarded as noise and which should be retained (usually, thresholding provides the criterion used for detection).
- d. **Localization:** determine the exact location of an edge (sub-pixel resolution might be required for some applications, that is, estimate the location of an edge to better than the spacing between pixels). Edge thinning and linking are usually required in this step.

Edge Detection Techniques:

Sobel Edge Detection

In this work, Sobel which is an edge detection method is considered. This method is preferred will use in this work. The Sobel edge detector uses two masks, one vertical and one horizontal. These masks are generally used 3x3 matrices. Especially, the matrices which have 3x3 dimensions are used in matlab. The Sobel method finds edges using the Sobel approximation to the derivative. It returns edges at those points where the gradient of I is maximum [9]. The operator consists of a pair of 3X3 convolution kernels as shown in fig.1. These kernels are designed to respond maximally to edges running vertically and horizontally relative to the pixel grid [6].

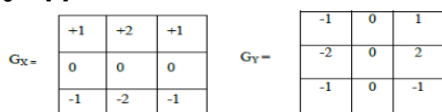

Fig. 1- Sobel edge detection operator

$$\text{Edge Magnitude} = \sqrt{x^2 + y^2}$$

$$\text{Edge Direction} = \tan^{-1}\left(\frac{y}{x}\right)$$

Main steps in edge detection using masks:-

Smooth the input image

- 1) $\hat{f}(x, y) = f(x, y) * G(x, y)$
- 2) $\hat{f}_x = \hat{f}(x, y) * M_x(x, y)$
- 3) $\hat{f}_y = \hat{f}(x, y) * M_y(x, y)$
- 4) $\text{magn}(x, y) = |\hat{f}_x| + |\hat{f}_y|$
- 5) $\text{dir}(x, y) = \tan^{-1}(\hat{f}_y / \hat{f}_x)$
- 6) If $\text{magn}(x, y) > T$, then possible edge point

Prewitt Edge Detection

The Prewitt method finds edges using the Prewitt approximation to the derivative. It returns edges at those points where the gradient of I is maximum. It is similar to the Sobel operator and is used for detecting Vertical and horizontal edges in video image.

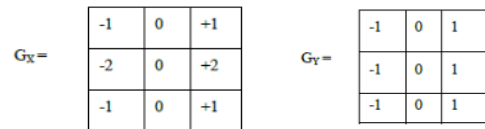

Fig. 2- Prewitt edge detection operator

$$\text{Edge Magnitude} = \sqrt{x^2 + y^2}$$

$$\text{Edge Direction} = \tan^{-1}\left(\frac{y}{x}\right)$$

Canny Edge Detector

The Canny method finds edges by looking for local maxima of the gradient of I. The gradient is calculated using the derivative of a Gaussian filter. The method uses two thresholds, to detect strong and weak edges, and includes the weak edges in the output only if they are connected to strong edges [12]. This method is therefore less likely than the others to be fooled by noise, and more likely to detect true weak edges [4].

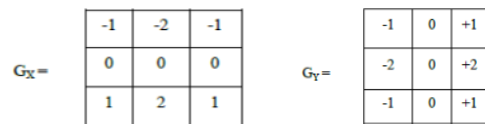

Fig. 3- Canny edge detection operator

Implementation Analysis and Preliminary Report:

The aim of this paper work is to implement an efficient methodology to edge detection process detects outlines of mango fruits and boundaries between objects and the background in the video image. The fruit size is another quality attribute used by farmers – the bigger size mango fruit is considered of better quality. The size is estimated by calculating the area covered by the fruit image. To compute the area, first the fruit image is binarized to separate the fruit image from its background. The farmers use shape irregularity as a quality measure. Fruits having irregular shapes are considered of better quality. Weestimated it from the outer profile of the fruit image. The estimation steps are described below. (1) Using an edge tracking operator to estimate the outmostedge points of the mangos fruit image.(2) Link the outermost edge points to form the outermost profile of the fruit image[18].Simulink handles stream processing implicitly by managing the flow of data through the blocks that make up a Simulink model. Simulink is an interac-

tive graphical environment for modeling and simulating dynamic systems that uses hierarchical diagrams to represent a system model. It includes a library of general-purpose, predefined blocks to represent algorithms, Analysis & Enhancement, sources, sinks, and system hierarchy. The Sobel method finds edges using the Sobel approximation to the derivative. It returns edges at those points where the gradient of image is maximum. The Canny method finds edges by looking for local maxima of the gradient of image. The gradient is calculated using the derivative of a Gaussian filter. The Roberts method finds edges using the Roberts approximation to the derivative. It returns edges at those points where the gradient of the image is maximum. The Edge detection block outputs a binary image with the edges shown in white. This output is displayed in the Edges window. The compositing block accepts the original video frames, shown in the original window, and the output of the edge detection block as two inputs at its Figure 5, Figure 6 & Mask ports, respectively. Edge takes a grayscale image as its input, and returns a binary image of the same size as the input image, with 1's where the function finds edges and 0's elsewhere. Frame rate or frame frequency is the frequency at which an imaging device produces unique consecutive images, frames that applies equally well to compute graphics, video cameras, film cameras and motion capture system. Frame rate is most often expressed in frames per second and is also uttered in progressive scan monitors as Hertz (Hz). The frame rate display block calculates and displays the average update rate of the input signals. Computer Vision System Toolbox provides a library of blocks specifically for the design of computer vision and video processing systems. In following framework various blockset are used.

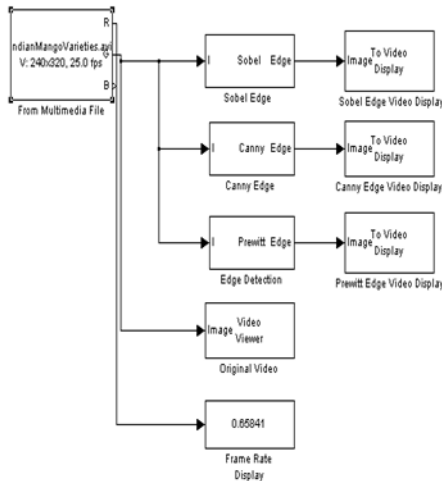

Fig. 4- framework of video processing systems

- Sources/From Multimedia File: On Windows reads video frames and/or audio samples from a compressed or uncompressed multimedia file. Multimedia files can contain audio, video, or audio and video data[17].
- Analysis & Enhancement/Edge Detection: Finds the edges in an input image using Sobel, Prewitt, and Canny methods.
- Sinks/To Video Display: Displays a video stream.
- Sinks/Frame Rate Display: Calculate and display the frame rate of the input signal [15].

- Report Generator/launch report: Clicking on this block runs the Report Generator using the "report" command [2].

Mango Edge detection by Prewitt, Sobel, and Canny Operator

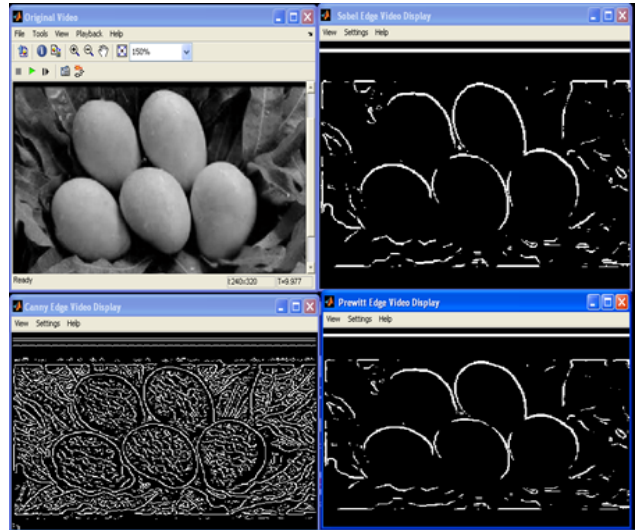

Fig. 5- a) Original b) Prewitt c) Sobel d) Canny

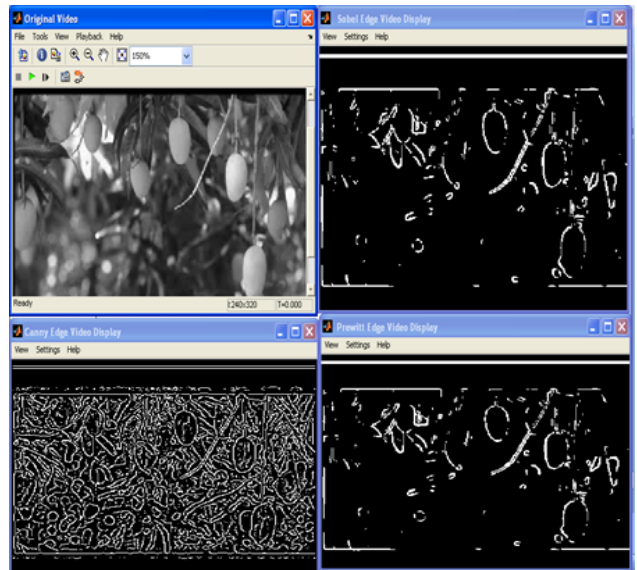

Fig. 6- a) Original b) Prewitt c) Sobel d) Canny

Conclusion

In this paper, we have thoroughly analyze the effect of edge detection operator like Prewitt,Sobel and Canny on mangos video scene .The proposed operator's to Implementation of this methodology using Simulink blockset is more useful for Idea Edge detection to detect outlines of mango, Identify Mangos shape, types and boundaries. This system isapplicable for automatic Mango quality evaluation, Inflorescence quality and diseases analysis, ripeness evaluation .The performance for edge detection in mangos video evaluated both subjectively and objectively. The subjective evaluation of edge detected video images show that proposed operator, Sobel and Prewitt and Canny operator exhibit better performances respectively.

References

- [1] Zhenfeng Li, Ning Wang, Vijaya Raghavan G.S. (2009) *Journal of Food Engineering*.
- [2] Idstein H., Schreier P. (2010) *Phytochemistry*, 24(10), 2313-2316.
- [3] The MathWorks (2003) *The MathWorks, Writing S-Functions-Version 5*.
- [4] www.mathworks.com/res/viprocessing.viewed on Jan 2012.
- [5] Hong Shan Neoh and Asher Hazanchuk (2005) *Altera Corporation*.
- [6] Canny J. (1986) *IEEE Trans. Pattern Analysis and Machine Intelligence*, 8, 679-714.
- [7] Subashini P., Krishnaveni M. (2011) *International Journal of Engineering Science and Technology*.
- [8] Chethan H.K. and Hemantha Kumar G. (2010) *International Journal of Computer Applications*.
- [9] Sobel I. (1990) *An Isotropic 3×3 Gradient Operator, Machine Vision for Three-Dimensional Scenes*, 376-379.
- [10] Prewitt J. (1970) *Picture Processing and Psychopictorics*.
- [11] Canny J (1986) *IEEE Transactions on Pattern Analysis and Machine Intelligence*, 8, 679-700,
- [12] Canny J. (1983) *Master's thesis, MIT*.
- [13] Mamta Juneja, Parvinder Singh Sandhu (2009) *International Journal of Computer Theory and Engineering*.
- [14] Yakimovsky Y. (1976) *JACM*, 23(4), 598-619.
- [15] Ziou D. and Tabbone S. (1998) *International Journal of Pattern Recognition Image Analysis*.
- [16] Shervan Fekri Ershad (2011) *Texture Classification Approach Based on Combination of Edge & Co-occurrence and Local Binary Pattern*.
- [17] Stauffer C. (2003) *2nd IEEE Workshop on Event Mining*, 4.
- [18] Youssef Al Ohali (2011) *Design and implementation Computer and Information Sciences*.