

# Available Transfer Capacity with Renewable Energy

<sup>1</sup>Haris K V, <sup>1</sup>Hrudhya Kurian C

<sup>1</sup>PG Scholar Thejus engineering college, Thrissur

[hariskv.kv@gmail.com](mailto:hariskv.kv@gmail.com), [hrudhyakurianc888@gmail.com](mailto:hrudhyakurianc888@gmail.com)

**Abstract-** Electric utility around the world is facing with restructuring, deregulation and privatization. And transmission network tend to be heavily loaded and transmission services become one of the most critical element. Power system transfer capability indicates how much inter area power transfers can be increased without compromising system security. For both planning and operation of the bulk power market, accurate identification of this capability is very important. Available transfer capacity (ATC) as the amount of transfer capacity that is available at a certain time for purchase or sale in the electric power market under different system conditions. The computation of ATC is very important to keep reliability and security of deregulated power system. An accurate ATC computation is also very important to the transmission system. If the computed ATC is less than the ATC of the system, the transmission of power will not be efficient economically, if the computed ATC is more than the ATC of the system, the transmission will be operating in a dangerous state and any power increased will stand a chance to collapse the whole system and the result of that is disastrous. The computation of real time ATC value is very important sine it is not fixed for a line. The value of ATC for a transmission line will vary with many cases. This project also focuses on the variation of ATC value with varying renewable energy sources, with increasing load demand and with incorporation of UPFC controllers.

**Keywords-** ATC, UPFC, TTC, ETC, PTDF, etc

## I. INTRODUCTION

Nowadays the demand and of non renewable energy is increasing day by day. To overcome this issue we go for renewable energy sources. So a new method is implementing ATC with renewable energy. The commonly used renewable energy sources are wind, tide, solar, fuel cell, geothermal, etc. Here we are choosing the renewable energy source as solar energy. To calculate the available transfer capacity of six bus system following steps are (a) to study the impact of renewable energy variation on ATC value. (b) To study the variation of ATC with load demand. (c) To calculate ATC of the proposed six bus system with the incorporation of UPFC controller [1].

## II. AVAILABLE TRANSFER CAPABILITY

Available Transfer Capability (ATC) is a measure of the transfer capability remaining in the physical transmission network for further commercial activity over and above already committed uses [2]. Mathematically, ATC is defined as the Total Transfer Capability (TTC) less the Transmission Reliability Margin (TRM), less the sum of Existing Transmission Commitment (ETC) (which includes retail customer service) and the Capacity benefit Margin (CBM). ATC can be expressed as:

$$ATC = TTC - TRM - CBM - ETC$$

Where, TTC=Total transfer capability, TRM=Transmission reliability margin, CBM=Capacity benefit margin, ETC=Existing transmission commitments etc.

### A. Transfer capability

Transfer capability is the measure of the ability of interconnected electric systems to reliably move or transfer power from one area to another over all transmission lines (or paths) between those areas under specified system conditions. The units of transfer capability are in terms of electric power, generally expressed in megawatts (MW).

### B. Transmission reliability margin (trm)

Transmission Reliability Margin (TRM) is defined as that amount of transmission transfer capability necessary to ensure that the interconnected transmission network is secure under a reasonable range of uncertainties in system conditions.

### **C. Capacity benefit margin**

Capacity Benefit Margin (CBM) is defined as that amount of transmission transfer capability reserved by load serving entities to ensure access to generation from interconnected systems to meet generation reliability requirements.

### **D. Limits to transfer capability**

The ability of interconnected transmission networks to reliably transfer electric power may be limited by the physical and electrical characteristics of the systems including any one or more of the following:

1. Thermal Limits — Thermal limits establish the maximum amount of electrical current that a transmission line or electrical facility can conduct over a specified time period before it sustains permanent damage by overheating.
2. Voltage Limits — System voltages and changes in voltages must be maintained within the range of acceptable minimum and maximum limits.
3. Stability Limits — the transmission network must be capable of surviving disturbances through the transient and dynamic time periods following the disturbance.

Therefore, the TTC becomes:

TTC = Minimum of {Thermal Limit, Voltage Limit, Stability Limit}

## **III. METHODS OF ATC CALCULATION**

### **A. Continuation power flow method (cpf)**

Continuation Power Flow (CPF) is first introduced for determining the maximum load ability however; it is adaptable for other applications including ATC computation without changing its principle. CPF method is based on full AC power flow solution to incorporate the effects of reactive power flows, voltage limits and voltage collapse as well as thermal loading effects [3]. But the use of CPF in determining ATC is complex and the computational time increases when the contingency analyses are introduced for all possible cases. Consequently, it is not suitable for on-line applications in its present form. The CPF algorithm effectively increases the controlling parameter in discrete steps and solves the resulting power flow problem at each step. The procedure is continued until a given condition or physical limit preventing further increase is reached. Hence, the speed of proposed method is very slow. Consequently, it is not suitable for online applications in its present form [4].

### **B. Optimal power flow method (opf)**

Optimal Power Flow approach is another approach used to calculate ATC. The main idea is to formulate an optimization problem such that the dominant elements are the equality and inequality constraints of power flow. But solution of optimization problem for large systems becomes very time consuming and hence this approach cannot be applied in real-time for large systems. OPF methods are widely used to determine ATC in power corridors of the system. However these optimization methods are suitable in case of open access system where there is a possibility of power transactions occurring from any point to any point.

### **C. Repeated power flow method (rpf)**

Repeated power flow method was proposed to explore its computational advantage. This approach starts from a base case, and repeatedly solves the power flow equations each time increasing the power transfer by a small increment until an operation limit is reached. The advantage of this approach is its simple implementation and the ease to take security constraints into consideration but takes long time for iteration.

### **D. Sensitivity based power flow method**

Sensitivity based power flow methods have been proposed for fast computation of ATC. This method is based on power transfer distribution factors (PTDFs) using DC and AC load flow approach. DC power transfer distribution factors (DCPTDF) based method is reported for fast calculation of ATC. But this method has a poor accuracy when X/R ratio is low due to assumptions involved. This is

very useful due to its simplicity in calculation and speedy outcomes [5]. The DC load flow based approaches are fast using assumptions for DC load flow. Many researchers have presented more accurate methods considering reactive power flow based on AC load flow formulation for ATC calculation using the sensitivity factors. These sensitivity factors are based on linear incremental power flow, which are very simple to define and calculate [7]. In ACPTDF method, a sequential full ac power flow is not required and hence has a high calculation speed. Studies have indicated that CPF and OPF based methods are accurate but very time consuming, especially for large systems [6]. Among the existing methods of ATC calculation, PTDF based methods are fastest.

### III. SIMULATION

The software used in this paper to calculate ATC is MATLAB and the results are tested using MATLAB programming in the version MATLAB2 R2013b. MATLAB is widely used in academic and research institutions as well as industrial enterprises. The MATLAB application is built around the MATLAB language, and most use of MATLAB involves typing MATLAB code into the Command Window or executing text files containing MATLAB code, including scripts and/or functions.

#### A. Proposed 6 bus system

The 6-bus test system is considered here to demonstrate the calculations of ATC using proposed method. Bus 1 is the swing bus, bus 2 and 3 are generator buses whereas bus 4, 5 and 6 are load buses. Code 0, Code 1, Code 2 for the load buses, the slack bus and the voltage controlled buses, respectively. The figure below shows the one-line diagram of 6 bus system [8].

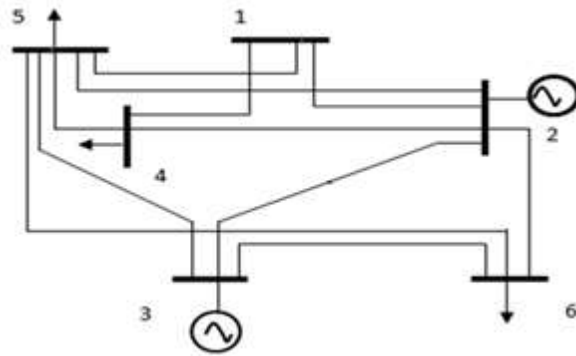

#### B. Line data for the 6 bus system

From	To	R(p.u)	X(p.u)	Thermal limit
1	2	0.1	0.2	40
1	4	0.05	0.2	80
1	5	0.08	0.3	60
2	3	0.05	0.25	40
2	4	0.05	0.10	60
2	5	0.1	0.3	30
2	6	0.07	0.20	90
3	5	0.12	0.26	70
3	6	0.02	0.10	100
4	5	0.1	0.40	20
5	6	0.1	0.30	40

Bus No.	Bus Code.	Voltage magnitude(V)	Angle (degree)	Load (MW)	Load (Mvar)	Generator (MW)	Generator (Mvar)
1	1	1.0	0.0	0	0	0.0	0.0
2	2	1.05	0.0	0	0	69.36	0.0
3	2	1.07	0.0	0	0	77.47	0.0
4	0	1.0	0.0	70	70	0.0	0.0
5	0	1.0	0.0	70	70	0	0.0
6	0	1.0	0.0	70	70	0	0.0

Bus data for the proposed system

## V. SIMULATION RESULTS

Renewable energy power generation can reduce human dependence on fossil fuels and environment and climate issues. It is an important part of the world power industry development to vigorously promote the new energy power generation. Solar power represents one of the new energy power generation industry developed rapidly [9]. With the development of renewable energy power generation technology and increase of power load demand, renewable energy power generation can not only service specific users outside power grid,

but also can massively incorporate into the power grid. Here we study the variation of ATC value with some connected solar energy sources. Since the solar power output is not fixed we imaging an upper and lower limit for the solar power output in MW [10].

In order to make comparable research, 2 kinds of penetration level of renewable energy power generation are set as:

Penetration level 1: No solar source is added.

Penetration level 2: A solar source having an out 20 to 25 MW power is connected in bus five as shown in the figure below. The output is also given below.

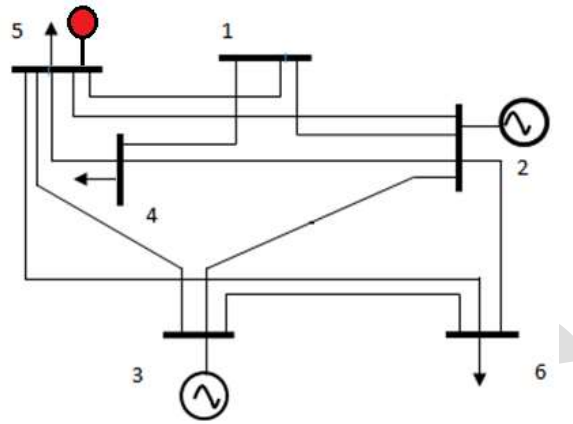

Line No	Sending bus	Receiving bus	ATC in MW Without renewable	ATC in Mw with renewable 20- 25MW
1	1	2	0.3635	0.4311-0.4478
2	1	4	0.5609	0.6956-0.7291
3	1	5	0.4509	0.5051-0.5186
4	2	3	0.1911	0.2331-0.2546
5	2	4	0.4052	0.5567-0.5936
6	2	5	0.2166	0.3896-0.4794
7	2	6	1.6251	1.6307-1.7042
8	3	5	0.9912	0.9958-0.9970
9	3	6	0.2435	0.2595-0.2676
10	4	5	0.3319	0.4734-0.5549
11	5	6	1.3462	1.6933-1.8701

**CONCLUSION**

An accurate ATC computation is also very important to the transmission system. If the computed ATC is less than the ATC of the system, the transmission of power will not be efficient economically, if the computed ATC is more than the ATC of the system, the transmission will be operating in a dangerous state and any power increased will stand a chance to collapse the whole system and the result of that is disastrous. In this project we use a simple and efficient method for determining the available transfer capability of the system and studying its variation by renewable energy, varying load demands and with connected UPFC controllers. The MATLAB programs for all ATC calculations are done and the results presented in a tabular data for each section.

**REFERENCES:**

1. A. Khairuddin, ; N. A. Bakar "ATC Determination Incorporating Wind Generation" 2013 IEEE 7th International Power Engineering and Optimization Conference (PEOCO2013), Langkawi, Malaysia. 3-4 June.
2. Anup Kumar and Mukesh Kumar "Available Transfer Capability Determination Using Power Transfer Distribution Factors", International Journal of Information and Computation Technology, Volume 3,(2013).
3. M. Y. Patel and A. A. Girgis "New Iterative Method for Available Transfer Capability Calculation", 2011 IEEE.
4. G. Hamoud, "Assessment of available transfer capability of transmission systems", IEEE Transactions on Power systems 15 (1) (2000) 27-32.

5. G.C. Ejebe, J. Tong, J.G. Waight, J.G. Flame, X. Wang, W.F. Tinney, "Available Transfer Capability Calculations", IEEE Transactions on Power Systems, Vol. 13, No. 4, November 1998.
6. Nirmal Solanki , Mr. U. L. Makwana "Calculation of Available Transfer Capability Using AC Load Flow Method", International Journal for Scientific Research & Development Vol. 2, Issue 01, 2014.
7. Poornima Pankajam T, J Srinivasa Rao, J Amarnath "ATC Enhancement with FACTS Devices Considering Reactive Power Flows Using PTDF", International Journal of Electrical and Computer Engineering (IJECE) Vol. 3, No. 6, December 2013, pp. 741~750.
8. Rajnikant H. Bhesdadiya, Dr. Rajesh M. Patel "Available Transfer Capability Calculation Methods: A Review", International Journal of Advanced Research in Electrical, Electronics and Instrumentation Engineering, Vol. 3, Issue 1, January 2014.
9. Luis Luna, Jorge Martínez Carlos, Valero Pacual and Vanesa Valiño "impact of wind power generation on the atc value", 17th Power Systems Computation Conference Stockholm Sweden - August 22-26, 2011.
10. Mojgan Hojabri and Hashim Hizam "Available Transfer Capability Calculation", Applications of MATLAB in Science and Engineering.