

## IDENTIFICATION OF SQUATS IN RAILWAY INFRASTRUCTURE

Rubina Sultana<sup>1</sup>

Asma Mehdia<sup>2</sup>

<sup>1</sup> Rubina Sultana has completed M.TECH in Embedded Systems

<sup>2</sup> Asma Mehdia has completed M.TECH in Computer Science

### ABSTRACT:

Squats have become a major tricky problem in the track of many railways. In the quest for the root causes of squats, it is observed that they are occasionally found at locations of track stiffness changes such as at fish-plated insulated joints and at switches and crossings. Obviously, there should be other factors in the track, which, together with the stiffness change, have played important roles otherwise there will be squats at all such locations. A validated hybrid multibody-finite element model of vehicle-track vertical interaction is extended to simulate the frictional dynamic rolling contact at a fish-plated insulated joint in order to identify such factors. Elastic-plastic rail material property is taken into account. It is found that it is track short defect in the preload condition of the bolts and the contact between the fishplates and the rail head, which together with the stiffness change, causes large normal and longitudinal contact force variation at the fishplate end so that differential wear and differential plastic deformation may accumulate at a fixed location. With proper wavelength, the accumulated rail top geometry deviation may grow into a squat. The significance of the present work lies in that other track short defects such as damaged and improper railpads and fastening, and ballast voids may also have such effects, which may be responsible for a large portion of the many squats in the tracks. This gives the direction for further work.

KEYWORDS: Squats, Rail pads, Wavelength, Switches, Crossings.

### INTRODUCTION

The Embedded Technology is now in its prime and the wealth of Knowledge available is mind-blowing. Embedded System is a combination of hardware and software. Embedded technology plays a major role in integrating the various functions associated with it. This needs to tie up the various sources of the Department in a closed loop system. This proposal greatly reduces the manpower, saves time and operates efficiently without human interference. This project puts forth the first step in achieving the desired target. With the advent in technology, the existing systems are developed to have in built intelligence.

### LITERATURE SURVEY

Three factors compose the basis of a forest fire: the fire source, environmental elements and combustible material. A forest fire usually occurs as the result of their combined effects (Song et al., 2006). According to the Canada Fire Weather Index Forecast Model, the moisture content of the combustible material plays an important role in forest fires, which means the probability of forest fires depends on the moisture content (Tian et al., 2006). Therefore, the moisture content of combustible materials is a major point of assessment and predicts whether a fire will take place. The moisture content has much to do with relative humidity in the atmosphere, air temperature, wind and similar factors (Shu et al., 2003; Zhang, 2004). Water evaporation can be directly affected by relative humidity. At the same time, the physical properties of combustible materials can be changed indirectly by air temperature. Thus, relative humidity and air temperature are regarded as the two main factors which affect the moisture content of the fuel. Therefore, to

reflect the moisture content indirectly, these two parameters are the main objects of our investigation, which should provide an important basis for the prediction and monitoring of forest fires. Certainly, forest fires are also caused by other factors, such as the active degree of thunder and lightning above the forest, human factors, wind speed, and condition of area vegetation. However, these factors will be ignored in our discussion.

## METHODOLOGIES

### 1) Power Supply

The power supply section is the section which provide +5V for the components to work. IC LM7805 is used for providing a constant power of +5V. The ac voltage, typically 220V, is connected to a transformer, which steps down that ac voltage down to the level of the desired dc output. A diode rectifier then provides a full-wave rectified voltage that is initially filtered by a simple capacitor filter to produce a dc voltage. This resulting dc voltage usually has some ripple or ac voltage variation. A regulator circuit removes the ripples and also retains the same dc value even if the input dc voltage varies, or the load connected to the output dc voltage changes. This voltage regulation is usually obtained using one of the popular voltage regulator IC units.

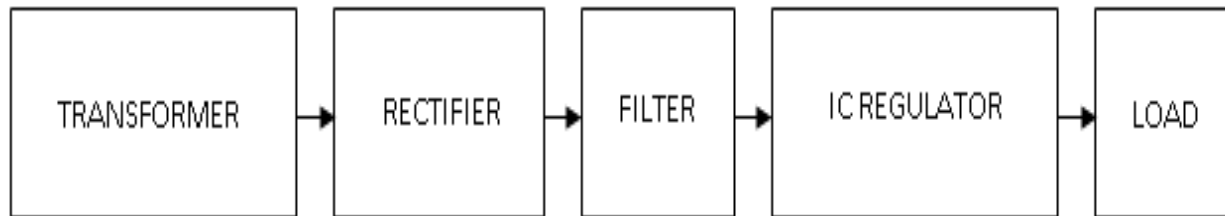

Figure 1. Block Diagram of Power Supply

### 2) Transformer

Transformers convert AC electricity from one voltage to another with little loss of power. Transformers work only with AC and this is one of the reasons why mains electricity is AC. Step-up transformers increase voltage, step-down transformers reduce voltage. Most power supplies use a step-down transformer to reduce the dangerously high mains voltage (230V in India) to a safer low voltage. The input coil is called the primary and the output coil is called the secondary. There is no electrical connection between the two coils; instead they are linked by an alternating magnetic field created in the soft-iron core of the transformer. Transformers waste very little power so the power out is (almost) equal to the power in. Note that as voltage is stepped down current is stepped up. The transformer will step down the power supply voltage (0-230V) to (0- 6V) level. Then the secondary of the potential transformer will be connected to the bridge rectifier, which is constructed with the help of PN junction diodes. The advantages of using bridge rectifier are it will give peak voltage output as DC.

### 3) Rectifier

There are several ways of connecting diodes to make a rectifier to convert AC to DC. The bridge rectifier is the most important and it produces full-wave varying DC. A full-wave rectifier can also be made from just two diodes if a centre-tap transformer is used, but this method is rarely used now that diodes are cheaper. A single diode can be used as a rectifier but it only uses the positive (+) parts of the AC wave to produce half-wave varying DC

### 4) Bridge Rectifier

When four diodes are connected as shown in figure, the circuit is called as bridge rectifier. The input to the circuit is applied to the diagonally opposite corners of the network, and the output is taken from the remaining two corners. Let us assume that the transformer

is working properly and there is a positive potential, at point A and a negative potential at point B. the positive potential at point A will forward bias D3 and reverse bias D4.

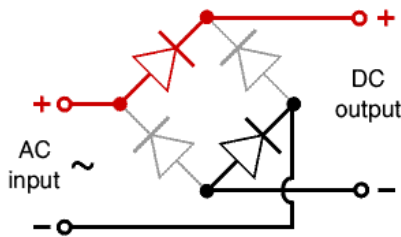

Figure 2. Bridge Rectifier

The negative potential at point B will forward bias D1 and reverse D2. At this time D3 and D1 are forward biased and will allow current flow to pass through them; D4 and D2 are reverse biased and will block current flow.

One advantage of a bridge rectifier over a conventional full-wave rectifier is that with a given transformer the bridge rectifier produces a voltage output that is nearly twice that of the conventional full-wave circuit.

- i. The main advantage of this bridge circuit is that it does not require a special centre tapped transformer, thereby reducing its size and cost.
- ii. The single secondary winding is connected to one side of the diode bridge network and the load to the other side as shown below.
- iii. The result is still a pulsating direct current but with double the frequency.

#### PROBLEM DEFINITION:

ZigBee is used in applications that require a low data rate, long battery life, and secure networking. ZigBee has a defined rate of 250 kbit/s, best suited for periodic or intermittent data or a single signal transmission from a sensor or input device. Applications include wireless light switches, electrical meters with in-home-displays, traffic management systems, and other consumer and industrial equipment that requires short-range wireless transfer of data at relatively low rates. The technology defined by the ZigBee specification is intended to be simpler and less expensive than other [WPANs](#), such as [Bluetooth](#) or [Wi-Fi](#). Since ZigBee can be used almost anywhere, is easy to implement and needs little power to operate, the opportunity for growth into new markets, as well as innovation in existing markets, is limitless. Here are some facts about ZigBee:

- With hundreds of members around the globe, ZigBee uses the 2.4 GHz radio frequency to deliver a variety of reliable and easy-to-use standards anywhere in the world.
- Consumer, business, government and industrial users rely on a variety of smart and easy-to-use ZigBee standards to gain greater control of everyday activities.
- With reliable wireless performance and battery operation, ZigBee gives you the freedom and flexibility to do more.
- ZigBee offers a variety of innovative standards smartly designed to help you be green and save money.

ZigBee is a wireless technology developed as an open global standard to address the unique needs of low-cost, low-power, wireless sensor networks. The standard takes full advantage of the IEEE 802.15.4 physical radio specification and operates in unlicensed bands worldwide at the following frequencies: 2.400–2.484 GHz, 902-928 MHz and 868.0–868.6 MHz.

1. The power levels (down from 5v to 3.3v) to power the zigbee module.
2. The communication lines (TX, RX, DIN and DOUT) to the appropriate voltages.

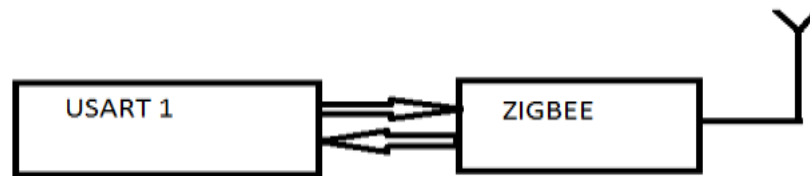

Figure 3. Communications between USART and ZIGBEE

The Zigbee module acts as both transmitter and receiver. The Rx and Tx pins of ZIGBEE are connected to Tx and Rx of 8051 microcontroller respectively. The data's from microcontroller is serially transmitted to Zigbee module via UART port. Then Zigbee transmits the data to another Zigbee. The data's from Zigbee transmitted from Dout pin. The Zigbee from other side receives the data via Din pin. ZigBee module. The [€1 coin](#), shown for size reference, is about 23 mm in diameter. **ZigBee** is a [specification](#) for a suite of high level communication protocols using small, low-power [digital radios](#) based on the IEEE 802.15.4-2003 [standard](#) for Wireless Personal Area Networks (WPANs), such as wireless headphones connecting with cell phones via short-range radio. The technology defined by the [ZigBee specification](#) is intended to be simpler and less expensive than other WPANs, such as [Bluetooth](#). ZigBee is targeted at [Radio-Frequency](#) (RF) applications that require a low data rate, long battery life, and secure networking.

## Overview

ZigBee is a low-cost, low-power, [wireless mesh networking](#) proprietary standard. The low cost allows the technology to be widely deployed in wireless control and monitoring applications, the low power-usage allows longer life with smaller batteries, and the mesh networking provides high reliability and larger range.

The ZigBee Alliance, the standards body that defines ZigBee, also publishes application profiles that allow multiple [OEM](#) vendors to create interoperable products. The current list of application profiles either published or in the works are:

- Home Automation
- ZigBee Smart Energy
- Commercial Building Automation
- Telecommunication Applications
- Personal, Home, and Hospital Care
- Toys

The relationship between IEEE 802.15.4 and ZigBee is similar to that between [IEEE 802.11](#) and the [Wi-Fi Alliance](#). The ZigBee 1.0 specification was ratified on 14 December 2004 and is available to members of the ZigBee Alliance. Most recently, the ZigBee 2007 specification was posted on 30 October 2007. The first ZigBee Application Profile, Home Automation, was announced 2 November 2007.

ZigBee operates in the Industrial, Scientific and Medical ([ISM](#)) radio bands; 868 MHz in Europe, 915 MHz in the USA and Australia, and 2.4 GHz in most jurisdictions worldwide. The [technology](#) is intended to be simpler and less expensive than other [WPANs](#) such as [Bluetooth](#). ZigBee chip vendors typically sell integrated radios and microcontrollers with between 60K and 128K flash memory, such as the [Jennic](#) JN5148, the Free scale MC13213, the Ember EM250 and the [Texas Instruments](#) CC2430. Radios are also available stand-alone to be used with any processor or microcontroller. The first stack release is now called Zigbee 2004. The second stack release is called Zigbee 2006, and mainly replaces the [MSG/KVP](#) structure used in 2004 with a "cluster library". The 2004 stack is now more or less obsolete. Zigbee 2007, now the current stack release, contains two stack profiles, stack profile 1 (simply called

ZigBee), for home and light commercial use, and stack profile 2 (called ZigBee Pro). ZigBee Pro offers more features, such as multi-casting, many-to-one routing and high security with Symmetric-Key Key Exchange (SKKE), while ZigBee (stack profile 1) offers a smaller footprint in RAM and flash. Both offer full mesh networking and work with all ZigBee application profiles. ZigBee 2007 is fully backward compatible with ZigBee 2006 devices: A ZigBee 2007 device may join and operate on a ZigBee 2006 network and vice versa. Due to differences in routing options, ZigBee Pro devices must become non-routing ZigBee End-Devices (ZEDs) on a ZigBee 2006 or ZigBee 2007 network, the same as ZigBee 2006 or ZigBee 2007 devices must become ZEDs on a ZigBee Pro network. The applications running on those devices work the same, regardless of the stack profile beneath them.

## IMPLEMENTATION

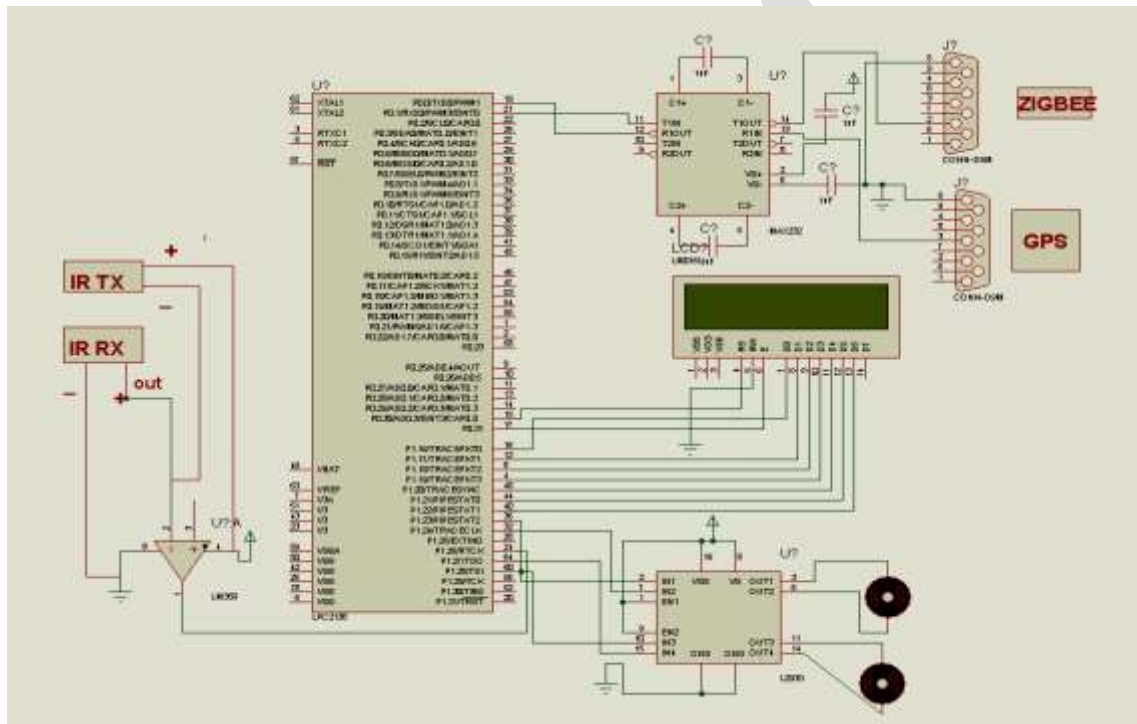

Figure 4.1 SCHEMATIC DAIGRAM

### WORKING PRINCIPLE:

This system involves the design of crack finding robot for finding cracks in railway tracks. Here the microcontroller is interfaced with Robot, Zigbee, and GPS, LCD and crack sensor. The IR sensor senses the voltage variations from the crack sensor and then it gives the signal to the microcontroller. The microcontroller checks the voltage variations of the measured value with the threshold value. If the microcontroller detects the crack, it immediately gets the location information using GPS and sends that location and crack information to the control section. The control section displays the location in map. The LCD is used to display the current status of this system.

- Working of IR sensor is very simple and working principle is totally based on change in resistance of IR receiver. Here in this sensor we connect IR receiver in reverse bias so it give very high resistance if it is not exposed to IR light. The resistance in this case is in range of Mega ohms, but when IR light reflected back and falls on IR receiver. The resistance of IR receiver it comes in range between Kilo ohms to hundred of ohms. We convert this change in resistance to change in voltage. Then

this voltage is applied to a comparator IC which compares it with a threshold level. If voltage of sensor is more than threshold then output is high else it is low which can be used directly for microcontroller. The voltage variations from the crack sensor and connected to LM358 which is operational amplifier for uniform signal and then it give the signal to the microcontroller P1.26. The microcontroller checks the voltage variations of the measured value with the threshold value. If the microcontroller detects the crack, it immediately gets the location information using GPS and sends that location and crack information to the control section.

- The basis of the GPS is a constellation of satellites that are continuously orbiting the earth. These satellites, which are equipped with atomic clocks, transmit radio signals that contain their exact location, time, and other information. The radio signals from the satellites, which are monitored and corrected by control stations, are picked up by the GPS receiver.
- A GPS receiver needs only three satellites to plot a rough, 2D position, which will not be very accurate. Ideally, four or more satellites are needed to plot a 3D position, which is much more accurate. GPS is communicated through serial communication and connected to UART0, and updated to control section through Zigbee via serial communication.
- The Zigbee module acts as both transmitter and receiver. The Rx and Tx pins of ZIGBEE are connected to Tx and Rx of ARM7 respectively. The data's from ARM 7 is serially transmitted to Zigbee module via UART1 port.
- Then Zigbee transmits the data to another Zigbee. The data's from Zigbee transmitted from Dout pin. The Zigbee from other side receives the data via Din pin.
- The LCD is used to display the current status of this system here it is 16X2, a **16x2 LCD** means it can display 16 characters per line and there are 2 such lines. In this LCD each character is displayed in 5x7 pixel matrix. LCD standard requires 3 control lines and 8 I/O lines for the data bus. **8 data pins D7:D0** Bi-directional data/command pins. Alphanumeric characters are sent in ASCII format. **RS: Register Select** RS = 0, Command Register is selected RS = 1, Data Register is selected **R/W: Read or Write** 0 Write, 1-> Read **E: Enable (Latch data)** Used to latch the data present on the data pins. A high-to-low edge is needed to latch the data. So the data and Control pins are connected for P0.30, P0.31 & P1.16-P1.22.
- For Robot to move using DC Motor which will drive by motor driver IC here four operational pin are connect to ARM 7 P1.23-P1.26 of L293D IC and output pins are connected to M1 and M2 Respectively.

## CONCLUSION

This paper presents an automatic method for detecting railway surface defects called "squats" using IR measurements on trains. The method is based on a series of research results from our group in the field of railway engineering that includes numerical simulations. We enhance the IR signal by identifying the voltage variations, using improved IR modules interfaced to the microcontroller for making measurements. The automatic detection algorithm for squats is based on the voltage variations from the IR receiver and determines the squat locations by using GPS. The methodology is also sensitive to small rail surface defects and enables the detection of squats at their earliest stage. The hit rate for small rail surface defects was 78%.

## REFERENCES:

- [1] Z. Li, R. Dollevoet, M. Molodova, and X. Zhao, "Squat growth—some observations and the validation of numerical predictions," *Wear*, vol. 271, no. 1, pp. 148–157, May 2011.
- [2] *UIC Code, Rail Defects, 4th ed.*, International Union of Railways, Paris, France, 2002.
- [3] J. Smulders, "Management and research tackle rolling contact fatigue," *Railway Gazette Int.* 158, no. 7, pp. 439–442, Jul. 2003.

- [4] P. Clayton and M. Allery, "Metallurgical aspects of surface damage problems in rails," *Can. Metall. Q.*, vol. 21, no. 1, pp. 31–46, Jan. 1982.
- [5] Rail Damages, the Blue Book of Rail Track, U.K., 2001.
- [6] A. Zoeteman, "Life cycle cost analysis for managing rail infrastructure: Concept of a decision support system for railway design and maintenance," *Eur. J. Transport Infrastructure. Res.*, vol. 1, no. 4, pp. 391–413, 2001.

IJERGS